



# SNS COLLEGE OF TECHNOLOGY



Coimbatore-35  
An Autonomous Institution

## DEPARTMENT OF ECE

### MICROWAVE & OPTICAL ENGINEERING

III YEAR/ VI SEMESTER

#### UNIT 5 - OPTICAL NETWORKS

#### **SONET/SDH**



# Contents



- Introduction
- SONET SYSTEM
- SONET FRAME
- SONET LAYERs
- SONET Network
- Advantage



# SONET



- Synchronous optical network is a standard for optical telecommunication transport.
- We use it when we send data by optical fiber.

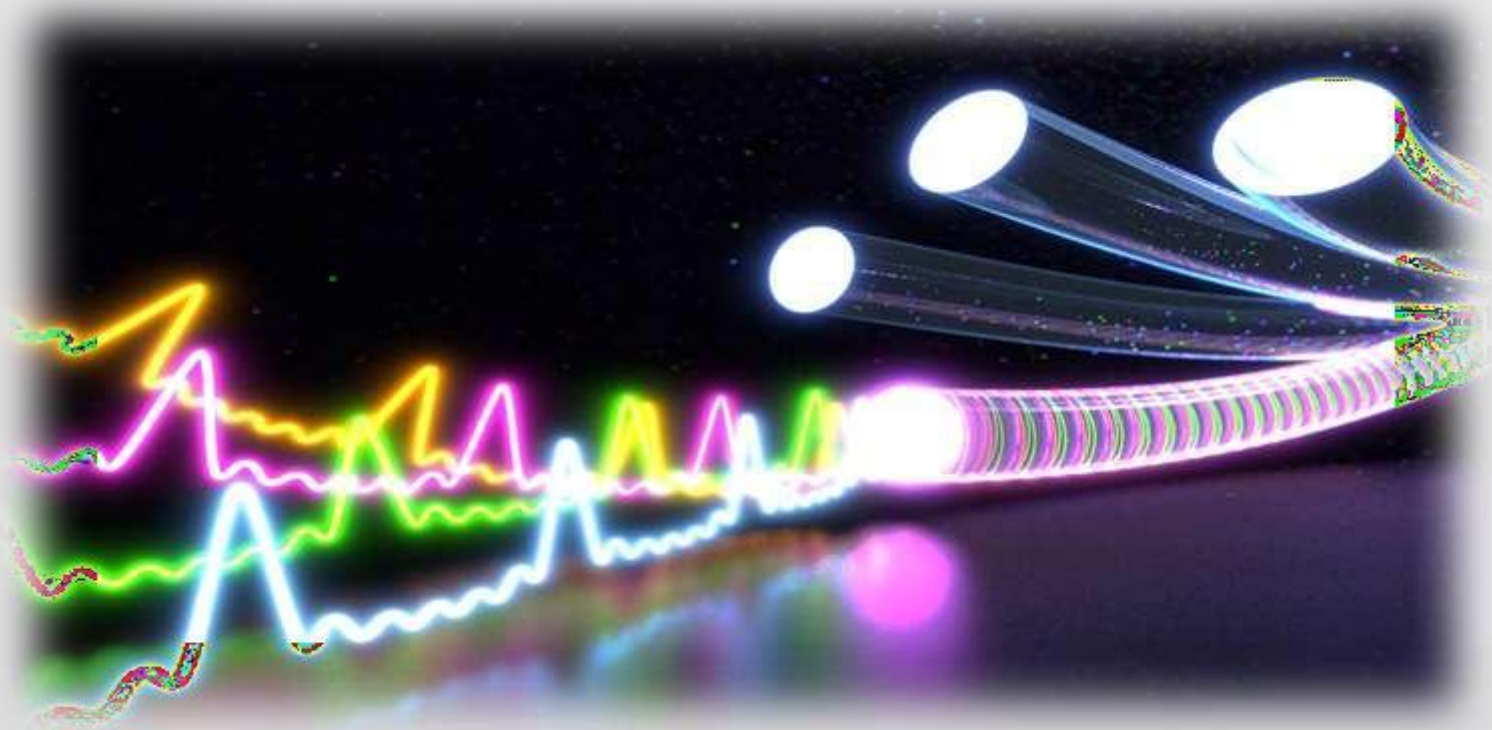



# SONET

## **Independently developed in USA & Europe:**

- SONET (Synchronous Optical Network) by ANSI.
- SDH (Synchronous Digital Hierarchy) by ITU-T.



# SONET SYSTEM



**Signals**

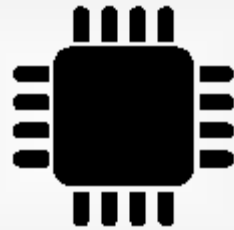

**Devices**



**Connections**



# SONET SYSTEM

## Signals:

- Electrical signaling levels called synchronous transport signals (STSs).
- The corresponding optical signals are called optical carriers (OCs).
- SDH specifies a similar system called a synchronous transport module (STM).



# SONET SYSTEM

<b>Optical carrier (OC) signal</b>	<b>Electrical signal, or synchronous transport signal (STS)</b>	<b>International Telecommunications Union (ITU) terminology</b>	<b>Bandwidth in Megabits per second (Mbps)</b>
OC-1	STS-1		51.84
OC-3	STS-3	STM-1	155.52
OC-9	STS-9	STM-3	466.56
OC-12	STS-12	STM-4	622.08
OC-18	STS-18	STM-6	933.12
OC-24	STS-24	STM-8	1244.16
OC-36	STS-36	STM-12	1866.24
OC-48	STS-48	STM-16	2488.32



# SONET SYSTEM

## Devices:

- STS multiplexers
- STS DE multiplexers
- Regenerators
- add/drop multiplexers
- Terminals.





# SONET SYSTEM

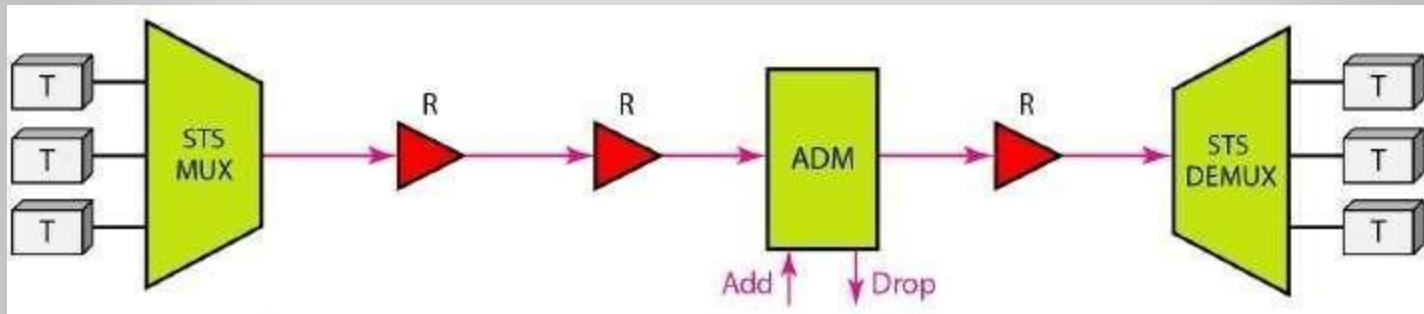



# SONET SYSTEM

## STS Multiplexer/ DE multiplexer:

- Provide the interface between an electrical tributary network and the optical network.
- STS multiplexer multiplexes an electrical signal into corresponding Optical signal.
- STS DE multiplexer DE multiplexes an optical OC signal into corresponding electric signals.





# SONET SYSTEM

## Regenerator

- Regenerator is a repeater
- Extend the length of the links

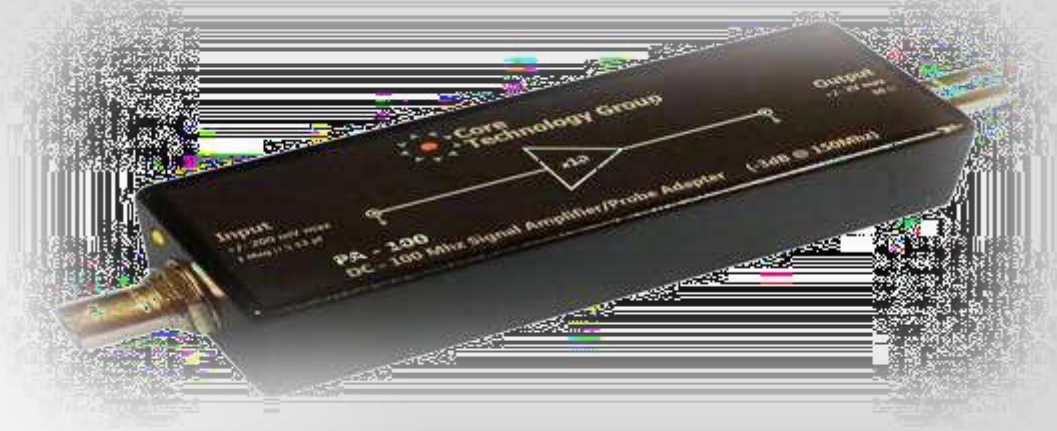



# SONET SYSTEM

## Add/drop Multiplexer

- Add/drop multiplexers allow insertion and extraction of signals.

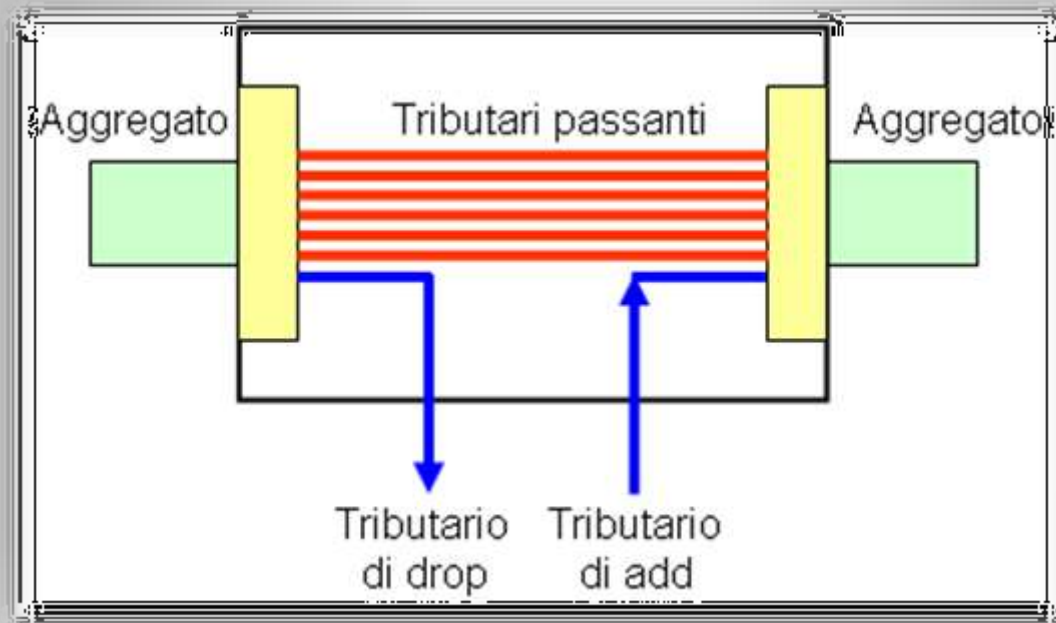



# SONET SYSTEM

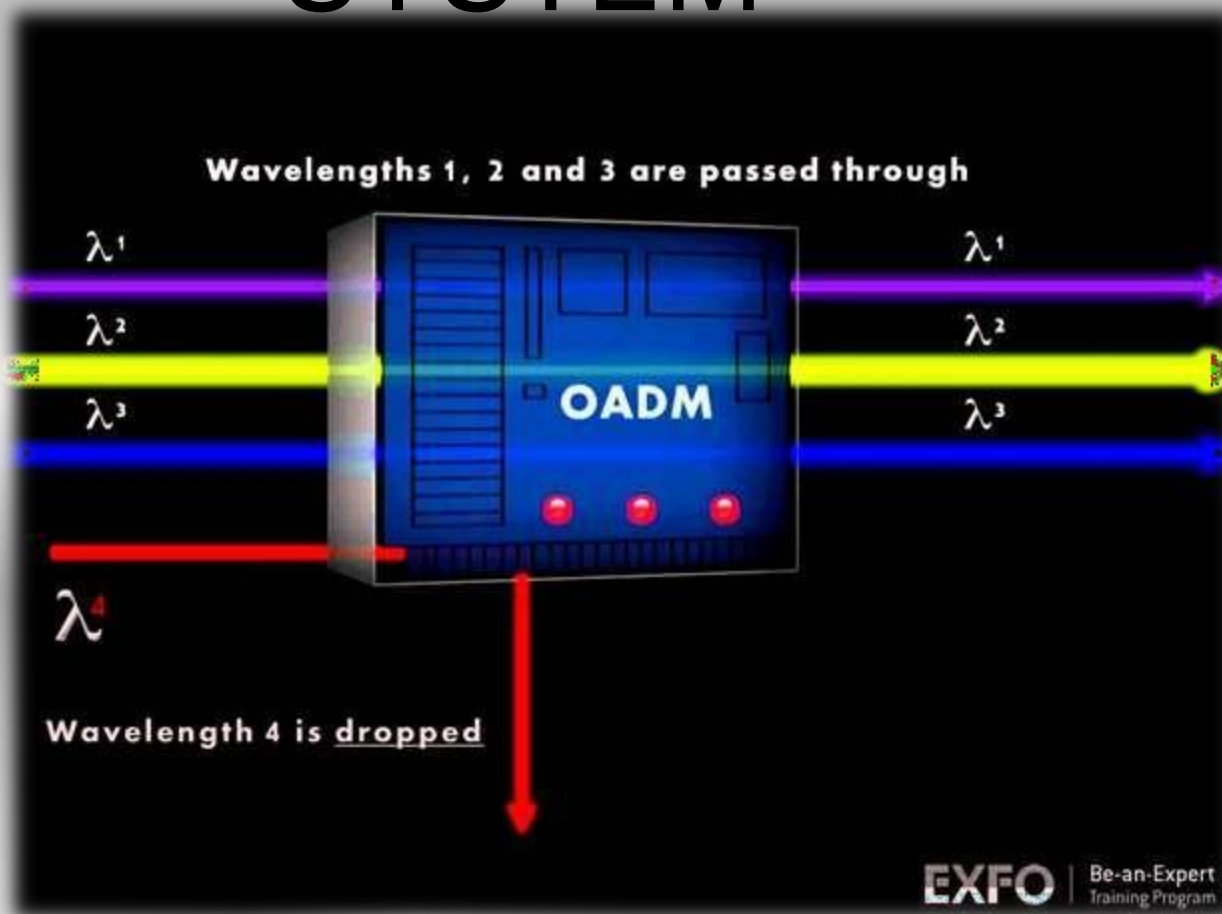



# SONET SYSTEM

## Terminals

- Device that uses the services of a SONET network.





# SONET SYSTEM

## Connections:

- Sections(connecting two neighboring devices).
- Lines(two multiplexers).
- Paths(end-to-end portion ).

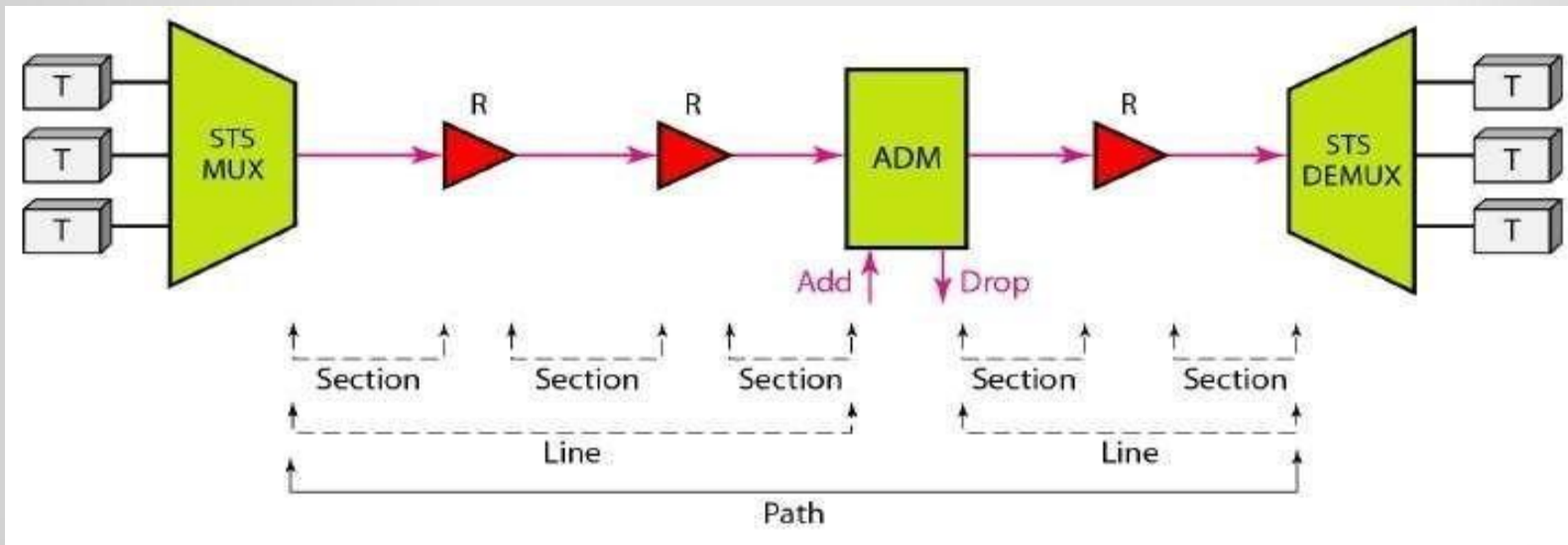



# SONET LAYERS

The SONET standard includes four functional layers:

- Path
- Line
- Section
- Photonic.

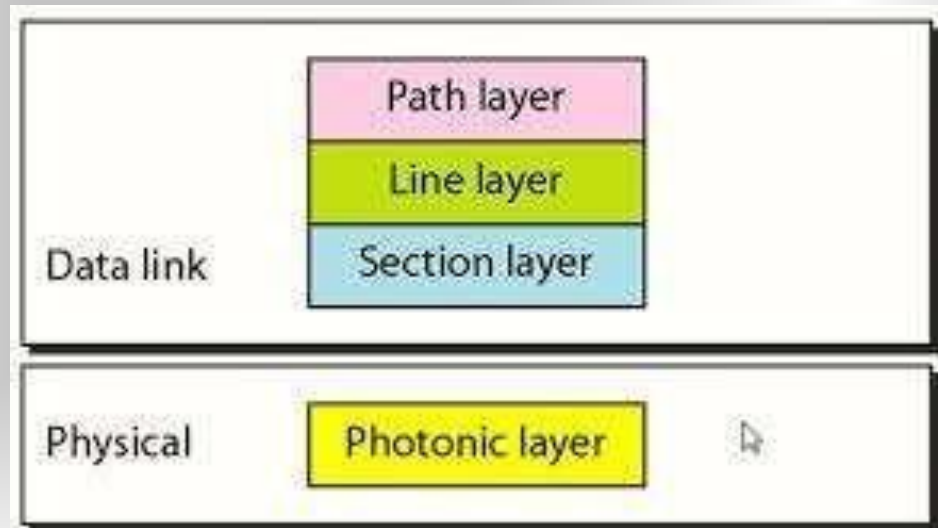





# SONET LAYERS

Path:

- The path layer is responsible for the movement of a signal from its optical source to its optical destination.

Line:

- The line layer is responsible for the movement of a signal across a physical line
- STS multiplexers and add/drop multiplexers provide line layer functions.



# SONET LAYERS

Section Layer:

- Section layer overhead is added to the frame at this layer and control errors.

Photonic Layer:

- It includes physical specifications for the optical fiber channel.
- NRZ encoding, with the presence of light representing 1 and the absence of light representing 0.



# SONET FRAME

- Two-dimensional matrix of bytes
- 9 rows by 90 x n columns
- Each byte in a SONET frame can carry a digitized voice channel.

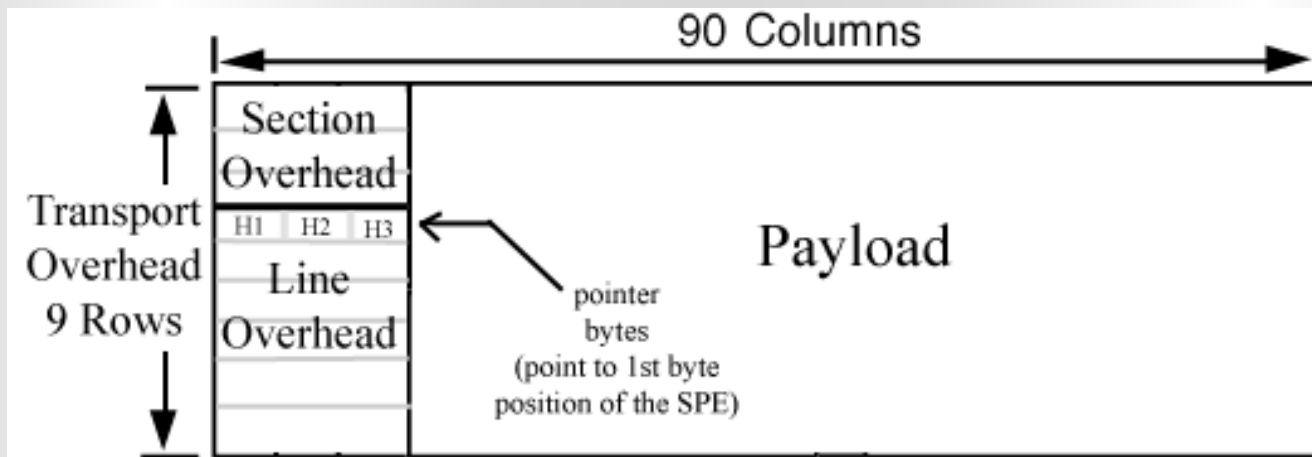



# SONET FRAME

## STS-1 Frame Structure

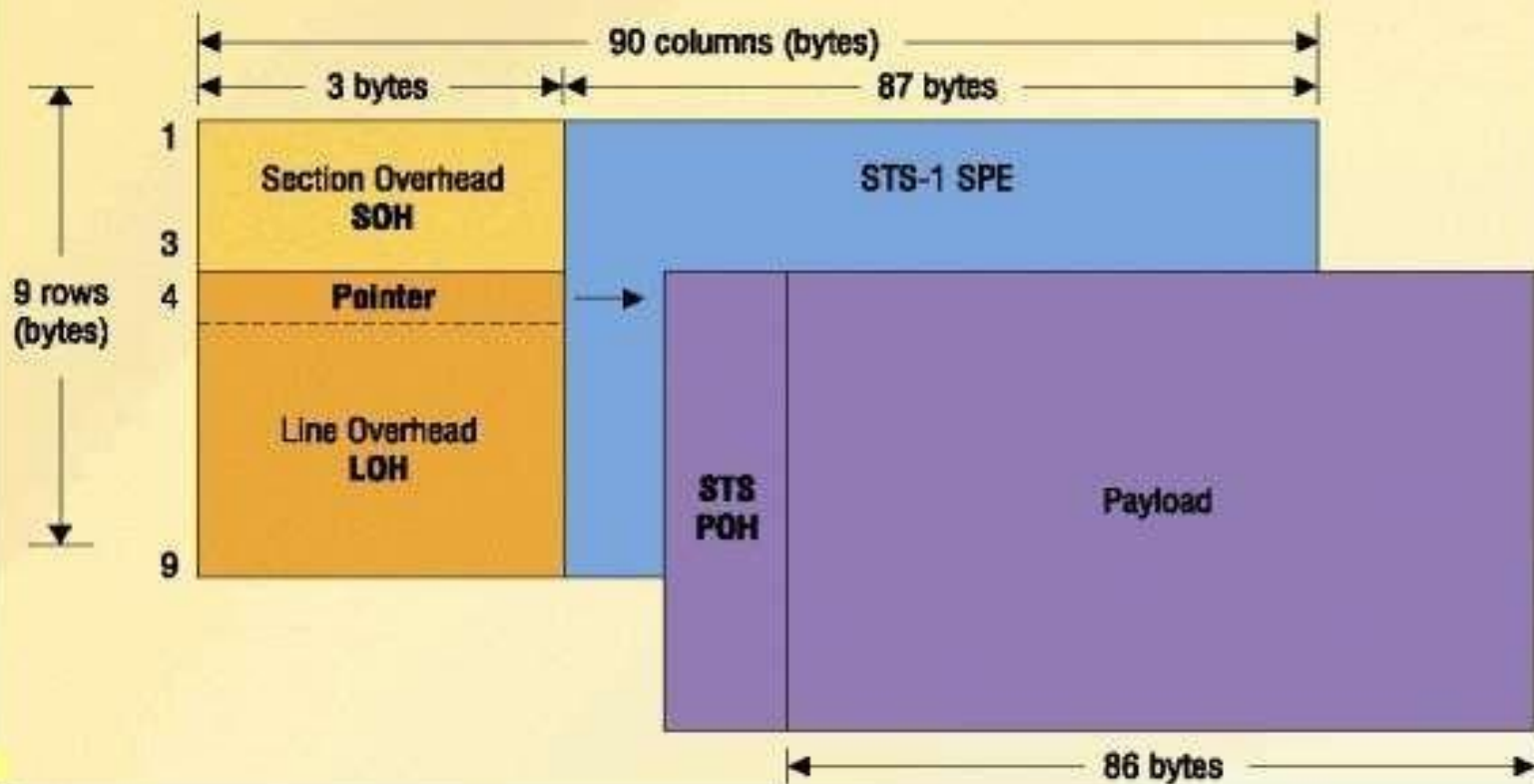



# SONET FRAME

- Bytes are transmitted from the left to the right and top to the bottom.
- STS-n signal is transmitted at a fixed rate of 8000 frames per second.

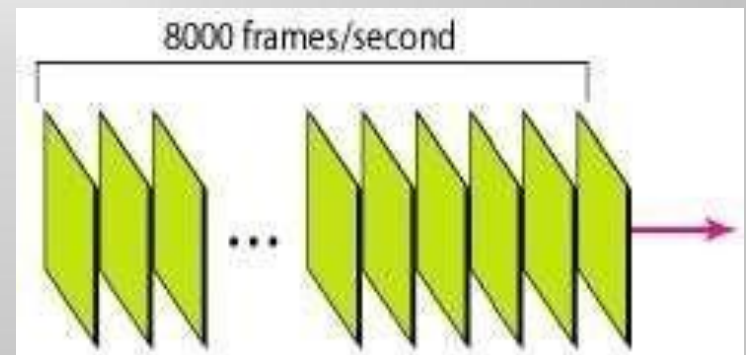
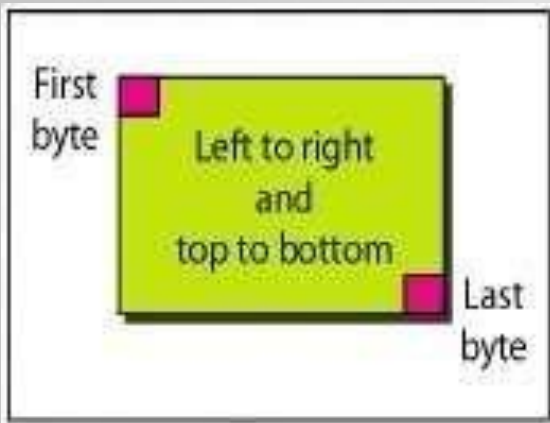



# SONET LAYERS

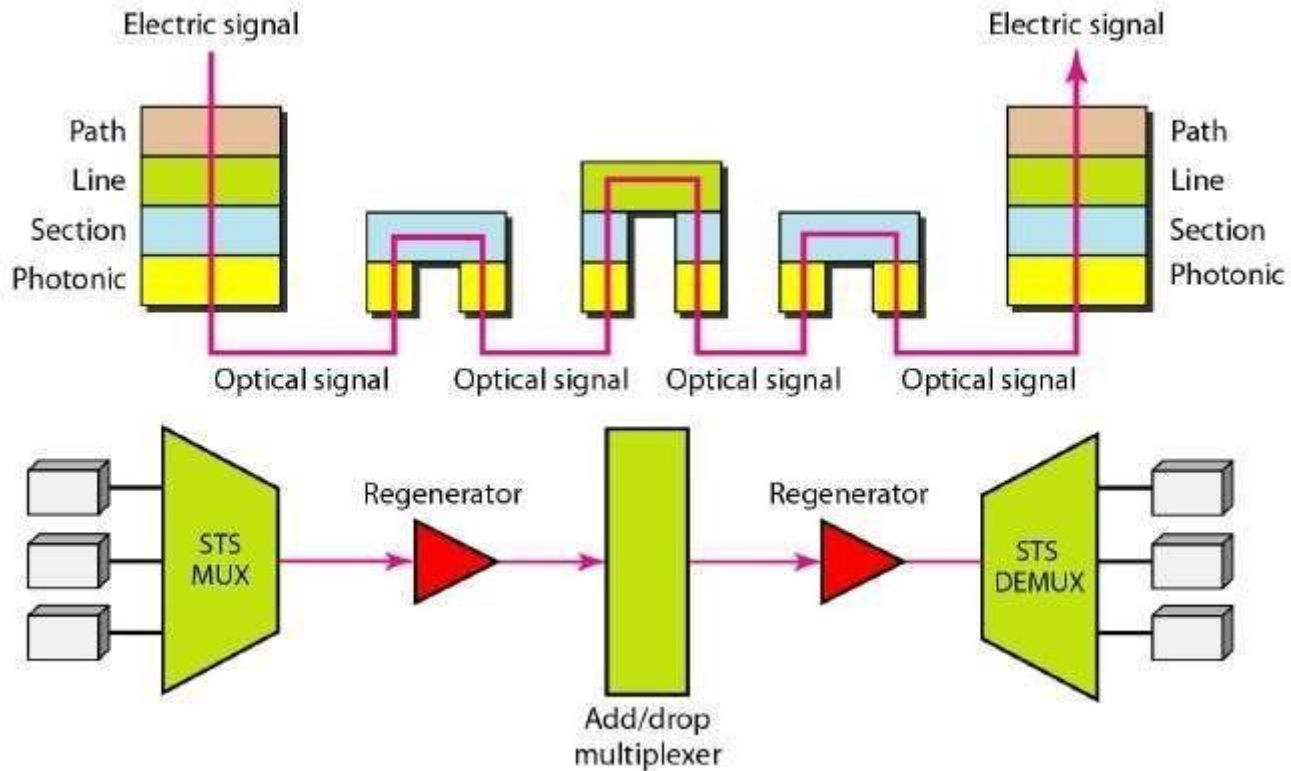



# SONET NETWORK

Using SONET equipment, we can create a SONET network that can be used as a high-speed backbone carrying loads from other networks.

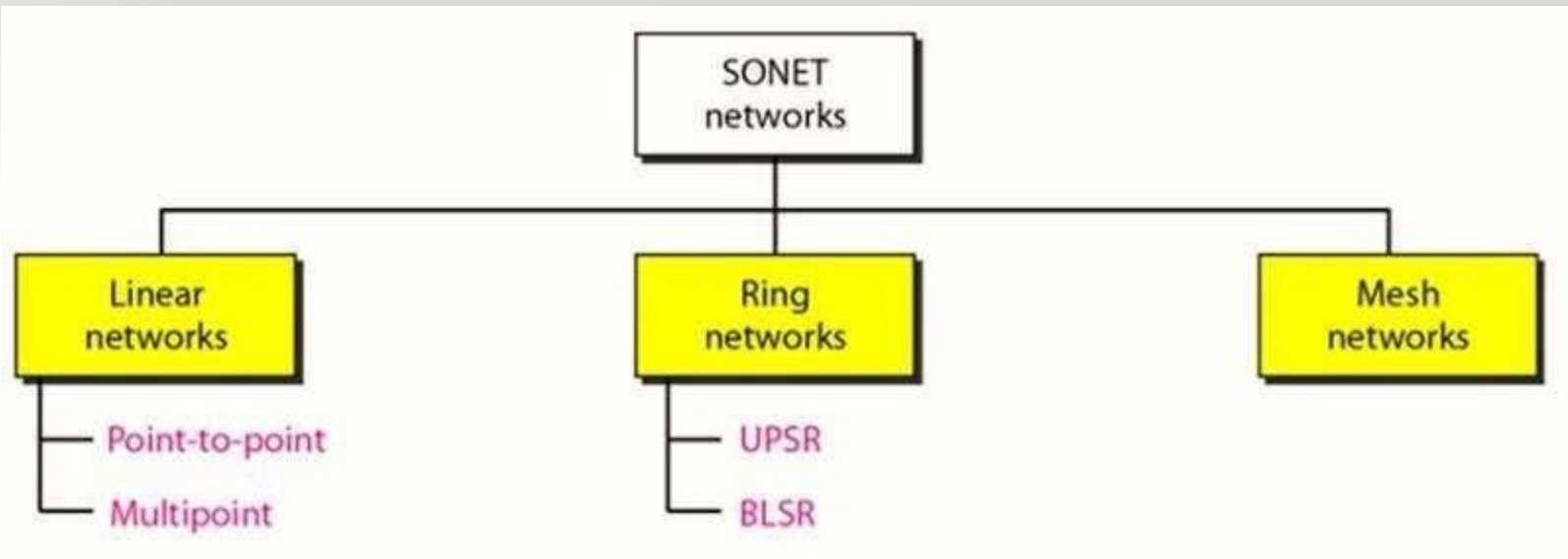



# SONET NETWORK

## Point-to-Point:

A point-to-point network is normally made of an STS multiplexer, an STS DE multiplexer, and zero or more regenerators with no add/drop

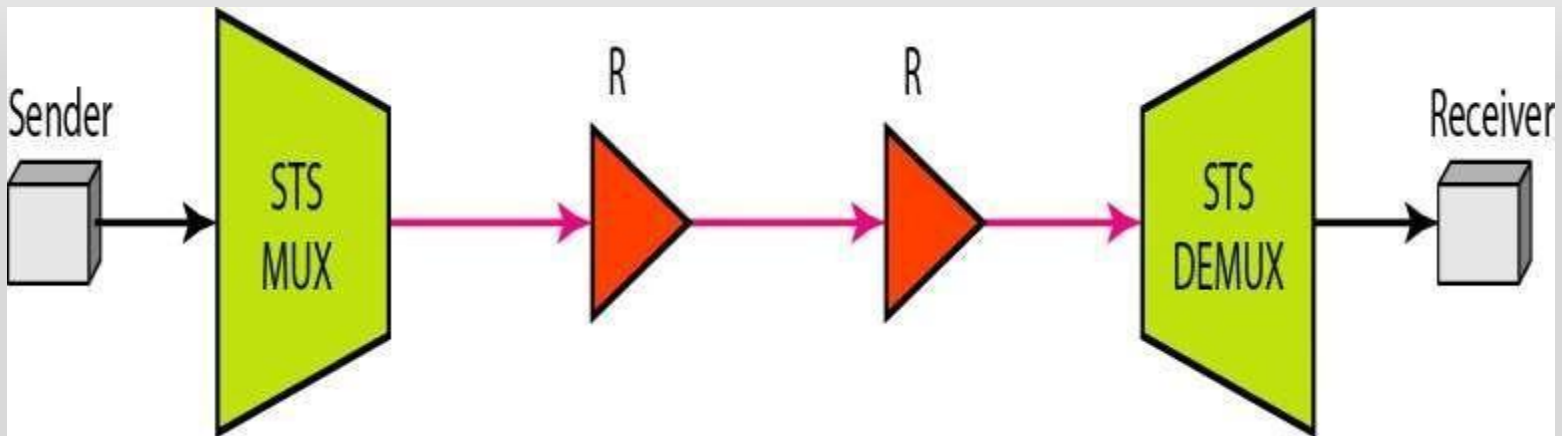





# SONET NETWORK

## Multipoint:

A multipoint network uses ADMs to allow communications between several terminals.

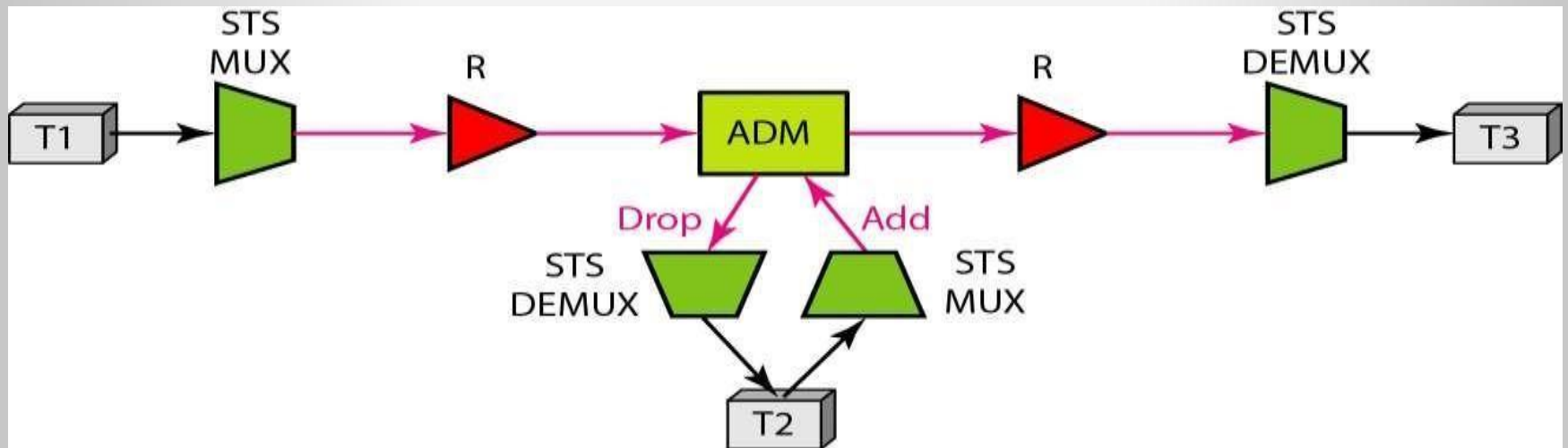



# SONET NETWORK

## One-Plus-One APS

- To create protection against failure in linear networks, SONET defines automatic protection switching (APS).
- In this scheme, there are normally two lines: one working line and one protection line. Both lines are active all the time.

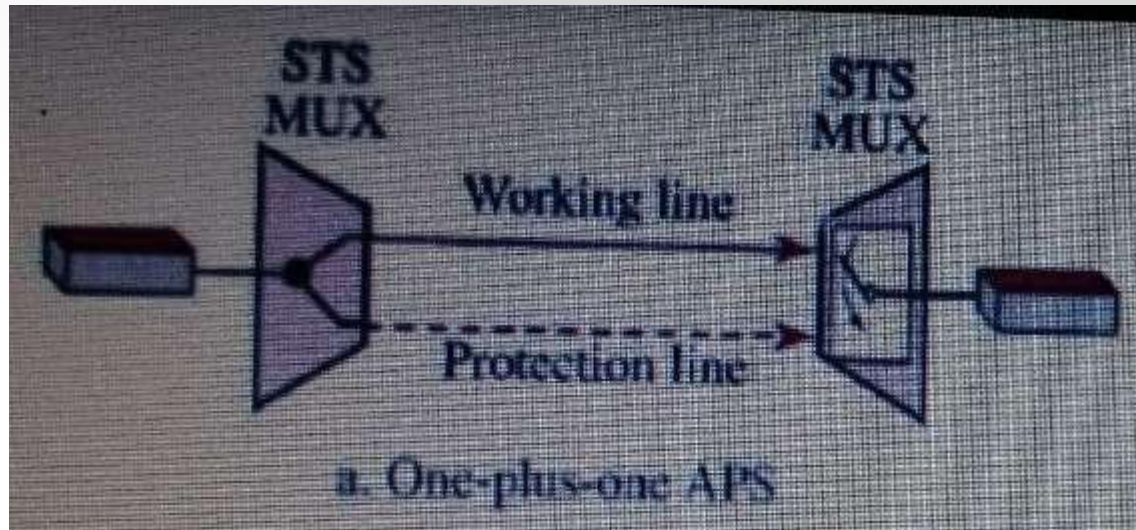



# SONET NETWORK

## One-to-One APS

- The data are normally sent on the working line until it fails.

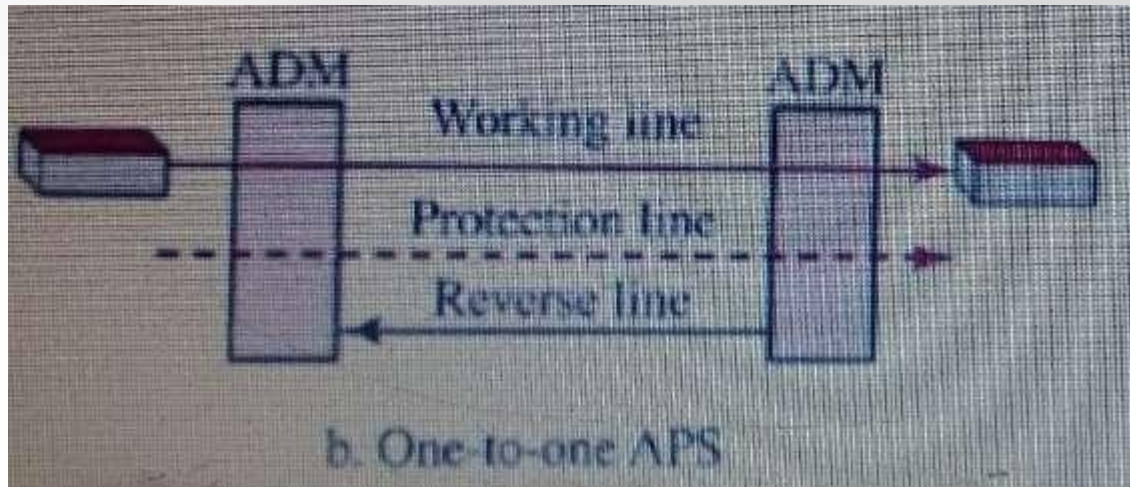



# SONET NETWORK

## One-to-Many APS

- This scheme is similar to the one-to-one scheme except that there is only one protection line for many working lines.

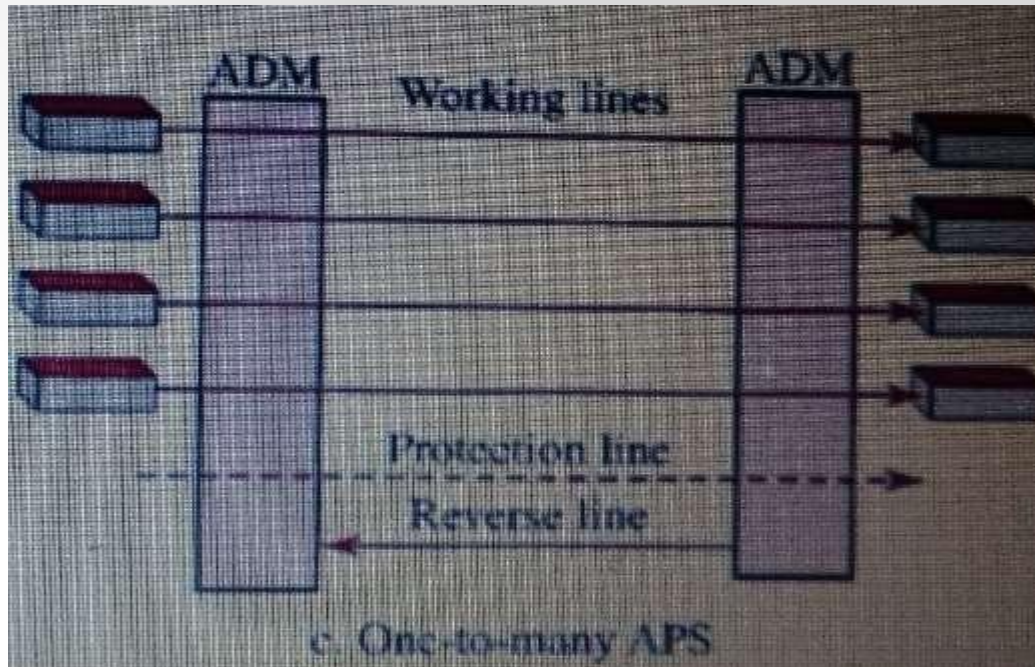



# SONET NETWORK

- Ring Network
- UPSR:
- A unidirectional path switching ring (UPSR) is a unidirectional network with

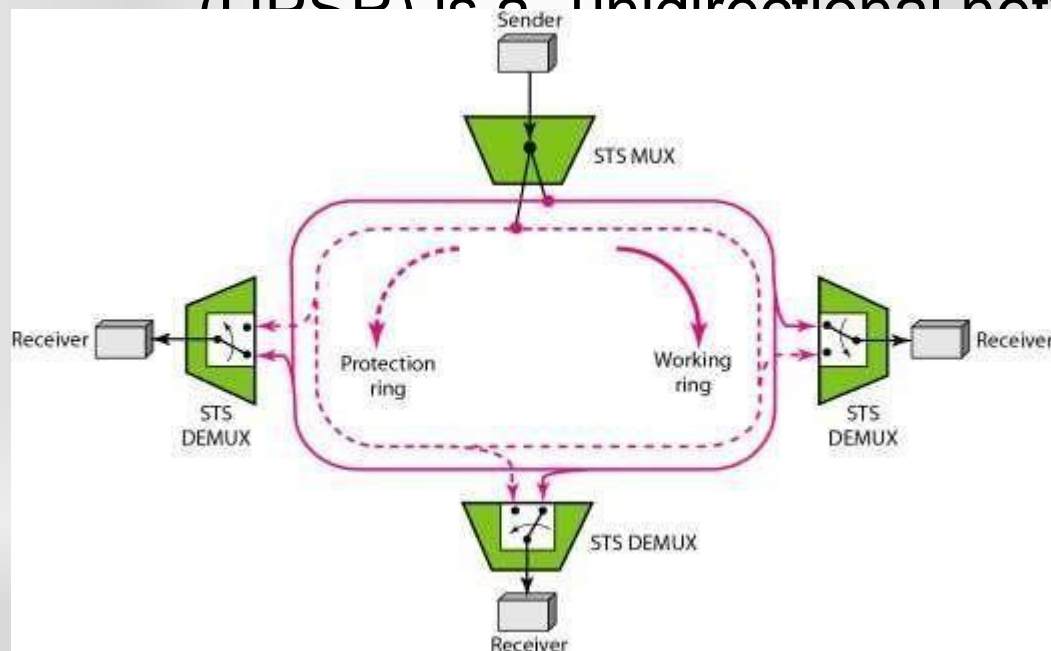



# SONET NETWORK

## BLSR:

Another alternative in a SONET ring network is a bidirectional line switching ring (BLSR).

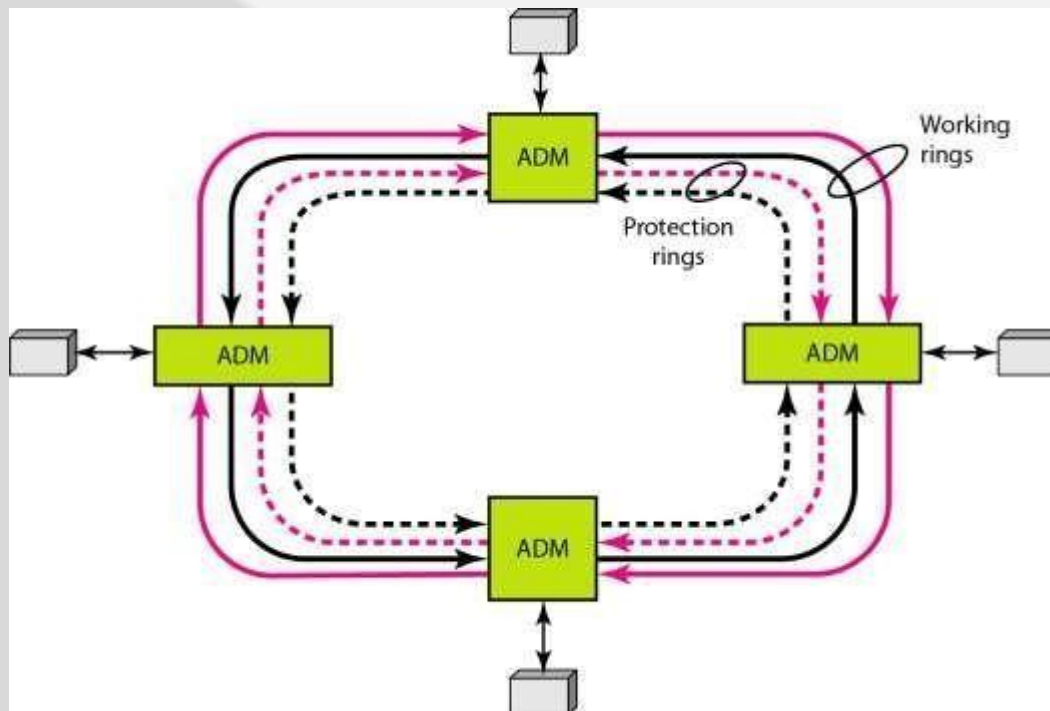



# SONET NETWORK

## Mesh Network:

When the traffic in a ring increases, we need to upgrade.

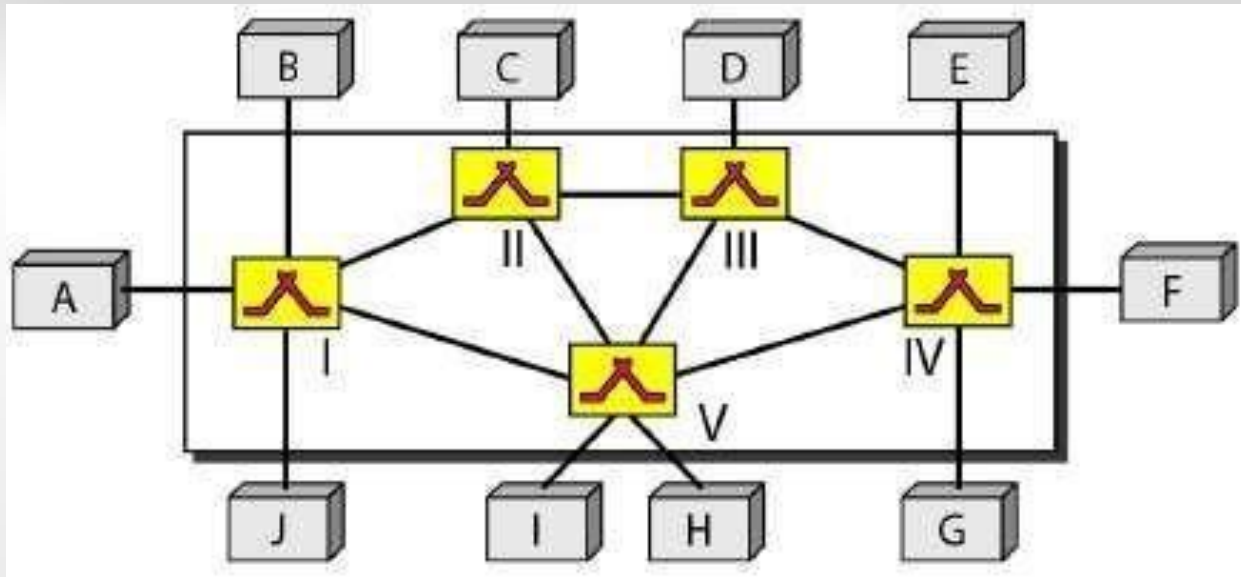



# ADVANTAGE

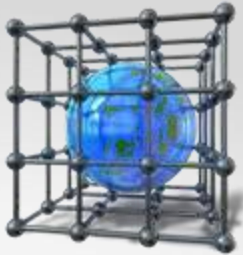

**Reduced network complexity**



**Flexible Topologies**

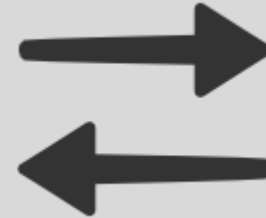

**High data rate.**



**Efficient management of bandwidth**



**Protection Bandwidth**





# SUMMARY

- Introduction
- Requirement for SONET
- In which layer SONET work
- FRAME of SONET
- SONT Network
-



# Questions

