



SNS COLLEGE OF TECHNOLOGY

(An Autonomous Institution)

COIMBATORE-35.



Accredited by NBA – AICTE and Accredited by NAAC – UGC with ‘A+’ Grade
Approved by AICTE, New Delhi & Affiliated to Anna University, Chennai.

DEPARTMENT OF AUTOMOBILE ENGINEERING

COURSE NAME : 19AU0302 - RECENT TRENDS IN AUTOMOBILES

III YEAR / VI SEMESTER

Unit 5 – Adaptive Control Systems

Topic : Traction Control System



TRACTION



- The force available at the contact between the drive wheel tyres and road is known as '**tractive effort**'.
- The ability of the drive wheels to transmit this **effort** without slipping is known as '**traction**'
- Traction is the friction between a drive wheel and the road surface
- Traction will be less in Slippery Roads.

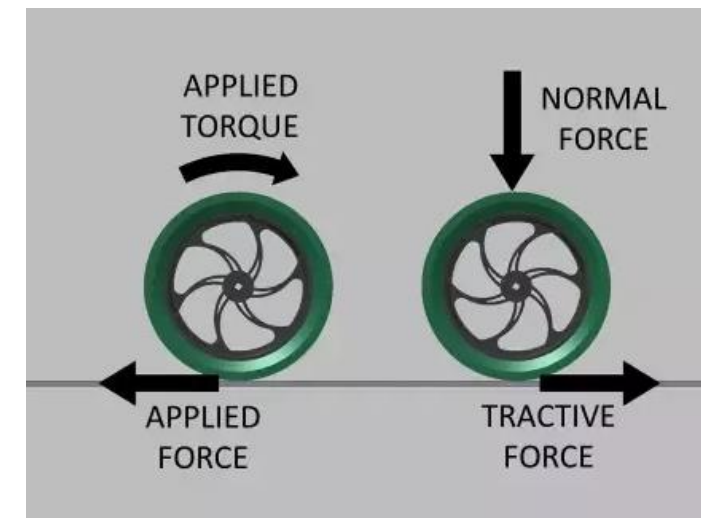



NEED FOR TRACTION CONTROL SYSTEM





INTRODUCTION TO TRACTION CONTROL SYSTEM



- **Traction control** is an active vehicle safety feature designed to help vehicles make effective use of all the **traction** available on the road when accelerating on low-friction road surfaces.

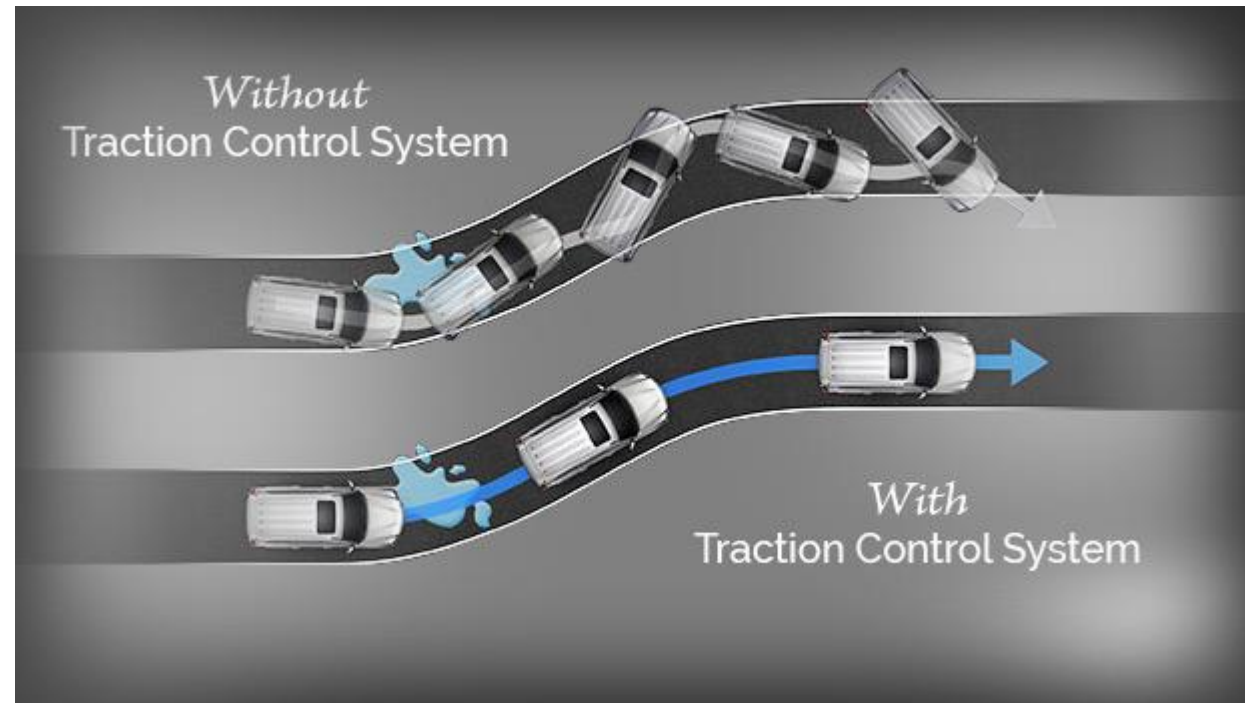



COMPONENTS



- Wheel Speed Sensors
- Traction Control Module
- Hydraulic Modulator





WORKING

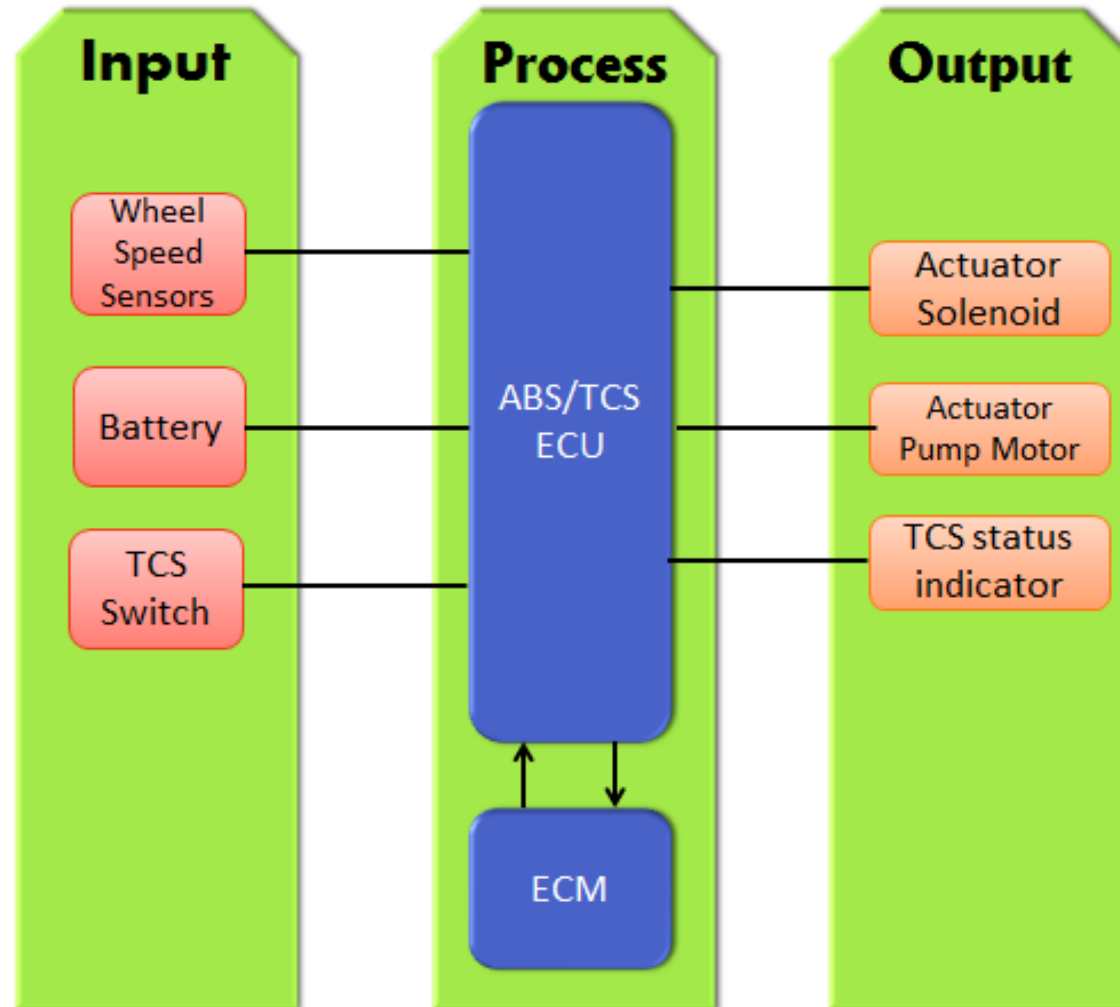



ADVANTAGES



- The installation of the traction control system is easy as it uses the same infrastructure as the ABS
- In snow and rain conditions the traction control system presents an effective control.
- When there is any problem during the rotation of the vehicle the system detects it and activates the brakes on the wheel prevents it from slipping





DISADVANTAGES



- Capital cost is high
- Requires Proper Maintenance



REFERENCE



- https://en.wikipedia.org/wiki/Traction_control_system



THANK YOU !!!