

Differential aeration Corrosion:

It is due to electrochemical attack on the metal surface, exposed to varying concentrations of oxygen.

It occurs when one part of metal is exposed to a different air concentration from the other part. It has been found experimentally that less-oxygenated parts are anodic and more oxygenated parts are Cathodic.

Explanation: If a metal is partially immersed in a conducting solution the metal part above the solution is more aerated and becomes cathodic. The metal part inside the solution is less aerated and thus becomes anodic and suffers corrosion.

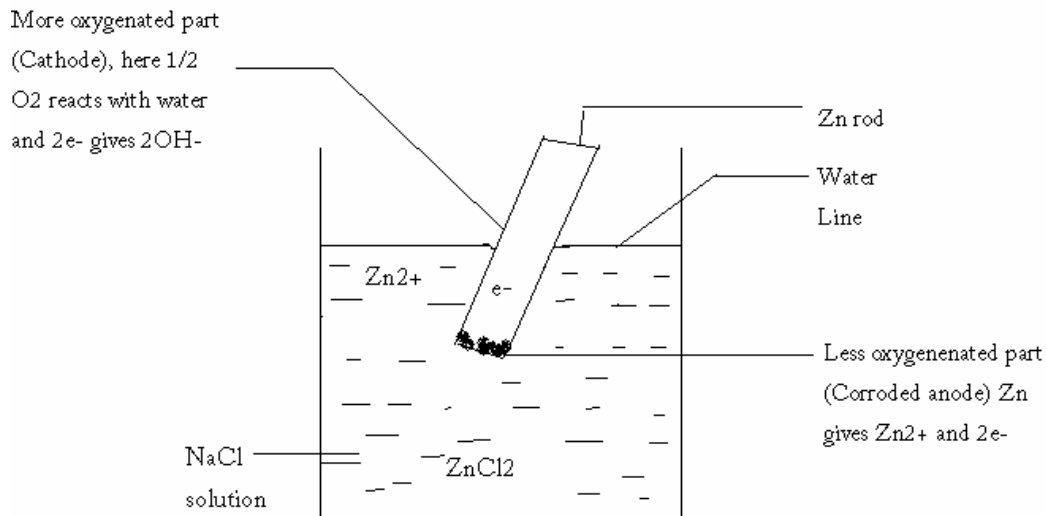

At anode: Corrosion occurs (less aerated)

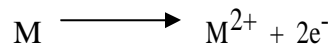

At cathode: OH⁻ ions are produced (more aerated)

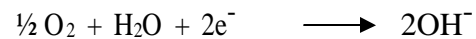

Examples for this type of corrosion are

- 1) Pitting or localized corrosion
- 2) Crevice corrosion
- 3) Pipeline corrosion
- 4) Corrosion on wire fence

Pitting Corrosion:

Pitting is a localized attack, which results in the formation of a hole around which the metal is relatively unattacked.

Metal area covered by a drop of water, dust, sand, scale etc. is the aeration or concentration Pitting corrosion is explained by considering a drop of water or brine solution (aqueous solution of NaCl) on a metal surface,).

The area covered by the drop of salt solution as less oxygen and acts as anode. This area suffers corrosion, the uncovered area acts as cathode due to high oxygen content.

It has been found that the rate of corrosion will be more when the area of cathode is larger and the area of the anode is smaller. Hence there is more material around the small anodic area results in the formation hole or pit.

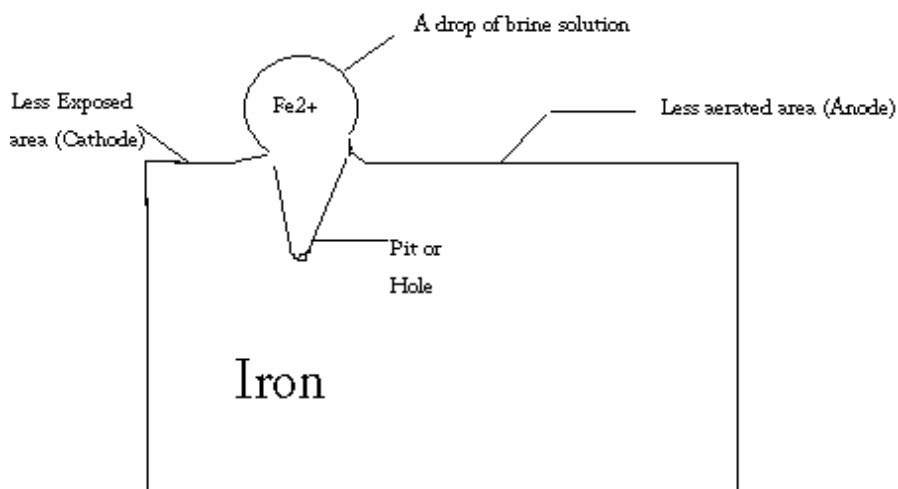

At anode: Fe is oxidized to Fe²⁺ and releases electrons.



At cathode: Oxygen is converted to hydroxide ion



The net reaction is

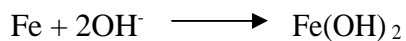

Crevice corrosion:

If a crevice (a crack forming a narrow opening) between metallic and non-metallic material is in contact with a liquid, the crevice becomes anodic region and undergoes corrosion. Hence, oxygen supply to the crevice is less. The exposed area has high oxygen supply and acts as cathode.

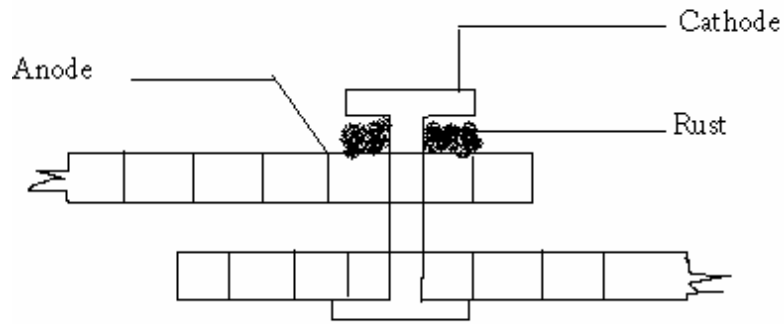

Crevice Corrosion

Bolts, nuts, rivets, joints are examples for this type of corrosion.

Pipeline corrosion:

Buried pipelines or cables passing from one type of soil (clay less aerated) to another soil (sand more aerated) may get corroded due to differential aeration.

Corrosion in wire fence:

A wire fence is one in which the areas where the wires cross (anodic) are less aerated than the rest of the fence (cathodic). Hence corrosion takes place at the wire crossing.

Corrosion occurring under metal washers and lead pipeline passing through clay to cinders (ash) are other examples.

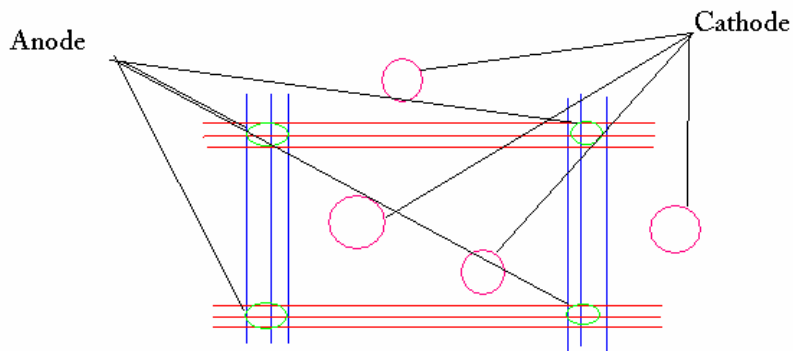

Corrosion in wire fence

