



SNS COLLEGE OF TECHNOLOGY



Coimbatore-35.

An Autonomous Institution

**Accredited by NBA – AICTE and Accredited by NAAC – UGC with ‘A+’ Grade
Approved by AICTE, New Delhi & Affiliated to Anna University, Chennai**

COURSE NAME : 19CSB201 – OPERATING SYSTEMS

II YEAR/ IV SEMESTER

UNIT – I OVERVIEW AND PROCESS MANAGEMENT

Topic: Threads : Multi-threading Models

Mr.N.Selvakumar

Assistant Professor

Department of Computer Science and Engineering



Multithreading

- Most modern applications are multithreaded
- Threads run within application
- Multiple tasks with the application can be implemented by separate threads
 - Update display
 - Fetch data
 - Spell checking
 - Answer a network request
- Process creation is heavy-weight while thread creation is light-weight
- Can simplify code, increase efficiency
- Kernels are generally multithreaded



Multithreaded Server Architecture

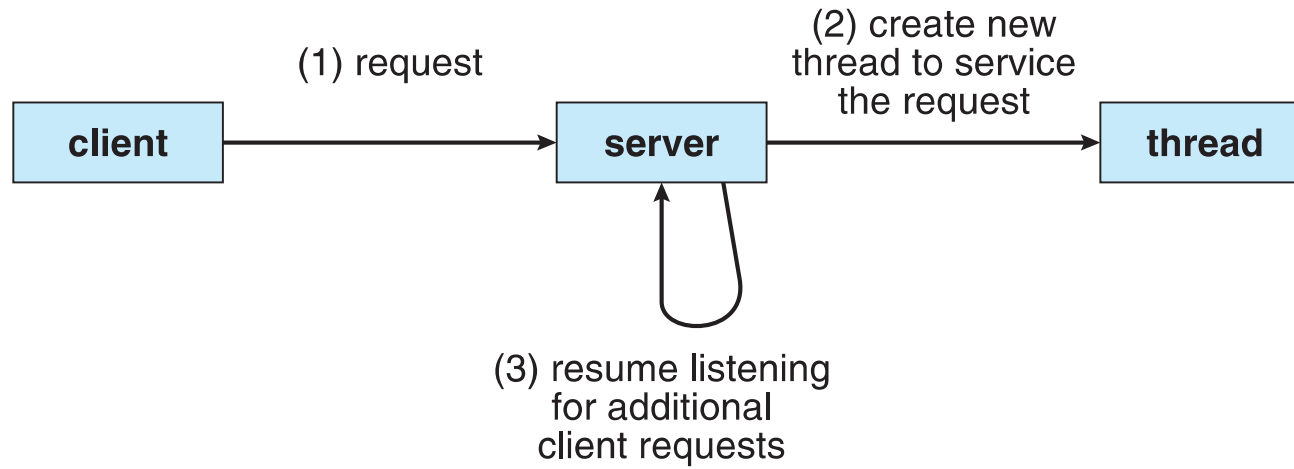



Benefits

- **Responsiveness** – may allow continued execution if part of process is blocked, especially important for user interfaces
- **Resource Sharing** – threads share resources of process, easier than shared memory or message passing
- **Economy** – cheaper than process creation, thread switching lower overhead than context switching
- **Scalability** – process can take advantage of multiprocessor architectures



Multicore Programming

- **Multicore** or **multiprocessor** systems putting pressure on programmers, challenges include:
 - **Dividing activities**
 - **Balance**
 - **Data splitting**
 - **Data dependency**
 - **Testing and debugging**
- **Parallelism** implies a system can perform more than one task simultaneously
- **Concurrency** supports more than one task making progress
 - Single processor / core, scheduler providing concurrency



- **Multicore** or **multiprocessor** systems putting pressure on programmers, challenges include:
 - **Dividing activities**
 - **Balance**
 - **Data splitting**
 - **Data dependency**
 - **Testing and debugging**
- **Parallelism** implies a system can perform more than one task simultaneously
- **Concurrency** supports more than one task making progress
 - Single processor / core, scheduler providing concurrency



Concurrency vs. Parallelism

□ Concurrent execution on single-core system:

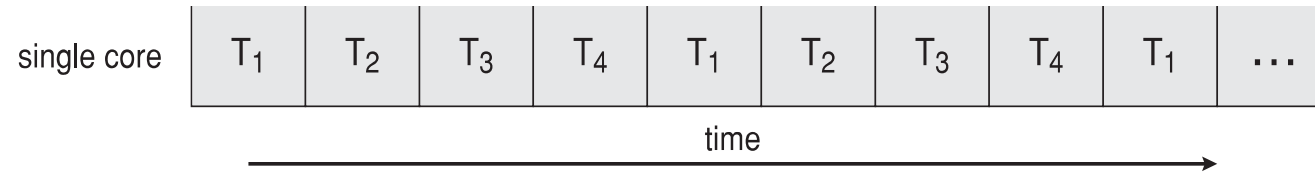

□ Parallelism on a multi-core system:

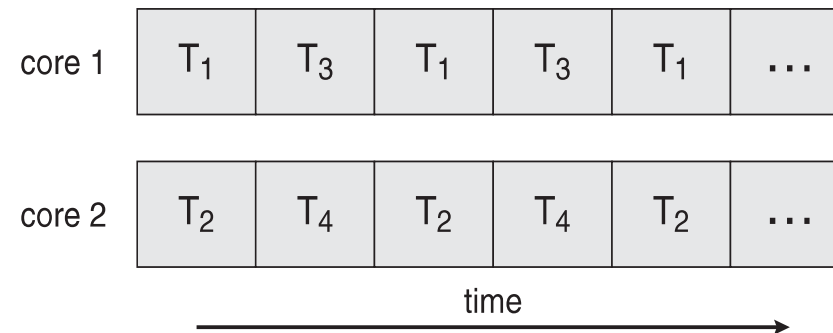



Single and Multithreaded Processes

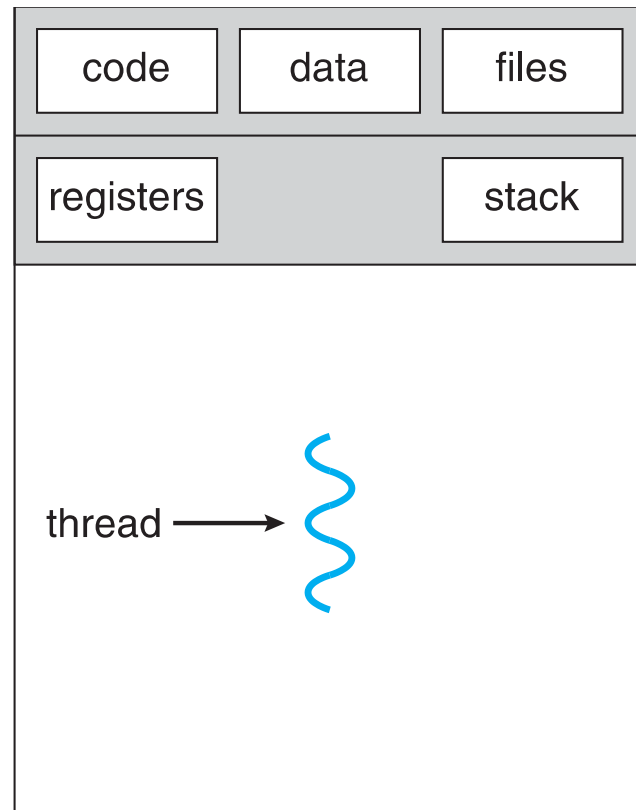

single-threaded process

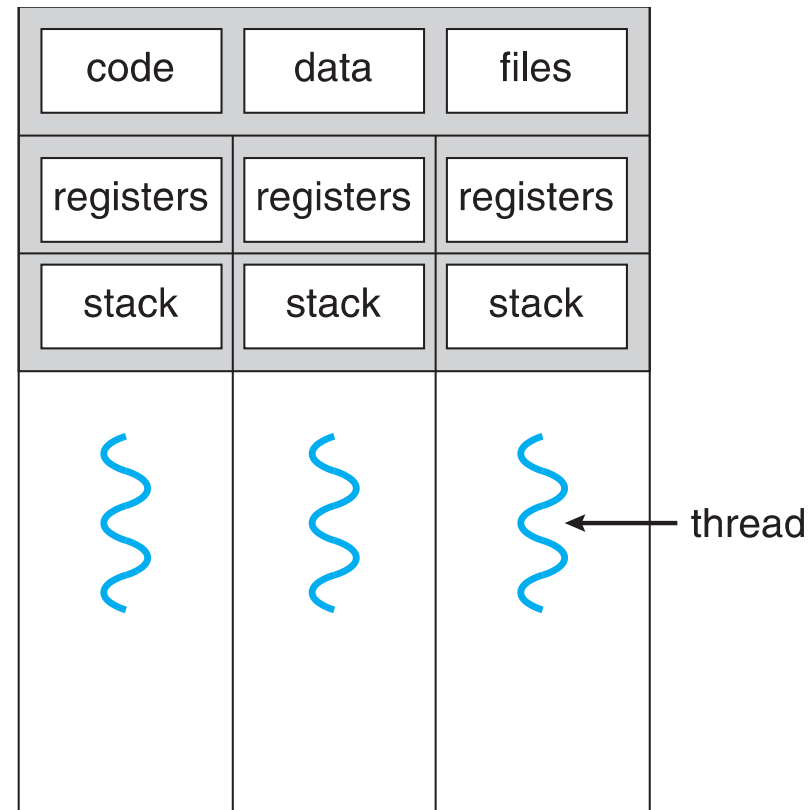

multithreaded process



User Threads and Kernel Threads

- **User threads** - management done by user-level threads library
- Three primary thread libraries:
 - POSIX **Pthreads**
 - Windows threads
 - Java threads
- **Kernel threads** - Supported by the Kernel
- Examples – virtually all general purpose operating systems, including:
 - Windows
 - Solaris
 - Linux
 - Tru64 UNIX
 - Mac OS X



Multithreading Models

- Many-to-One
- One-to-One
- Many-to-Many



Many-to-One

- Many user-level threads mapped to single kernel thread
- One thread blocking causes all to block
- Multiple threads may not run in parallel on multicore system because only one may be in kernel at a time
- Few systems currently use this model
- Examples:
 - **Solaris Green Threads**
 - **GNU Portable Threads**

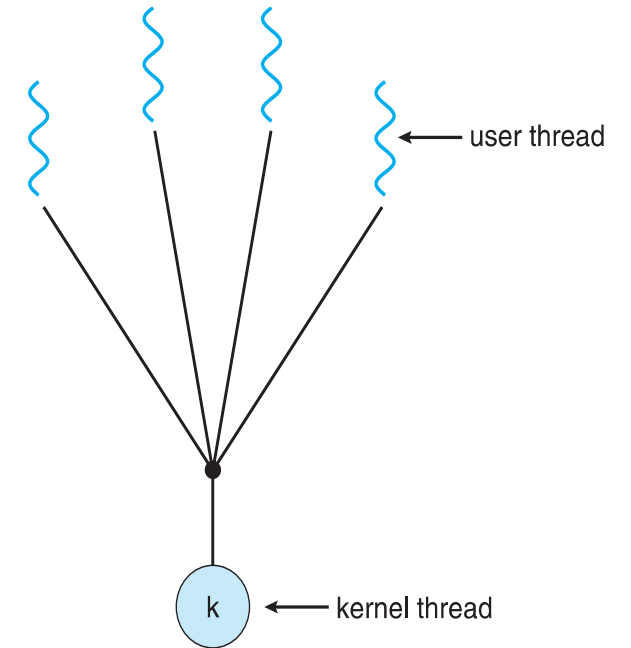



One-to-One

- Each user-level thread maps to kernel thread
- Creating a user-level thread creates a kernel thread
- More concurrency than many-to-one
- Number of threads per process sometimes restricted due to overhead
- Examples
 - Windows
 - Linux
 - Solaris 9 and later

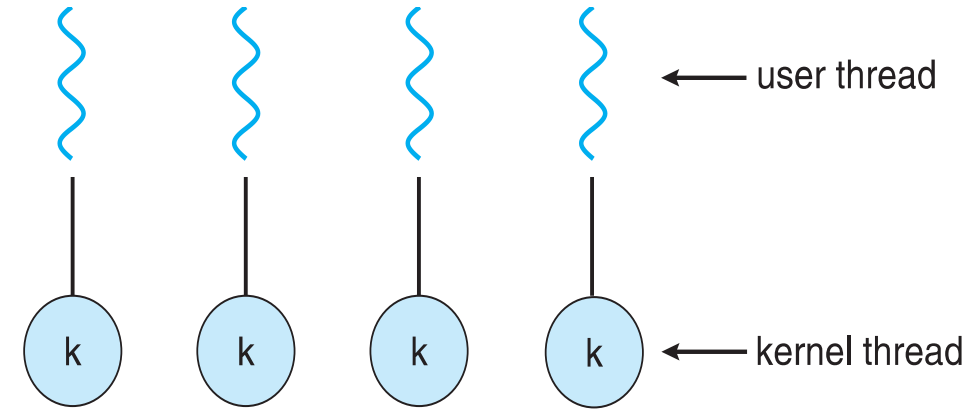



Many-to-Many Model

- Allows many user level threads to be mapped to many kernel threads
- Allows the operating system to create a sufficient number of kernel threads
- Solaris prior to version 9
- Windows with the *ThreadFiber* package

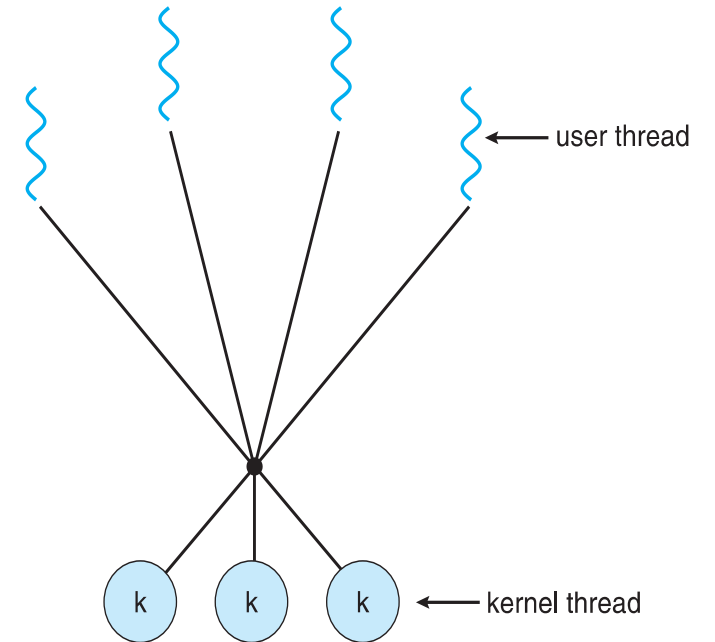



Two-level Model

- Similar to M:M, except that it allows a user thread to be **bound** to kernel thread
- Examples
 - IRIX
 - HP-UX
 - Tru64 UNIX
 - Solaris 8 and earlier

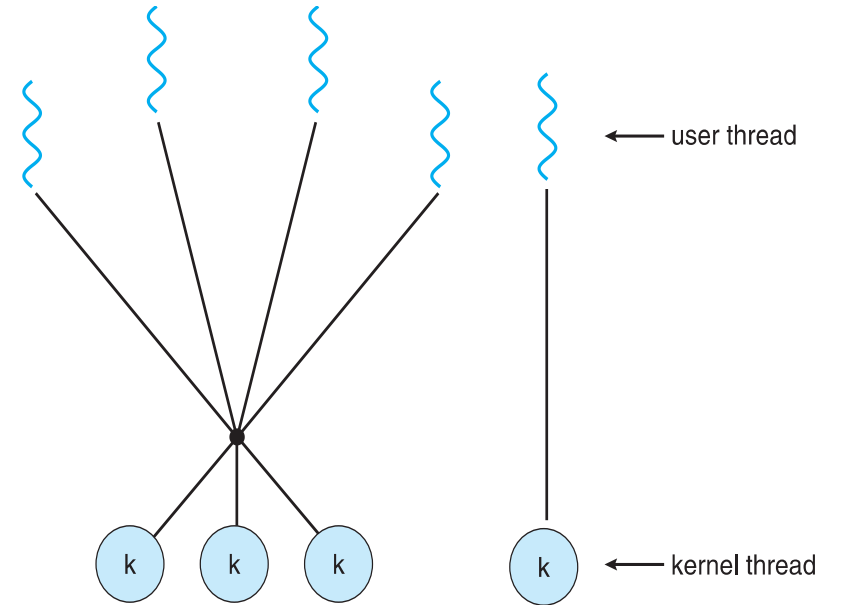



Thread Libraries

- **Thread library** provides programmer with API for creating and managing threads
- Two primary ways of implementing
 - Library entirely in user space
 - Kernel-level library supported by the OS



Pthreads

- May be provided either as user-level or kernel-level
- A POSIX standard (IEEE 1003.1c) API for thread creation and synchronization
- ***Specification***, not ***implementation***
- API specifies behavior of the thread library, implementation is up to development of the library
- Common in UNIX operating systems (Solaris, Linux, Mac OS X)



Thread Pools

- Create a number of threads in a pool where they await work
- Advantages:
 - Usually slightly faster to service a request with an existing thread than create a new thread
 - Allows the number of threads in the application(s) to be bound to the size of the pool
 - Separating task to be performed from mechanics of creating task allows different strategies for running task
 - i.e.Tasks could be scheduled to run periodically
- Windows API supports thread pools:

```
DWORD WINAPI PoolFunction(AVOID Param) {  
    /*  
    * this function runs as a separate thread.  
    */  
}
```



REFERENCES

TEXT BOOKS:

- T1 Silberschatz, Galvin, and Gagne, “Operating System Concepts”, Ninth Edition, Wiley India Pvt Ltd, 2009.)
- T2. Andrew S. Tanenbaum, “Modern Operating Systems”, Fourth Edition, Pearson Education, 2010

REFERENCES:

- R1 Gary Nutt, “Operating Systems”, Third Edition, Pearson Education, 2004.
- R2 Harvey M. Deitel, “Operating Systems”, Third Edition, Pearson Education, 2004.
- R3 Abraham Silberschatz, Peter Baer Galvin and Greg Gagne, “Operating System Concepts”, 9th Edition, John Wiley and Sons Inc., 2012.
- R4. William Stallings, “Operating Systems – Internals and Design Principles”, 7th Edition, Prentice Hall, 2011

