



SNS COLLEGE OF TECHNOLOGY

Coimbatore-35
An Autonomous Institution



Accredited by NBA – AICTE and Accredited by NAAC – UGC with 'A++' Grade
Approved by AICTE, New Delhi & Affiliated to Anna University, Chennai

DEPARTMENT OF ELECTRONICS & COMMUNICATION ENGINEERING

19ECT213-IoT SYSTEM ARCHITECTURE II YEAR/ IV SEMESTER

UNIT 2 – MICROCONTROLLER AND INTERFACING TECHNIQUES FOR IoT DEVICES

TOPIC 5 – EMBEDDED DEVICES-SENSORS & ACTUATORS



OVERVIEW

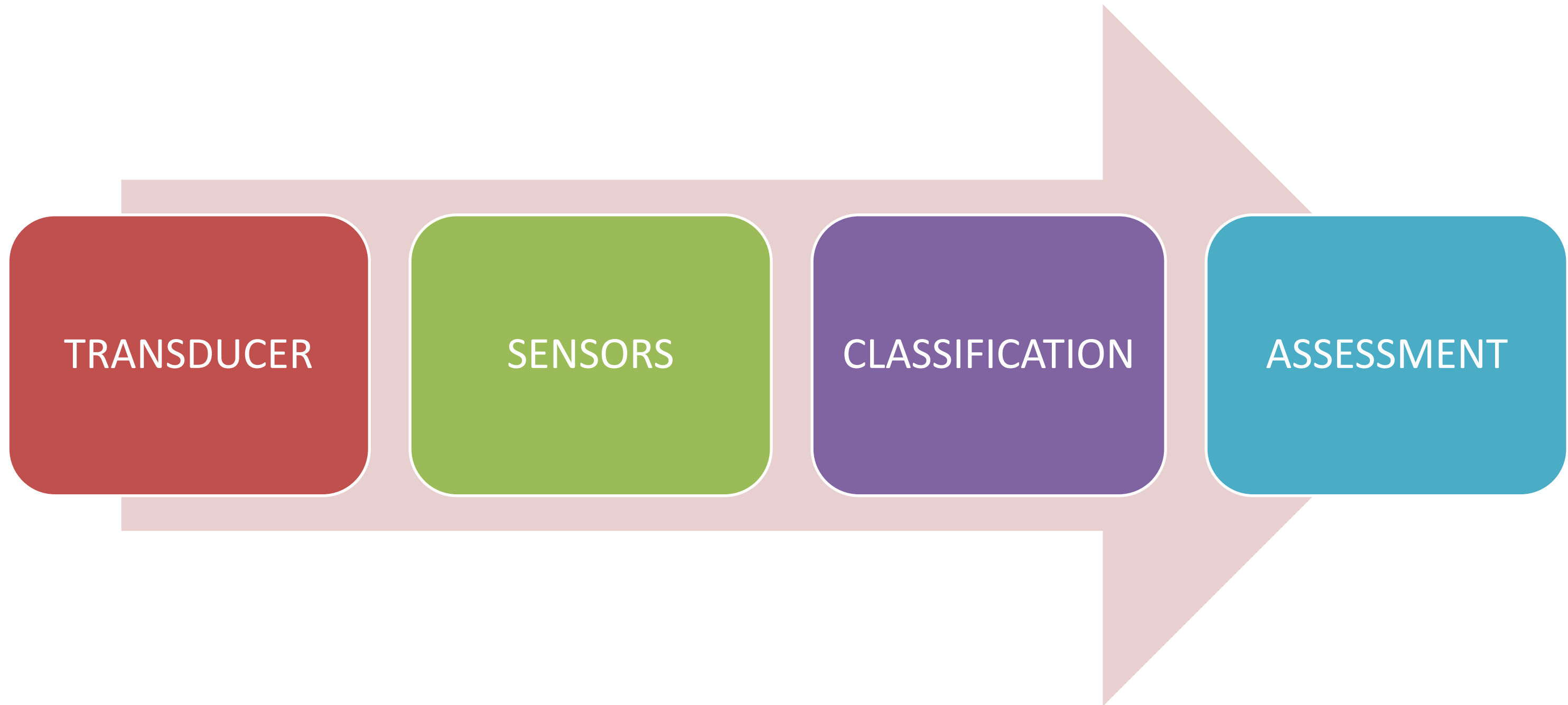



TRANSDUCER



A device that converts variations in a physical quantity, such as pressure or brightness, into an electrical signal, or vice versa.

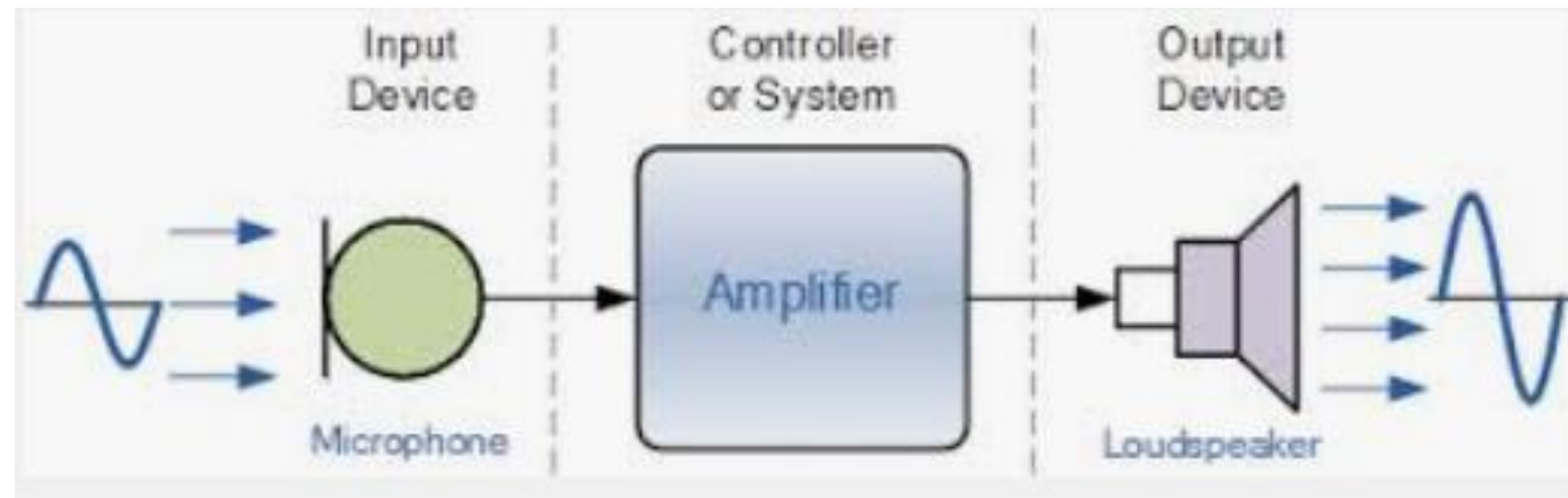



SENSORS



Sensors are sophisticated devices that are frequently used to detect and respond to electrical or optical signals. A **Sensor** converts the physical parameter (for example: temperature, blood pressure, humidity, speed, etc.) into a signal which can be measured electrically.



PROXIMITY SENSORS



TYPES OF SENSORS





TYPES OF SENSORS





CLASSIFICATION BASED ON



The transducer is of many types, and they can be classified by the following criteria.

By transduction used.

- as a primary and secondary transducer
- as a passive and active transducer
- as analog and digital transducer
- as the transducer and inverse transducer

The transducer receives the measurand and gives a proportional amount of output signal. The output signal is sent to the conditioning device where the signal is attenuated, filtered, and modulated.

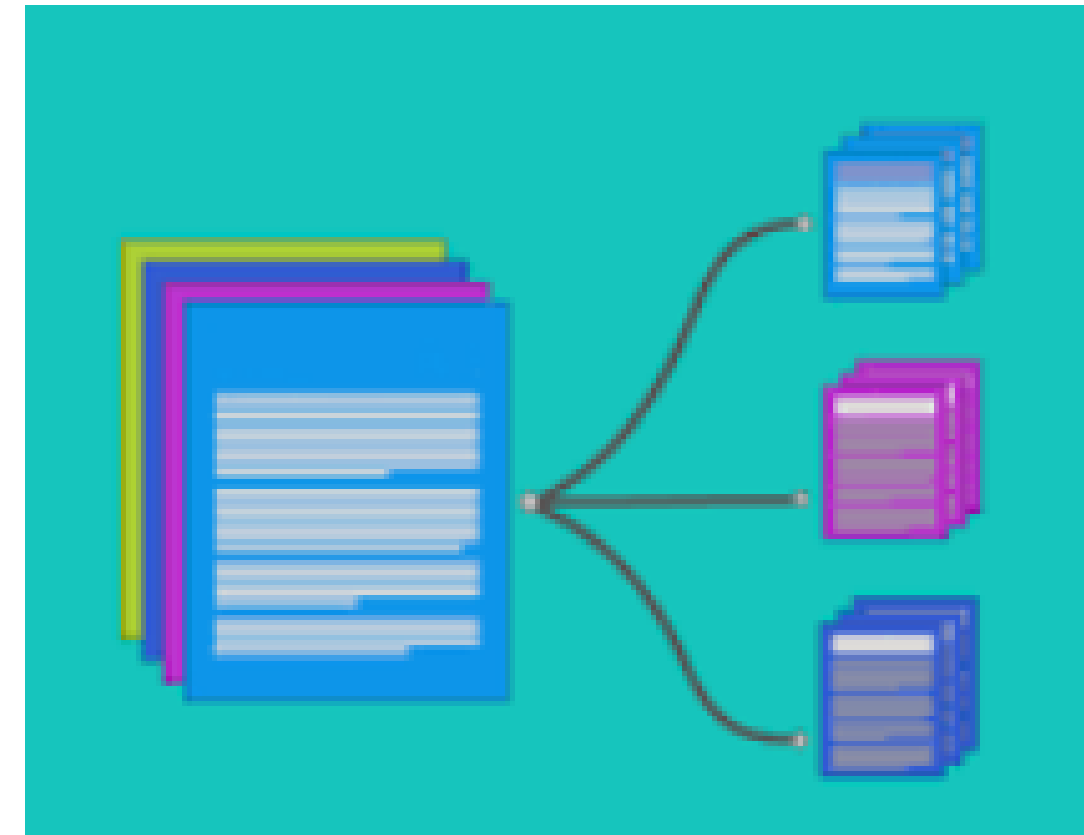



CLASSIFICATION OF TRANSDUCERS

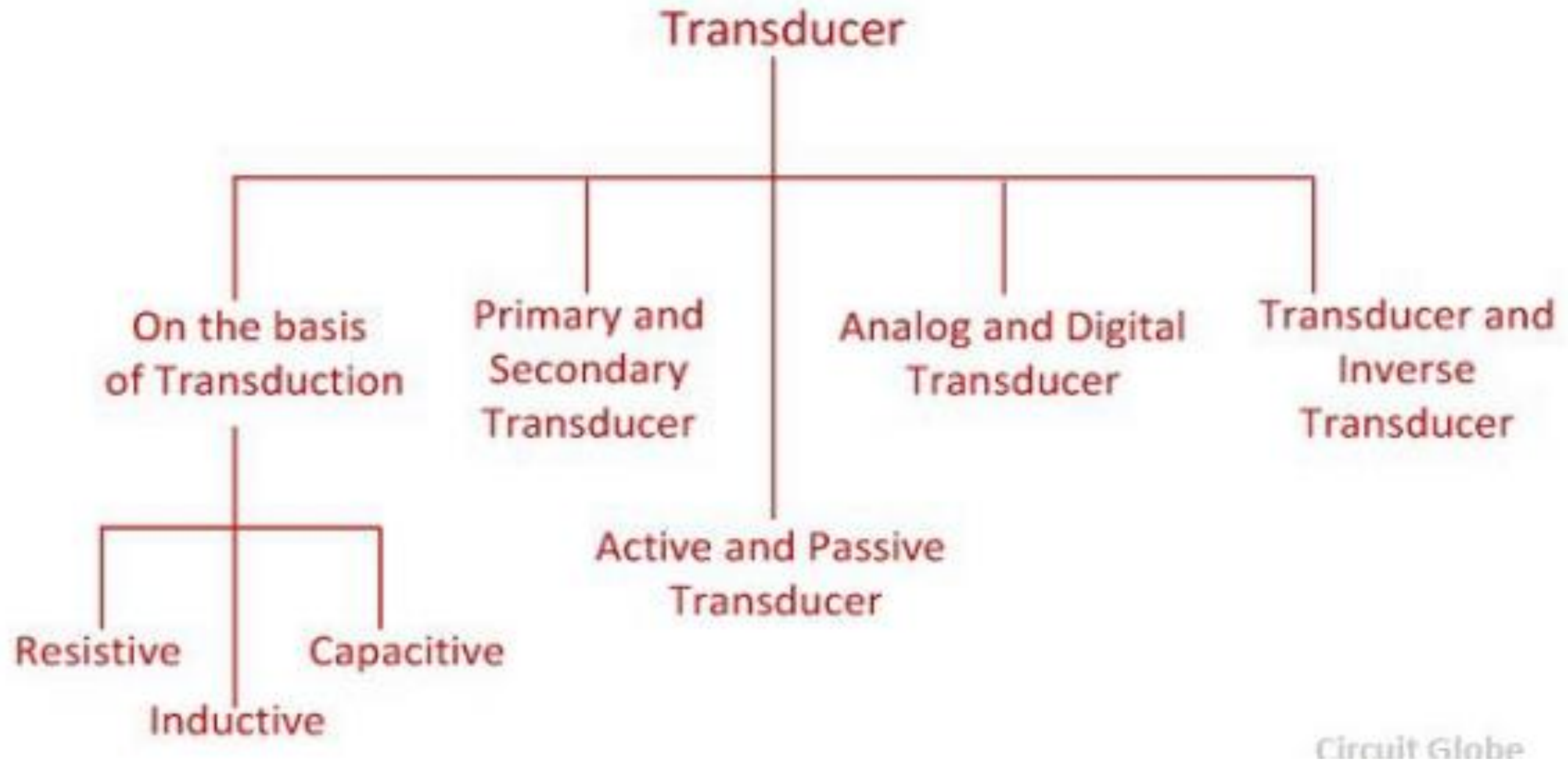



BASED ON TRANSDUCTION



The transducer is classified by the transduction medium. The transduction medium may be resistive, inductive or capacitive depends on the conversion process that how input transducer converts the input signal into resistance, inductance and capacitance respectively.



PRIMARY & SECONDARY TRANSDUCER



Primary Transducer – The transducer consists the mechanical as well as the electrical devices. The mechanical devices of the transducer change the physical input quantities into a mechanical signal. This mechanical device is known as the primary transducers.

Secondary Transducer – The secondary transducer converts the mechanical signal into an electrical signal. The magnitude of the output signal depends on the input mechanical signal.

The Bourdon's Tube is the primary transducer, and the L.V.D.T is called the secondary transducer.

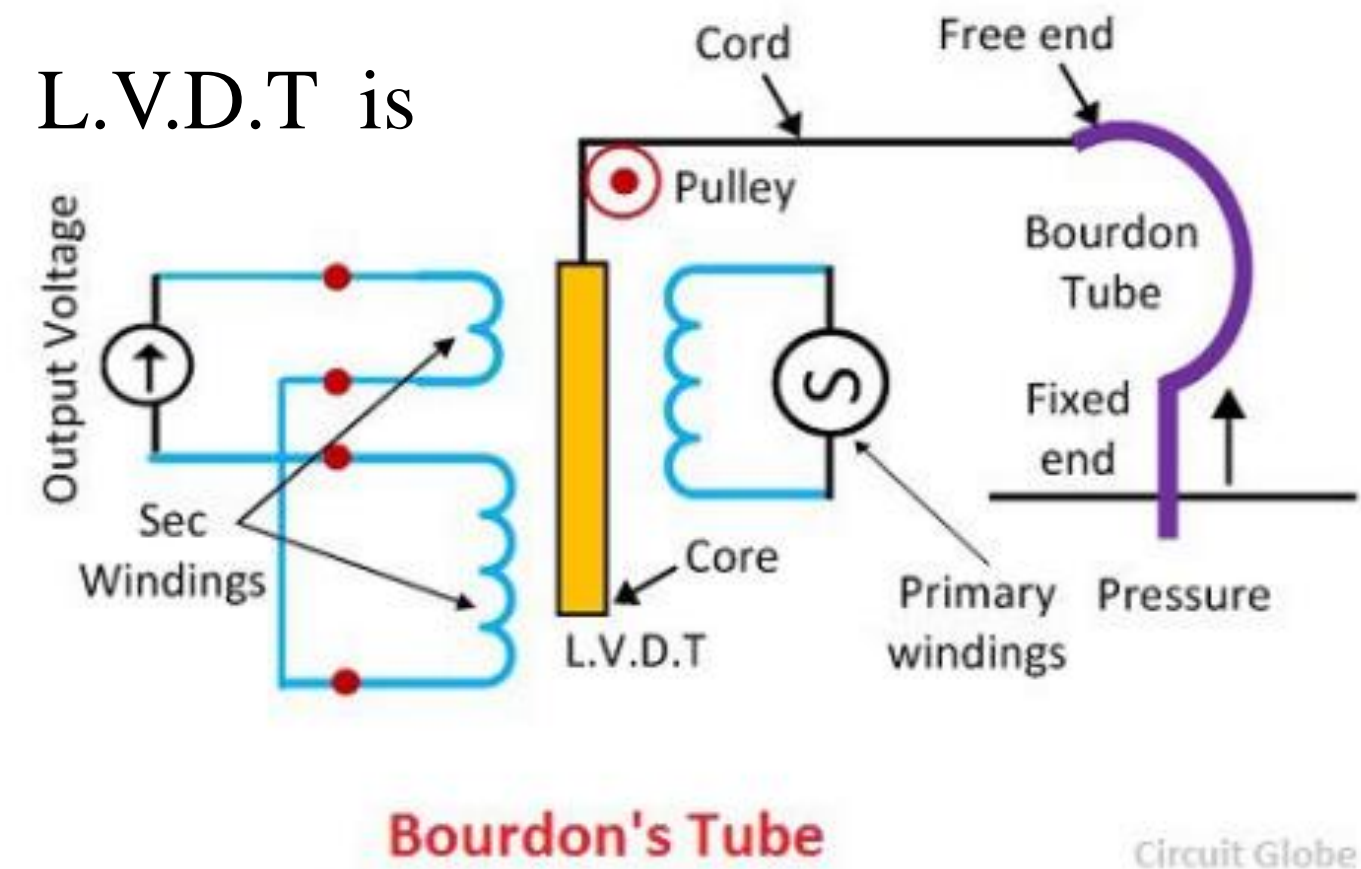



ACTIVE & PASSIVE TRANSDUCER



Active Transducer – The transducer which does not require the external power source is known as the active transducer. Such type of transducer develops their own voltage or current, hence known as a self-generating transducer. The output signal is obtained from the physical input quantity.

Passive Transducer – The transducer which requires the power from an external supply source is known as the passive transducer. They are also known as the external power transducer. The capacitive, resistive and inductive transducers are the example of the passive transducer.

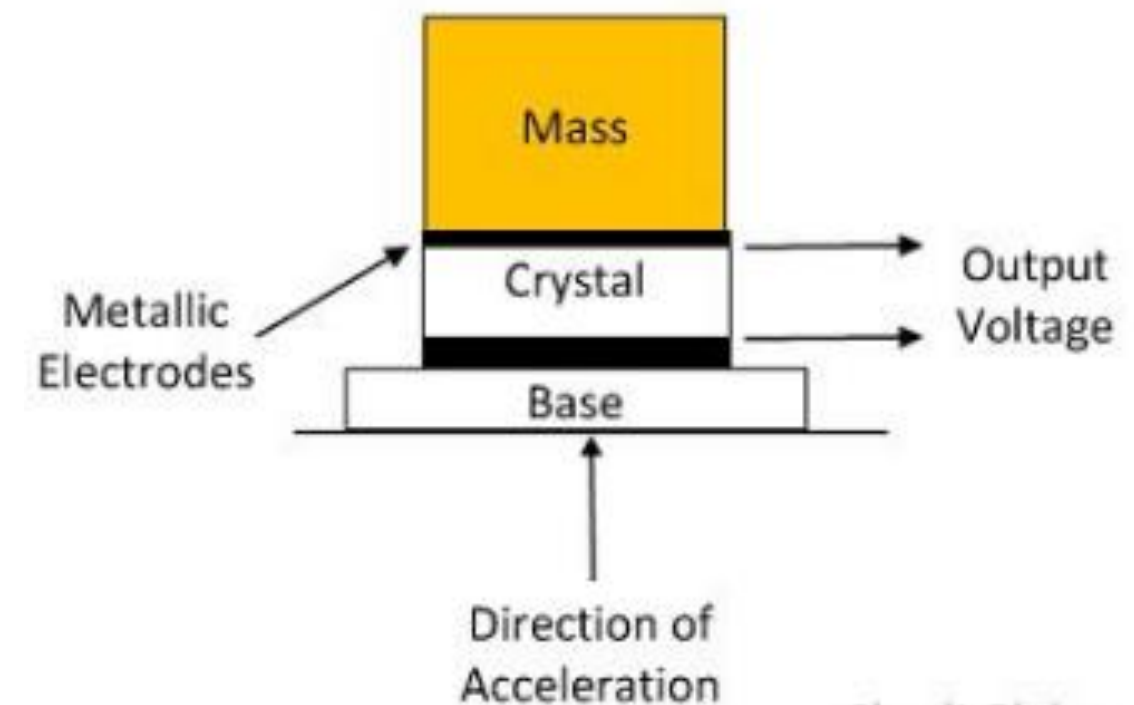

- This transducer is known as the accelerometer which converts the acceleration into an electric voltage.
- This transducer does not require any auxiliary power source for the conversion of physical quantity into an electrical signal.



ANALOG & DIGITAL TRANSDUCER



The transducer can also be classified by their output signals. The output signal of the transducer may be continuous or discrete.





TRANSDUCER & INVERSE TRANSDUCER



Transducer – The device which converts the non-electrical quantity into an electric quantity is known as the transducer.

Inverse Transducer – The transducer which converts the electric quantity into a physical quantity, such type of transducers is known as the inverse transducer. The transducer has high electrical input and low non-electrical output.



Transducer



Inverse Transducer

