



SNS COLLEGE OF TECHNOLOGY

(An Autonomous Institution)

COIMBATORE-35

**Accredited by NBA-AICTE and Accredited by NAAC – UGC with A++ Grade
Approved by AICTE, New Delhi & Affiliated to Anna University, Chennai**

DEPARTMENT OF ELECTRICAL & ELECTRONICS ENGINEERING

UNIT 2

SMART GRID TECHNOLOGIES – Outage Management System (OMS)

19EEE308 – SMART GRIDS
III year / VI Semester

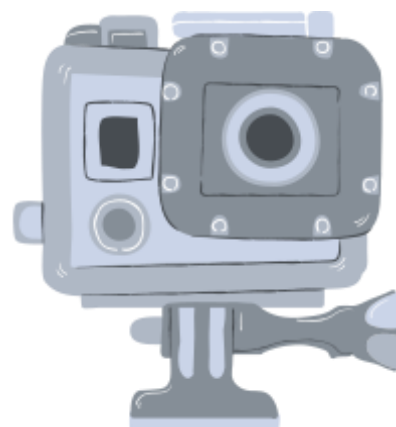



- An outage Management System (OMS) is a computer system and software used by system operators to reduce outage times and help allocate resources for system restoration

Outage Management System

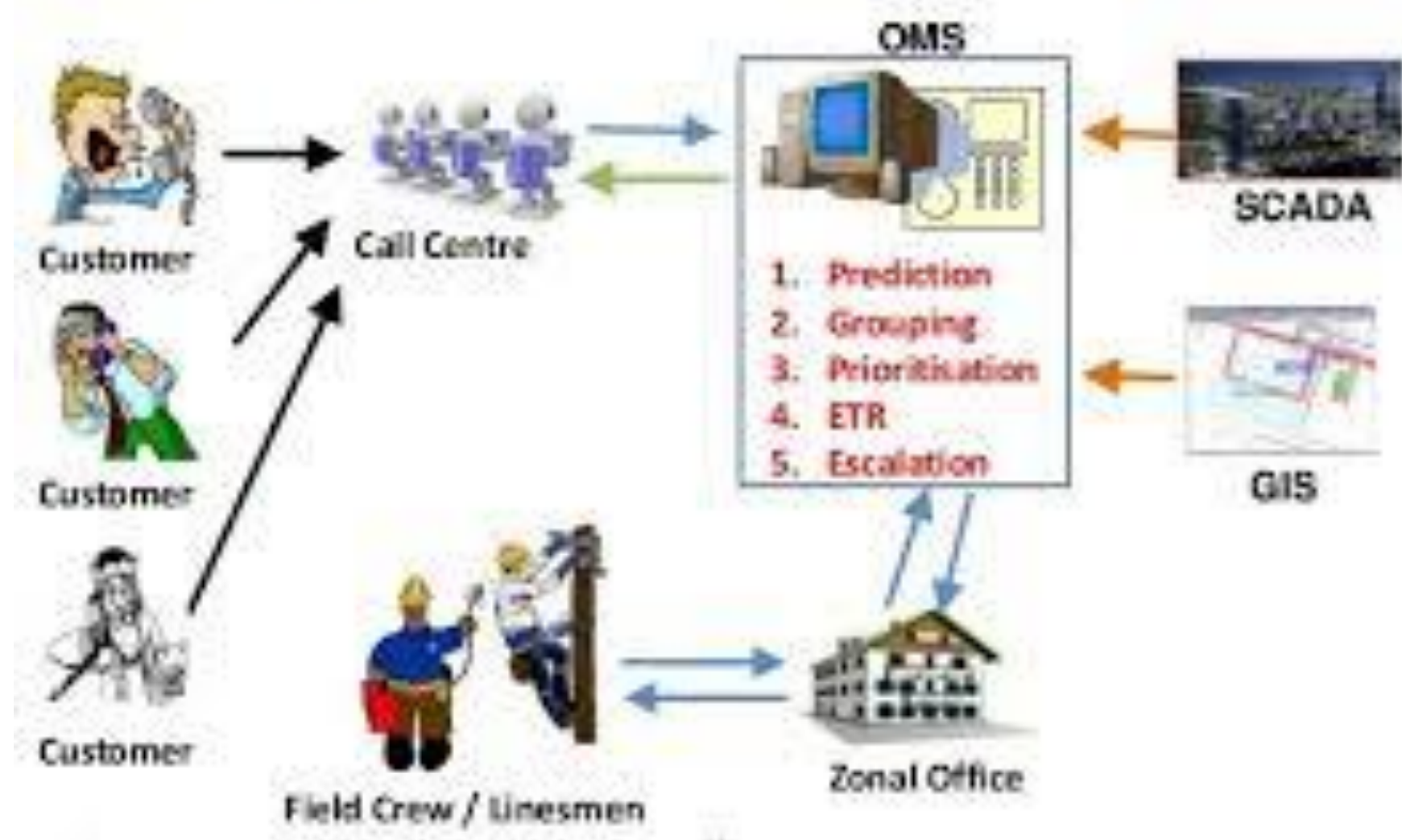

- Geographic Information System (GIS) based.
- Could incorporate Automated meter reading (AMR) or metering infrastructure (AMI) systems.
- Could use information from System Control and Data Acquisition Systems (SCADA)
- Could incorporate data collected at call centers from Customer Information Systems (CIS) or Interactive Voice Response Systems (IVR).
- Can use information from line crews during large outages.



Outage Management System (OMS)



- Utilities are increasingly using Outage Management Systems to aid in handling system repair.
- Systems have grown over the years from an amalgamation of smaller systems designed for other uses.
 - Trouble Tickets
 - AMR Systems
 - Sometimes “home grown”
 - Were not designed to handle wide-scale outages.
- Newer integrated outage management systems better integrate a variety of data.
 - Contain algorithms to track outages and repair status.
 - Can better handle large outages

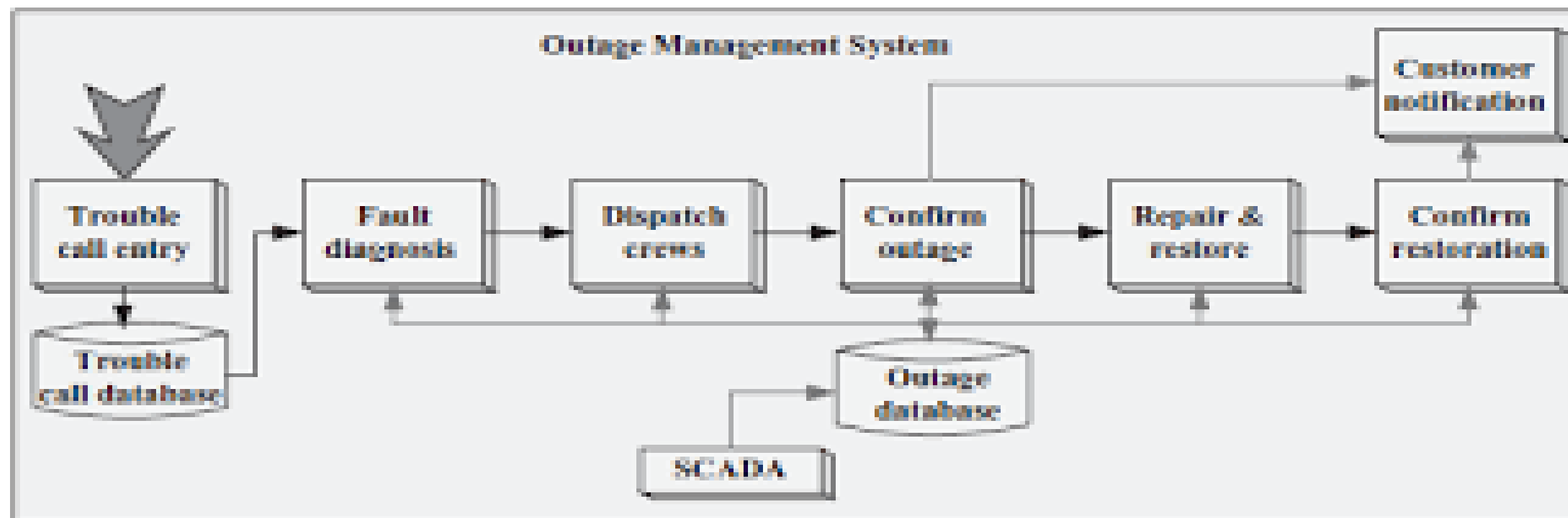



Outage Management System (OMS)

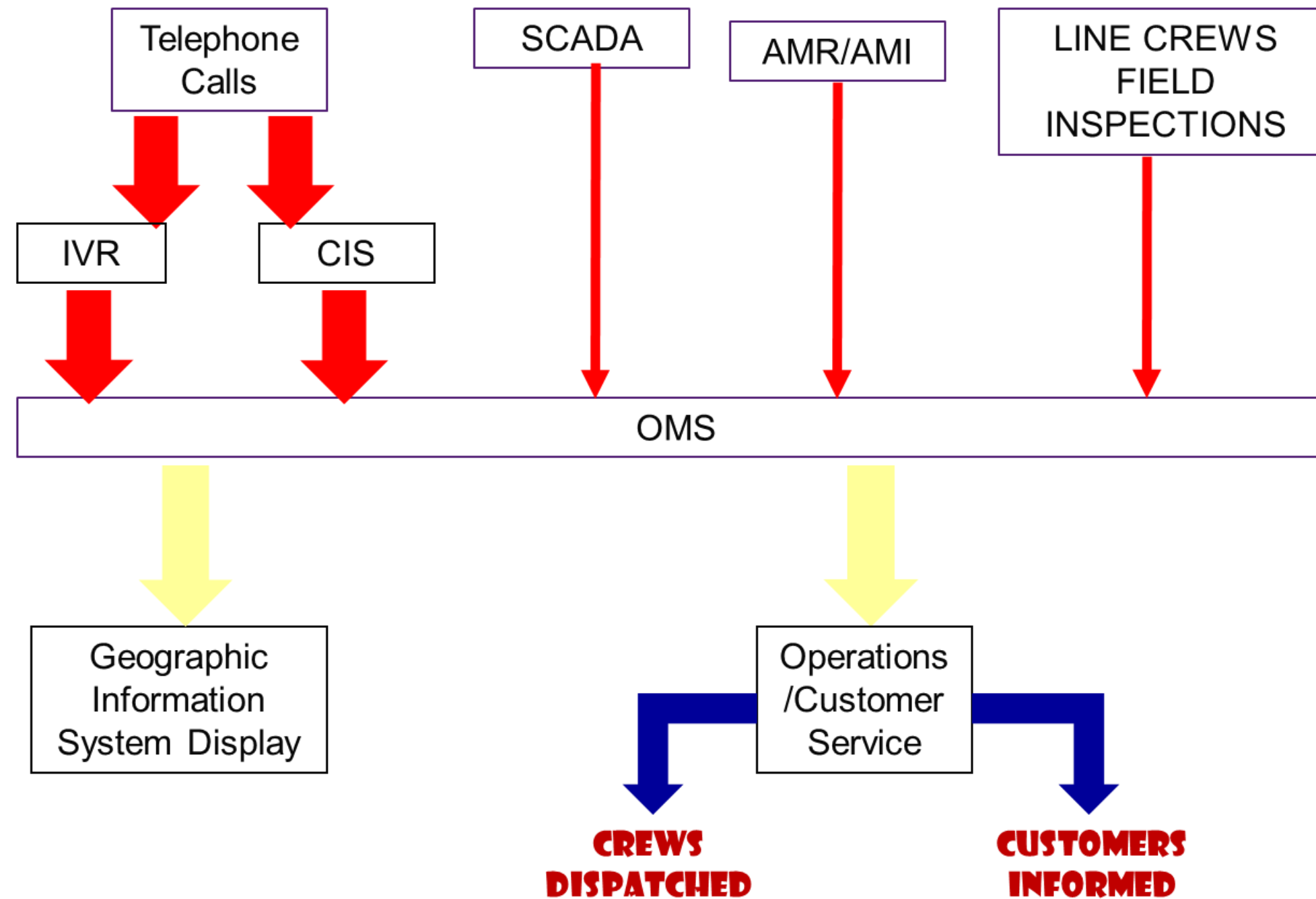



Outage Management System (OMS)

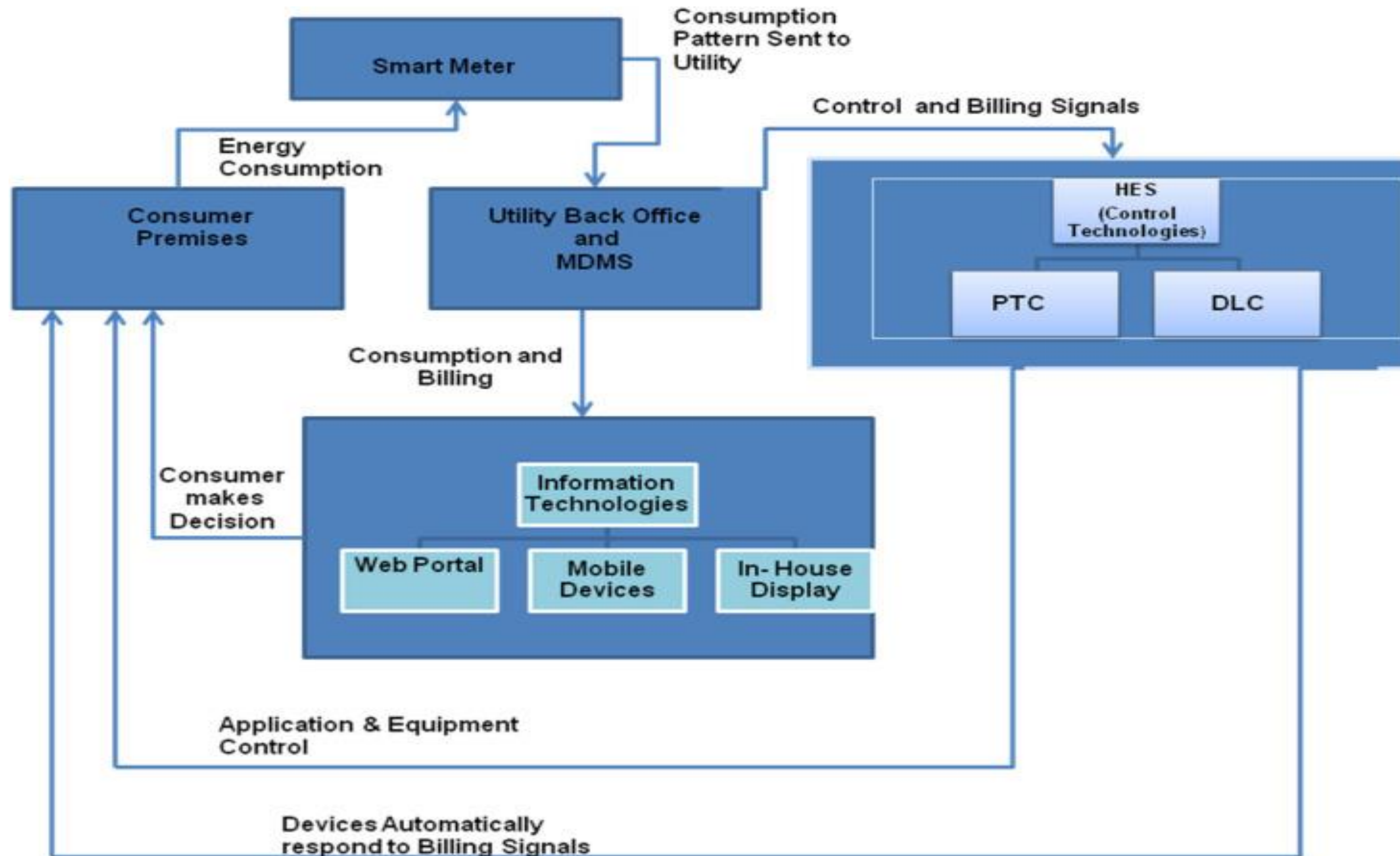



Outage Management System (OMS)

sns
INSTITUTIONS



- Integrates coordinates and displays data from many sources.
- Includes computer algorithms to aid the decision making process.
 - Helps in assessing where troubles exist and how extensive the outage is.
 - Helps to identify which customers are affected.
 - Helps prioritize restoration efforts.
 - Helps in calculating restoration time.
 - Helps manage crews and other resources.
 - Keeps track of critical infrastructure such as centers and fire departments so restoration can be prioritized.
- One step on the way to the “smart grid.”



NEED for Effective - Outage Management System (OMS)



- Utilities may need to re-think how they respond to trouble calls and issue work tickets.
 - How are calls handled? By operations or customer service?
 - How are trouble calls routed to the correct person so action may be taken?
 - Training is needed for all employees involved in its use.

- Good communication within the utility.
 - There may be multiple customer service centers.
 - There may be multiple SCADA and AMI systems.
 - All the correct data must get to everyone who needs it.

- In a widespread outage the utility backbone must be available.
 - SCADA , AMI and other data is highly dependent on telephone, fiber optic, satellite, and radio systems.
 - These systems may not be controlled by or repairable by the electric utility.
 - Coordination with local telephone/communications companies is vital.



Summary



Activity



**KEEP
LEARNING..
Thank u**

SEE YOU IN NEXT CLASS