



SNS COLLEGE OF TECHNOLOGY

Coimbatore – 35



An Autonomous Institution

Accredited by NBA – AICTE and Accredited by NAAC – UGC with ‘A++’ Grade

Approved by AICTE, New Delhi & Affiliated to Anna University, Chennai

DEPARTMENT OF ELECTRONICS AND COMMUNICATION ENGINEERING

16EC401 / Wireless Communication

IV ECE/ VII SEMESTER

Unit IV - **MULTIPATH MITIGATION TECHNIQUES**

Topic 2 : Equalization-Linear and Non-Linear equalization



Introduction



Two general categories

- Linear equalization
- Nonlinear equalization

Based on

- How the output of an adaptive equalizer is used for subsequent control (feedback) of the equalizer



Types

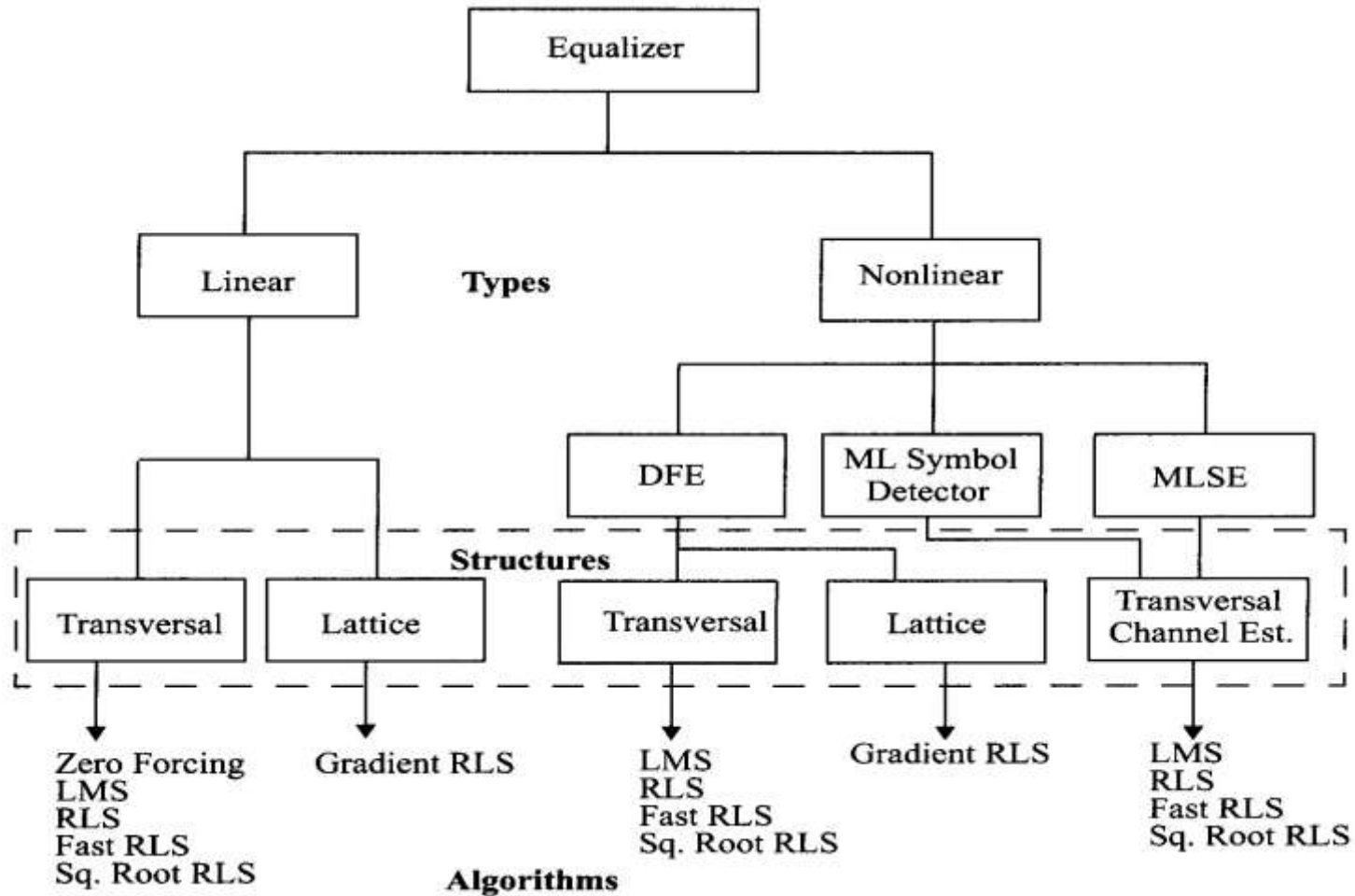



Linear transversal equalizer

- Made up of tapped delay lines
- Tappings spaced a symbol period (T_s) apart

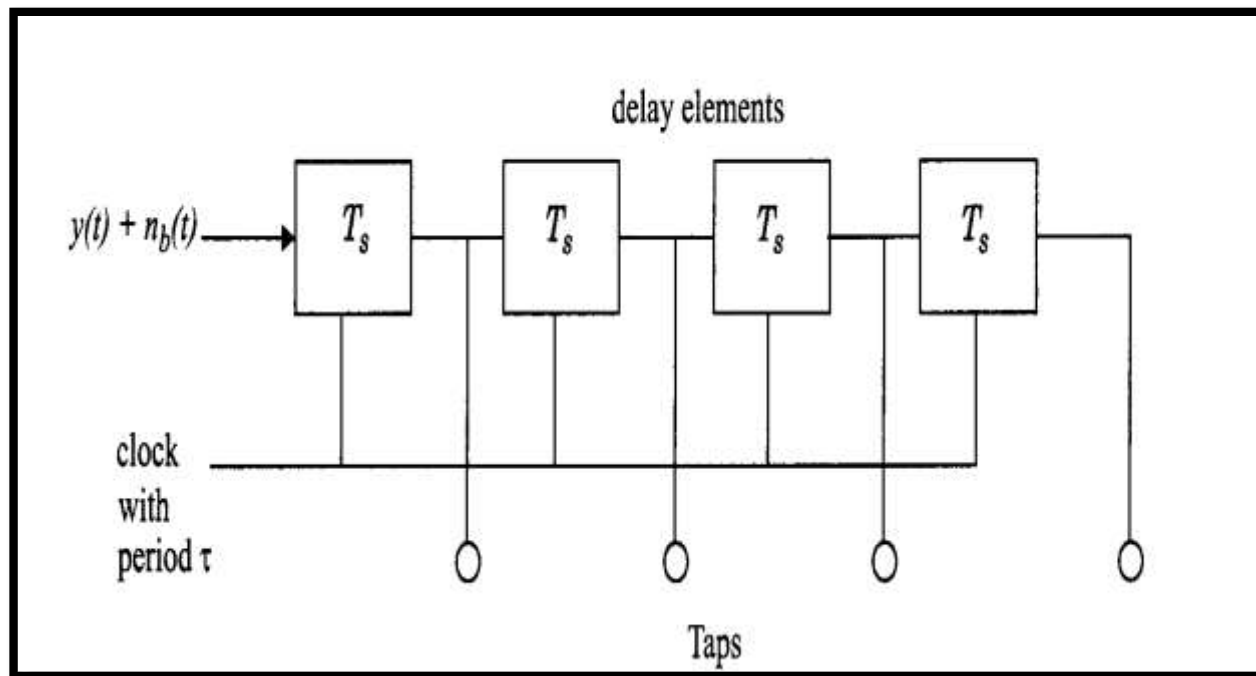

Basic linear transversal equalizer structure



Linear transversal equalizer

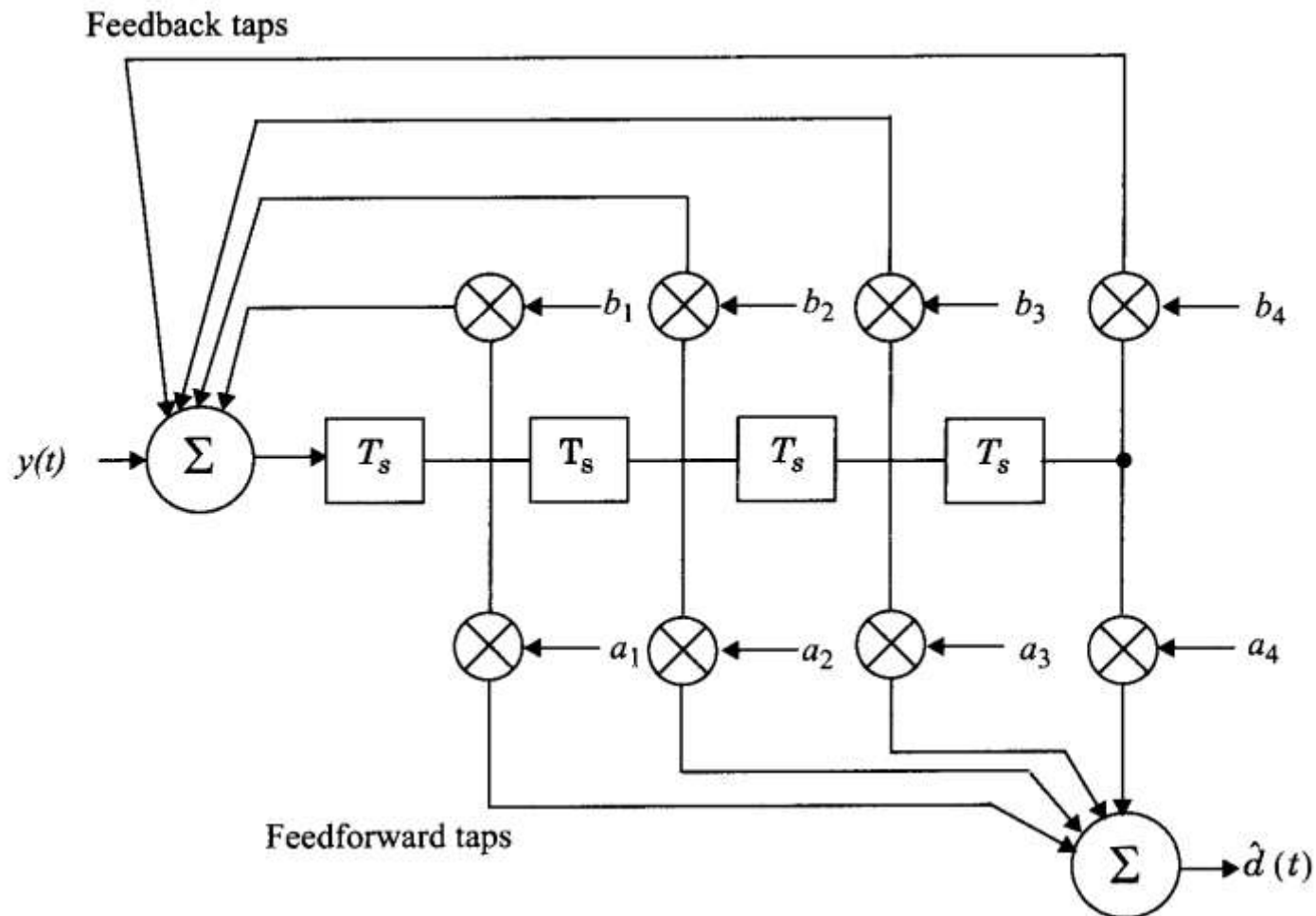

Tapped delay line filter with both feed forward and feedback taps



Structure of Linear transversal equalizer



The current and past values of the received signal are linearly weighted by the filter coefficient and summed to produce the output

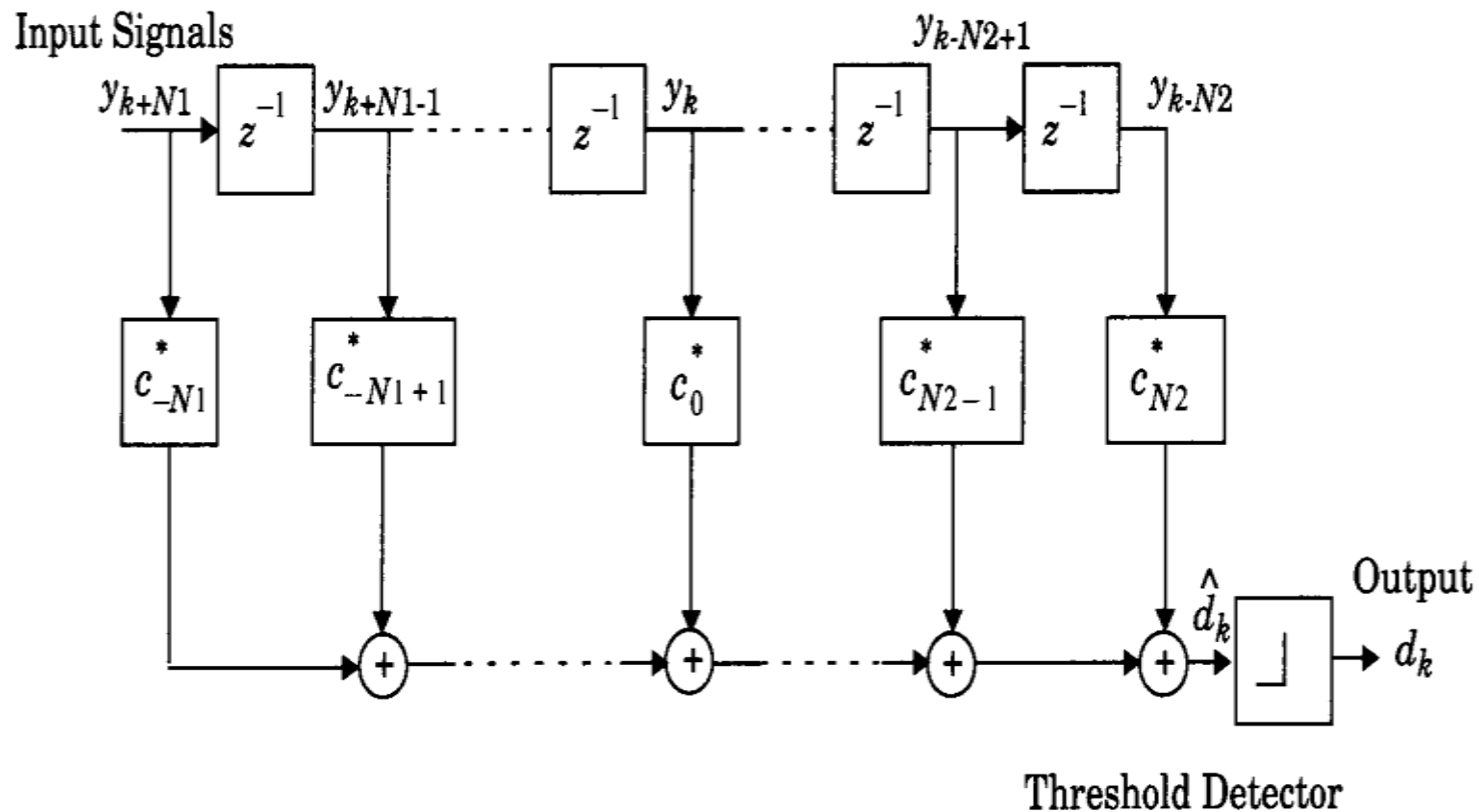



Linear transversal equalizer



The minimum mean squared error $E [e (n)]$ of a linear transversal equalizer can achieve is

$$\hat{d}_k = \sum_{n=-N_1}^{N_2} C_n^* y_{k-n}$$

$$E[|e(n)|^2] = \frac{T}{2\pi} \int_{-\frac{\pi}{T}}^{\frac{\pi}{T}} \frac{N_o}{|F(e^{j\omega T})|^2 + N_o} d\omega$$

$F(e^{j\omega T})$:Frequency response of the channel

N_o :Noise spectral density



Activity



- Imagine folding a paper in half once
- Then take the result and fold it in half again; and so on
- How many times can you do that?



Nonlinear Equalization

- Used in applications where the channel distortion is too severe
- Three effective methods
 - Decision Feedback Equalization (DFE)
 - Maximum Likelihood Symbol Detection
 - Maximum Likelihood Sequence Estimator (MLSE)



Decision Feedback Equalizer



- Basic idea : Once an information symbol has been detected and decided upon, the ISI that it induces on future symbols can be estimated and subtracted out before detection of subsequent symbols
- Realized in either the direct transversal form or as a lattice filter
- It consists of a feed forward filter (FFF) and a feedback filter (FBF)
- The FBF is driven by decisions on the output of the detector
- Its coefficients can be adjusted to cancel the ISI on the current symbol from past detected symbols



DFE

The equalizer has

- $N_1 + N_2 + 1$ taps in the feed forward filter
- N_3 taps in the feedback filter

Its output

$$\hat{d}_k = \sum_{n=-N_1}^{N_2} C_n^* y_{k-n} + \sum_{i=1}^{N_3} F_i d_{k-i}$$

Minimum mean square error

$$E[|e(n)|^2]_{\min} = \exp\left\{\frac{T}{2\pi} \int_{-\frac{\pi}{T}}^{\frac{\pi}{T}} \ln\left[\frac{N_o}{|F(e^{j\omega T})|^2 + N_o}\right] d\omega\right\}$$



DFE

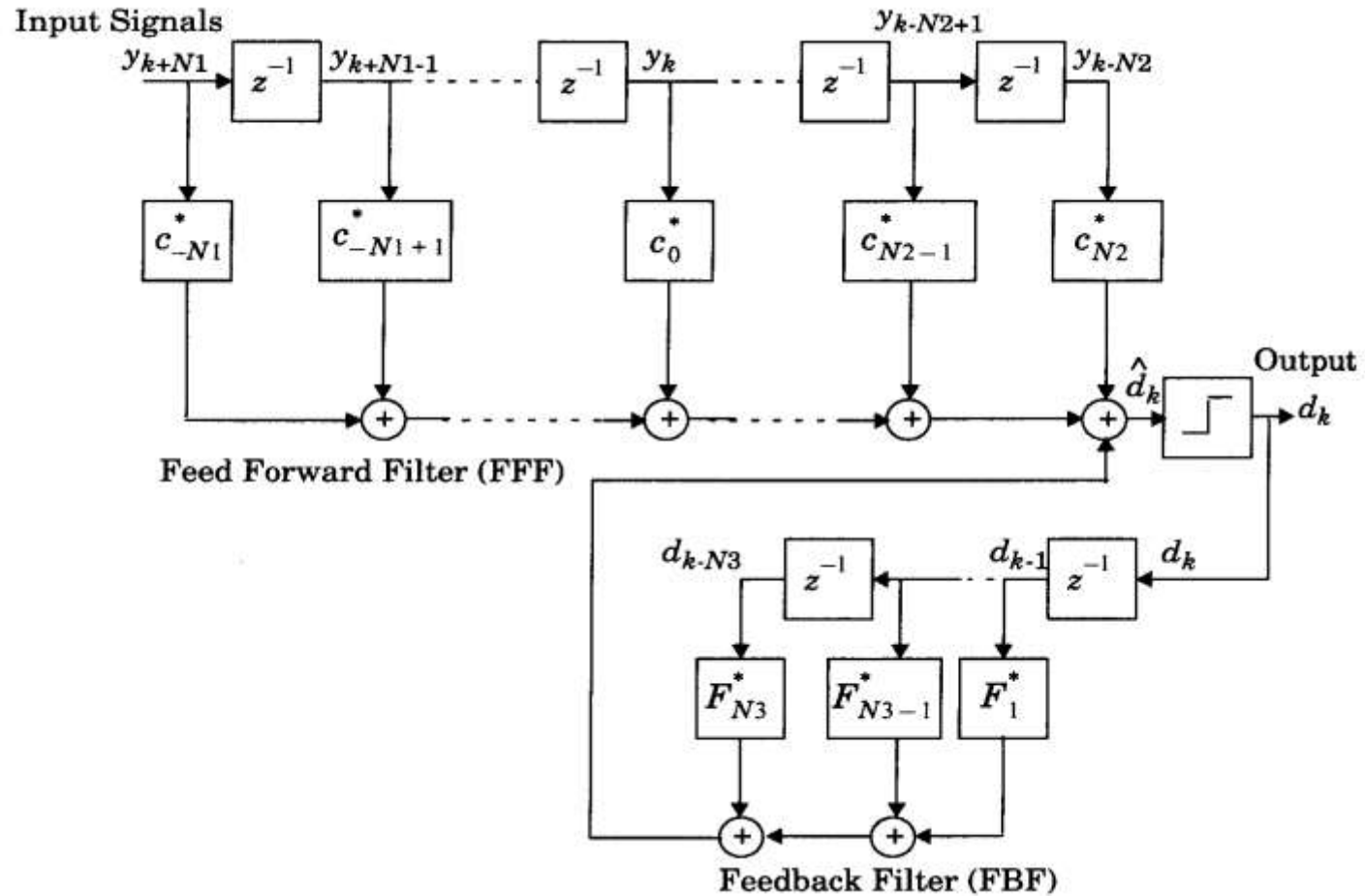



DFE

- *Predictive DFE*
- Consists of an FFF and an FBF, the latter is called a *noise predictor*
- Predictive DFE performs as well as conventional DFE as the limit in the number of taps in FFF and the FBF approach infinity
- The FBF in predictive DFE can also be realized as a lattice structure

The RLS algorithm can be used to yield fast convergence



Predictive decision feedback equalizer

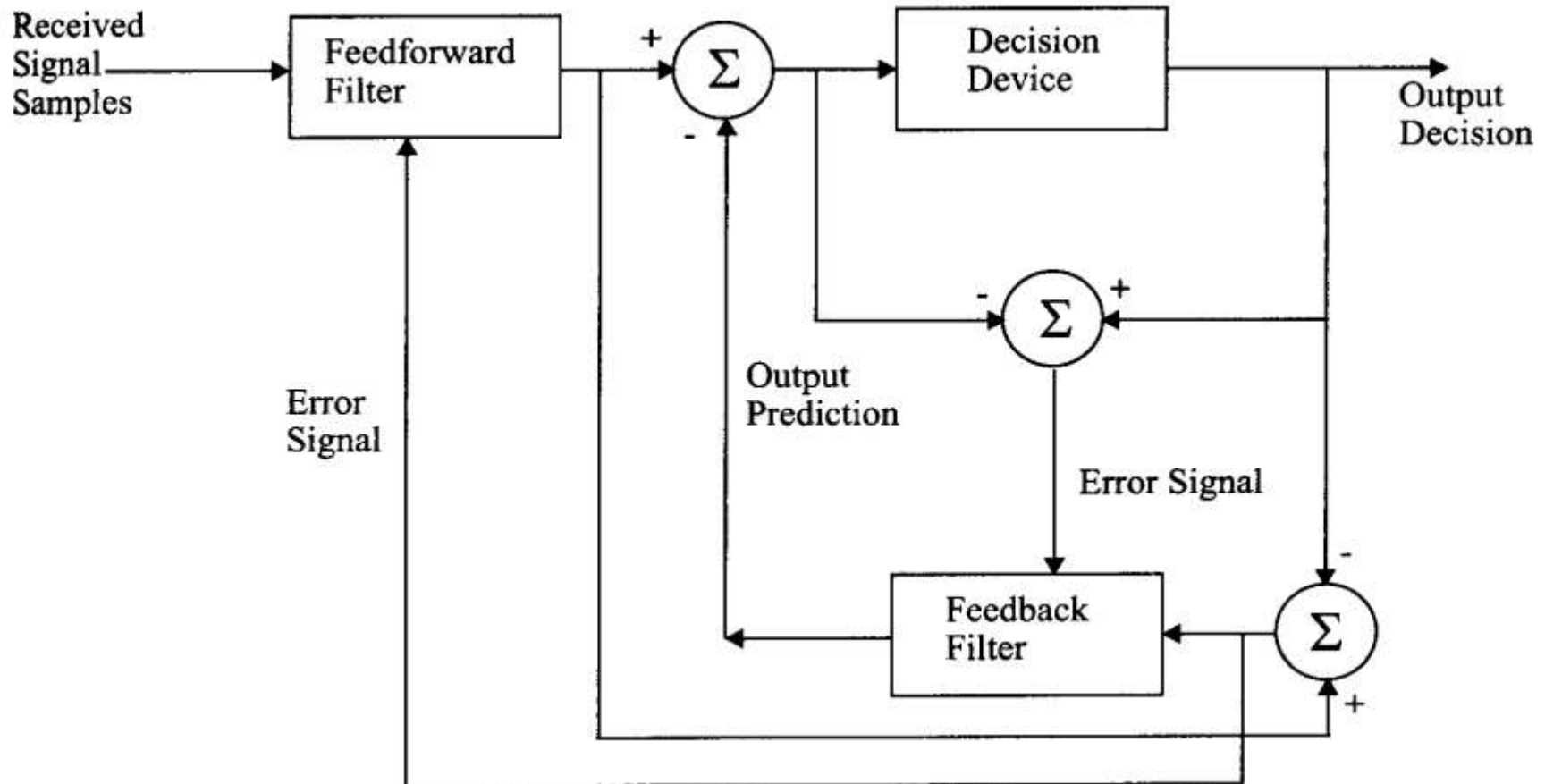



Nonlinear Equalization--MLSE

- MLSE tests all possible data sequences
- Chooses the data sequence with the maximum probability as the output
- Usually has a large computational requirement
- The block diagram of MLSE receiver



Nonlinear Equalization--MLSE

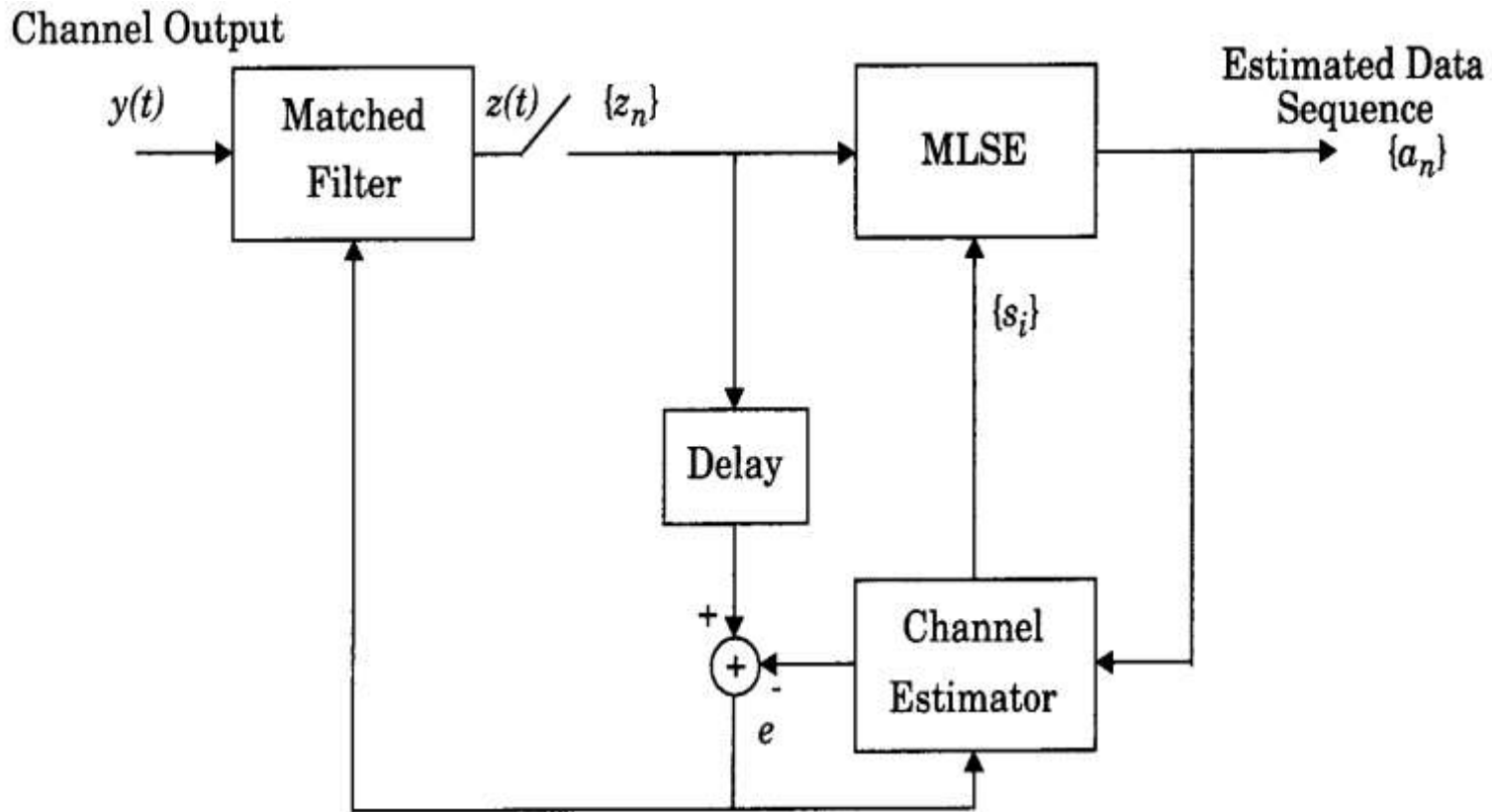

The structure of a maximum likelihood sequence equalizer(MLSE) with an adaptive matched filter



Nonlinear Equalization--MLSE

- MLSE requires knowledge of the channel characteristics in order to compute the matrices for making decisions
- MLSE also requires knowledge of the statistical distribution of the noise corrupting the signal



Assessment



➤ **The decision feedback equalizer has a linear traversal**

- a) **Feed forward section**
- b) Feedback section
- c) Both of the mentioned
- d) None of the mentioned



➤ **Choice of equalizer structure and its algorithm is not dependent on _____**

- a) Cost of computing platform
- b) Power budget
- c) Radio propagation characteristics
- d) **Statistical distribution of transmitted power**



THANK YOU