



SNS COLLEGE OF TECHNOLOGY

Coimbatore-35
An Autonomous Institution



Accredited by NBA – AICTE and Accredited by NAAC – UGC with 'A++' Grade
Approved by AICTE, New Delhi & Affiliated to Anna University, Chennai

DEPARTMENT OF ELECTRONICS & COMMUNICATION ENGINEERING

19ECT311 / Wireless Communication

III ECE/ VI SEMESTER

Unit III - **CELLULAR NETWORKS**

TOPIC – OFDM



WHY OFDM?



- OFDM stands for Orthogonal Frequency Division Multiplexing
- It is a modulation technique for transmitting large amounts of digital data over a radio wave.

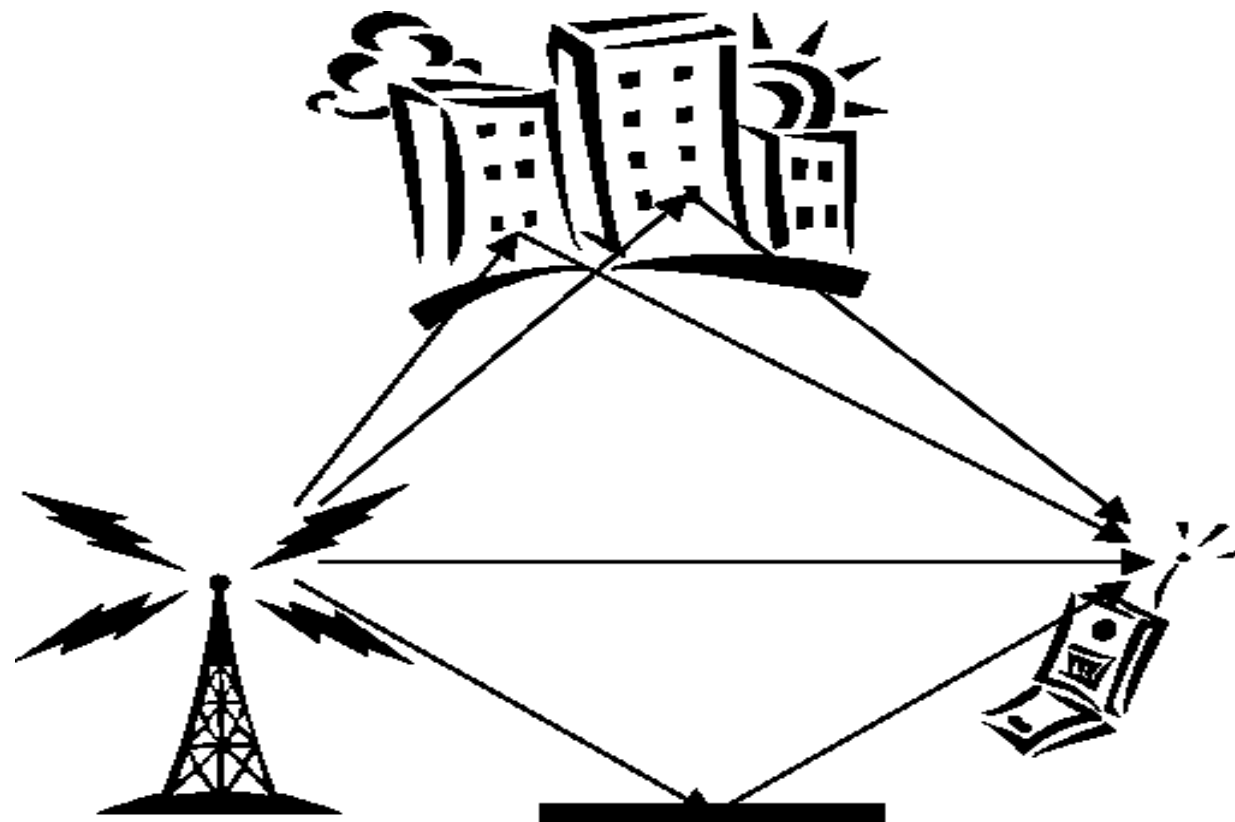



HOW OFDM DIFFER FROM OTHERS?



*Orthogonality:

- The “orthogonal” part of the OFDM name indicates that there is a precise mathematical relationship between the frequencies of the carriers in the system
- **Wireless** The OFDM modulation scheme offers many advantages for broadband wireless transport. -It supports high data rates

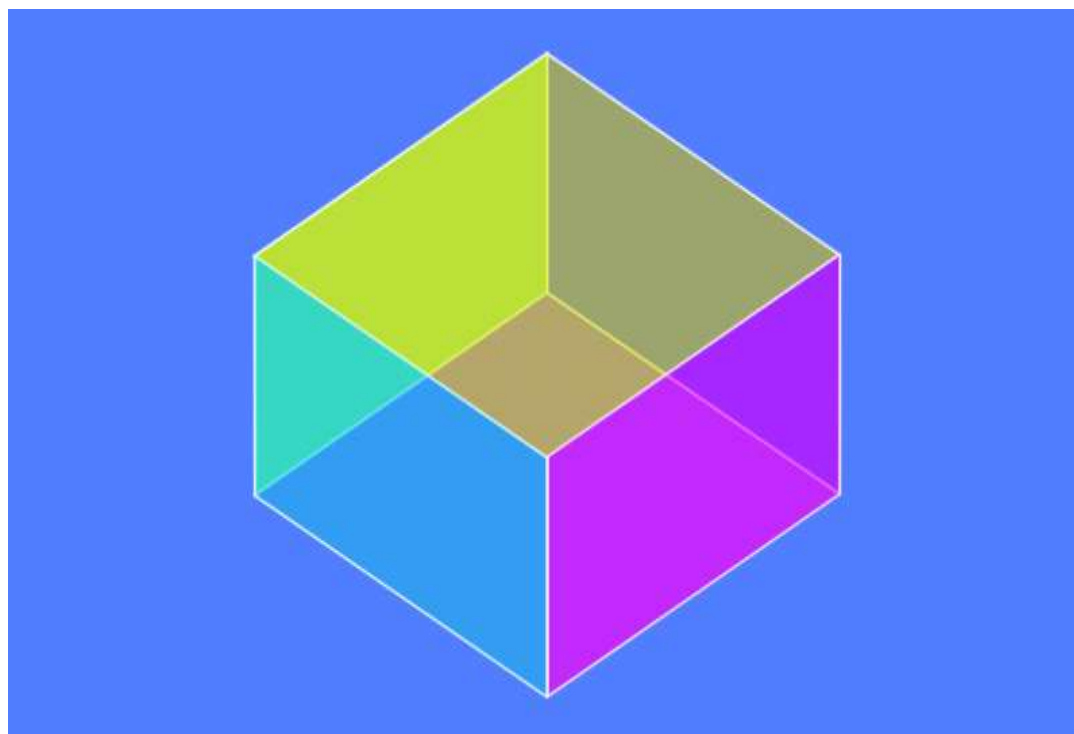



OFDM CONCEPTS



- OFDM is a special case of FDM

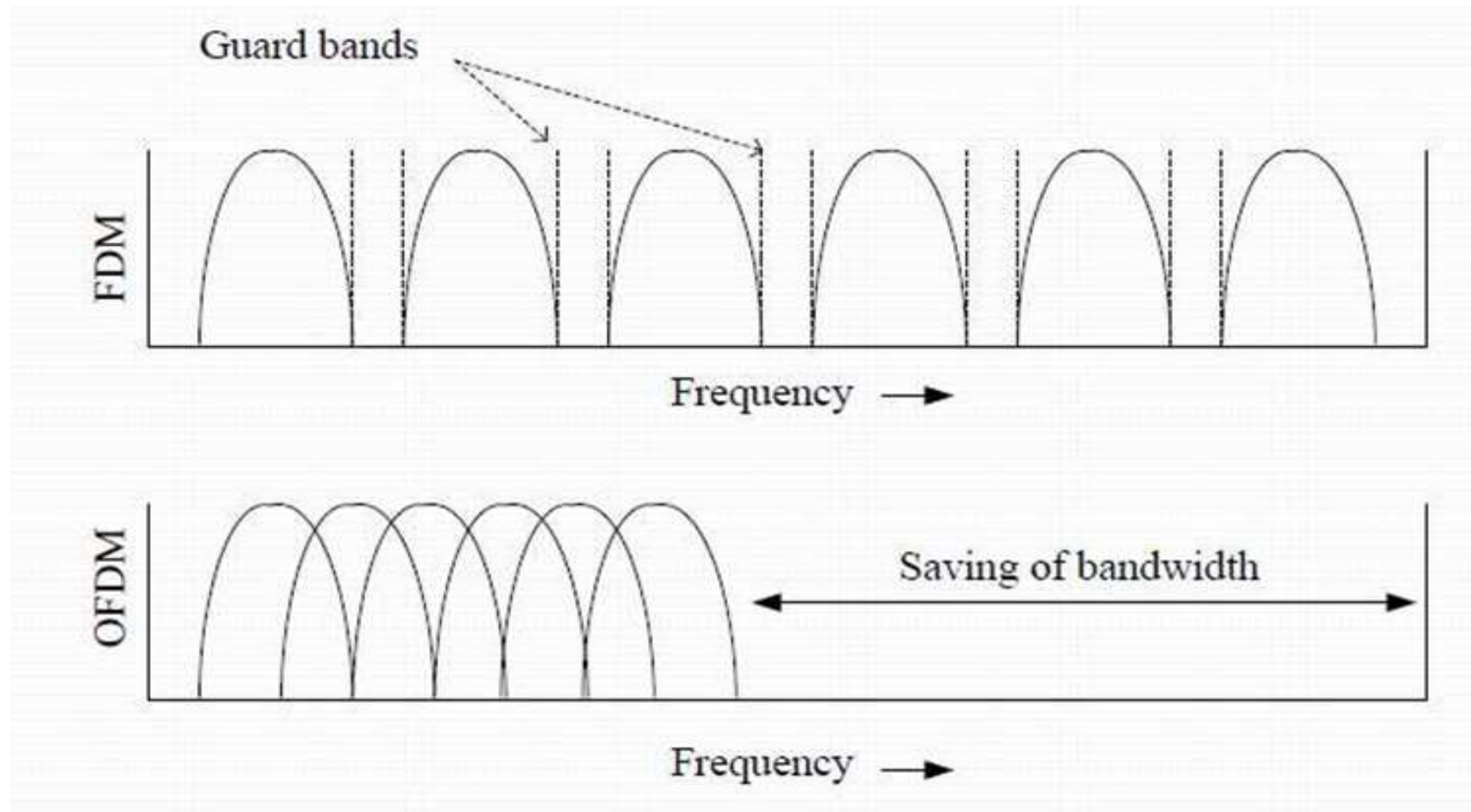



OFDM CONCEPTS



- System bandwidth is divided into a set of parallel overlapping
- Orthogonal sub-bands independent to each other
- Data is first split into independent streams, which modulate different sub-carriers, then are multiplexed to create OFDM signal

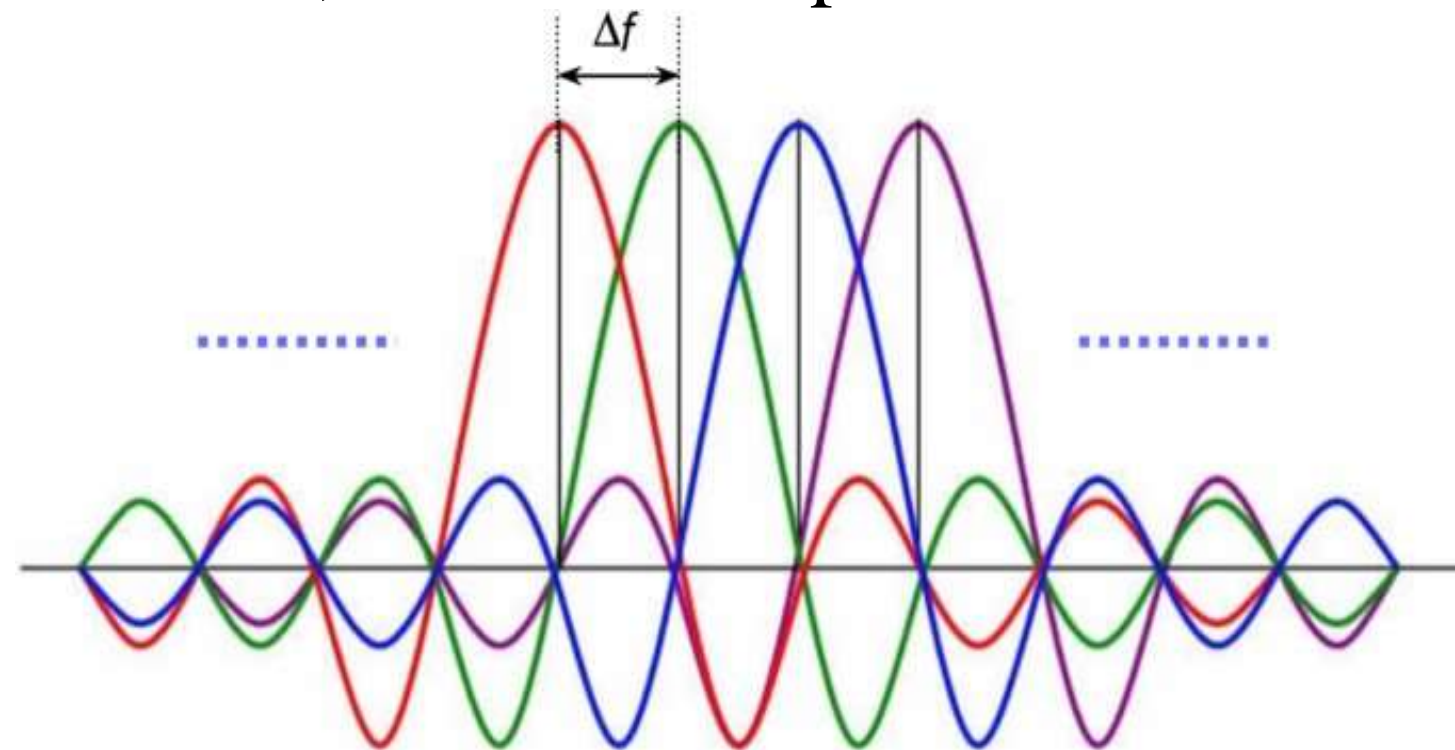

Sub carriers



OFDM CONCEPTS



- Significantly improves spectral efficiency
- Avoid the need for steep band pass filters
- Avoids the need of a bank of oscillators, since can be implanted digitally



MULTICARRIER MODULATION



- **Divide broadband channel into narrowband subchannels**
 - No ISI in *subchannels* if constant gain in every subchannel and if ideal sampling
- **Orthogonal Frequency Division Multiplexing**
 - Based on the fast Fourier transform
 - Standardized for DAB, DVB-T, IEEE 802.11a, 802.16a, HyperLAN II
 - Considered for fourth-generation mobile communication systems

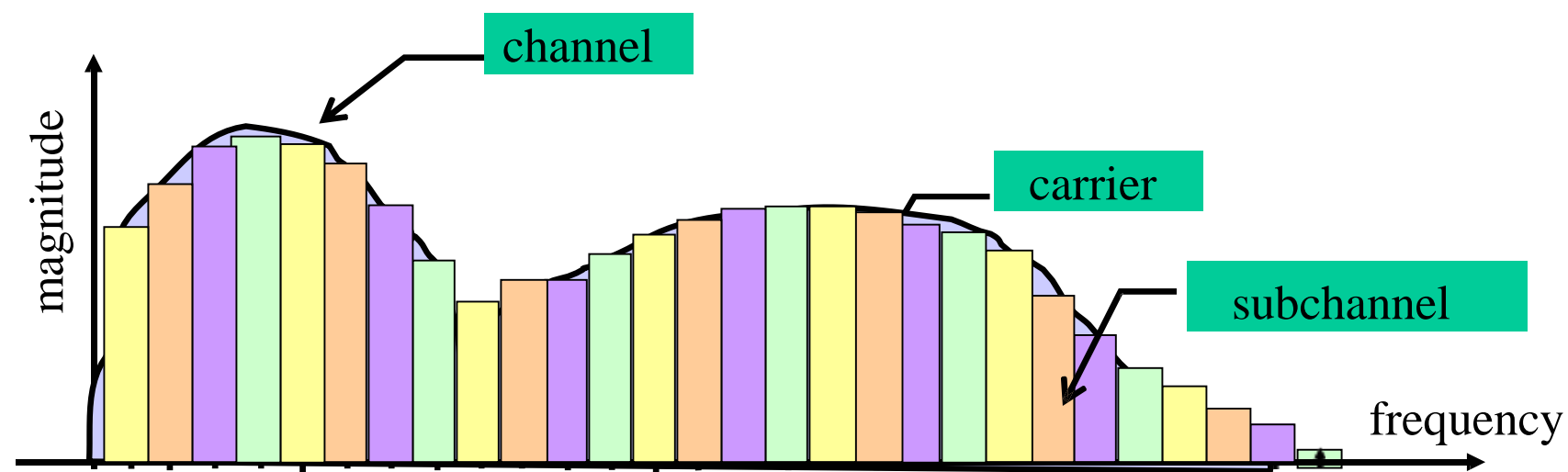

Subchannels are 312 kHz wide in 802.11a and HyperLAN II



ACTIVITY



In class activity

Motivational video

<https://www.youtube.com/watch?v=RDKMfmpo7gc>



OFDM BLOCK DIAGRAM



- Orthogonal Frequency Division Multiplexing
 - Split a high symbol rate data stream into N lower rate streams
 - Transmit the N low rate data streams using N subcarriers
 - Frequency Division Multiplexing (FDM) & Multi-Carrier Modulation (MCM)
 - N subcarriers must be mutually orthogonal

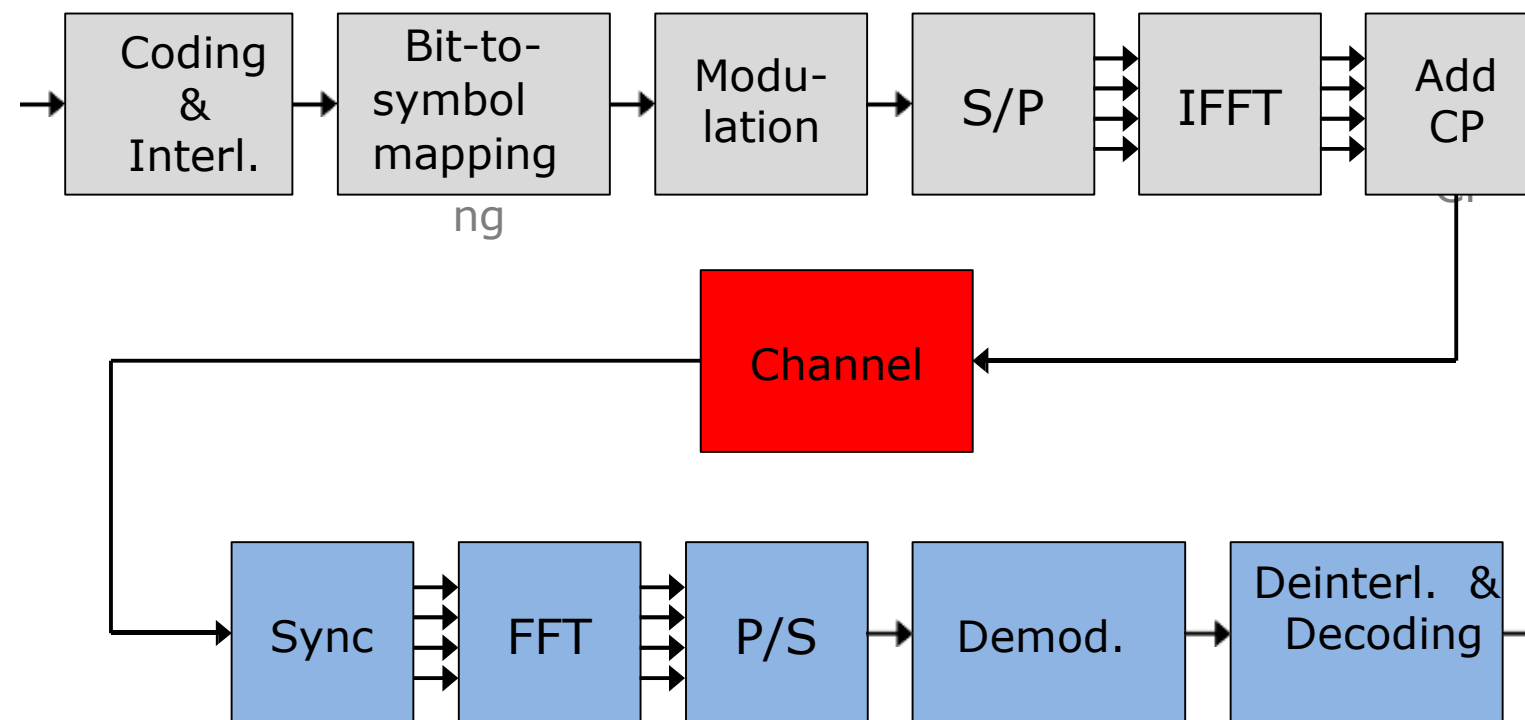



OFDM TRANSMITTER

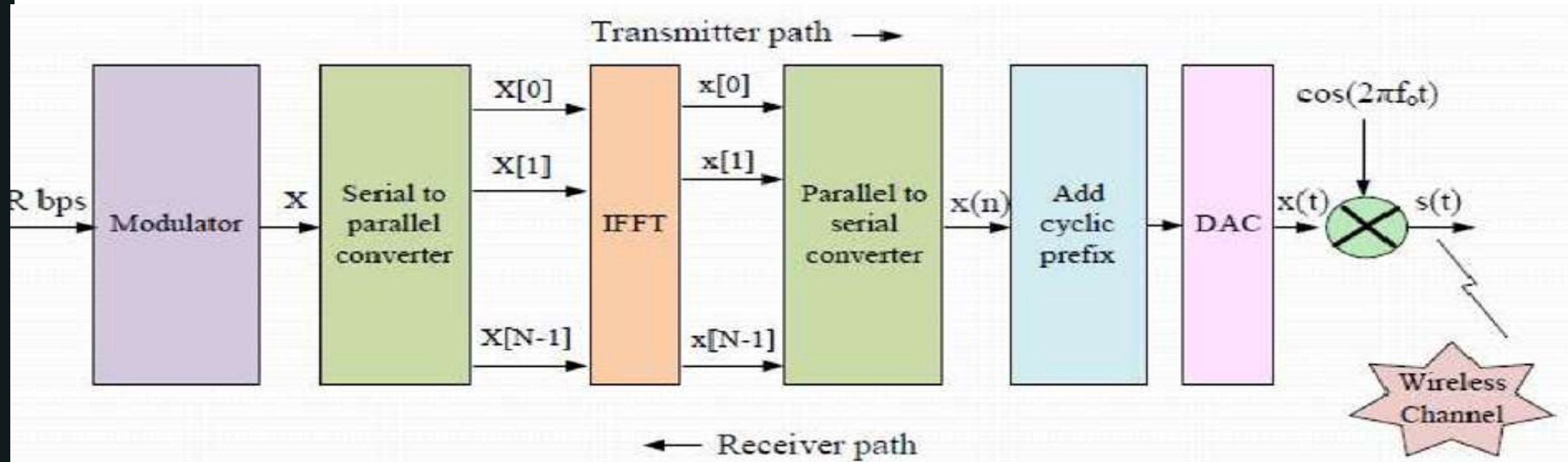



OFDM RECEIVER

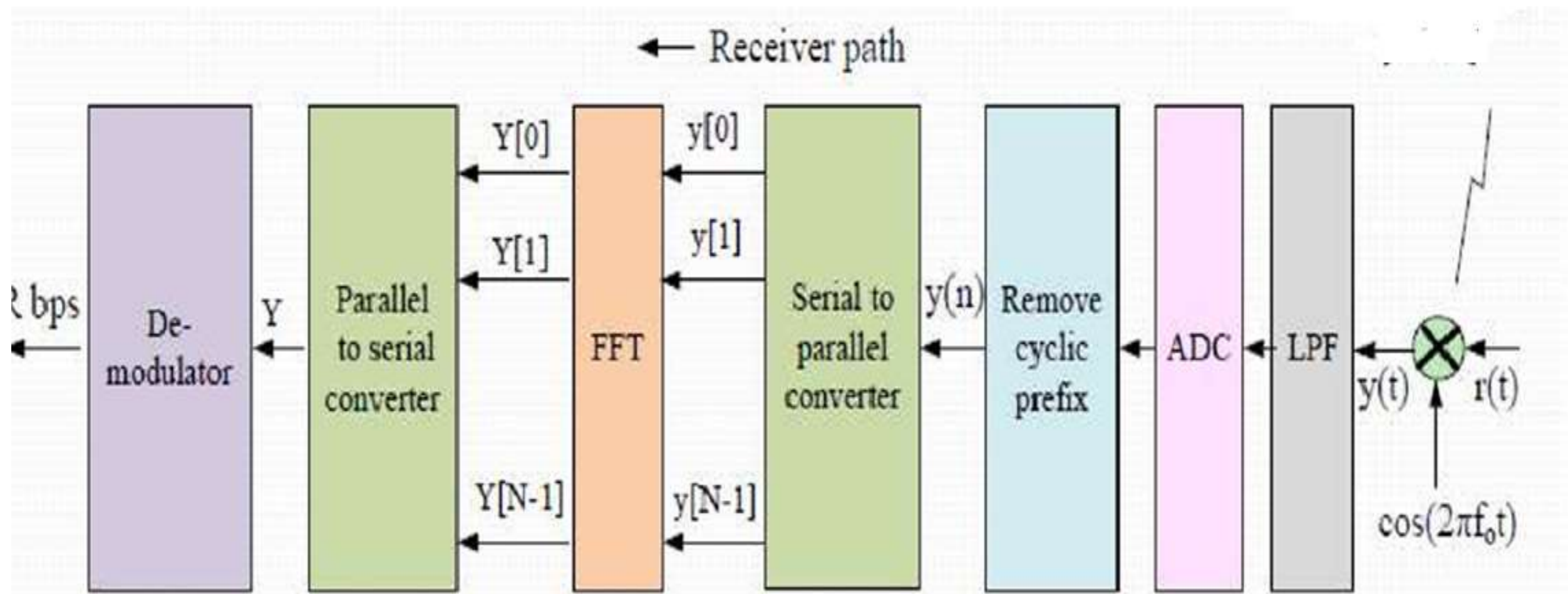



OFDM

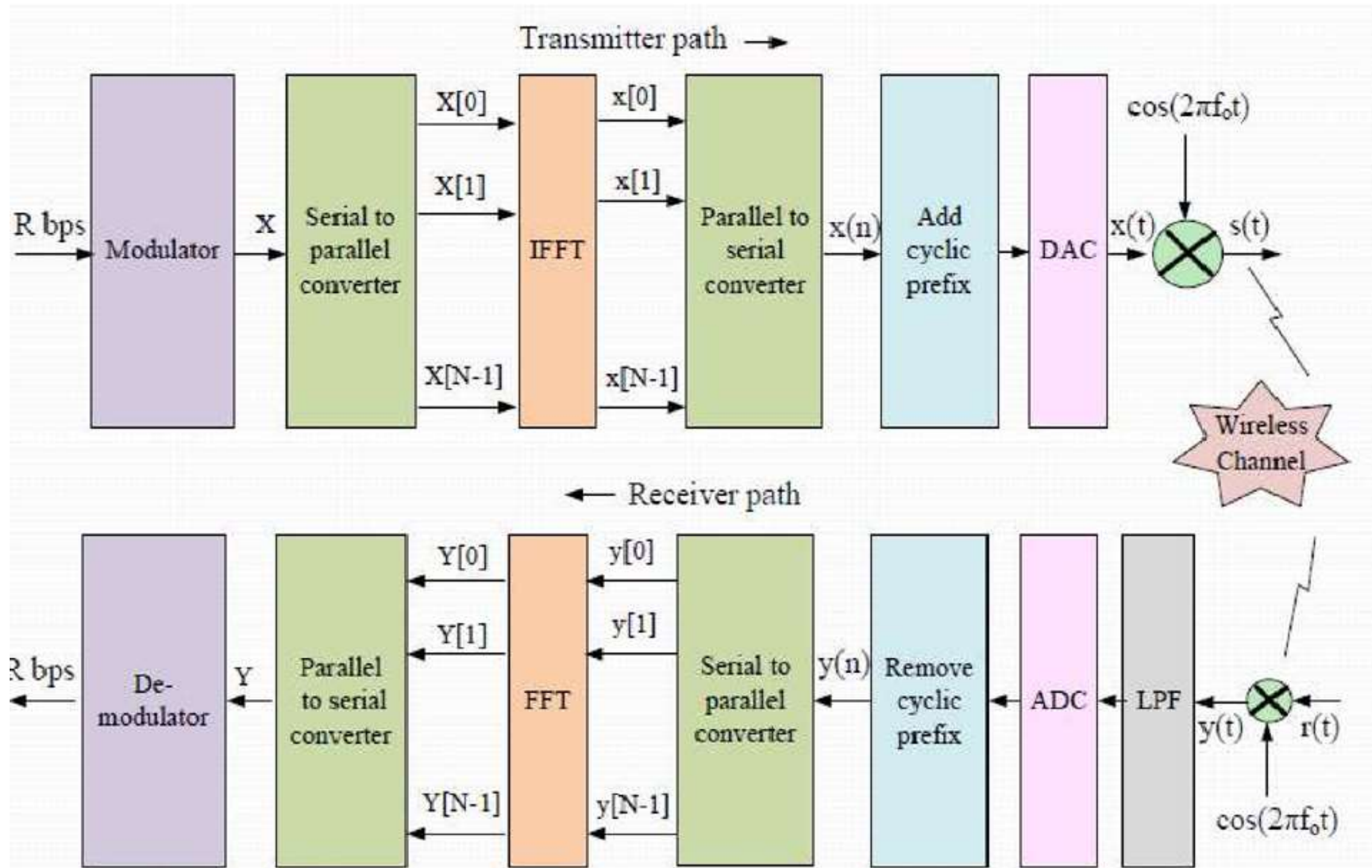



SUB CHANNELS SPECTRUM



Single subchannel

OFDM spectrum

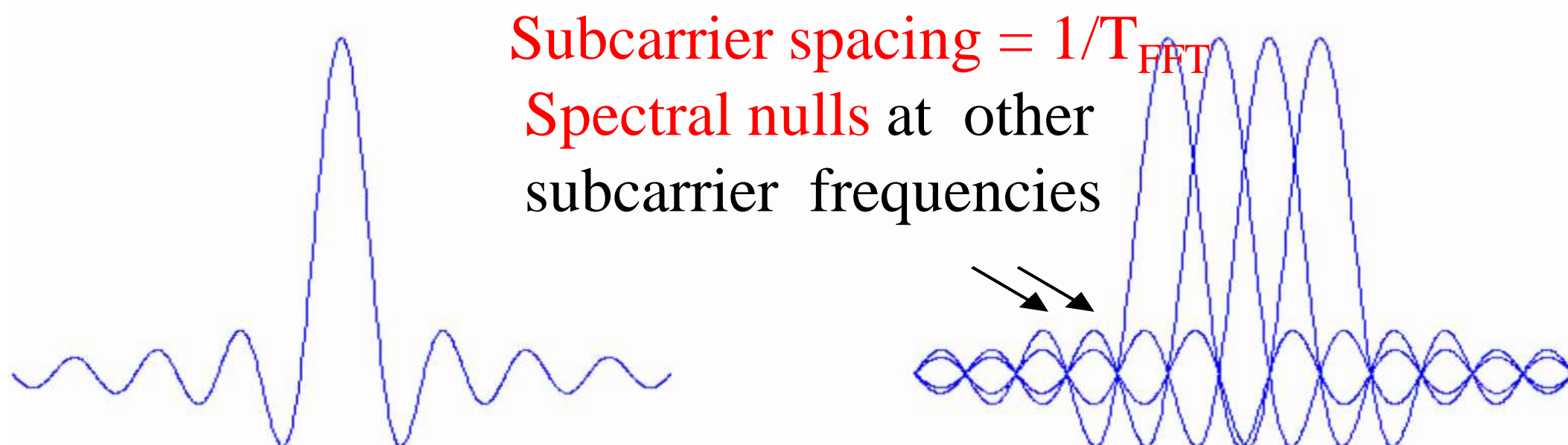



OFDM ADVANTAGES



HIGH PAPR

- A number of independently modulated sub-carriers result in **HIGH PAPR**
- Non-linear power amplifier, efficient, but cannot be used
 - Causing performance degradation due to high distortion & out of band radiations
- High PAPR also increases complexity of ADC & DAC

FREQUENCY OFFSET

- Sub-carriers are very close and overlapping
- Even a small frequency offset will result in ISI
- Causes of frequency offset:

Frequency mismatch in local oscillators of transmitter & receiver
Doppler shift
Phase noise caused in the channel



OFDM ADVANTAGES



- OFDM is slightly more tolerant to time offset, compared to frequency offset
- Causes lack of precision in symbol boundaries, resulting in ISI
- ISI occur only when time offset differs from CP duration
- Causes phase change & may also result in frequency offset

OFDM demands strict synchronization in frequency & time to preserve orthogonality



CONCLUSION



- Hence synchronization is necessary in OFDM because it minimizes performance degradation

- **Synchronization Methods**

Several approaches to estimate jointly or individually, used iteratively or in one step

- 1.Data aided method (pilot based)
- 2.Non-data aided method (blind)
- 3.Hybrid method



ASSESSMENT



1. What is OFDM?

2. State the advantages of OFDM.





THANK YOU