



SNS COLLEGE OF TECHNOLOGY

An Autonomous Institution

Coimbatore-35



Accredited by NBA – AICTE and Accredited by NAAC – UGC with 'A+' Grade
Approved by AICTE, New Delhi & Affiliated to Anna University, Chennai

DEPARTMENT OF ELECTRONICS & COMMUNICATION ENGINEERING

19ECB212 – DIGITAL SIGNAL PROCESSING

II YEAR/ IV SEMESTER

UNIT 2 – IIR FILTER DESIGN

TOPIC – REALIZATION STRUCTURES FOR IIR FILTERS



Z TRANSFORM



- Z transform is used for the analysis of discrete time signals.
- It is more broad compared to Discrete Time Fourier Transform
- It is very much useful in discrete time signals as well as system analysis
- $x(n)$ and $X(Z)$ is called Z transform pair

$x(n)$ \longleftrightarrow $X(Z)$

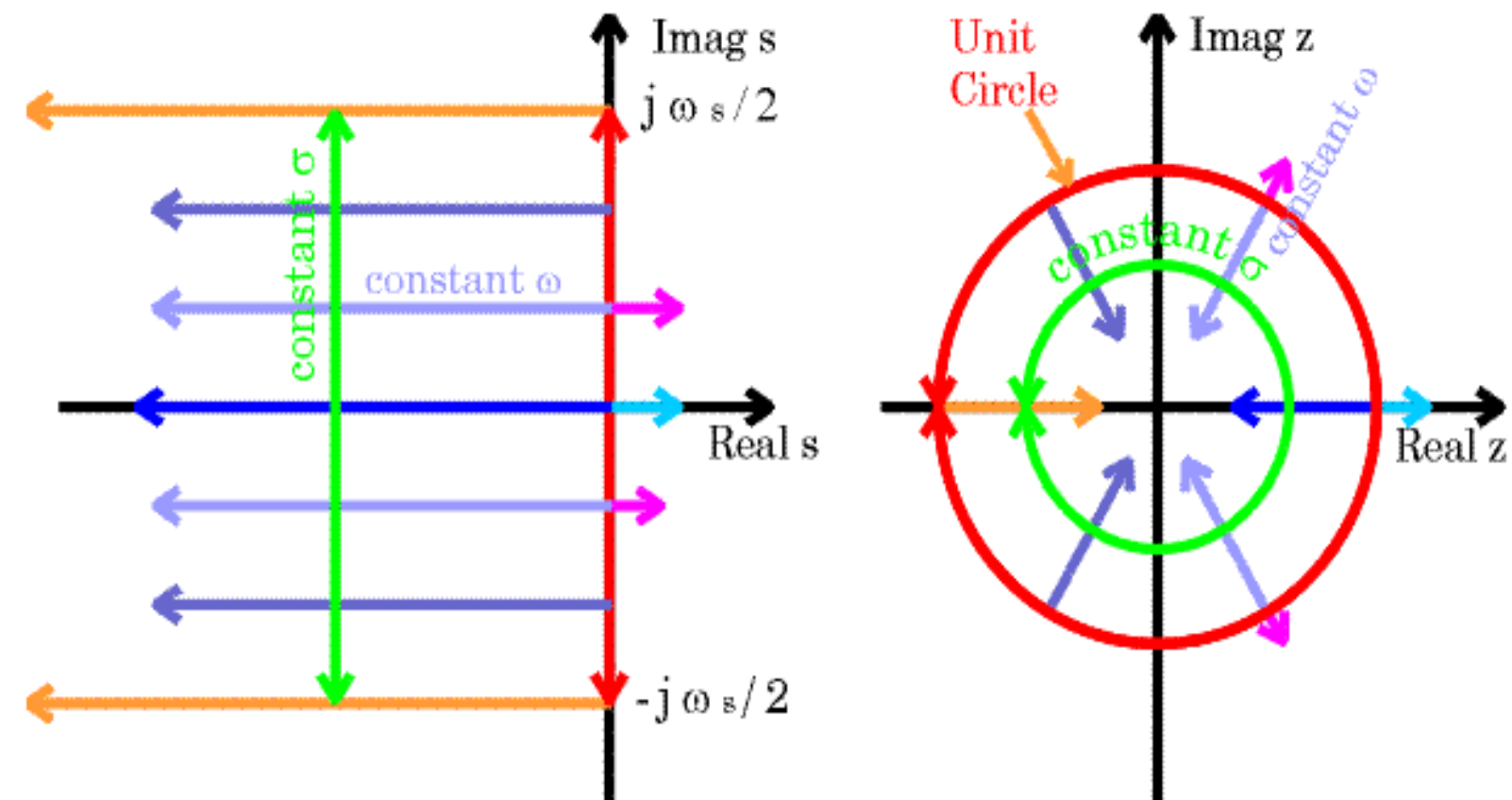



LTI DT SYSTEM



- **System Transfer Function:** Ratio of the output to the input.

$$H(Z) = \frac{Y(Z)}{X(Z)}$$

- **Frequency Response:**

$$H(\omega) = \frac{Y(\omega)}{X(\omega)}$$



DIFFERENCE EQUATION



- **Difference Equation:** It is an efficient way to implement discrete time systems
- The convolution of input sequence $x(n)$ and unit sample response $h(n)$ gives the output $y(n)$

$$y(n) = \sum_{k=-\infty}^{\infty} x(k) h(n - k)$$

- Two types of systems depending upon the length of unit sample response $h(k)$



LTI DISCRETE TIME SYSTEMS



- **Finite Impulse Response (FIR) Systems:** Unit sample response (or) Impulse response $h(n)$ has finite no. of terms

$$y(n) = \sum_{k=0}^{M-1} h(k) x(n - k)$$

- **Infinite Impulse Response (IIR) Systems:** Length of Unit sample response (or) Impulse response $h(n)$ is infinite

$$y(n) = \sum_{k=0}^{\infty} h(k) x(n - k)$$



LTI DISCRETE TIME SYSTEMS



- **Recursive Systems:** Output $y(n)$ depends on present and past inputs as well as past output

$$y(n) = \sum_{k=0}^n x(k)$$

- **Non Recursive Systems:** Output $y(n)$ depends on present and past input.

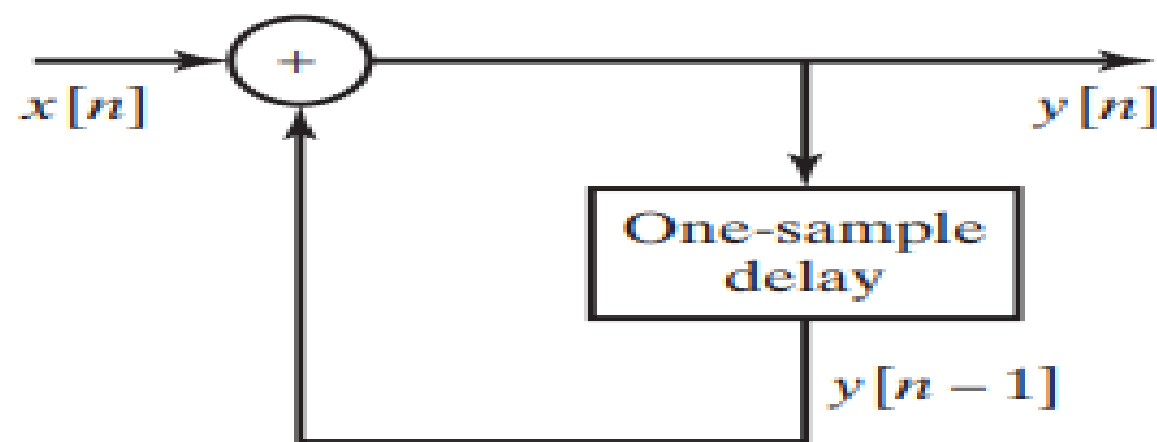

$$y(n) = \sum_{k=0}^M h(k) x(n - k)$$



BLOCK DIAGRAM



- The discrete time systems are represented by block diagrams.
- They are also called structures of discrete time systems.
- It can be classified into four types
 1. Direct Form I
 2. Direct Form II
 3. Cascade Form and
 4. Parallel Form



ELEMENTARY BLOCKS



Adder

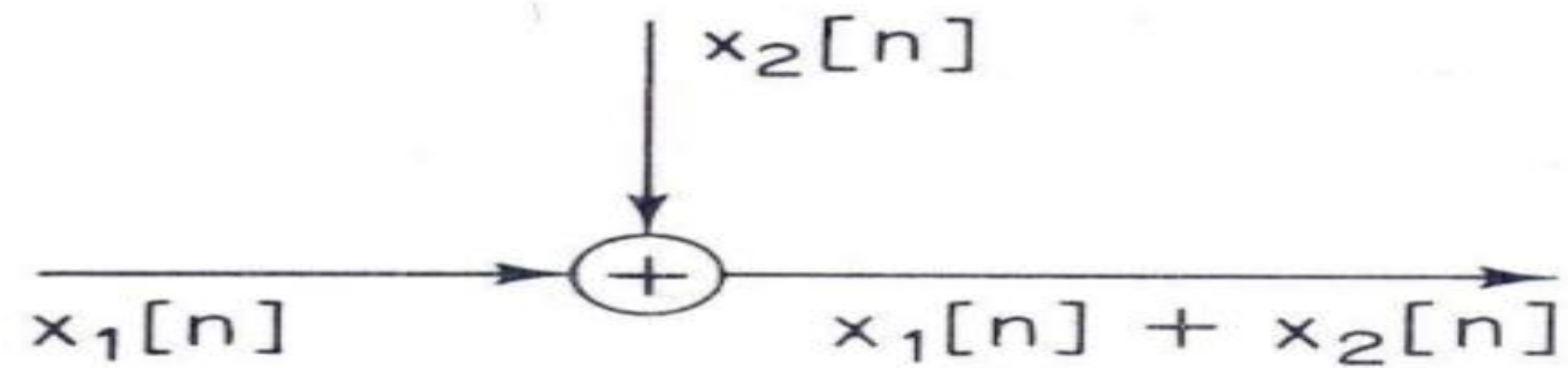

**Constant
Multiplier**

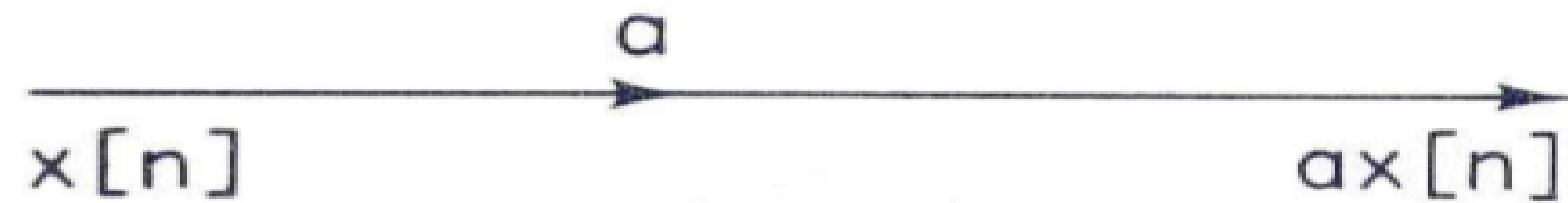

**Unit Delay
Element**

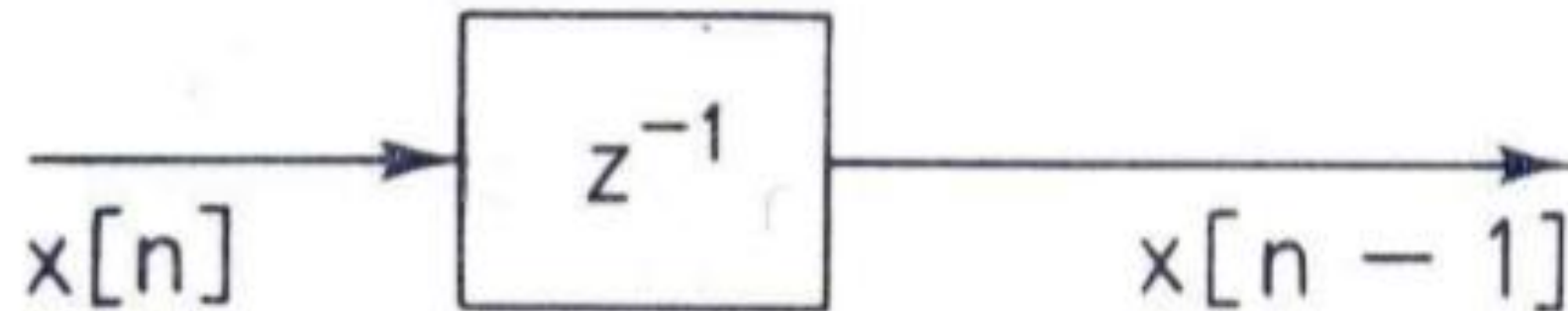



ELEMENTARY BLOCKS



**Signal
Multiplier**

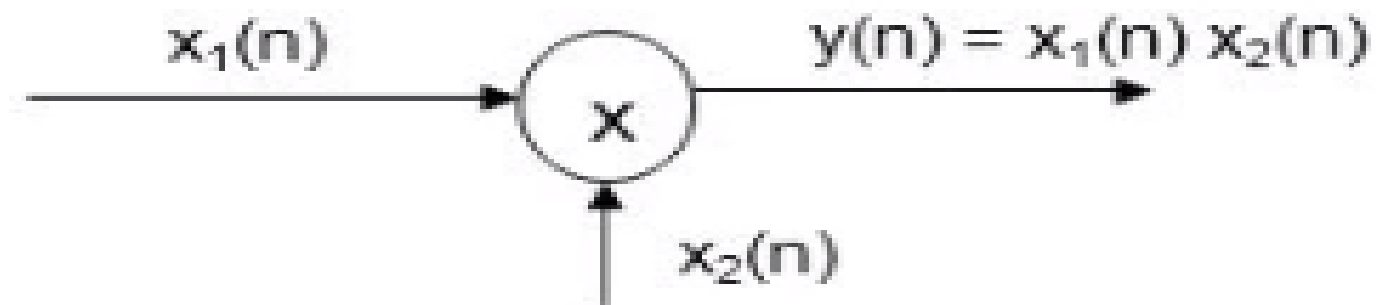

**Advancing
Element**

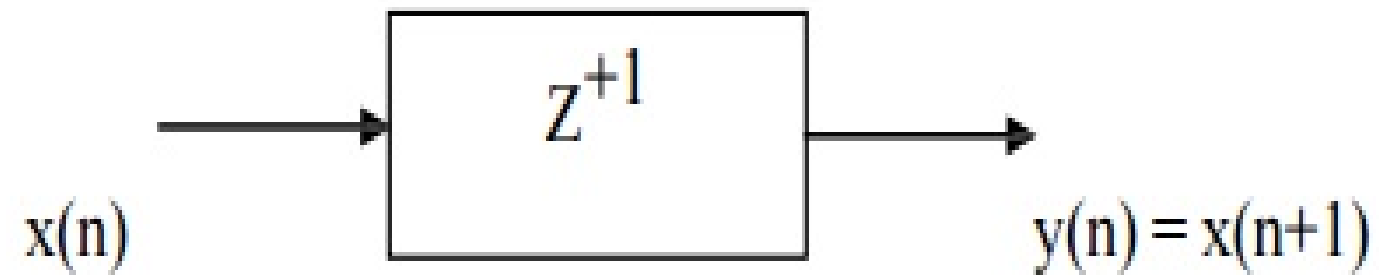

Multiplication

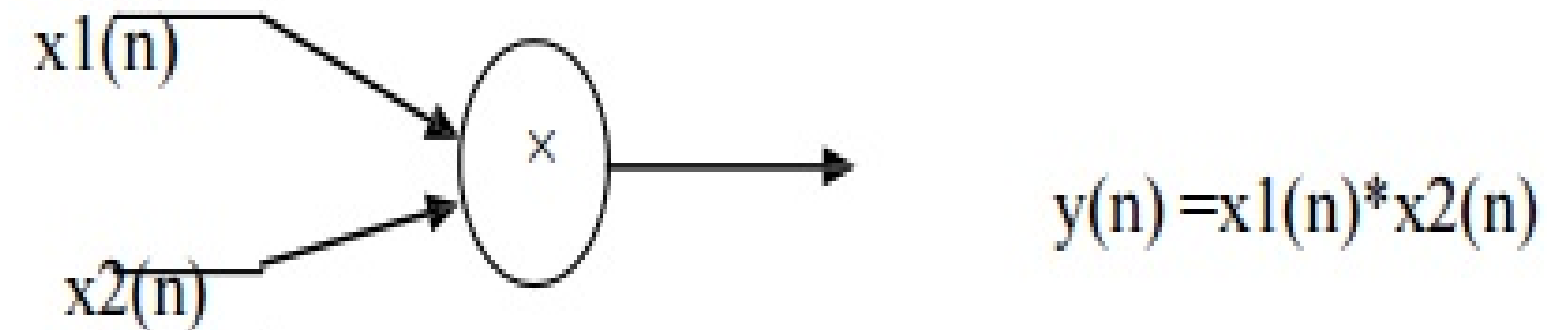



BLOCK DIAGRAM REPRESENTATION



$$y(n) = y(n-1) x(n-1) + 0.5 x(n)$$

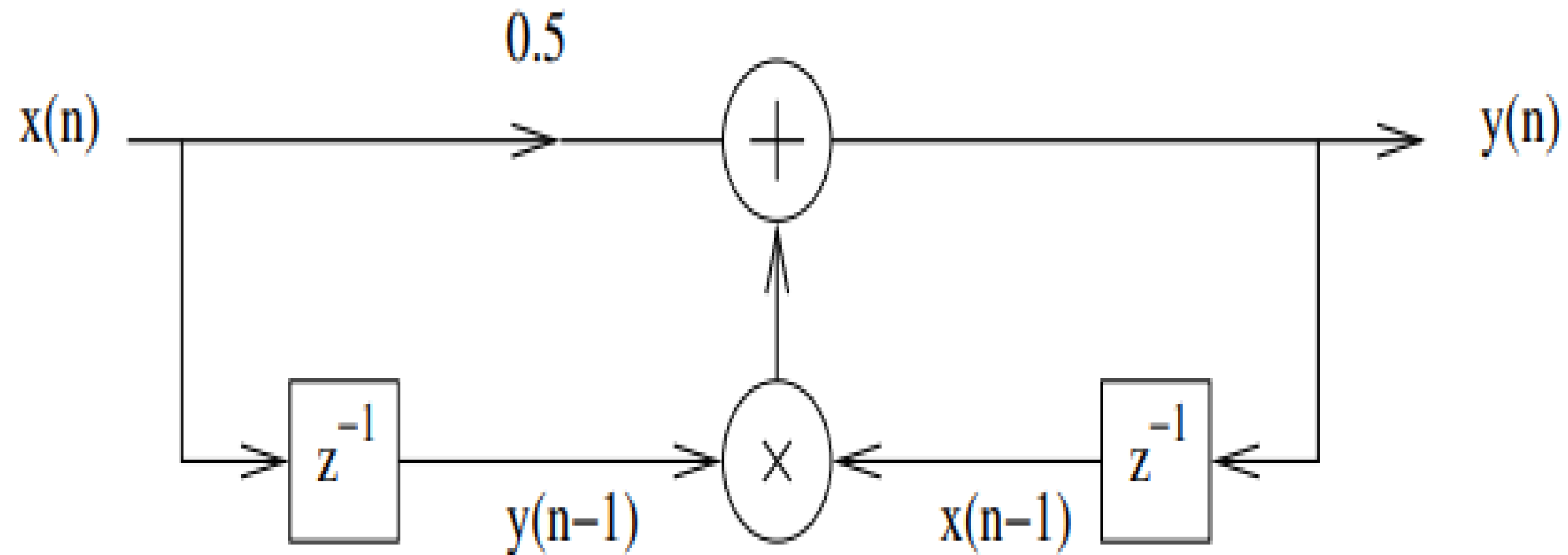



BLOCK DIAGRAM REPRESENTATION



$$H(z) = 1 / 1 - a z^{-1}$$

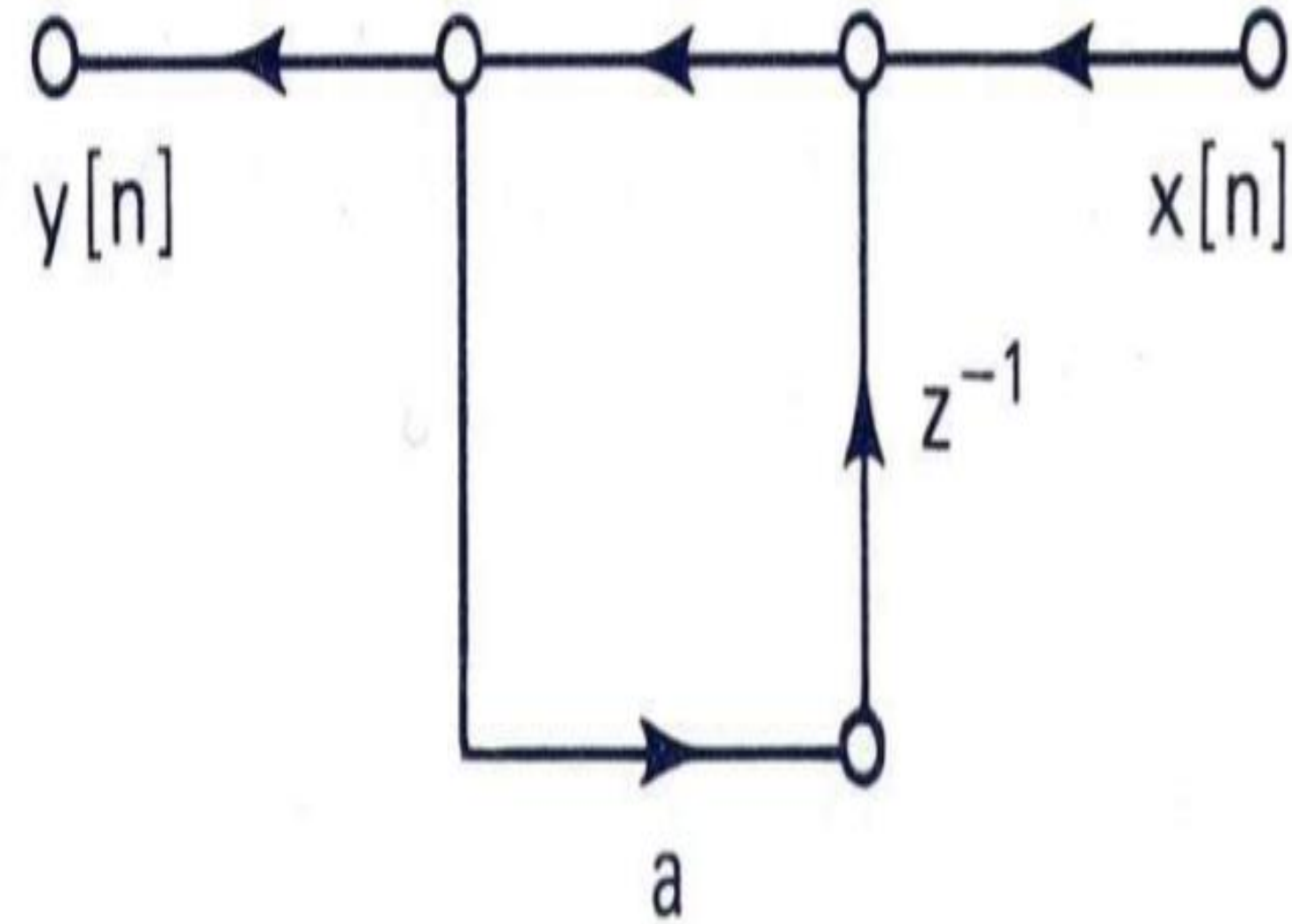
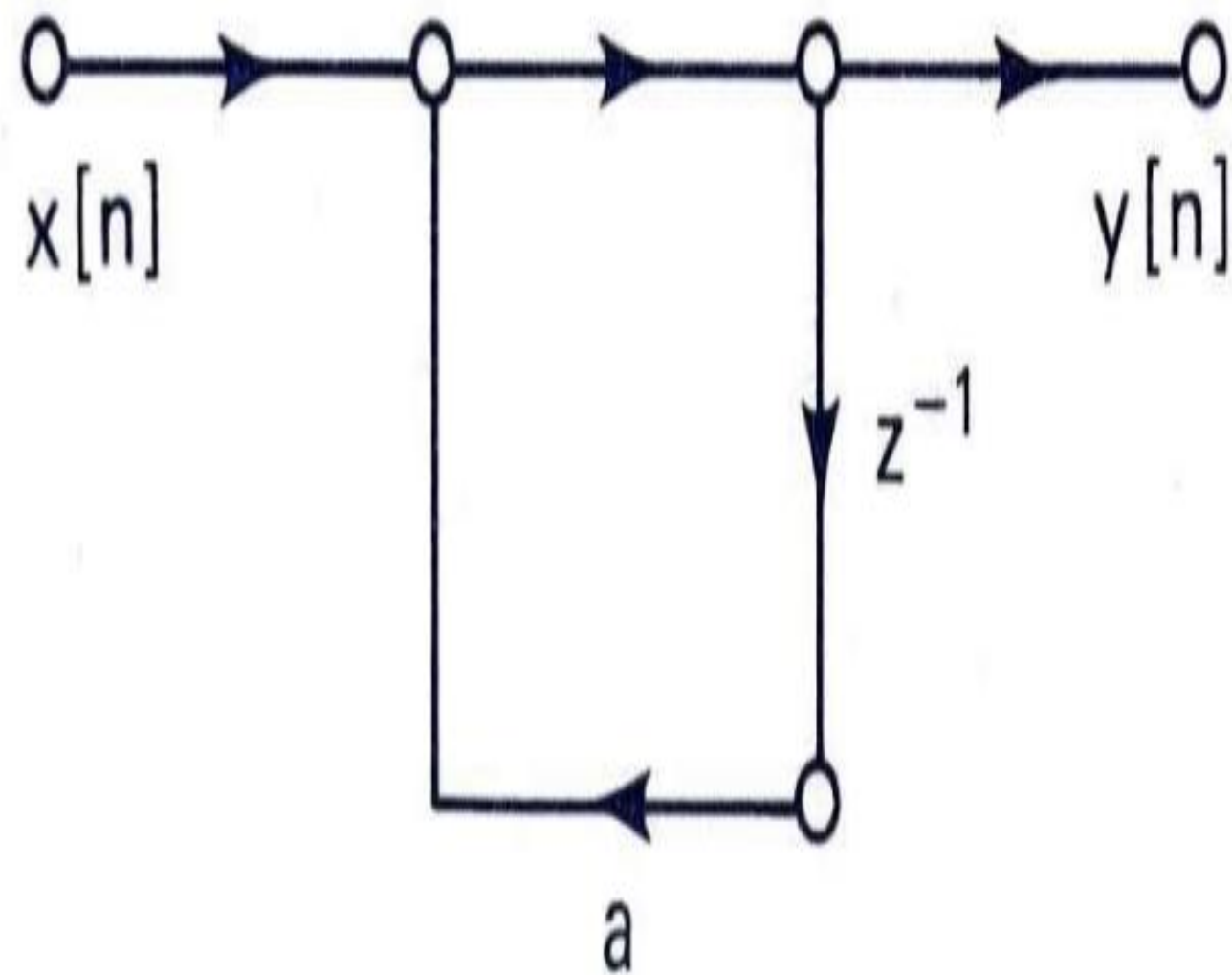



BLOCK DIAGRAM REPRESENTATION



$$y[n] = a_1y[n - 1] + a_2y[n - 2] + b_0x[n]$$

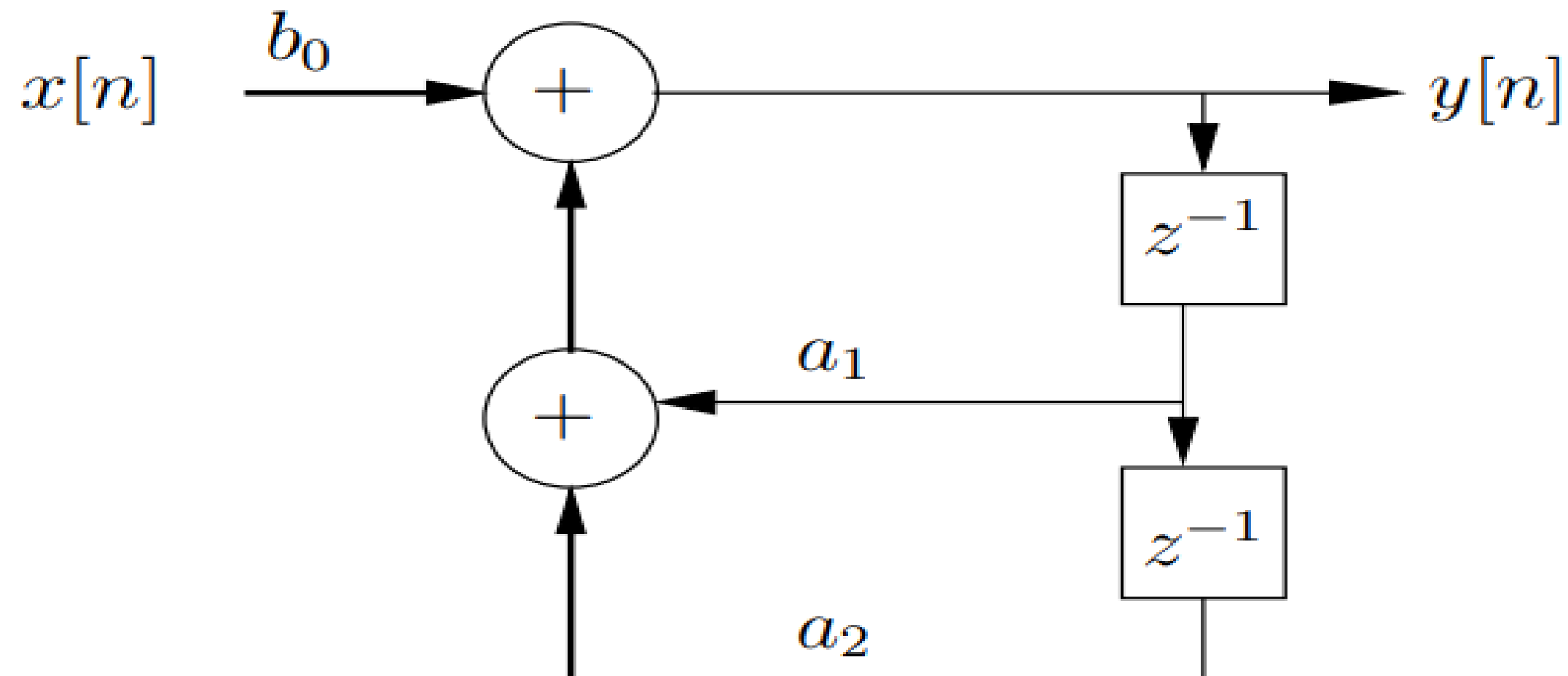



GENERAL DIRECT FORM I

$$H(z) = \frac{\sum_{k=0}^M b_k z^{-k}}{1 + \sum_{k=1}^N a_k z^{-k}}$$

$$H_1(z) = \sum_{k=0}^M b_k z^{-k}$$

$$H_2(z) = \frac{1}{1 + \sum_{k=1}^N a_k z^{-k}}$$

$$\therefore H(z) = H_1(z) \cdot H_2(z)$$

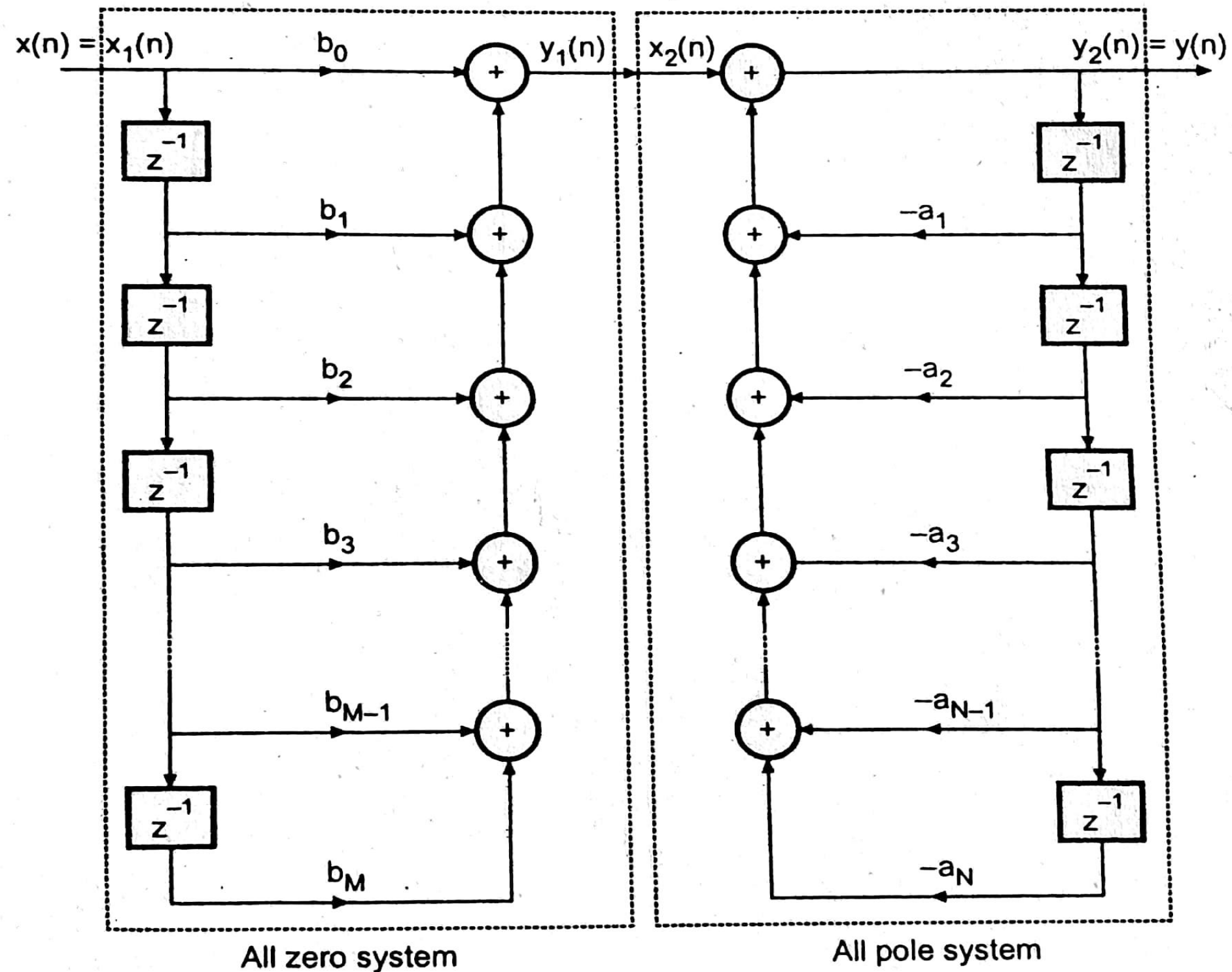



DIRECT FORM II



$$H(z) = \frac{\sum_{k=0}^{M-1} b_k z^{-k}}{1 + \sum_{k=1}^N a_k z^{-k}}$$

$$H(z) = \frac{Y(z)}{X(z)} \Rightarrow \frac{Y(z)}{W(z)} \cdot \frac{W(z)}{X(z)} \Rightarrow \frac{W(z)}{X(z)} \cdot \frac{Y(z)}{W(z)}$$

$$H_1(z) = \frac{W(z)}{X(z)} = \frac{1}{1 + \sum_{k=1}^N a_k z^{-k}}$$

$$H_2(z) = \frac{Y(z)}{W(z)} = \sum_{k=0}^{M-1} b_k z^{-k}$$



DIRECT FORM II

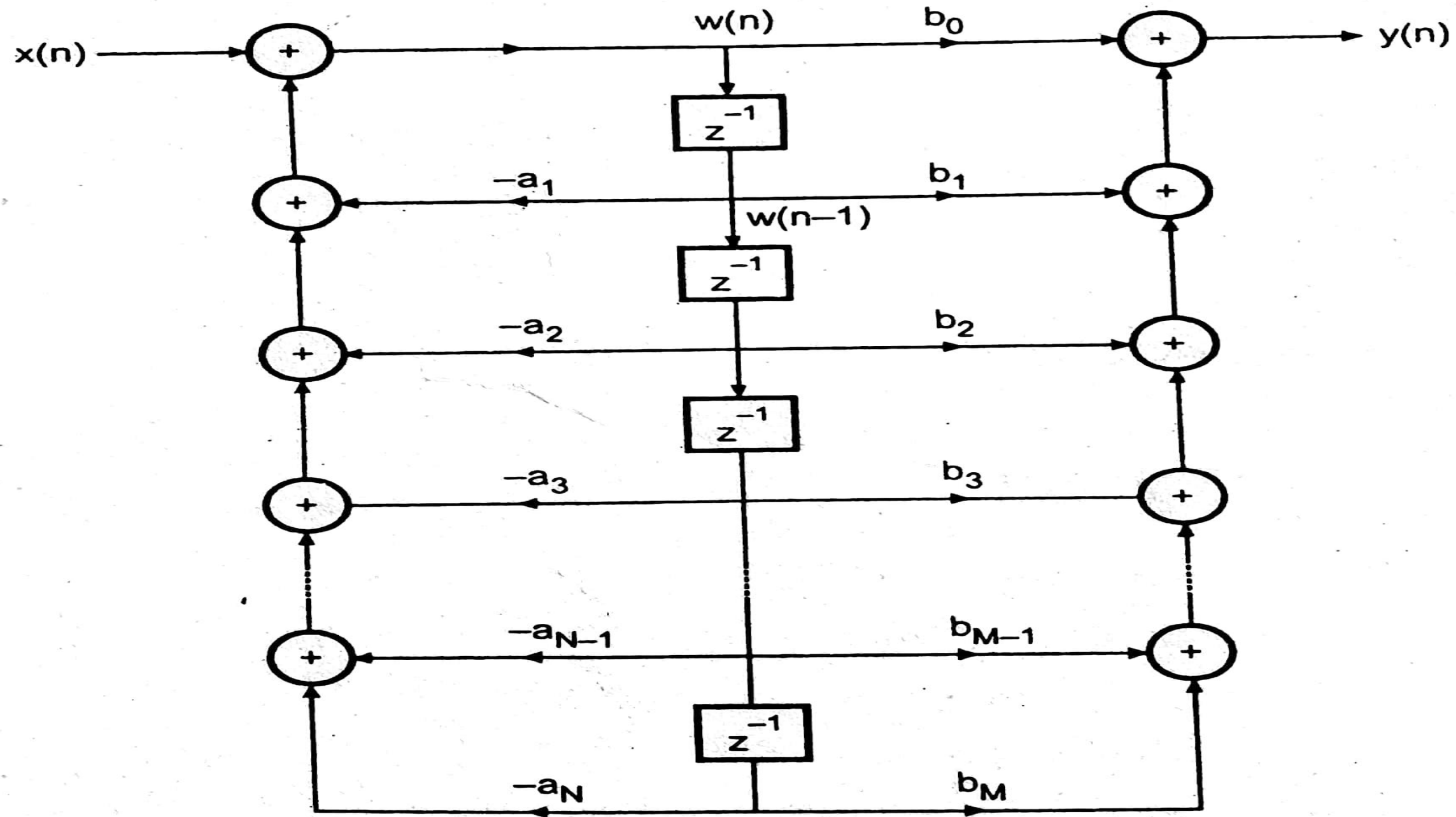



DIRECT FORM I



$$y(n] = \frac{3}{4} y[n-1] - \frac{1}{8} y[n-2] + x[n] + \frac{1}{2} x[n-1]$$

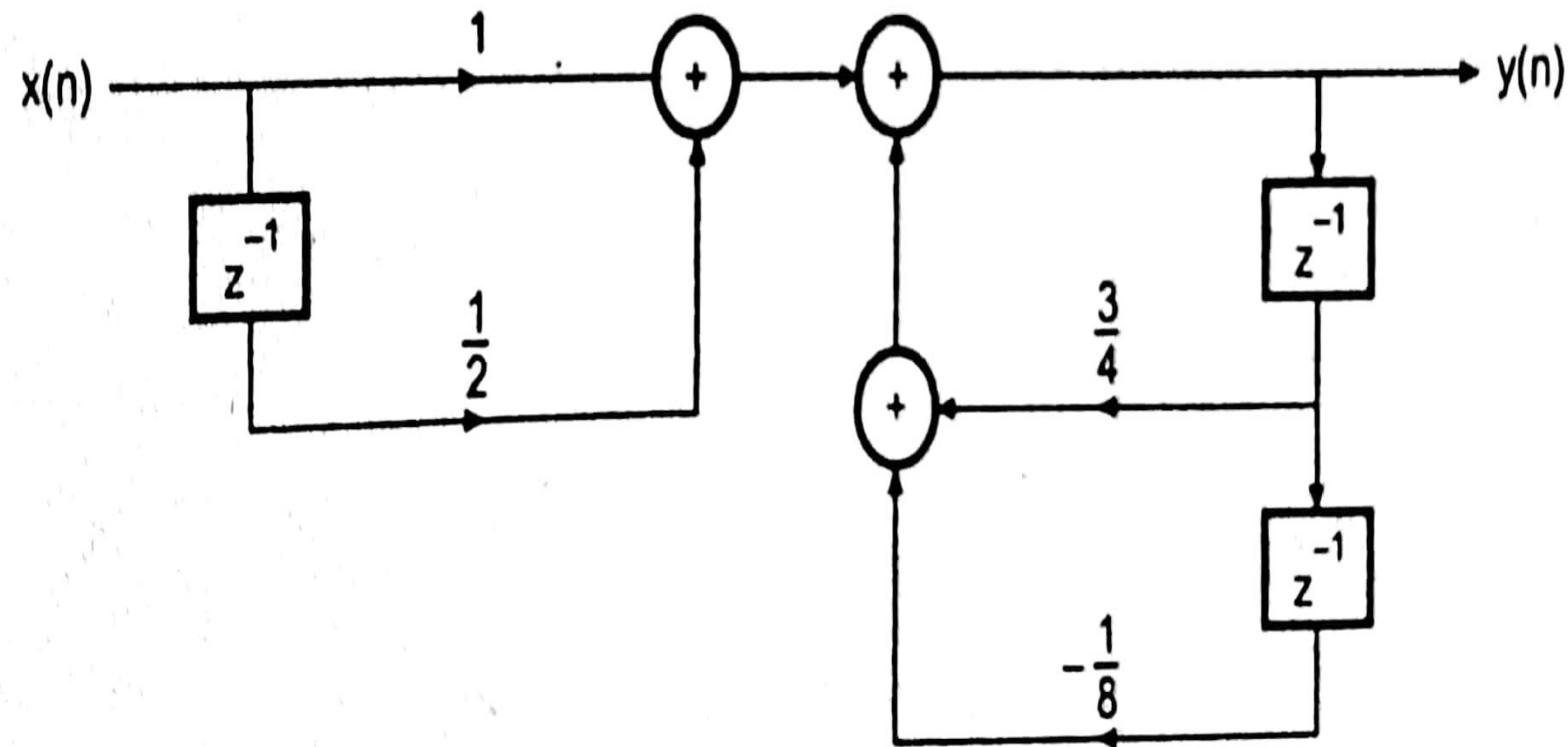



DIRECT FORM II



$$y(n] = \frac{3}{4} y[n-1] - \frac{1}{8} y[n-2] + x[n] + \frac{1}{2} x[n-1]$$

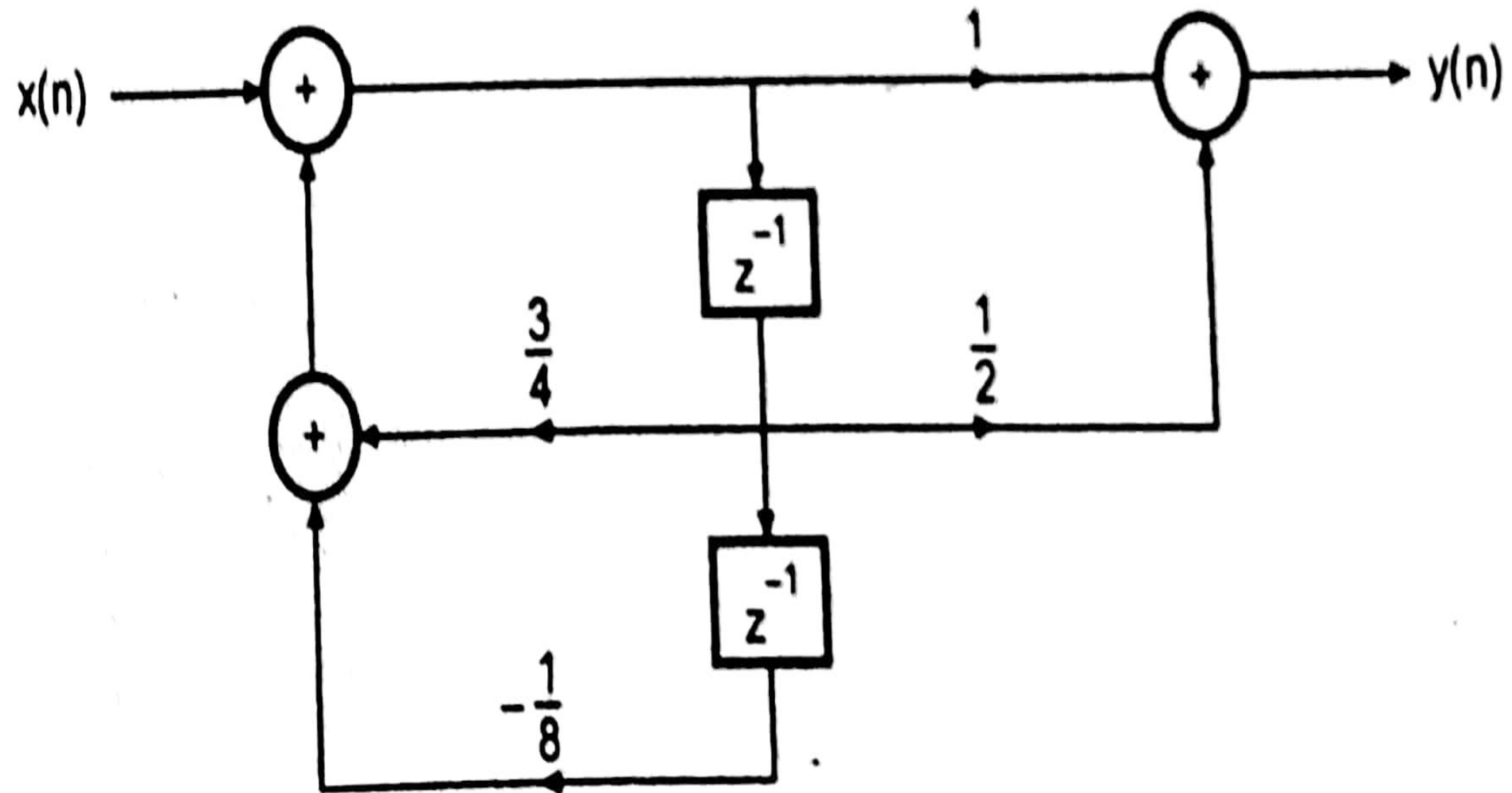



DIRECT FORM I & II



Consider System function : Direct form I & II

$$H(z) = \frac{1 + 2z^{-1} + z^{-2}}{1 - 0.75z^{-1} + 0.125z^{-2}}$$

$$H(z) = \frac{y(z)}{x(z)} = \frac{1 + 2z^{-1} + z^{-2}}{1 - 0.75z^{-1} + 0.125z^{-2}}$$

$$x(z) + 2z^{-1}x(z) + z^{-2}x(z) = y(z) - 0.75z^{-1}y(z) + 0.125z^{-2}y(z)$$

$$x(n) + 2x(n-1) + x(n-2) = y(n) - 0.75y(n-1) + 0.125y(n-2)$$

$$y(n) = x(n) + 2x(n-1) + x(n-2) + 0.75y(n-1) - 0.125y(n-2)$$



DIRECT FORM I

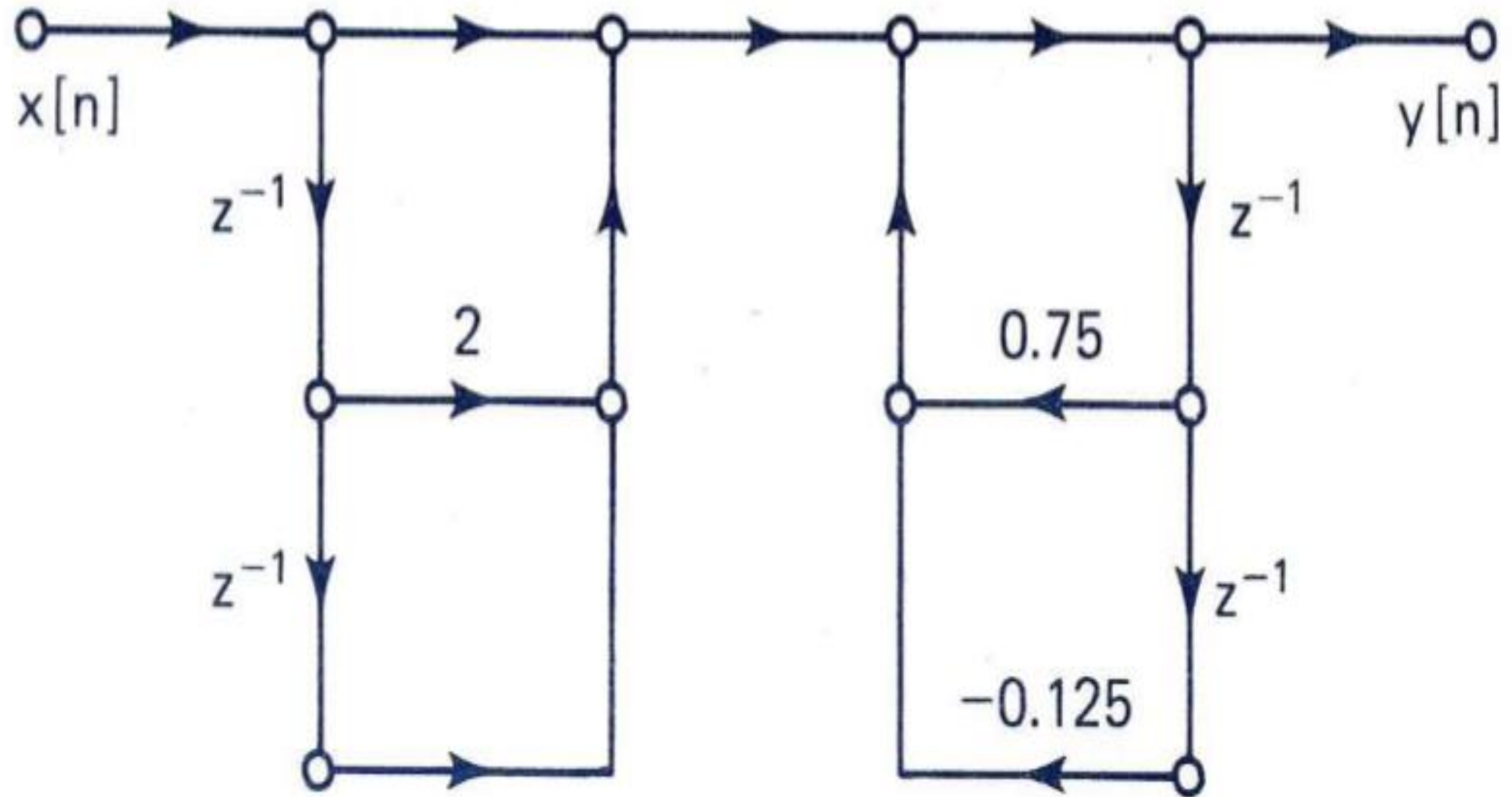



DIRECT FORM II

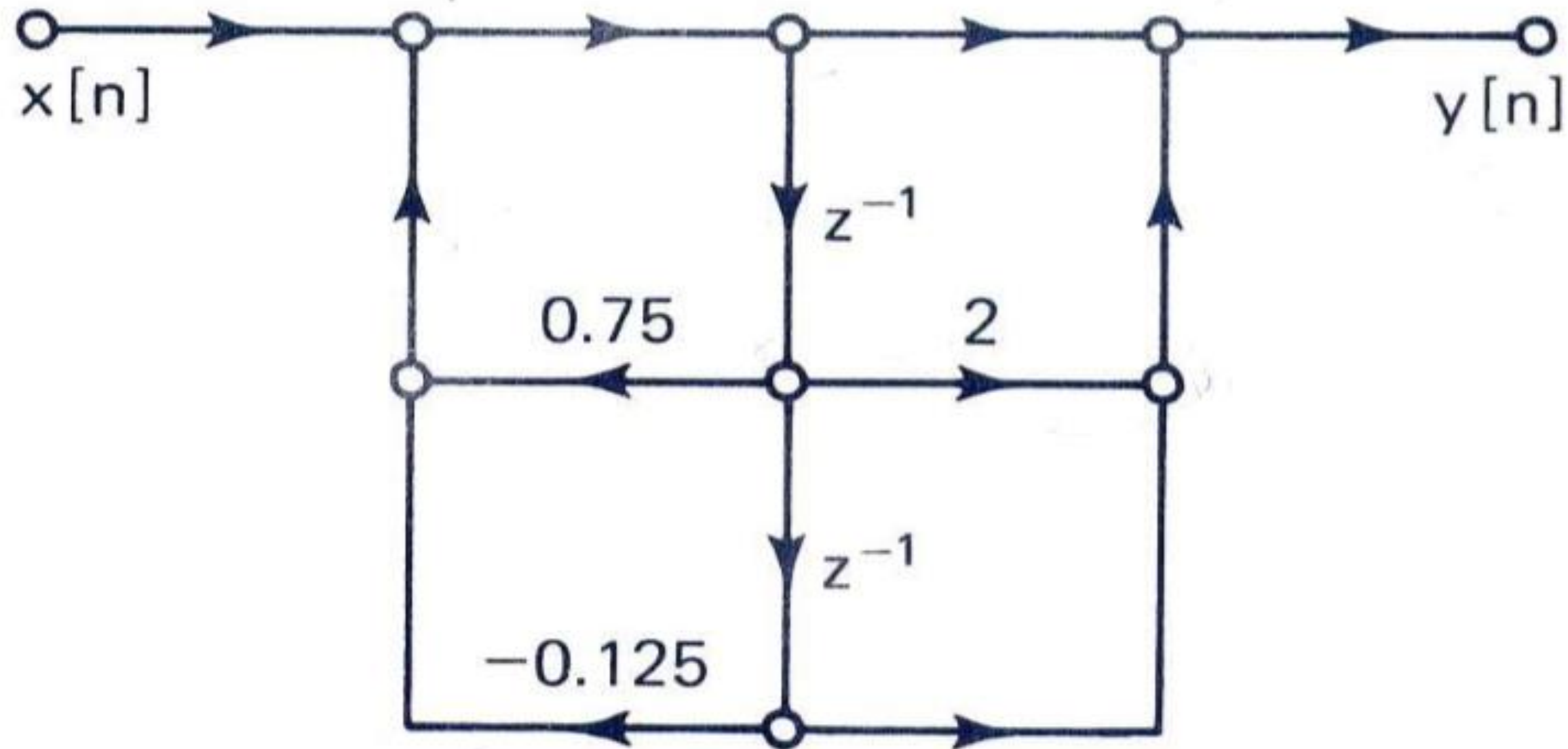



CASCADE & PARALLEL FORM



Cascade form :-

$$\begin{aligned} H(z) &= \frac{1 + 2z^{-1} + z^{-2}}{1 - 0.75z^{-1} + 0.125z^{-2}} \\ &= \frac{(1 + z^{-1})(1 + z^{-1})}{(1 - 0.5z^{-1})(1 - 0.25z^{-1})} \end{aligned}$$

Parallel form :-

$$\begin{aligned} H(z) &= \frac{1 + 2z^{-1} + z^{-2}}{1 - 0.75z^{-1} + 0.125z^{-2}} \\ &= 8 + \frac{-7 + 8z^{-1}}{1 - 0.75z^{-1} + 0.125z^{-2}} \\ &= 8 + \frac{18}{1 - 0.5z^{-1}} - \frac{25}{1 - 0.25z^{-1}} \end{aligned}$$



CASCADE FORM

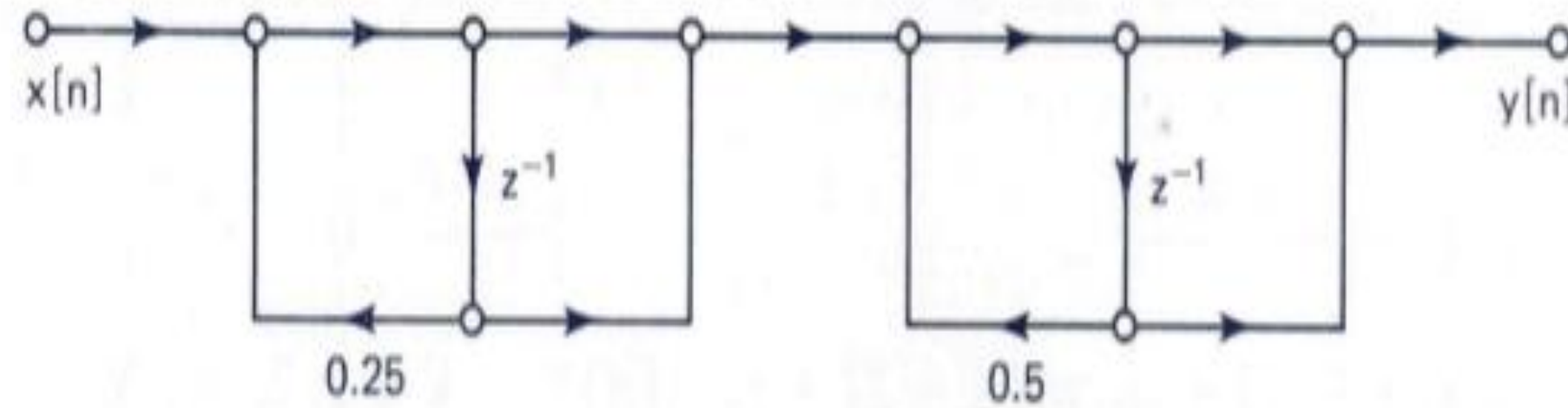
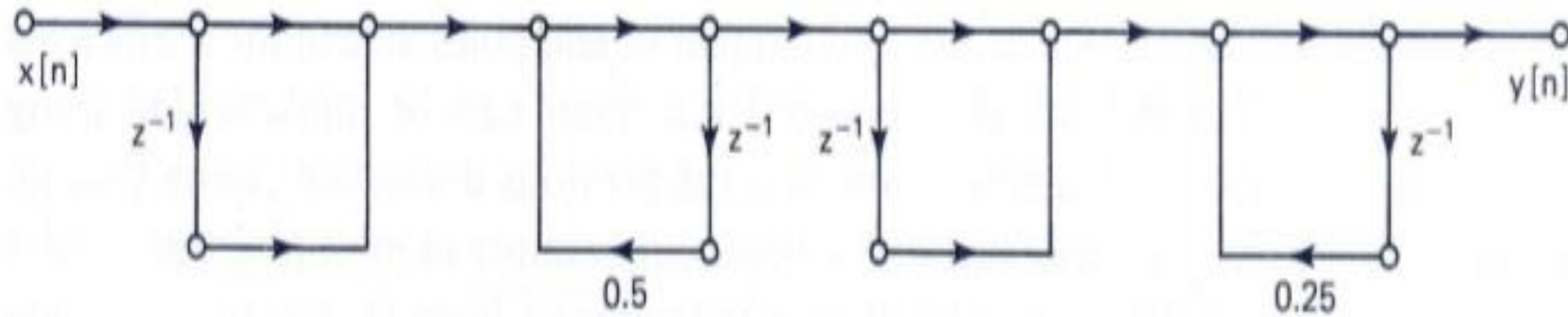



PARALLEL FORM

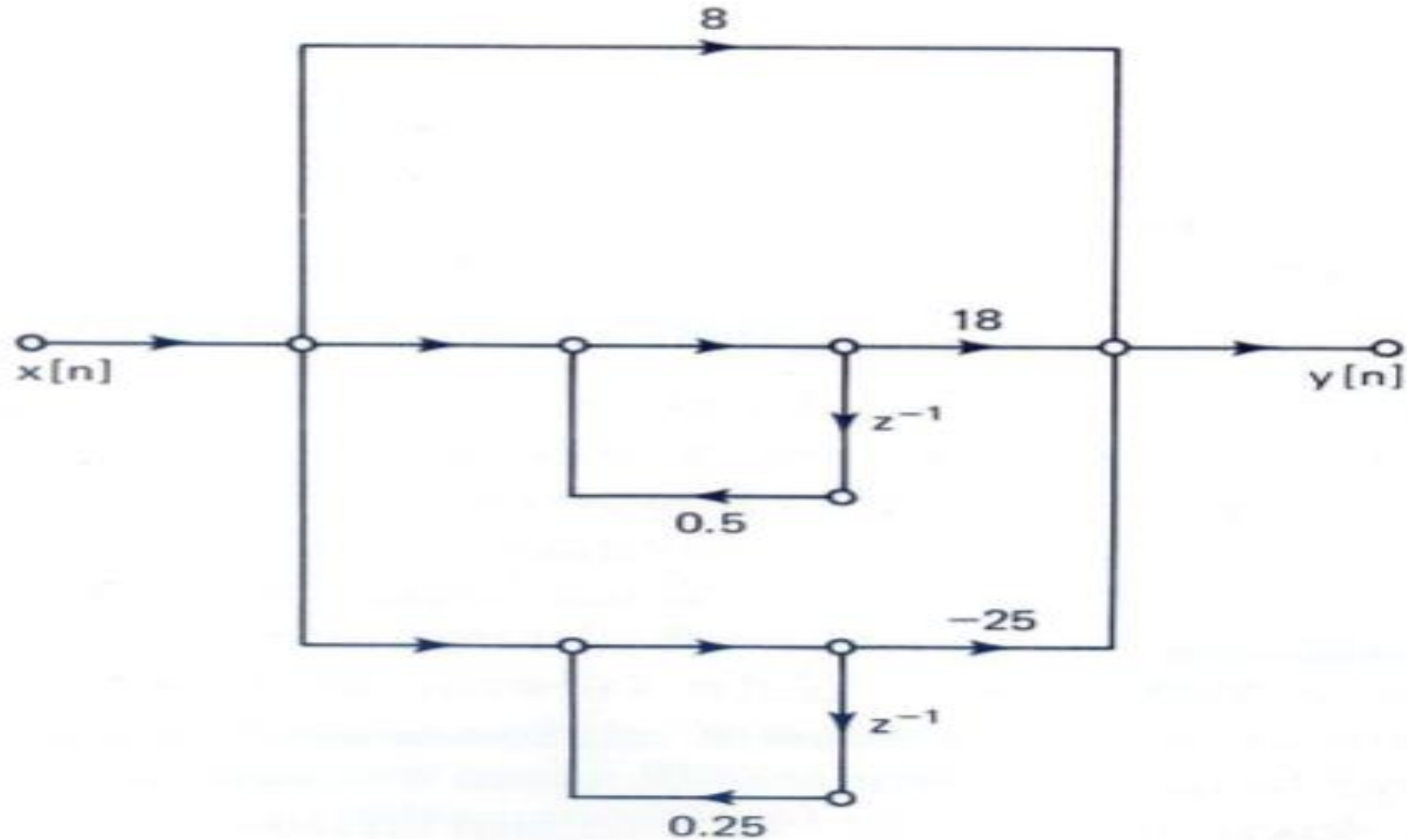



ASSESSMENT



1. Define block diagram.
2. Mention the structures to represent block diagram.
3. The system transfer function of LTI DT system is -----
4. List the summary of elementary blocks to represent discrete time systems.
5. Identify the difference equation:

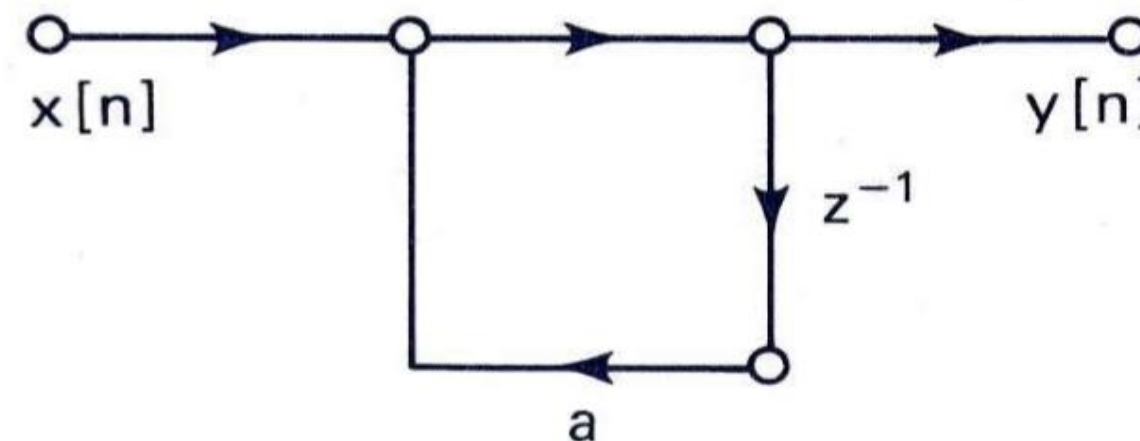



THANK YOU