



# **SNS COLLEGE OF TECHNOLOGY**

**Coimbatore-35**  
**An Autonomous Institution**



Accredited by NBA – AICTE and Accredited by NAAC – UGC with 'A+' Grade  
Approved by AICTE, New Delhi & Affiliated to Anna University, Chennai

## **DEPARTMENT OF AGRICULTURE ENGINEERING**

### **R2019-MACHINE DESIGN**

III YEAR V SEM

### **UNIT 2 –DESIGN OF FASTENERS**

TOPIC 5–Stresses in screwed fastening -Static loading-Due to external forces



## 11.6 Common Types of Screw Fastenings

Following are the common types of screw fastenings :

**1. Through bolts.** A through bolt (or simply a bolt) is shown in Fig. 11.12 (a). It is a cylindrical bar with threads for the nut at one end and head at the other end. The cylindrical part of the bolt is known as **shank**. It is passed through drilled holes in the two parts to be fastened together and clamped them securely to each other as the nut is screwed on to the threaded end. The through bolts may or may not have a machined finish and are made with either hexagonal or square heads. A through bolt should pass easily in the holes, when put under tension by a load along its axis. If the load acts perpendicular to the axis, tending to slide one of the connected parts along the other end thus subjecting it to shear, the holes should be reamed so that the bolt shank fits snugly there in. The through bolts according to their usage may be known as **machine bolts, carriage bolts, automobile bolts, eye bolts etc.**

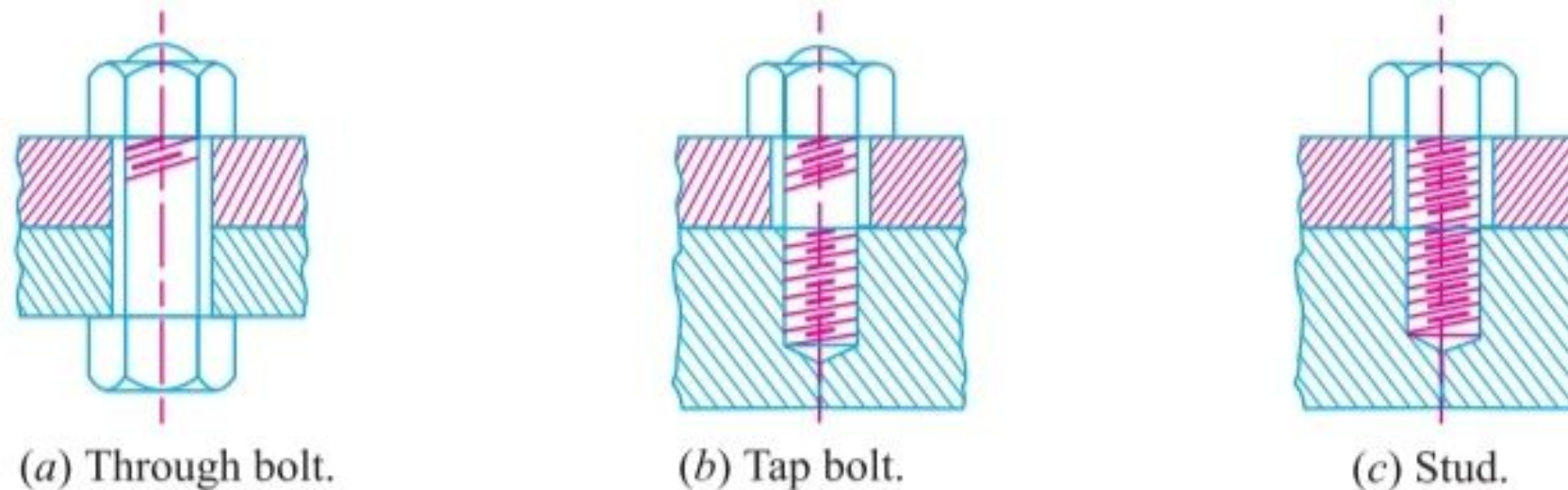

**Fig. 11.12**

**2. Tap bolts.** A tap bolt or screw differs from a bolt. It is screwed into a tapped hole of one of the parts to be fastened without the nut, as shown in Fig. 11.12 (b).

**3. Studs.** A stud is a round bar threaded at both ends. One end of the stud is screwed into a tapped hole of the parts to be fastened, while the other end receives a nut on it, as shown in Fig. 11.12 (c). Studs are chiefly used instead of tap bolts for securing various kinds of covers *e.g.* covers of engine and pump cylinders, valves, chests etc.



This is due to the fact that when tap bolts are unscrewed or replaced, they have a tendency to break the threads in the hole. This disadvantage is overcome by the use of studs.

**4. Cap screws.** The cap screws are similar to tap bolts except that they are of small size and a variety of shapes of heads are available as shown in Fig. 11.13.

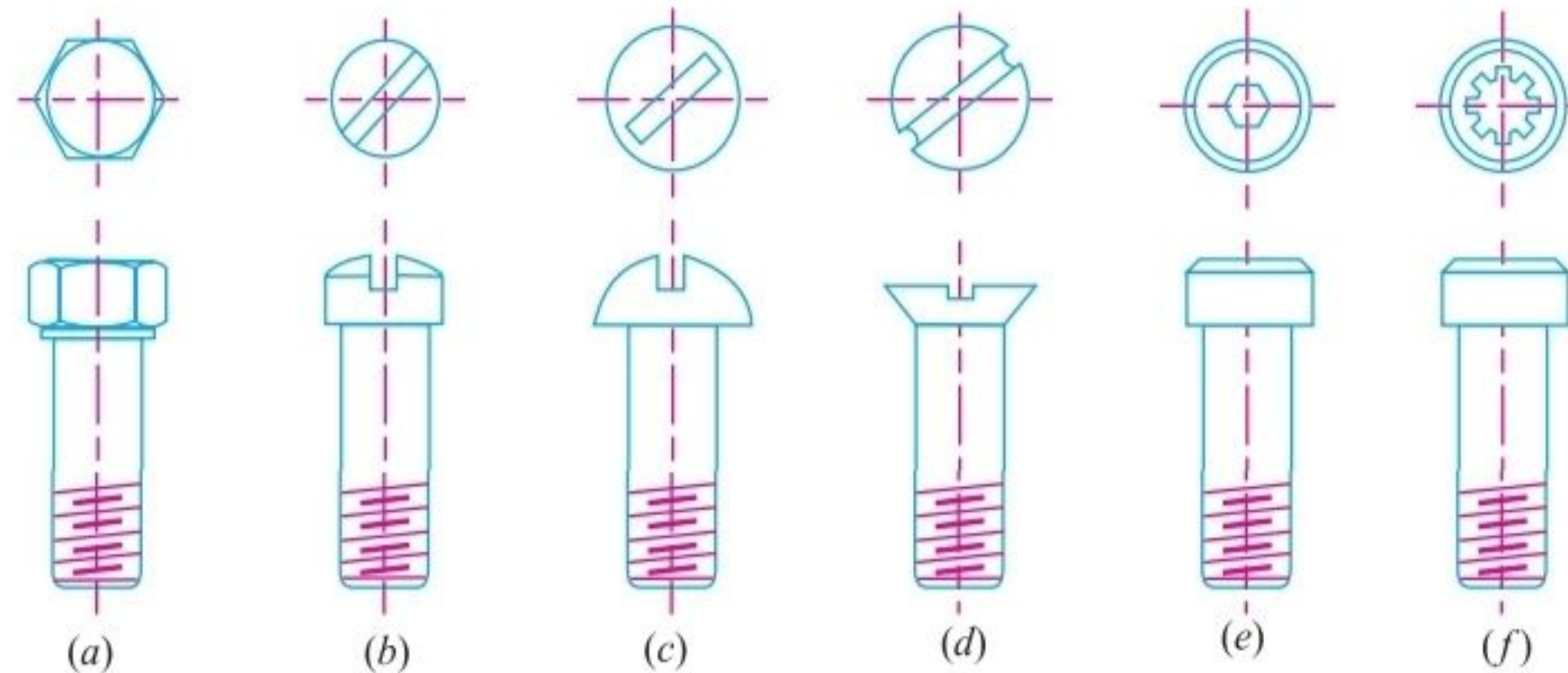

(a) Hexagonal head; (b) Fillister head; (c) Round head; (d) Flat head; (e) Hexagonal socket; (f) Fluted socket.

**Fig. 11.13.** Types of cap screws.

**5. Machine screws.** These are similar to cap screws with the head slotted for a screw driver. These are generally used with a nut.



**6. Set screws.** The set screws are shown in Fig. 11.14. These are used to prevent relative motion between the two parts. A set screw is screwed through a threaded hole in one part so that its point (*i.e.* end of the screw) presses against the other part. This resists the relative motion between the two parts by means of friction between the point of the screw and one of the parts. They may be used instead of key to prevent relative motion between a hub and a shaft in light power transmission members. They may also be used in connection with a key, where they prevent relative axial motion of the shaft, key and hub assembly.

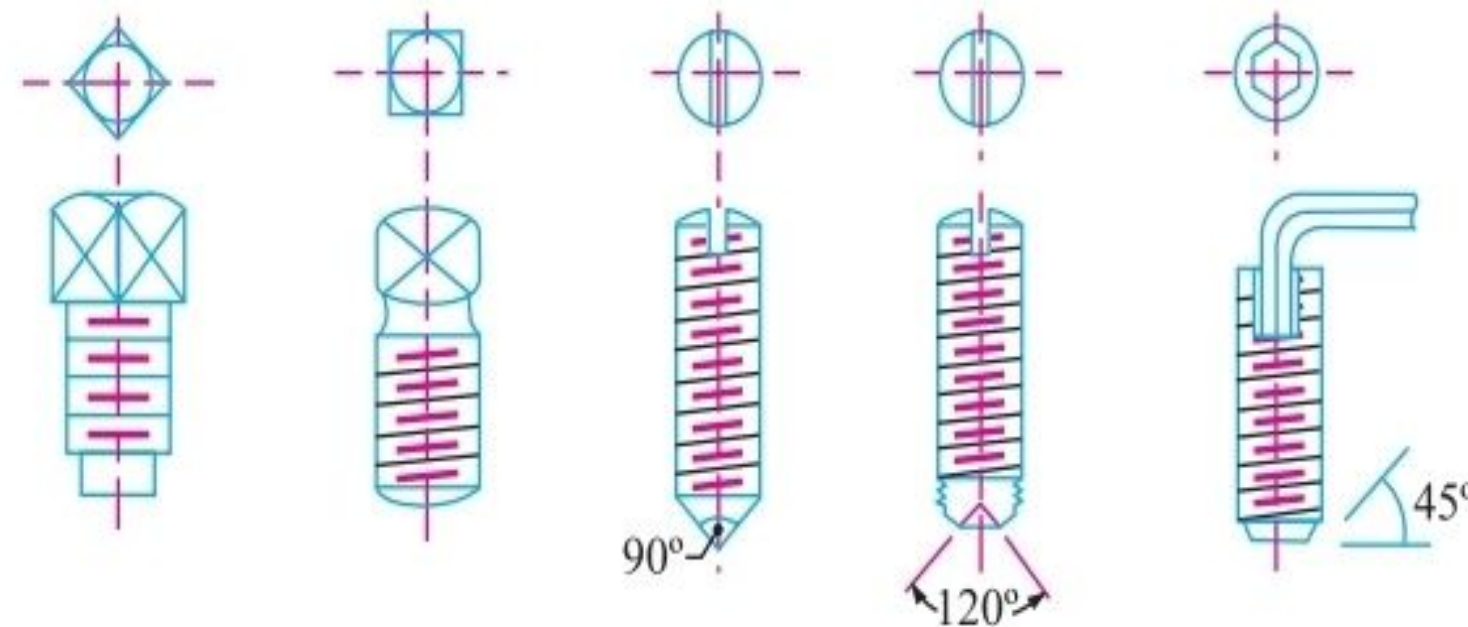

**Fig. 11.14.** Set screws.

The diameter of the set screw ( $d$ ) may be obtained from the following expression:

$$d = 0.125 D + 8 \text{ mm}$$

where  $D$  is the diameter of the shaft (in mm) on which the set screw is pressed.

The tangential force (in newtons) at the surface of the shaft is given by

$$F = 6.6 (d)^{2.3}$$



## 11.9 Standard Dimensions of Screw Threads

The design dimensions of I.S.O. screw threads for screws, bolts and nuts of coarse and fine series are shown in Table 11.1.

**Table 11.1. Design dimensions of screw threads, bolts and nuts according to IS : 4218 (Part III) 1976 (Reaffirmed 1996) (Refer Fig. 11.1)**

Designation	Pitch mm	Major or nominal diameter Nut and Bolt ( $d = D$ ) mm	Effective or pitch diameter Nut and Bolt ( $d_p$ ) mm	Minor or core diameter ( $d_c$ ) mm		Depth of thread (bolt) mm	Stress area mm <sup>2</sup>
				Bolt	Nut		
(1)	(2)	(3)	(4)	(5)	(6)	(7)	(8)
<b>Coarse series</b>							
M 0.4	0.1	0.400	0.335	0.277	0.292	0.061	0.074
M 0.6	0.15	0.600	0.503	0.416	0.438	0.092	0.166
M 0.8	0.2	0.800	0.670	0.555	0.584	0.123	0.295
M 1	0.25	1.000	0.838	0.693	0.729	0.153	0.460
M 1.2	0.25	1.200	1.038	0.893	0.929	0.158	0.732
M 1.4	0.3	1.400	1.205	1.032	1.075	0.184	0.983
M 1.6	0.35	1.600	1.373	1.171	1.221	0.215	1.27
M 1.8	0.35	1.800	1.573	1.371	1.421	0.215	1.70
M 2	0.4	2.000	1.740	1.509	1.567	0.245	2.07
M 2.2	0.45	2.200	1.908	1.648	1.713	0.276	2.48
M 2.5	0.45	2.500	2.208	1.948	2.013	0.276	3.39



M 30	3.5	30.000	27.727	25.706	26.211	2.147	561
M 33	3.5	33.000	30.727	28.706	29.211	2.147	694
M 36	4	36.000	33.402	31.093	31.670	2.454	817
M 39	4	39.000	36.402	34.093	34.670	2.454	976
M 42	4.5	42.000	39.077	36.416	37.129	2.760	1104
M 45	4.5	45.000	42.077	39.416	40.129	2.760	1300
M 48	5	48.000	44.752	41.795	42.587	3.067	1465
M 52	5	52.000	48.752	45.795	46.587	3.067	1755
M 56	5.5	56.000	52.428	49.177	50.046	3.067	2022
M 60	5.5	60.000	56.428	53.177	54.046	3.374	2360
<b>Fine series</b>							
M 8 × 1	1	8.000	7.350	6.773	6.918	0.613	39.2
M 10 × 1.25	1.25	10.000	9.188	8.466	8.647	0.767	61.6
M 12 × 1.25	1.25	12.000	11.184	10.466	10.647	0.767	92.1
M 14 × 1.5	1.5	14.000	13.026	12.160	12.376	0.920	125
M 16 × 1.5	1.5	16.000	15.026	14.160	14.376	0.920	167
M 18 × 1.5	1.5	18.000	17.026	16.160	16.376	0.920	216
M 20 × 1.5	1.5	20.000	19.026	18.160	18.376	0.920	272
M 22 × 1.5	1.5	22.000	21.026	20.160	20.376	0.920	333
M 24 × 2	2	24.000	22.701	21.546	21.835	1.227	384
M 27 × 2	2	27.000	25.701	24.546	24.835	1.227	496
M 30 × 2	2	30.000	28.701	27.546	27.835	1.227	621
M 33 × 2	2	33.000	31.701	30.546	30.835	1.227	761
M 36 × 3	3	36.000	34.051	32.319	32.752	1.840	865
M 39 × 3	3	39.000	37.051	35.319	35.752	1.840	1028



## 11.12 Stresses due to External Forces

The following stresses are induced in a bolt when it is subjected to an external load.

**1. Tensile stress.** The bolts, studs and screws usually carry a load in the direction of the bolt axis which induces a tensile stress in the bolt.

Let  $d_c$  = Root or core diameter of the thread, and  
 $\sigma_t$  = Permissible tensile stress for the bolt material.

We know that external load applied,

$$P = \frac{\pi}{4} (d_c)^2 \sigma_t \quad \text{or} \quad d_c = \sqrt{\frac{4P}{\pi \sigma_t}}$$

Now from Table 11.1, the value of the nominal diameter of bolt corresponding to the value of  $d_c$

may be obtained or stress area  $\left[ \frac{\pi}{4} (d_c)^2 \right]$  may be fixed.

**Notes:** (a) If the external load is taken up by a number of bolts, then

$$P = \frac{\pi}{4} (d_c)^2 \sigma_t \times n$$

(b) In case the standard table is not available, then for coarse threads,  $d_c = 0.84 d$ , where  $d$  is the nominal diameter of bolt.



**2. Shear stress.** Sometimes, the bolts are used to prevent the relative movement of two or more parts, as in case of flange coupling, then the shear stress is induced in the bolts. The shear stresses should be avoided as far as possible. It should be noted that when the bolts are subjected to direct shearing loads, they should be located in such a way that the shearing load comes upon the body (*i.e.* shank) of the bolt and not upon the threaded portion. In some cases, the bolts may be relieved of shear load by using shear pins. When a number of bolts are used to share the shearing load, the finished bolts should be fitted to the reamed holes.

Let  $d$  = Major diameter of the bolt, and  
 $n$  = Number of bolts.

∴ Shearing load carried by the bolts,

$$P_s = \frac{\pi}{4} \times d^2 \times \tau \times n \quad \text{or} \quad d = \sqrt{\frac{4 P_s}{\pi \tau n}}$$

**3. Combined tension and shear stress.** When the bolt is subjected to both tension and shear loads, as in case of coupling bolts or bearing, then the diameter of the shank of the bolt is obtained from the shear load and that of threaded part from the tensile load. A diameter slightly larger than that required for either shear or tension may be assumed and stresses due to combined load should be checked for the following principal stresses.

Maximum principal shear stress,

$$\tau_{max} = \frac{1}{2} \sqrt{(\sigma_t)^2 + 4\tau^2}$$

and maximum principal tensile stress,





$$\sigma_{t(max)} = \frac{\sigma_t}{2} + \frac{1}{2} \sqrt{(\sigma_t)^2 + 4\tau^2}$$

These stresses should not exceed the safe permissible values of stresses.

**Example 11.3.** An eye bolt is to be used for lifting a load of 60 kN. Find the nominal diameter of the bolt, if the tensile stress is not to exceed 100 MPa. Assume coarse threads.

**Solution.** Given :  $P = 60 \text{ kN} = 60 \times 10^3 \text{ N}$  ;  
 $\sigma_t = 100 \text{ MPa} = 100 \text{ N/mm}^2$

An eye bolt for lifting a load is shown in Fig. 11.22.

Let  $d$  = Nominal diameter of the bolt, and

$d_c$  = Core diameter of the bolt.

We know that load on the bolt ( $P$ ),

$$60 \times 10^3 = \frac{\pi}{4} (d_c)^2 \sigma_t = \frac{\pi}{4} (d_c)^2 100 = 78.55 (d_c)^2$$

$$\therefore (d_c)^2 = 600 \times 10^3 / 78.55 = 764 \text{ or } d_c = 27.6 \text{ mm}$$

From Table 11.1 (coarse series), we find that the standard core diameter ( $d_c$ ) is 28.706 mm and the corresponding nominal diameter ( $d$ ) is 33 mm. **Ans.**

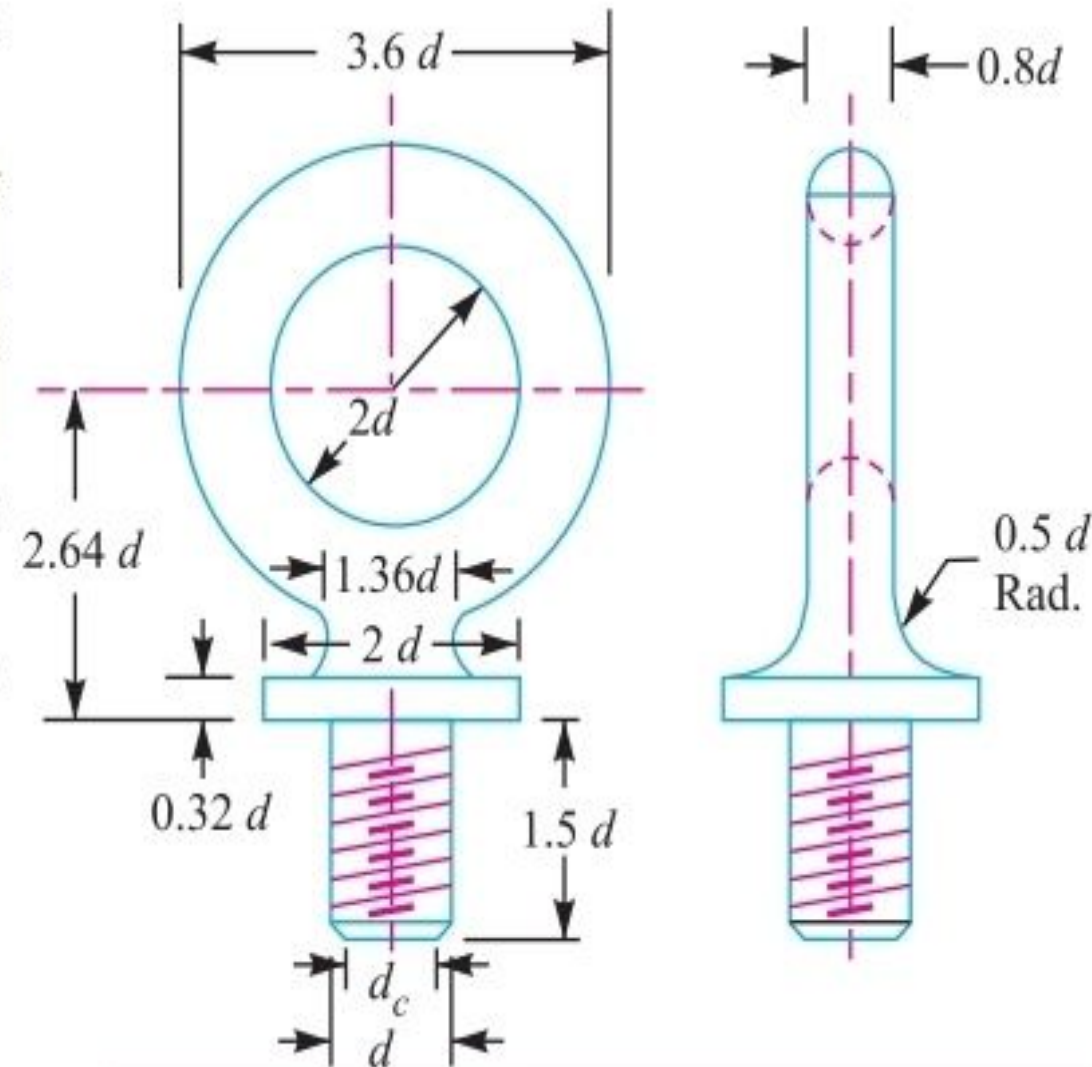

Fig. 11.22



**Note :** A lifting eye bolt, as shown in Fig. 11.22, is used for lifting and transporting heavy machines. It consists of a ring of circular cross-section at the head and provided with threads at the lower portion for screwing inside a threaded hole on the top of the machine.

**Example 11.4.** Two shafts are connected by means of a flange coupling to transmit torque of 25 N-m. The flanges of the coupling are fastened by four bolts of the same material at a radius of 30 mm. Find the size of the bolts if the allowable shear stress for the bolt material is 30 MPa.

**Solution.** Given :  $T = 25 \text{ N-m} = 25 \times 10^3 \text{ N-mm}$  ;  $n = 4$  ;  $R_p = 30 \text{ mm}$  ;  $\tau = 30 \text{ MPa} = 30 \text{ N/mm}^2$

We know that the shearing load carried by flange coupling,

$$P_s = \frac{T}{R_p} = \frac{25 \times 10^3}{30} = 833.3 \text{ N} \quad \dots(i)$$

Let  $d_c$  = Core diameter of the bolt.

$\therefore$  Resisting load on the bolts

$$= \frac{\pi}{4} (d_c)^2 \tau \times n = \frac{\pi}{4} (d_c)^2 30 \times 4 = 94.26 (d_c)^2 \quad \dots(ii)$$

From equations (i) and (ii), we get

$$(d_c)^2 = 833.3 / 94.26 = 8.84 \quad \text{or} \quad d_c = 2.97 \text{ mm}$$

From Table 11.1 (coarse series), we find that the standard core diameter of the bolt is 3.141 mm and the corresponding size of the bolt is M 4. **Ans.**



**Example 11.5.** A lever loaded safety valve has a diameter of 100 mm and the blow off pressure is  $1.6 \text{ N/mm}^2$ . The fulcrum of the lever is screwed into the cast iron body of the cover. Find the diameter of the threaded part of the fulcrum if the permissible tensile stress is limited to 50 MPa and the leverage ratio is 8.

**Solution.** Given :  $D = 100 \text{ mm}$  ;  $p = 1.6 \text{ N/mm}^2$ ;  $\sigma_t = 50 \text{ MPa} = 50 \text{ N/mm}^2$

We know that the load acting on the valve,

$$F = \text{Area} \times \text{pressure} = \frac{\pi}{4} \times D^2 \times p = \frac{\pi}{4} (100)^2 1.6 = 12\,568 \text{ N}$$

Since the leverage is 8, therefore load at the end of the lever,

$$W = \frac{12\,568}{8} = 1571 \text{ N}$$

$\therefore$  Load on the fulcrum,

$$P = F - W = 12\,568 - 1571 = 10\,997 \text{ N} \quad \dots(i)$$

Let

$d_c =$  Core diameter of the threaded part.

$\therefore$  Resisting load on the threaded part of the fulcrum,

$$P = \frac{\pi}{4} (d_c)^2 \sigma_t = \frac{\pi}{4} (d_c)^2 50 = 39.3 (d_c)^2 \quad \dots(ii)$$

From equations (i) and (ii), we get

$$(d_c)^2 = 10\,997 / 39.3 = 280 \quad \text{or} \quad d_c = 16.7 \text{ mm}$$

From Table 11.1 (fine series), we find that the standard core diameter is 18.376 mm and the corresponding size of the bolt is M 20  $\times$  1.5. **Ans.**



*Thank You*