



SNS COLLEGE OF TECHNOLOGY

Coimbatore-35
An Autonomous Institution



Accredited by NBA – AICTE and Accredited by NAAC – UGC with 'A++' Grade
Approved by AICTE, New Delhi & Affiliated to Anna University, Chennai

DEPARTMENT OF ELECTRONICS & COMMUNICATION ENGINEERING

19ECT312 – EMBEDDED SYSTEM DESIGN

III YEAR/ VI SEMESTER

UNIT 1 – INTRODUCTION TO EMBEDDED SYSTEMS

TOPIC 2 –1.4 System design using general purpose processor

1/21/2024



SYSTEM DESIGN USING GENERAL PURPOSE PROCESSOR



General-purpose processors are **the target processors that probably first come to mind to anyone writing a computer program.**

GPPs are the processors that power desktop computers and are at the centre of the computer revolution that began in the 1970s.

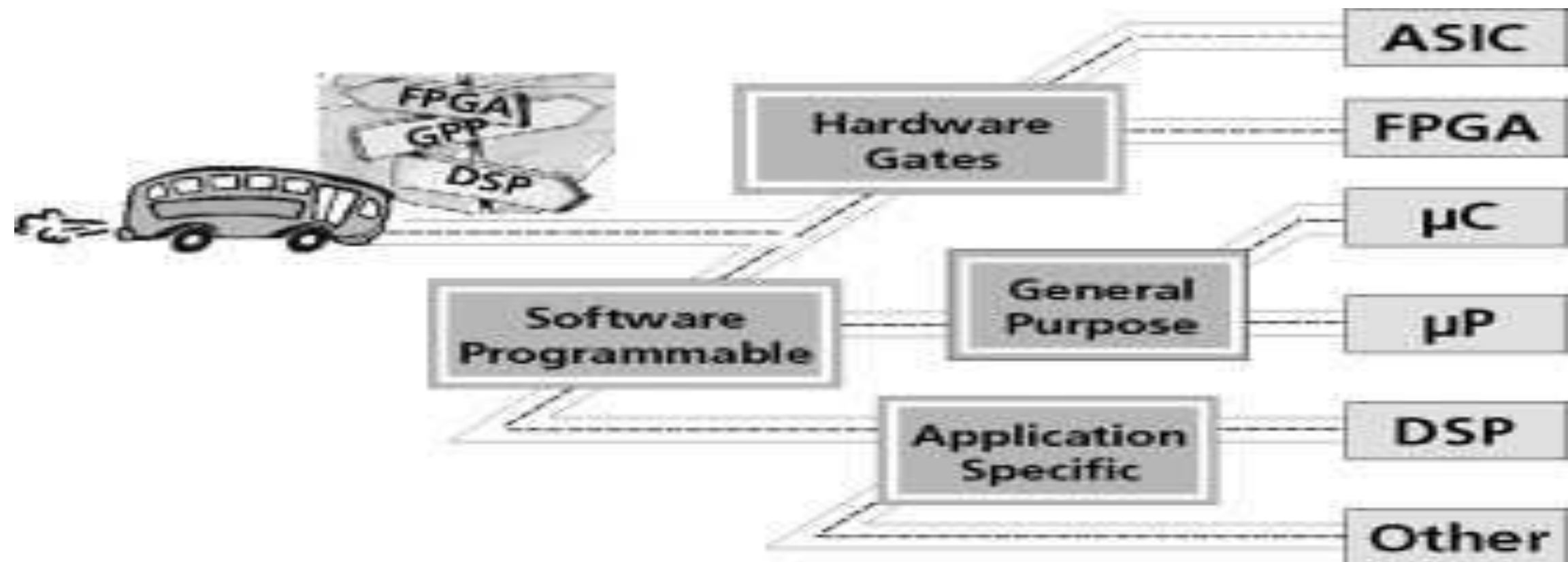



SYSTEM DESIGN USING GENERAL PURPOSE PROCESSOR



What is a general purpose processor in embedded system?

General Purpose Processor (GPP): GPP is **used for processing signal from input to output by controlling the operation of system bus, address bus and data bus inside** an embedded system.

General purpose microprocessors make use of **Von Neumann architecture** .



SYSTEM DESIGN USING GENERAL PURPOSE PROCESSOR



Figure : General-purpose processor basic architecture.

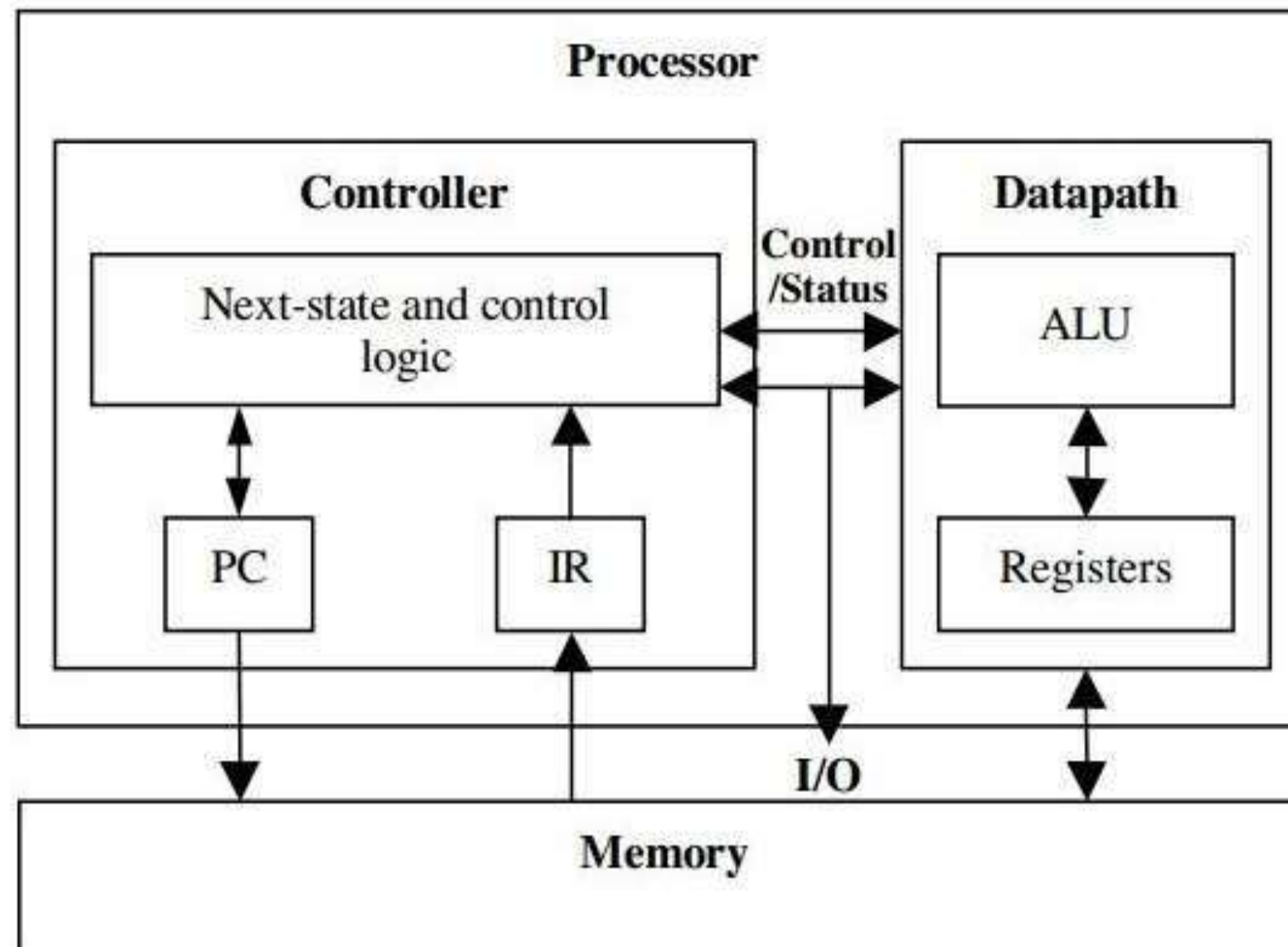



SYSTEM DESIGN USING GENERAL PURPOSE PROCESSOR



Four General Embedded System Types

◆ General Computing

- Applications similar to desktop computing, but in an embedded package
- Video games, set-top boxes, wearable computers, automatic tellers

◆ Control Systems

- Closed-loop feedback control of real-time system
- Vehicle engines, chemical processes, nuclear power, flight control

◆ Signal Processing

- Computations involving large data streams
- Radar, Sonar, video compression

◆ Communication & Networking

- Switching and information transmission
- Telephone system, Internet





SYSTEM DESIGN USING GENERAL PURPOSE PROCESSOR



- **Programmable device used in a variety of applications**
 - Also known as “microprocessor”
- **Features**
 - Program memory
 - General datapath with large register file and general ALU
- **User benefits**
 - Low time-to-market and NRE costs
 - High flexibility
- **“Pentium” the most well-known, but there are hundreds of others**

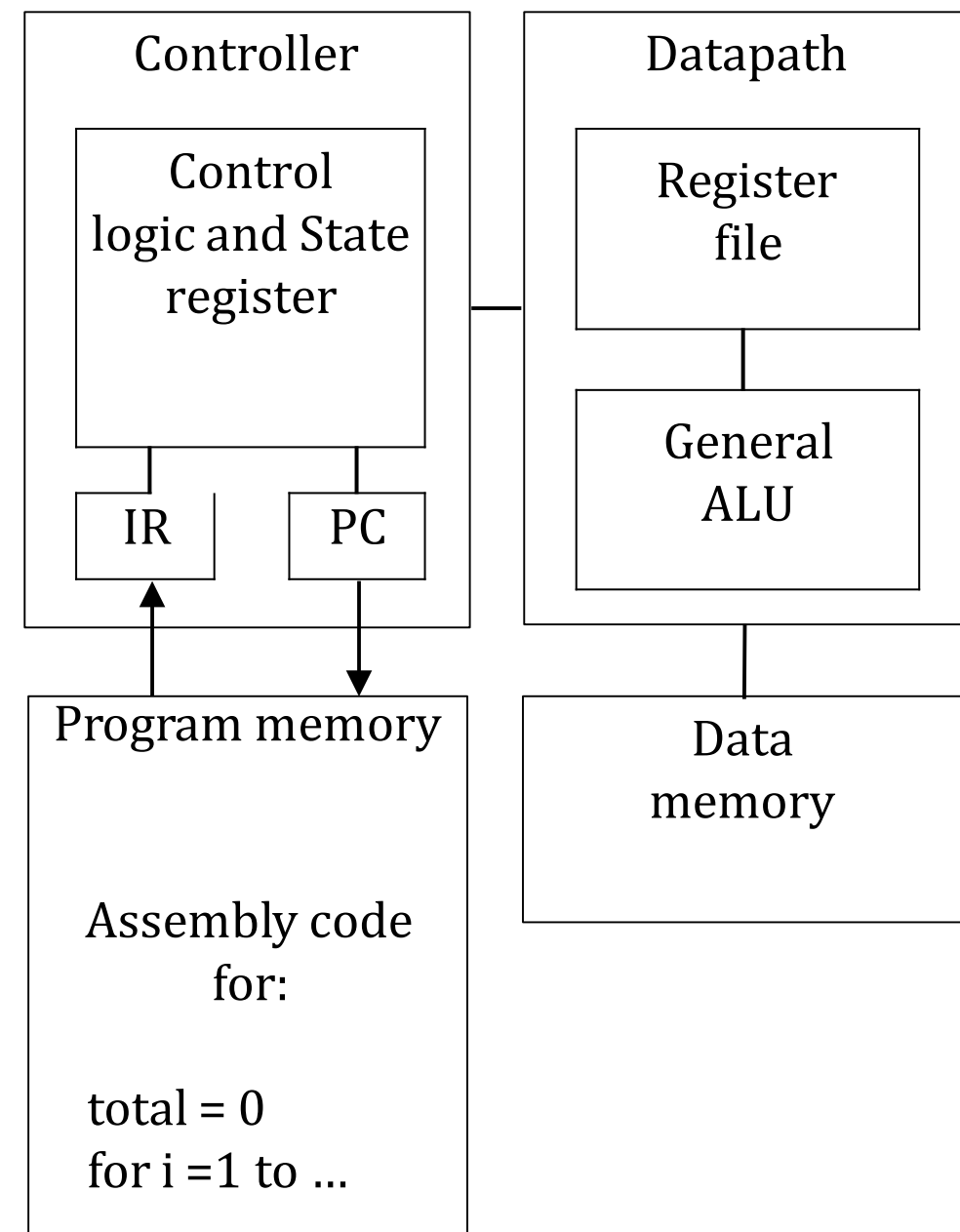



SYSTEM DESIGN USING GENERAL PURPOSE PROCESSOR



Single-purpose processors

- Digital circuit designed to execute exactly one program
 - a.k.a. coprocessor, accelerator or peripheral
- Features
 - Contains only the components needed to execute a single program
 - No program memory
- Benefits
 - Fast
 - Low power
 - Small size

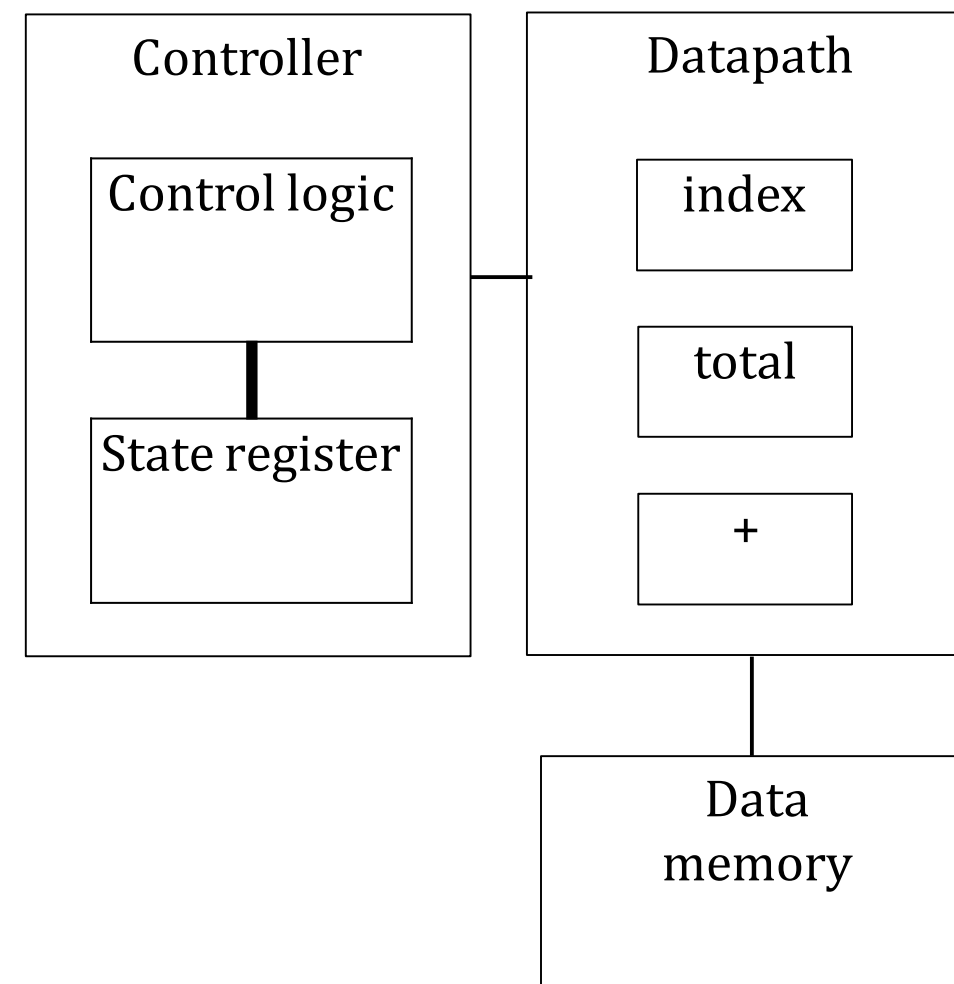



SYSTEM DESIGN USING GENERAL PURPOSE PROCESSOR



ACTIVITY



SYSTEM DESIGN USING GENERAL PURPOSE PROCESSOR



Application-specific processors

- Programmable processor optimized for a particular class of applications having common characteristics
 - Compromise between general-purpose and single-purpose processors
- Features
 - Program memory
 - Optimized datapath
 - Special functional units
- Benefits
 - Some flexibility, good performance, size and power
- DSP

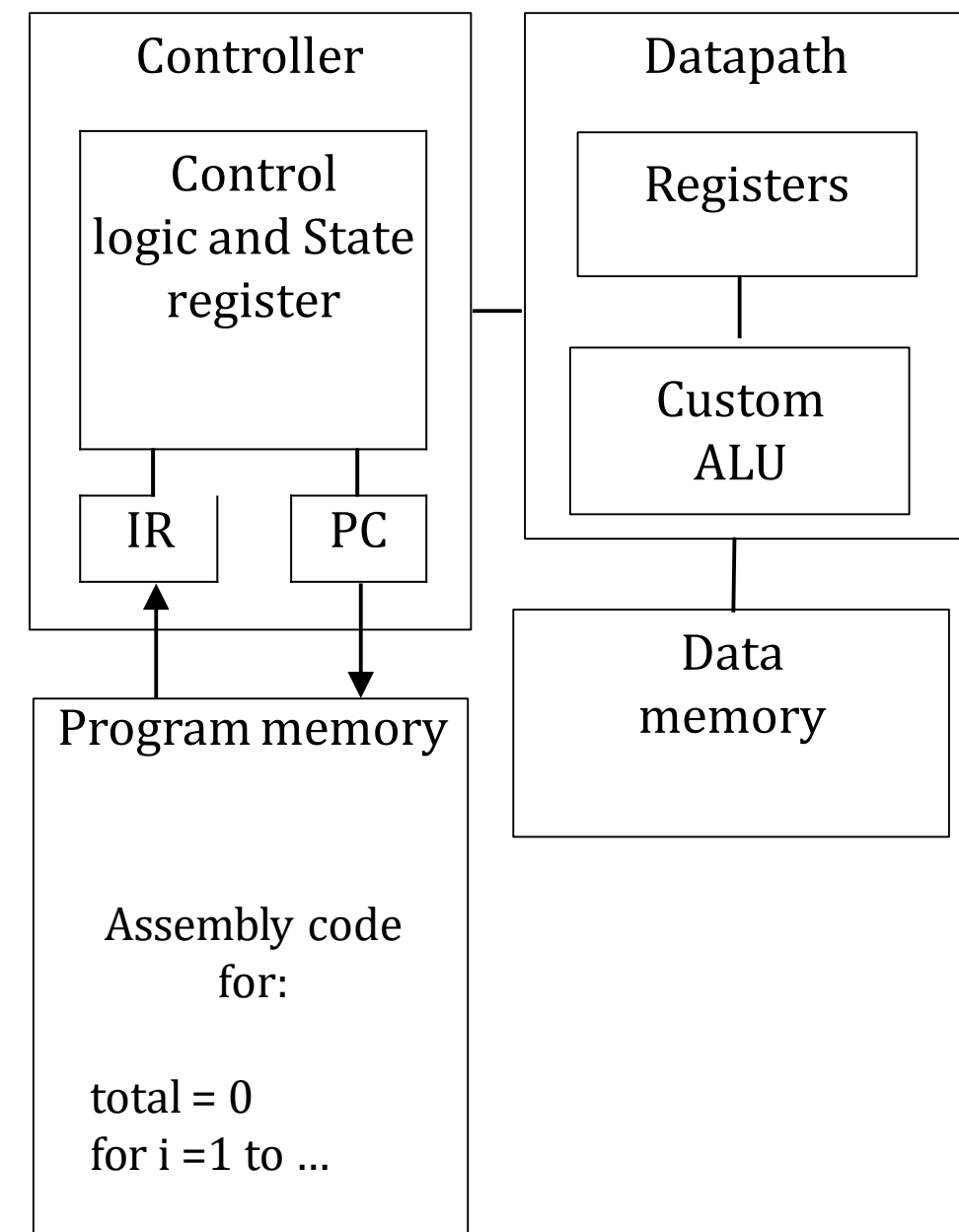



SYSTEM DESIGN USING GENERAL PURPOSE PROCESSOR



FPGA Architecture

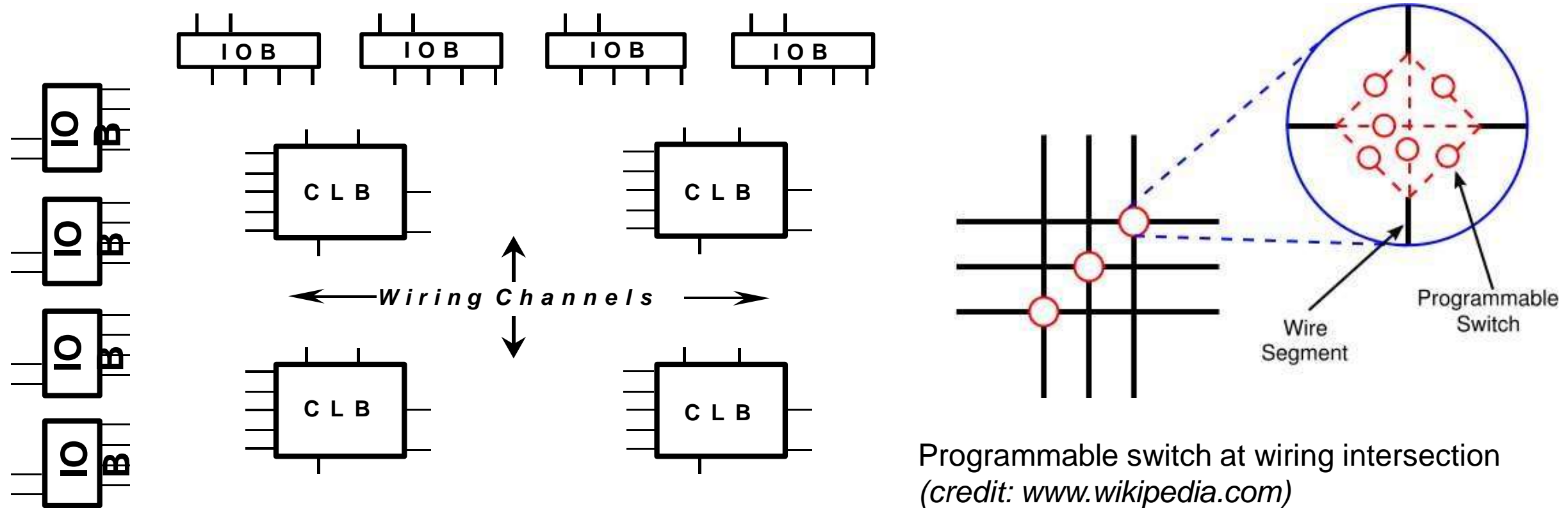

FPGA layout with Configurable Logic Blocks (CLB) and I/O Blocks (IOB) (credit: Katz's Contemporary Logic Design)

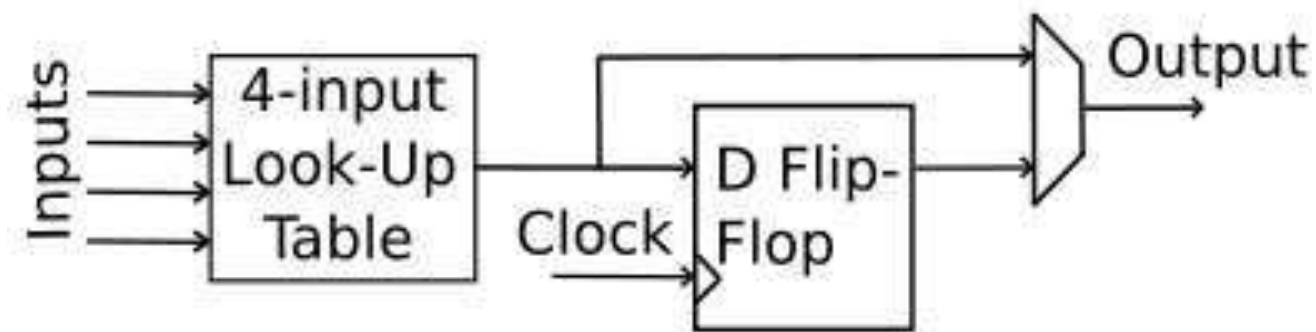



SYSTEM DESIGN USING GENERAL PURPOSE PROCESSOR



- Highly constrained products tend to use application specific processors
 - Many mobile phones (power & size constrained) contain ARM chips
 - Hi-Fi (high performance & time constrained) contain DSP chips

- ◆ **Hardware is mostly a recurring cost**

- Cost proportional to number of units manufactured

- ◆ **Software is a “one-time” non-recurring engineering design cost (NRE)**

- Paid for “only once”
 - But bug fixes may be expensive, or impossible
- Cost is related to complexity & number of functions
- Market pressures lead to feature creep
- **SOFTWARE Is Not FREE!!!!**

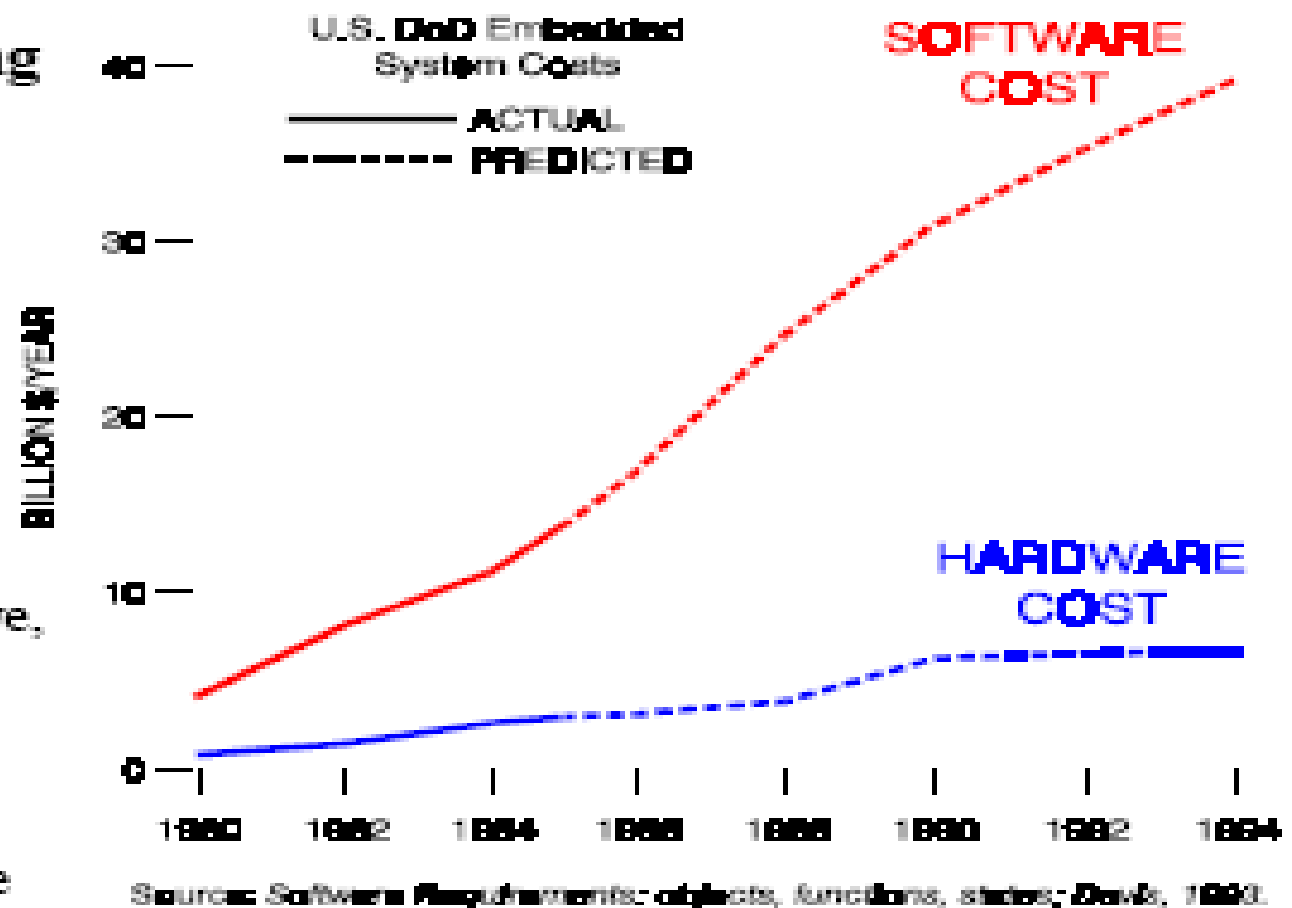



SYSTEM DESIGN USING GENERAL PURPOSE PROCESSOR



Hardware vs Software

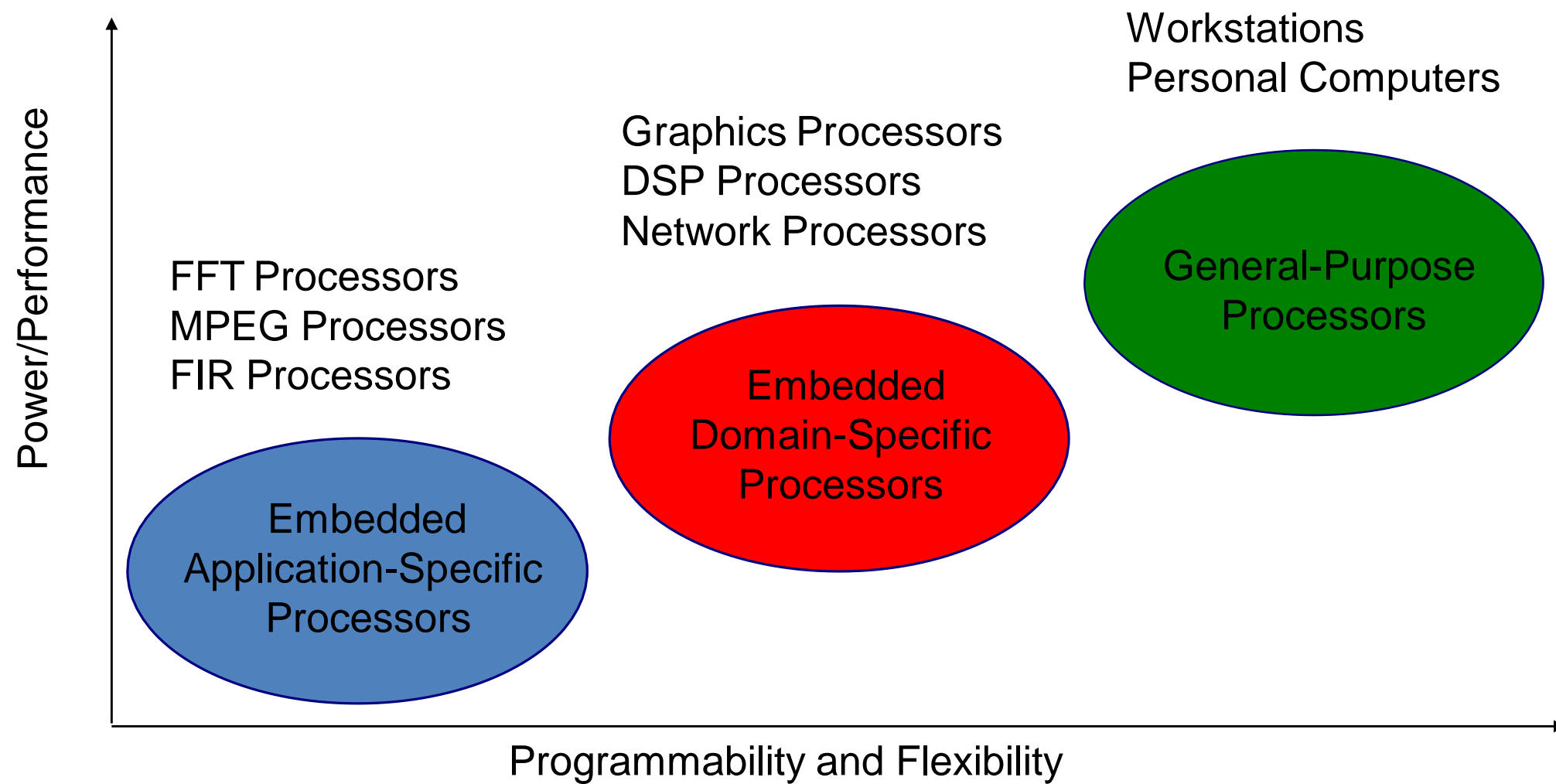



SYSTEM DESIGN USING GENERAL PURPOSE PROCESSOR



Levels of Embedded System Design

- Specification
 - Design productivity increases with the level of abstraction
 - The task of functional verification is very difficult at low abstraction levels
- Implementation
 - Efficient implementations require to exploit the low-level features of the target architecture





SYSTEM DESIGN USING GENERAL PURPOSE PROCESSOR



Future Embedded Systems

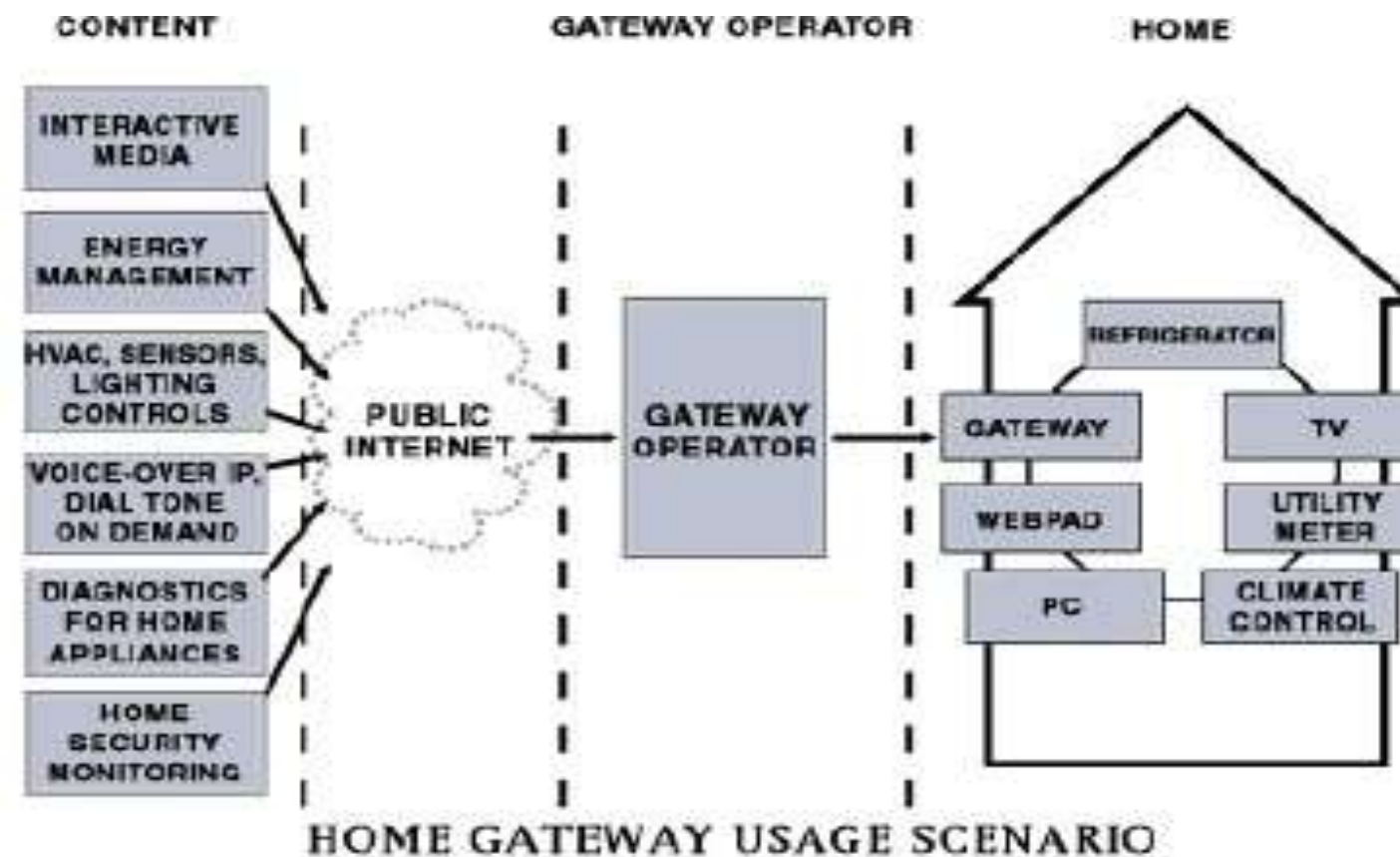

- ◆ **Will people adopt this other than as a toy?**
 - Will the same people who can't set time on a VCR be able to debug their house?
- ◆ **If we can make the system readily accessible, reliable, affordable, ...the possibilities are almost endless**



SUMMARY & THANK YOU