



# **SNS COLLEGE OF TECHNOLOGY**

**Coimbatore-35**

**An Autonomous Institution**

Accredited by NBA – AICTE and Accredited by NAAC – UGC with ‘A+’  
Grade

Approved by AICTE, New Delhi & Affiliated to Anna University,  
Chennai



## **DEPARTMENT OF ELECTRONICS & COMMUNICATION ENGINEERING**

### **19ECE308- WIRELESS TECHNOLOGIES FOR IOT**

III ECE / VI SEMESTER

UNIT 1 – OVERVIEW OF INTERNET OF THINGS

### **TOPIC 9 – Web communication protocols used by connected IoT/M2M devices,**



# Web communication protocols



- Data of connected devices routes over the web in two types of communication environments
  - Constrained RESTful Environment (CoRE)
  - Unconstrained Environment:



# Constrained Environment for Connected Devices



- Data is limited in size
- 10s of Bytes from a device
- Limited compared to data interchange of 1000s of bytes between web clients and web servers when using HTTP, TCP and IP



# Constrained Environment for Connected Devices



- Data routes over the low power and lossy (ROLL) network
- Devices may sleep most of the time in low power environment
- Awakes when required (when a client initiates)
- The connectivity breaks for long periods
- Have limited up intervals in lossy environment



# Constrained RESTful Environment (CoRE)



- The gathered data from number of devices consists of 100s of Bytes after enriching and consolidating at Gateway
- Communication framework enables that data of networked devices communicate over the Internet using the REST software architecture

# [10s and 100s of Bytes Communication Framework Constrained RESTful Environment (CoRE)]

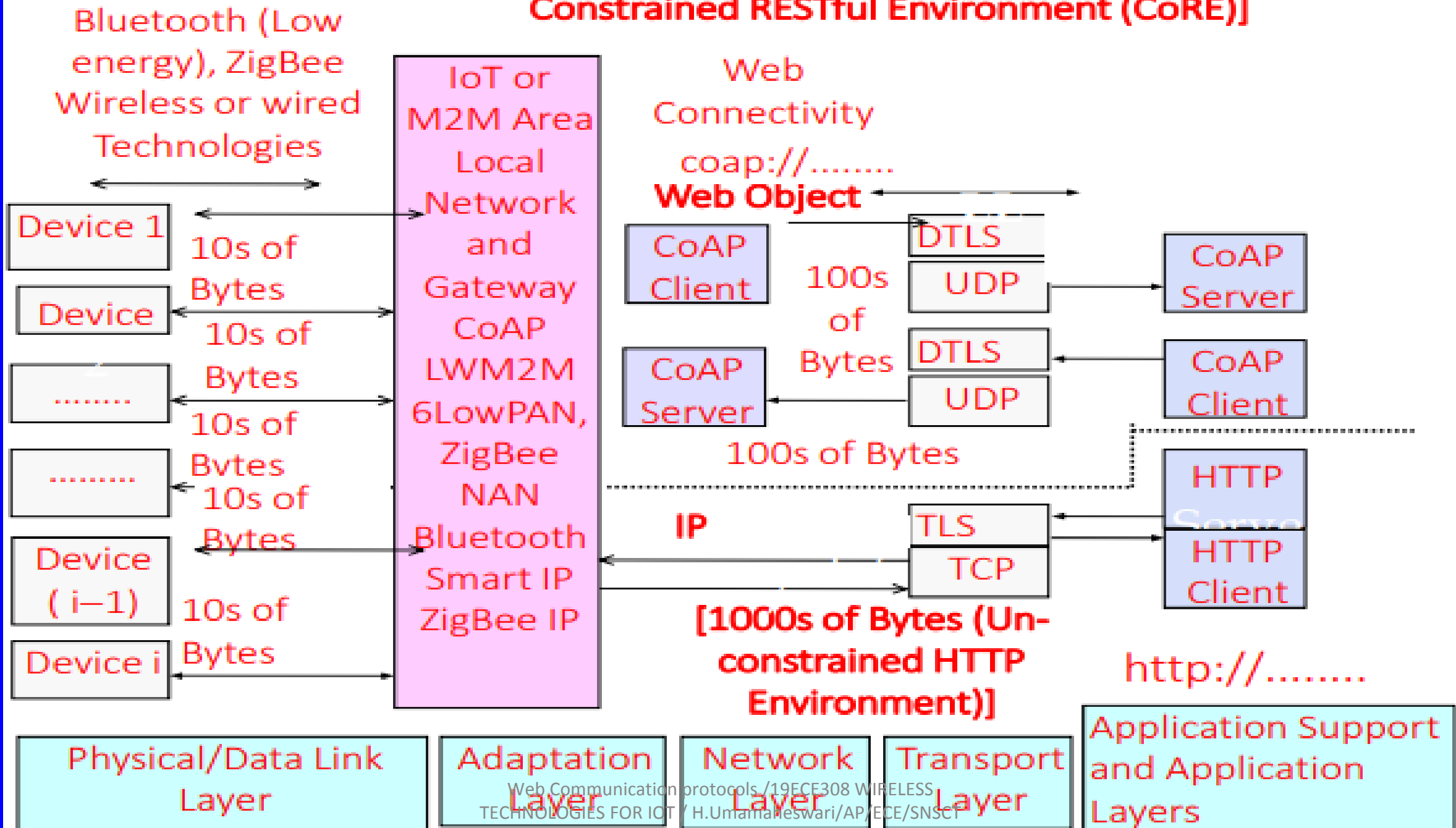



# CoAP (Constrained Application Protocol)



- An IETF recommended protocol for constrained environment devices
- A web-object's data transfer standard protocol for sending a request or response
- For example, RESTful CoAP



# CoAP Client and Server



- Object or resource uses CoAP
- CoAP client at a device, IoT/M2M Area Local Network or Gateway sends requests to a server
- CoAP server sends the responses, messages, resources and notifications



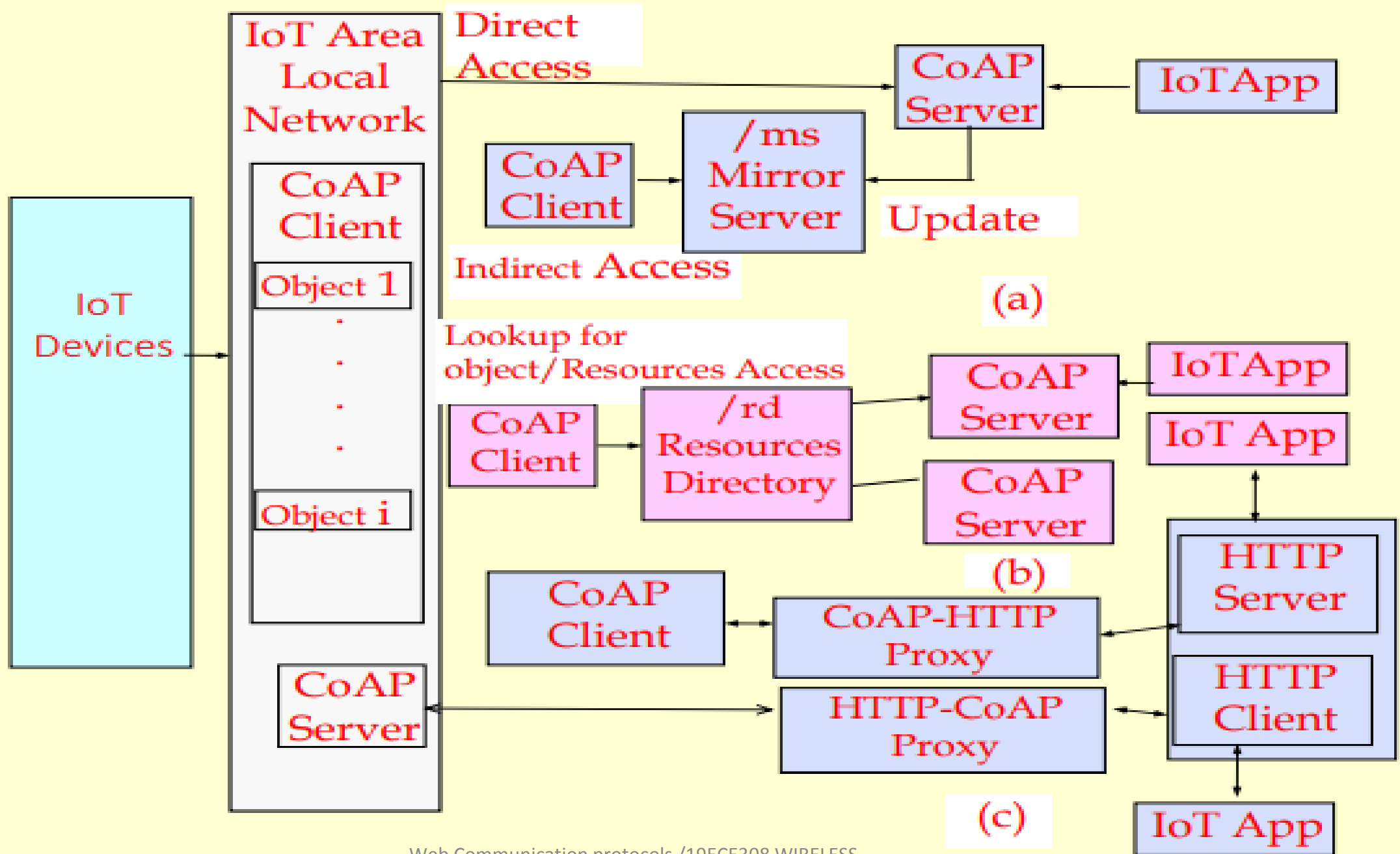



# CoAP Features



- Standard organisation IETF defined Application support layer protocol
- CoAP web-objects communication using request/response interactions model



# CoAP Client and Server



- A specialized web transfer protocol used for CoRE using ROLL network.
- Use of object model for resources, and each object can have single or multiple instances.
- Each resource can have single or multiple instances



# CoAP Features



- Supports resource directory and resource discovery functions.
- The resource identifiers use the URIs coap://...
- Small message-header of 4 bytes.
- CoRE communication is asynchronous communication over the  
ROLL
- Integrates easily with the web using the CoAP application cross-  
protocol proxies. Because HTTP and CoAP both share the REST  
model



# UDP (Universal Datagram Protocol)



- A transport layer standard protocol sending a request or response datagrams



# DTLS (Datagram Transport Layer Security protocol)



- Provisions for three types of security services (integrity, authentication and confidentiality)
- Security binding with PSK or RPK or Certificate



**THANK YOU**