



SNS COLLEGE OF TECHNOLOGY

Coimbatore-35

An Autonomous Institution

Accredited by NBA – AICTE and Accredited by NAAC – UGC with 'A+' Grade
Approved by AICTE, New Delhi & Affiliated to Anna University, Chennai



DEPARTMENT OF ELECTRONICS & COMMUNICATION ENGINEERING

19ECE308- WIRELESS TECHNOLOGIES FOR IOT

III ECE / VI SEMESTER

UNIT 1 – OVERVIEW OF INTERNET OF THINGS

TOPIC 4 –Sources of IoT



Sources of IoT



1. Sensors and Control Units
2. RFID
3. WSNs
- 4: Communication Modules and Software Development Tools



Sensors



- **Analog Sensors:** thermistor, photoconductor, pressure gauge and Hall sensor
- **Digital Sensors:** touch sensor, proximity sensor, metal sensor, traffic
- **Presence sensor,** rotator encoder for measuring angles, linear encoders for measuring position



Control Unit



- Most commonly used control unit in IoT consists of a microcontroller unit (MCU) or
- A custom chip or core in a VLSI or an SoC
- Popular microcontrollers: ATmega 328, ATmega 32u4, ARM Cortex and ARM LPC.



Control Unit

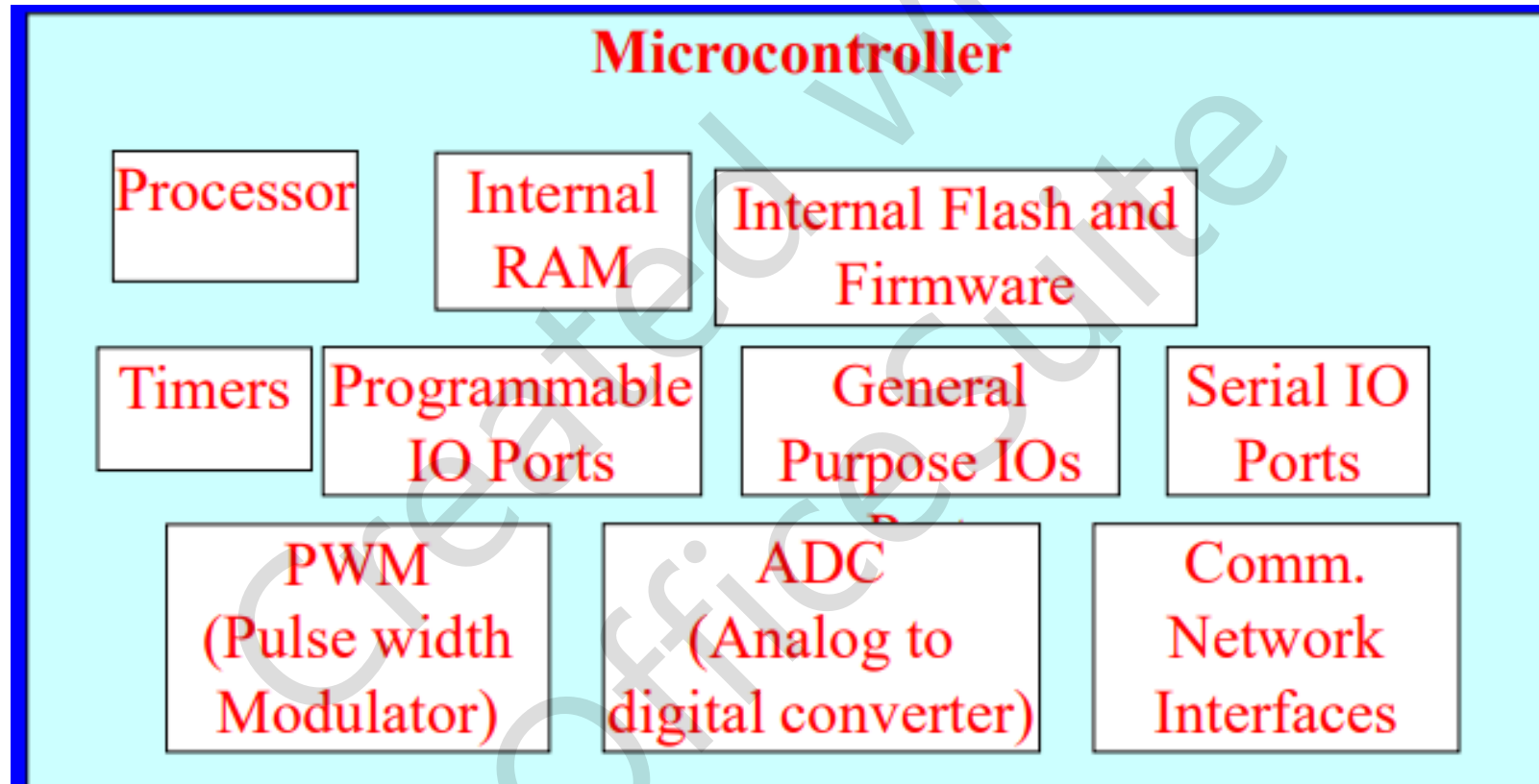



Arduino Boards



- E.g. Arduino Yún
- Using Microcontroller ATmega32u4
- Includes Wi-Fi, Ethernet, USB port, micro-SD card slot and three reset buttons
- Runs Linux



Intel Galileo



- Intel Galileo board
- A line of Arduino-certified development boards.
- Intel x86, Intel SOC X1000 Quark based System-On-Chip
- Power over Ethernet (PoE) and 6 Analog Inputs



BeagleBoard



- Very low power requirement
- Card like computer
- Can run Android and Linux
- Open source Hardware designs and the software for the IoT devices are



Raspberry Pi



- Wi-Fi-connected device
- Included code open source RasWIK



2. RFID-Radio Frequency ID



- An identification system
- Tagging and labelling
- Tiny chips: passive, active and battery powered when reader nearby Wireless Communication range 10 cm to 200 m
- Standard frequency ranges: 120-150 kHz, 13.56 MHz, 433 MHz and higher in UHF and Microwave regions



RFID Applications



- Tracking and inventory control
- Identification in supply chain systems
- Access to buildings and road tolls
- Secured store center entries
- Devices such as RFID based temperature sensors
- Applications in factory design, 3PL-management, brand protection, and anti-counterfeiting
- Business processes for payment, leasing, insurance, and quality management



3. WSNs



- Defined as a network in which each sensor node connect wirelessly
- Capabilities of computations
- Data compaction, aggregation and analysis
- Each with communication as well as networking capabilities.
- Autonomous: Independent computing power and capability to send requests and receive responses, and data forward and routing capabilities.



4: Communication Modules and Software Development Tools



- Device message-queue
- A device message-cache stores the received messages
- Protocol handlers:
CoAP, HTTP, MQTT, TLS, DTLS
LWM2M, CoAP-SMS, CoAP-MQ



Communication Module

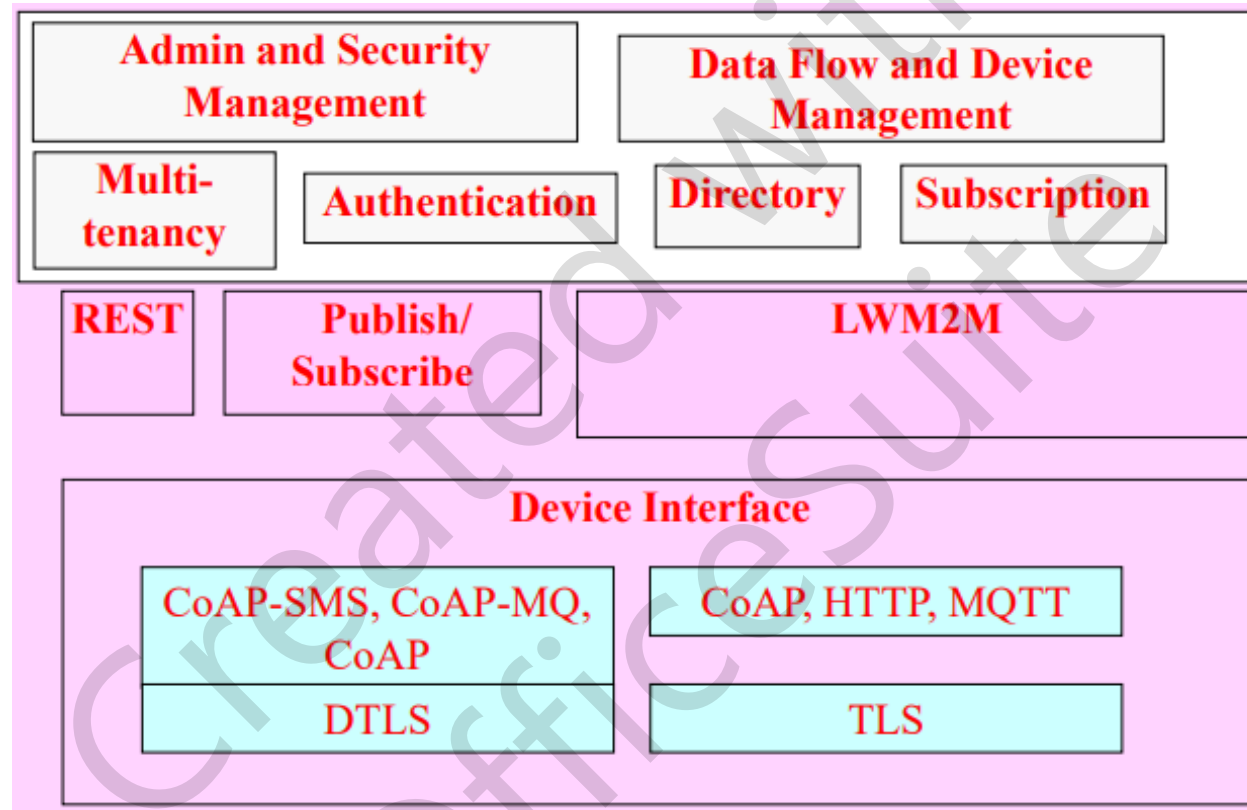

Fig-mbed API and device interfacing component



Representational state transfer (REST) architectural style



- Used for HTTP access
- GET, POST, PUT and DELETE methods for the resources
- Building web services



Middleware



- OpenIoT (open source middleware)
- Communication with sensor clouds and Cloud-based 'sensing as a service'
- IoTSyS middleware provisioning of communication stack for smart devices using IPv6, oBIX, 6LoWPAN
- CoAP and multiple standards and protocols. The oBIX is standard XML and web services
- Protocol oBIX (Open Building Information Xchange).



OS



- Raspbian: a popular Raspberry Pi operating system Based on the Debian distribution of Linux.
- AllJoyn, open source OS created by Qualcomm Cross-platform OS with APIs available for Android, iOS, OS X, Linux

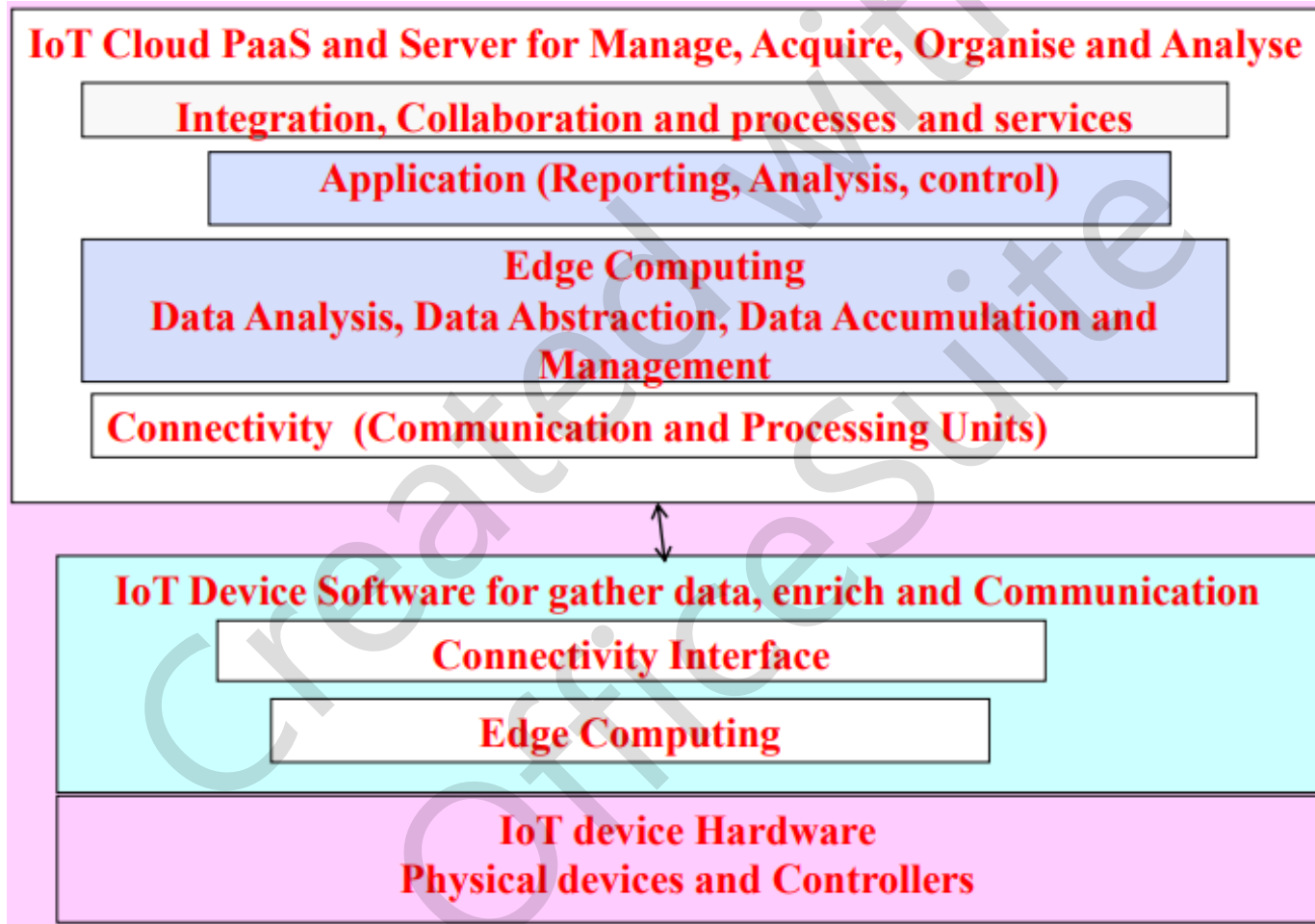

The IOT software architecture



cloud Platforms as a Service



- Sense, ThingWorx, Nimbits, Xively,
- openHAB, AWS IoT, IBM BlueMix, CISCO IoT, IOx and Fog, EvryThng, Azure, TCS CUP



Summary



We learnt

- (i) Sensors, Control units, Microcontrollers
- (ii) Sources for the IoTs: Arduino, Intel Galileo, Raspberry Pi, BeagleBone,
- (iii) RFIDs,
- (iv) WSNs
- (v) Communication module and software development tools