



SNS COLLEGE OF TECHNOLOGY

Coimbatore-35

An Autonomous Institution

Accredited by NBA – AICTE and Accredited by NAAC – UGC with ‘A+’ Grade

Approved by AICTE, New Delhi & Affiliated to Anna University, Chennai



DEPARTMENT OF COMPUTER SCIENCE AND ENGINEERING

SOFTWARE ENGINEERING

(Agile UX/UI)

UNIT 5-Software Testing



STRATEGIC APPROACH OF Software Testing

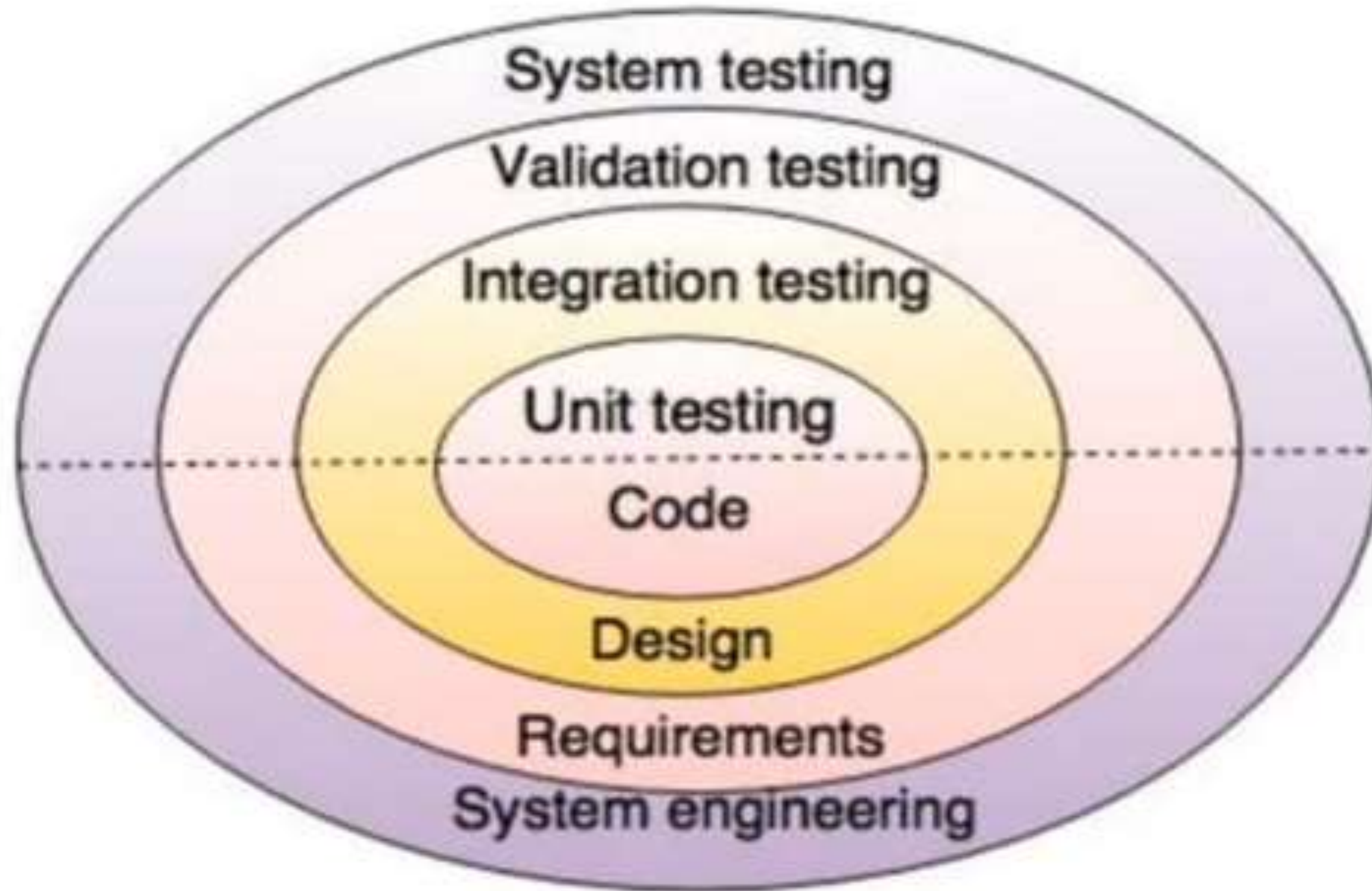

Fig. - Testing Strategy



Software Testing Fundamentals



- Testing is the process of valuating a system with the specific intent of finding errors prior to deliver to end user
- Therefore, you should design and implement a computer based system or a product with “testability” in mind
- Testability :

“ Software Testability is simply how easily can be tested “

The following characteristics leads to testable software: (7 characteristics)

- **Operability** : The better it work the more efficiently it can be tested
- **Observability**: What you see is what you test
- **Controllability** :The better we can control the software , the more the testing can be automated and optimized



Software Testing Fundamentals



- **Decomposability** : By controlling the scope of testing , we can more quickly isolate the problems and perform smarter testing
- **Simplicity** : The less there is to test , the more quickly we can test it
- **Stability** : The fewer the change, the fewer the disruptions to testing
- **Understandability** : The more information we have the smarter we will test



Software Testing Fundamentals



Test Characteristics: Kaner, Falk, and Nguyen suggest the following attributes of a “good” test:

- *A good test has a high probability of finding an error.*
- *A good test is not redundant.*
- *A good test should be “best of breed”*
- *A good test should be neither too simple nor too complex*



Software Testing Fundamentals



INTERNAL AND EXTERNAL VIEWS OF TESTING

Any engineered product can be tested in one of **two** ways:

- (1) Knowing the specified function that a product has been designed to perform, tests can be conducted that demonstrate each function is fully operational while at the same time searching for errors in each function.
- (2) Knowing the internal workings of a product.

The **first** test approach takes an **external view** and is called **black-box testing**.

The **second** requires an **internal view** and is termed **white-box**



Software Testing Fundamentals



INTERNAL AND EXTERNAL VIEWS OF TESTING

Any engineered product can be tested in one of **two** ways:

- (1) Knowing the specified function that a product has been designed to perform, tests can be conducted that demonstrate each function is fully operational while at the same time searching for errors in each function.
- (2) Knowing the internal workings of a product.

The **first** test approach takes an **external view** and is called **black-box testing**.

The **second** requires an **internal view** and is termed **white-box**



Software Testing Fundamentals



What is White Box Testing ?

WHITE BOX TESTING APPROACH

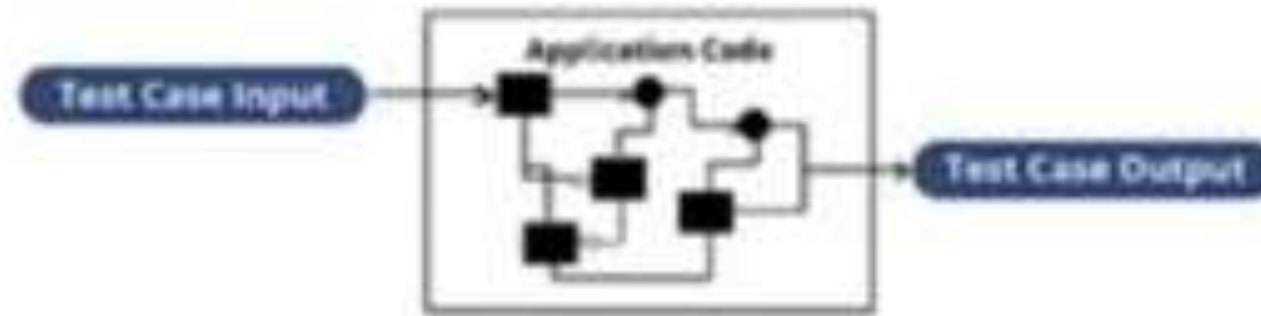

BLACK BOX TESTING APPROACH

