

CANTILEVER:

A Cantilever is a beam fixed horizontally at one end and loaded at other end.

Depression of a cantilever loaded at its ends:

Theory:

The cantilever OA is fixed at O, its length is l and 'W' be the weight loaded at other end. Due to load it moves to OA'.

Let us consider an element PQ of the beam of length dx, at a distance x from fixed end. 'C' be the centre of curvature and R be the radius of curvature.

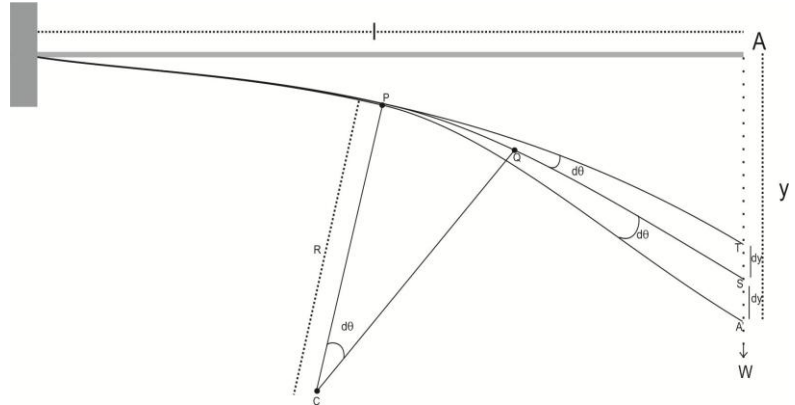

Due to the load (W) applied at free end, an external couple is created between A and Q, arm of couple is (l - x).

External bending movement = $W \times (l - x)$ -----(1)

Internal bending movement = $\frac{YI}{R}$ -----(2)

Under equilibrium condition,

External bending movement = Internal bending movement

$$\therefore R = \frac{YI}{W(l - x)} \text{ ----- (3)}$$

From the figure arc length

$$PQ = Rd\theta = dx$$

$$d\theta = \frac{dx}{R} \text{ -----(4)}$$

On substituting R Value

$$d\theta = \frac{dx}{YI} W(l - x) \text{ -----(5)}$$

From ΔQAS

$$\sin\theta = \frac{dy}{l-x}$$

$$dy = d\theta(1 - x) \text{ ----- (6)}$$

On sub (5) in (6) we get,

$$dy = \frac{W(1 - x)^2}{YI} dx$$

∴ Total depression is by integrating the above within the limit 0 to 1.

$$\therefore y = \frac{W}{YI} \int_0^1 (1 - x)^2 dx$$

On solving we get,

$$y = \frac{W}{YI} \cdot \frac{l^3}{3}$$

This equation gives the depression of the cantilever.

Special Cases:

- (i) Rectangular cross section. For,

$$I = \frac{bd^3}{12}$$

$$\text{Depression produced } y = \frac{4Wl^3}{Ybd^3}$$

- (ii) Circular cross section, For $I = \frac{\pi r^4}{4}$

$$\text{Depression Produced } y = \frac{4Wl^3}{3\pi r^4 Y}$$

'r' is the radius of the circular cross section.