

## Hydraulic Pump

A hydraulic pump is a mechanical source of power that converts mechanical power into hydraulic energy. It generates flow with enough power to overcome pressure induced by the load at the pump outlet. When a hydraulic pump operates, it creates a vacuum at the pump inlet, which forces liquid from the reservoir into the inlet line to the pump and by mechanical action delivers this liquid to the pump outlet and forces it into the hydraulic system.

### Classifications of Pump

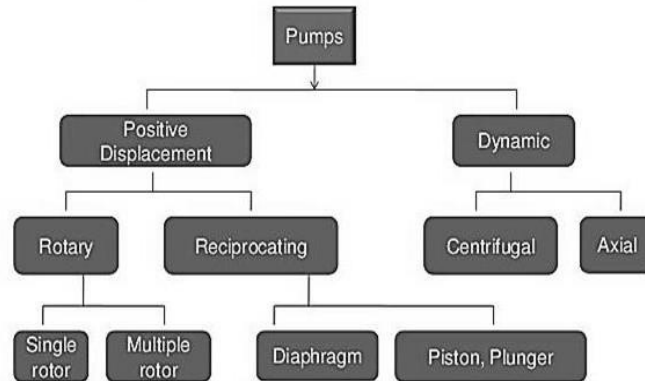

### Centrifugal Pump

The main components of a centrifugal pump are:

- i) Impeller
- ii) Casing
- iii) Suction pipe
- iv) Foot valve with strainer,
- v) Delivery pipe
- vi) Delivery valve.

**Impeller** is the rotating component of the pump. It is made up of a series of curved vanes. The impeller is mounted on the shaft connecting an electric motor.

**Casing** is an air tight chamber surrounding the impeller. The shape of the casing is designed in such a way that the kinetic energy of the impeller is gradually changed to potential energy. This is achieved by gradually increasing the area of cross section in the direction of flow.

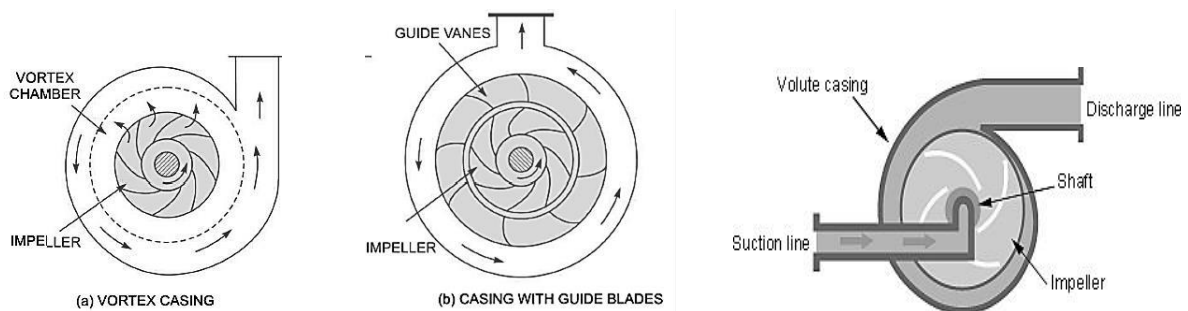
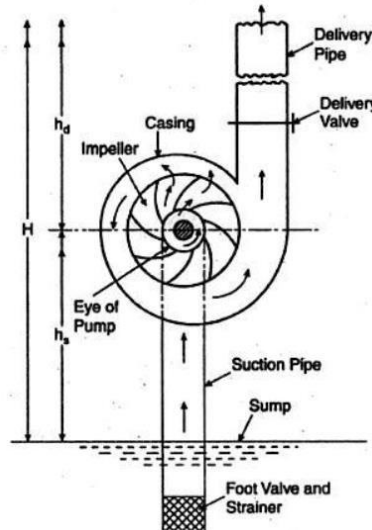

**Fig. 1** Types of Casing

**Suction pipe:** It is the pipe connecting the pump to the sump, from where the liquid has to be lifted up.

**Foot valve with strainer:** The foot valve is a non-return valve which permits the flow of the liquid from the other words the foot valve opens only in the upward direction. The strainer is a mesh surrounding the valve, it p debris and silt into the pump.

**Delivery pipe** is a pipe connected to the pump to the overhead tank. Delivery valve is a valve which can regulate the pump.



**Fig. 2** Main parts of a centrifugal pump

### Working

A centrifugal pump works on the principle that when a certain mass of fluid is rotated by an external source, it is thrown away from the central axis of rotation and a centrifugal head is impressed which enables it to rise to a higher level.

Working operation of a centrifugal pump is explained in the following steps:

1. Close the delivery valve and prime the pump.
2. Start the motor connected to the pump shaft, this causes an increase in the impeller pressure.
3. Open the delivery valve gradually, so that the liquid starts flowing into the deliver pipe.
4. A partial vacuum is created at the eye of the centrifugal action, the liquid rushed from the sump to the pump due to pressure difference at the two ends of the suction pipe.
5. As the impeller continues to run, move & more liquid are made available to the pump at its eye. Therefore impeller increases the energy of the liquid and delivers it to the reservoir.
6. While stopping the pump, the delivery valve should be closed first; otherwise there may be back flow from the reservoir.

It may be noted that a uniform velocity of flow is maintained in the delivery pipe. This is due to the special design of the casing. As the flow proceeds from the tongue of the casing to the delivery pipe, the area of the casing increases. There is a corresponding change in the quantity of the liquid from the impeller. Thus a uniform flow occurs in the delivery pipe.

Centrifugal pump converts rotational energy, often from a motor, to energy in a moving fluid. A portion of the energy goes into kinetic energy of the fluid. Fluid enters axially through eye of the casing, is caught up in the impeller blades, and is whirled tangentially and radially outward until it leaves through all circumferential parts of the impeller into the diffuser part of the casing. The fluid gains both velocity and pressure while passing through the impeller. The doughnut-shaped diffuser, or scroll, section of the casing

decelerates the flow and further increases the pressure. The negative pressure at the eye of the impeller helps to maintain the flow in the system. If no water is present initially, the negative pressure developed by the rotating air, at the eye will be negligibly small to suck fresh stream of water. As a result the impeller will rotate without sucking and discharging any water content. So the pump should be initially filled with water before starting it. This process is known as priming.

### Use of the Casing

From the illustrations of the pump so far, one speciality of the casing is clear. It has an increasing area along the flow direction. Such increasing area will help to accommodate newly added water stream, and will also help to reduce the exit flow velocity. Reduction in the flow velocity will result in increase in the static pressure, which is required to overcome the resistance of pumping system.

### NPSH - Overcoming the problem of Cavitation

If pressure at the suction side of impeller goes below vapour pressure of the water, a dangerous phenomenon could happen. Water will start to boil forming vapour bubbles. These bubbles will move along with the flow and will break in a high pressure region. Upon breaking the bubbles will send high impulsive shock waves and spoil impeller material overtime. This phenomenon is known as cavitation. More the suction head, lesser should be the pressure at suction side to lift the water. This fact puts a limit to the maximum suction head a pump can have. However Cavitation can be completely avoided by careful pump selection. The term NPSH (Net Positive Suction Head) helps the designer to choose the right pump which will completely avoid Cavitation. NPSH is defined as follows:

$$NPSH = \left( \frac{P}{\rho g} + \frac{V^2}{2g} \right)_{suction} - \frac{P_v}{\rho g}$$

Where  $P_v$  is vapour pressure of water

$V$  is speed of water at suction side

### Work done by the centrifugal pump (or by impeller) on water

#### Velocity triangles at inlet and outlet

Let,

$D_1$  : Diameter of impeller at inlet =  $2 \times R_1$

$D_2$  : Diameter of impeller at outlet =  $2 \times R_2$

$N$  : Speed of impeller in rpm

$u_1$  : Tangential blade velocity at inlet =  $wR_1 = \left( \frac{2\pi N}{60} \right) R_1$

$u_2$  : Tangential blade velocity at outlet =  $wR_2 = \left( \frac{2\pi N}{60} \right) R_2$

$V$  : Absolute velocity

$V_r$  : Relative velocity

$V_f$  : Velocity of flow

$V_w$  : Velocity of whirl

$\alpha_1$  : Angle made by absolute velocity  $V_1$  at inlet

$\theta$  : Inlet angle of vane

$\phi$  : Outlet angle of vane

$\beta$  : Discharge angle of absolute velocity at outlet

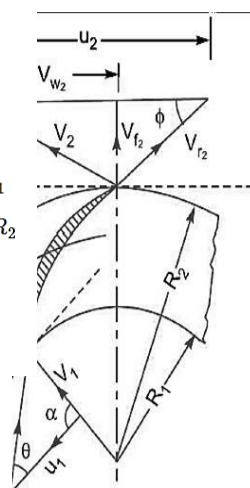

*Angular momentum = mass × tangential velocity × Radius*

*Angular momentum entering the impeller per sec =  $m \cdot V_{w1} \cdot R_1$*

*Angular momentum leaving the impeller per sec =  $m \cdot V_{w2} \cdot R_2$*

*Torque transmitted = rate of change of angular momentum*

$$\begin{aligned} &= m \cdot V_{w2} \cdot R_2 - m \cdot V_{w1} \cdot R_1 \\ &= \frac{w}{g} (V_{w2} \cdot R_2 - V_{w1} \cdot R_1) \end{aligned}$$

Since the work done in unit time is given by the product of torque and angular velocity

W.D per sec = Torque x W

$$= \frac{w}{g} (V_{w2} \cdot R_2 w - V_{w1} \cdot R_1 w)$$

But  $R_2 w = u_2$  and  $R_1 w = u_1$

$$\text{W.D per sec} = \frac{w}{g} (V_{w2} u_2 - V_{w1} u_1)$$

Work done by impeller per N weight of liquid per sec,

$$\text{W.D} = \frac{1}{g} (V_{w2} u_2 - V_{w1} u_1)$$

But  $V_{w1} = 0$  since entry is radial

$$\text{W.D per N weight per sec} = \frac{V_{w2} \cdot u_2}{g}$$

## Definitions of Heads and Efficiencies of a centrifugal pump

**1. Suction Head ( $h_s$ ).** It is the vertical height of the centre line of the centrifugal pump above the water surface in the tank or pump from which water is to be lifted as shown in Fig. This height is also called suction lift and is denoted by ' $h_s$ '.

**2. Delivery Head ( $h_d$ ).** The vertical distance between the centre line of the pump and the water surface in the tank to which water is delivered is known as delivery head. This is denoted by ' $h_d$ '.

**3. Static Head ( $H_s$ ).** The sum of suction head and delivery head is known as static head. This is represented by ' $H_s$ ' and is written as

$$H_s = h_s + h_d.$$

**4. Manometric Head ( $H_m$ ).** The manometric head is defined as the head against which a centrifugal pump has to work. It is denoted by ' $H_m$ '. It is given by the following expressions :

(a)  $H_m = \text{Head imparted by the impeller to the water} - \text{Loss of head in the pump}$

$$= \frac{V_{w2} u_2}{g} - \text{Loss of head in impeller and casing}$$

$$= \frac{V_{w2} u_2}{g} \quad \dots \text{if loss of pump is zero}$$

(b)  $H_m = \text{Total head at outlet of the pump} - \text{Total head at the inlet of the pump}$

$$= \left( \frac{P_o}{\rho g} + \frac{V_o^2}{2g} + Z_o \right) - \left( \frac{P_i}{\rho g} + \frac{V_i^2}{2g} + Z_i \right) \quad \dots (1)$$

$$(c) \quad H_m = h_s + h_d + h_{f_s} + h_{f_d} + \frac{V_d^2}{2g}$$

where  $h_s$  = Suction head,  $h_d$  = Delivery head,  
 $h_{f_s}$  = Frictional head loss in suction pipe,  $h_{f_d}$  = Frictional head loss in delivery pipe,  
 $V_d$  = Velocity of water in delivery pipe.

**(a) Manometric Efficiency ( $\eta_{man}$ ).**

$$\eta_{man} = \frac{\text{Manometric head}}{\text{Head imparted by impeller to water}}$$

$$= \frac{H_m}{\left(\frac{V_{w_2} u_2}{g}\right)} = \frac{gH_m}{V_{w_2} u_2}$$

The power at the impeller of the pump is more than the power given to the water at outlet of the pump. The ratio of the power given to water at outlet of the pump to the power available at the impeller, is known as manometric efficiency.

**(b) Mechanical Efficiency ( $\eta_m$ ).**

$$\eta_m = \frac{\text{Power at the impeller}}{\text{Power at the shaft}}$$

$$\text{The power at the impeller in kW} = \frac{\text{Work done by impeller per second}}{1000}$$

$$= \frac{W}{g} \times \frac{V_{w_2} u_2}{1000}$$

ie pump to the power input to

$$\eta_m = \frac{\frac{W}{g} \left(\frac{V_{w_2} u_2}{1000}\right)}{\text{S.P.}}$$

$$\frac{H_m}{1000}$$

or

where S.P. = Shaft power.

= S.P. of the pump.

$$\therefore \eta_o = \frac{\left(\frac{WH_m}{1000}\right)}{\text{S.P.}}$$

Also  $\eta_o = \eta_{man} \times \eta_m$ .

## **PRIMING OF A CENTRIFUGAL PUMP**

Priming of a centrifugal pump is defined as the operation in which the suction pipe, casing of the pump and a portion of the delivery pipe upto the delivery valve is completely filled up from outside source with the liquid to be raised by the pump before starting the pump. Thus the air from these parts of the pump is removed and these parts are filled with the liquid to be pumped.

## **CAVITATION**

Cavitation includes formation of vapour bubbles of the flowing liquid and collapsing of the vapour bubbles. Formation of vapour bubbles of the flowing liquid take place only whenever the pressure in any region falls below vapour pressure. When the pressure of the flowing liquid is less than its vapour pressure, the liquid starts boiling and vapour bubbles are formed. These vapour bubbles are carried along with the flowing liquid to higher pressure zones where these vapours condense and bubbles collapse. Due to sudden collapsing of the bubbles on the metallic surface, high pressure is produced and metallic surfaces are subjected to high local stresses. Thus the surfaces are damaged.

**Cavitation in Centrifugal Pumps.** In centrifugal pumps the cavitation may occur at the inlet of the impeller of the pump, or at the suction side of the pumps, where the pressure is considerably reduced. Hence if the pressure at the suction side of the pump drops below the vapour pressure of the liquid then the cavitation may occur. The cavitation in a pump can be noted by a sudden drop in efficiency and head. In order to determine whether cavitation will occur in any portion of the suction side of the pump, the critical value of Thoma's cavitation factor ( $\sigma$ ) is calculated.

### **Precaution Against Cavitation.**

(i) The pressure of the flowing liquid in any part of the hydraulic system should not be allowed to fall below its vapour pressure. If the flowing liquid is water, then the absolute pressure head should not be below 2.5 m of water.

(ii) The special materials or coatings such as aluminium-bronze and stainless steel, which are cavitation resistant materials, should be used.

### **Effects of Cavitation.**

(i) The metallic surfaces are damaged and cavities are formed on the surfaces.

(ii) Due to sudden collapse of vapour bubble, considerable noise and vibrations are produced.

(iii) The efficiency of a turbine decreases due to cavitation. Due to pitting action, the surface of the turbine blades becomes rough and the force exerted by water on the turbine blades decreases. Hence, the work done by water or output horse power becomes less and thus efficiency decreases.

$$H_m = \left( 30 + \frac{5.09^2}{2 \times 9.81} \right) - \left( 6 + \frac{2.26^2}{2 \times 9.81} \right)$$

$$= (30 + 1.32) - (6 + .26) = 31.32 - 6.26 = 25.06 \text{ m.}$$

Substituting the value of ' $H_m$ ' in equation (i), we get

$$\eta_o = .02424 \times 25.06 = 0.6074 = \mathbf{60.74\%}.$$

(iii) **Manometric efficiency of the pump ( $\eta_{man}$ ).**

Tangential velocity at outlet is given by

$$u_2 = \frac{\pi D_2 \times N}{60} = \frac{\pi \times 0.4 \times 1000}{60} = 20.94 \text{ m/s.}$$

From outlet velocity triangle, we have

$$\tan \phi = \frac{V_{f_2}}{u_2 - V_{w_2}} = \frac{2.0}{20.94 - V_{w_2}}$$

$$\therefore 20.94 - V_{w_2} = \frac{2.0}{\tan \phi} = \frac{2.0}{\tan 45} = 2.0$$

$$\therefore V_{w_2} = 20.94 - 2.0 = 18.94.$$

$$\eta_{man} = \frac{gH_m}{V_{w_2} u_2} = \frac{9.81 \times 25.06}{18.94 \times 20.94} = 0.6198 = \mathbf{61.98\%}.$$

## MULTISTAGE CENTRIFUGAL PUMPS

If a centrifugal pump consists of two or more impellers, the pump is called a multistage centrifugal pump. The impellers may be mounted on the same shaft or on different shafts. A multistage pump is having the following two important functions :

1. To produce a high head, and
2. To discharge a large quantity of liquid.

If a high head is to be developed, the impellers are connected in series (or on the same shaft) while for discharging large quantity of liquid, the impellers (or pumps) are connected in parallel.

### Multistage Centrifugal Pumps for High Heads.

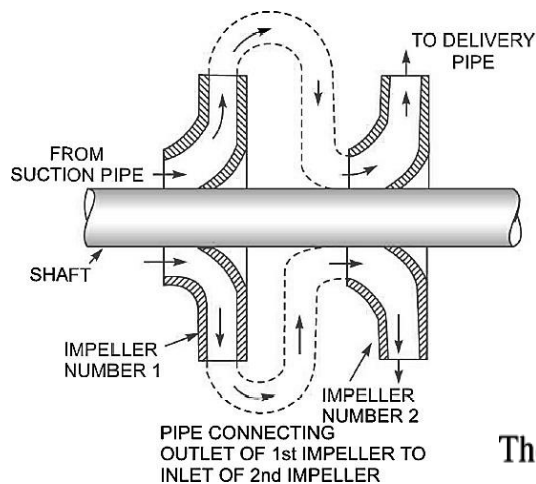

Then total head developed

$$= n \times H_m$$

The discharge passing through each impeller is same

$n$  = Number of identical impellers mounted on the same shaft,

$H_m$  = Head developed by each impeller.

## Multistage Centrifugal Pumps for High Discharge.

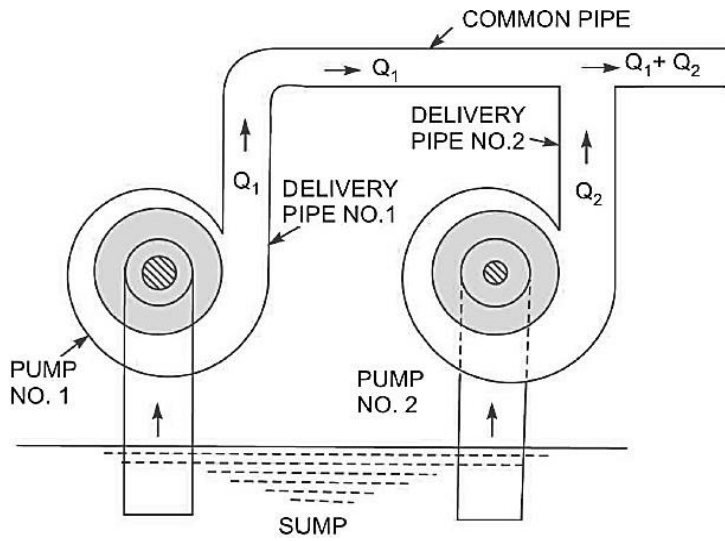

Let  $n$  = Number of identical pumps arranged in parallel.  
 $Q$  = Discharge from one pump.  
 $\therefore$  Total discharge =  $n \times Q$

## CHARACTERISTIC CURVES OF CENTRIFUGAL PUMPS

### Main Characteristic Curves.

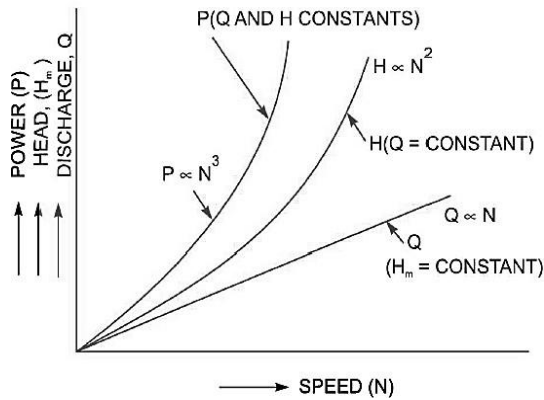

### Operating Characteristic Curves.

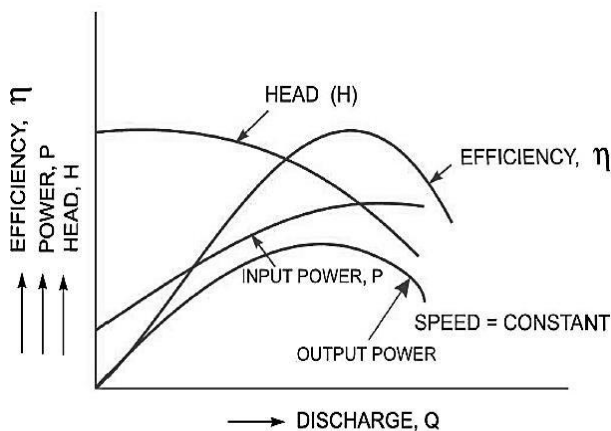



## Constant Efficiency Curves.

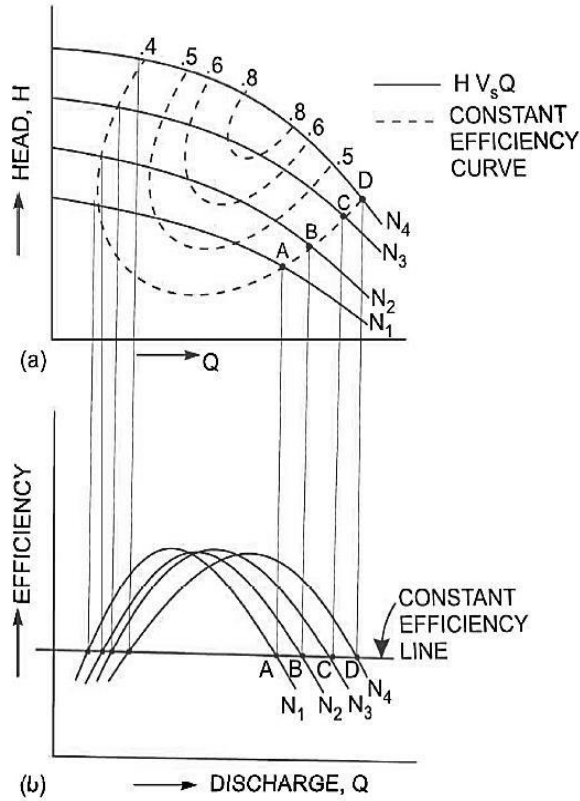

## MAXIMUM SUCTION LIFT (or SUCTION HEIGHT)

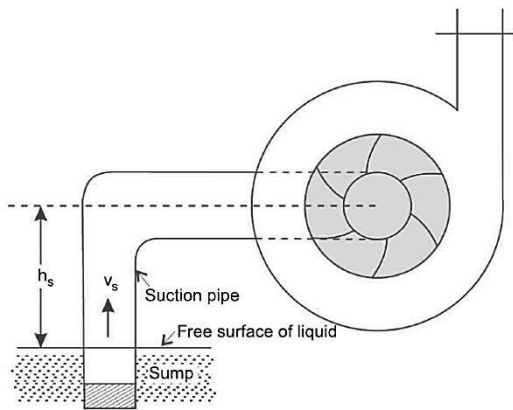

Applying Bernoulli's equation at the free surface of liquid in the sump and section 1 in the suction pipe just at the inlet of the pump and taking the free surface of liquid as datum line, we get

$$\frac{p_a}{\rho g} + \frac{V_a^2}{2g} + Z_a = \frac{p_1}{\rho g} + \frac{V_1^2}{2g} + Z_1 + h_L \quad \dots(i)$$

$$\frac{p_a}{\rho g} + 0 + 0 = \frac{p_1}{\rho g} + \frac{v_s^2}{2g} + h_s + h_{fs}$$

$$\frac{p_a}{\rho g} = \frac{p_1}{\rho g} + \frac{v_s^2}{2g} + h_s + h_{fs}$$

$$\frac{p_1}{\rho g} = \frac{p_a}{\rho g} - \left( \frac{v_s^2}{2g} + h_s + h_{fs} \right) \quad \dots(ii)$$

For finding the maximum suction lift, the pressure at the inlet of the pump should not be less than the vapour pressure of the liquid. Hence for the limiting case, taking the pressure at the inlet of pump equal to vapour pressure of the liquid, we get

$p_1 = p_v$ , where  $p_v =$  vapour pressure of the liquid in absolute units.

Now the equation (ii) becomes as

$$\frac{p_v}{\rho g} = \frac{p_a}{\rho g} - \left( \frac{v_s^2}{2g} + h_s + h_{f_s} \right)$$

$$\frac{p_a}{\rho g} = \frac{p_v}{\rho g} + \frac{v_s^2}{2g} + h_s + h_{f_s} \quad (\because p_1 = p_v) \dots(iii)$$

$$\frac{p_a}{\rho g} = \text{Atmospheric pressure head} = H_a \text{ (meter of liquid)}$$

$$\frac{p_v}{\rho g} = \text{Vapour pressure head} = H_v \text{ (meter of liquid)}$$

Now, equation (iii) becomes as

$$H_a = H_v + \frac{v_s^2}{2g} + h_s + h_{f_s}$$

$$h_s = H_a - H_v - \frac{v_s^2}{2g} - h_{f_s}$$

Equation (19.31) gives the value of maximum suction lift (or maximum suction height) for a centrifugal pump. Hence, the suction height of any pump should not be more than that given by equation (19.31). If the suction height of the pump is more, then vaporization of liquid at inlet of pump will take place and there will be a possibility of cavitation.

### NET POSITIVE SUCTION HEAD (NPSH)

The term NPSH ( Net Positive Suction Head) is very commonly used in the pump industry. Actually the minimum suction conditions are more frequently specified in terms of NPSH.

The net positive suction head (NPSH) is defined as the *absolute* pressure head at the inlet to the pump, minus the vapour pressure head ( in absolute units) plus the velocity head.

$\therefore$  NPSH = Absolute pressure head at inlet of the pump – vapour pressure head (absolute units) + velocity head

$$= \frac{p_1}{\rho g} - \frac{p_v}{\rho g} + \frac{v_s^2}{2g} \quad (\because \text{Absolute pressure at inlet of pump} = p_1)$$

the absolute pressure head at inlet of the pump is given by as

$$\begin{aligned} \frac{p_1}{\rho g} &= \frac{p_a}{\rho g} - \left( \frac{v_s^2}{2g} + h_s + h_{f_s} \right) \\ \text{NPSH} &= \left[ \frac{p_a}{\rho g} - \left( \frac{v_s^2}{2g} + h_s + h_{f_s} \right) \right] - \frac{p_v}{\rho g} + \frac{v_s^2}{2g} \\ &= \frac{p_a}{\rho g} - \frac{p_v}{\rho g} - h_s - h_{f_s} \\ &= H_a - H_v - h_s - h_{f_s} \end{aligned}$$