



SNS COLLEGE OF TECHNOLOGY

AN AUTONOMOUS INSTITUTION



Approved by AICTE New Delhi & Affiliated to Anna University Chennai
Accredited by NBA & Accredited by NAAC with A⁺⁺ Grade Recognized by UGC

DEPARTMENT OF AGRICULTURAL ENGINEERING

COURSE CODE & NAME: 19AGT301 & HEAT POWER ENGINEERING

III YEAR / V SEMESTER

UNIT : V BOILERS

Topic : Boiler Accessories



Boiler Mountings:

The necessary devices installed or mounted for the *safety* of boiler and its *control* are called boiler mountings.



Boiler Accessories:

The devices which are installed in the boiler for their *efficient operation* and *smooth working* are called Boiler Accessories.



MANHOLE



This is provided at suitable position on the boiler shell so that the man can enter into boiler shell for inspection, maintenance and repairs. This hole is usually made in elliptical shape of the size convenient for a man to enter through this hole. The opening is closed by steam tight cover.



STEAM TRAP

Steam trap is used to collect and automatically drain away the water resulted from partial condensation of steam without steam to escape with this condensate through a valve. The valve after draining the condensate is closed. It prevents the leakage of steam from the trap.



ANTIPRIMING PIPE

It is attached below the stop valve to avoid the water particles being carried away along with steam. It has closed pipe with closed ends of 1m and 2m length. The top side of the pipe has perforations. When the steam passes through it, due to inertia effect, the moisture of steam falls into the pipe and the steam with reduced moisture passes into the stop valve.



BOILER ACCESSORIES

The devices used to improve the performance and operation of the boilers are called boiler accessories. Main accessories used are:



BOILER ACCESSORIES

- **WATER HEATING DEVICES**

(UPTU- Dec 05)

Used to heat the feed water before it is fed to boiler with the help of steam of a steam engine.

Heating of feed water can be carried out either by:

1. Open Heater- Direct mixing
2. Closed heater- Indirect convection

WATER FEEDING DEVICES

Used to supply water while the boiler is in operation. These devices include the use of feed pumps either reciprocating type or centrifugal type.



INJECTOR

(UPTU-Dec 04, Dec 05, Dec o6)

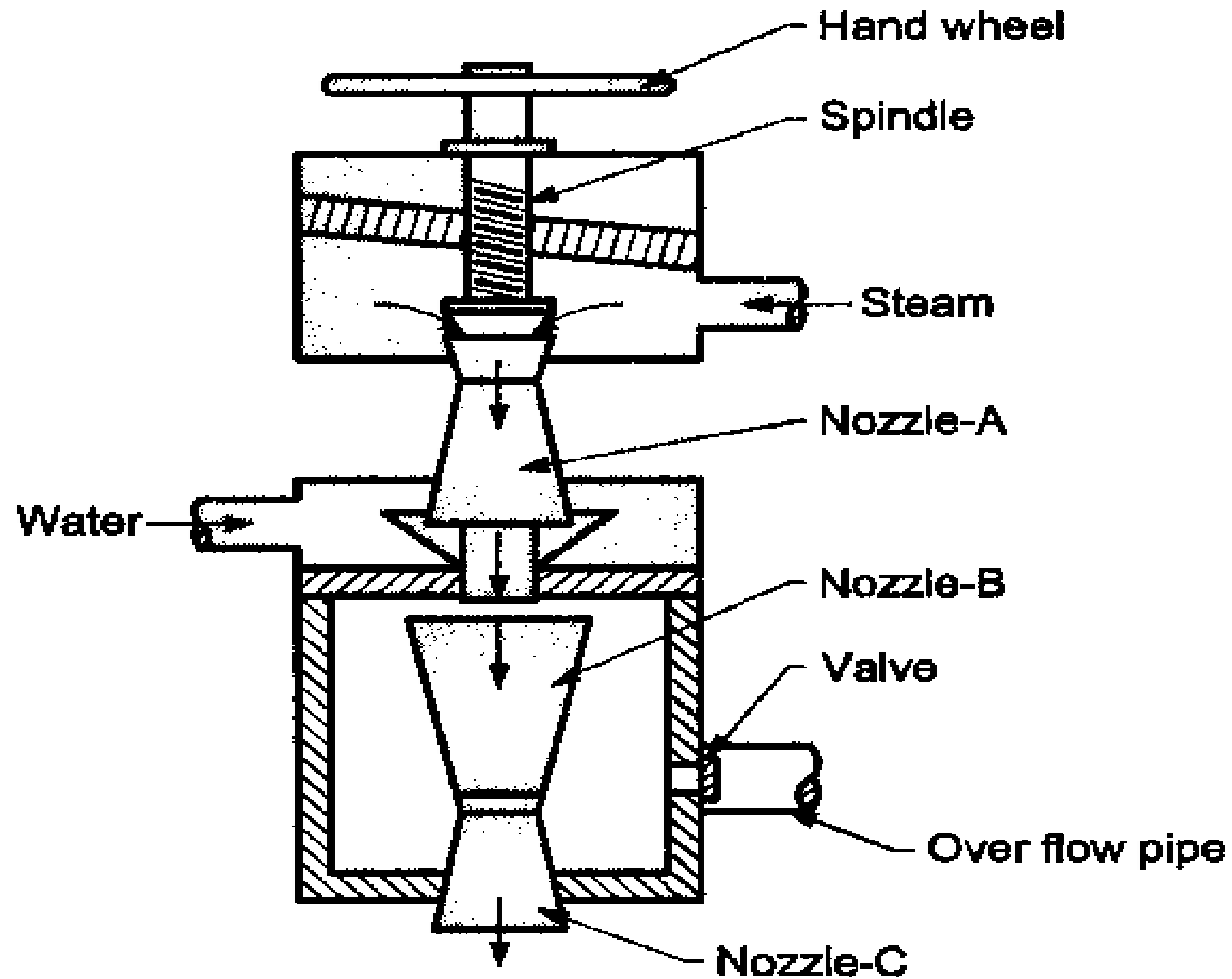



SUPER HEATERS

(UPTU-Dec 04, Dec 05, Dec 06)

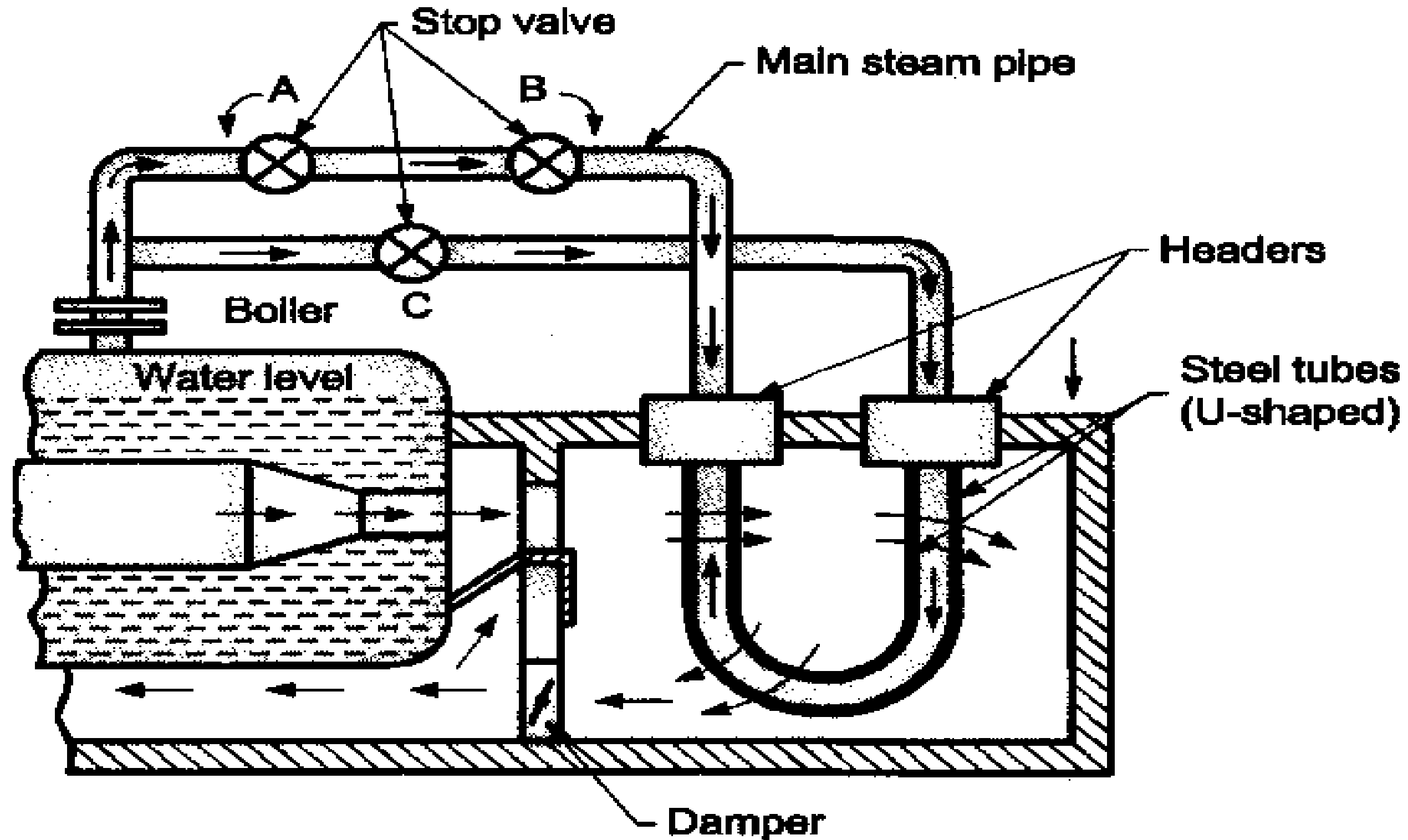



ECONOMISER

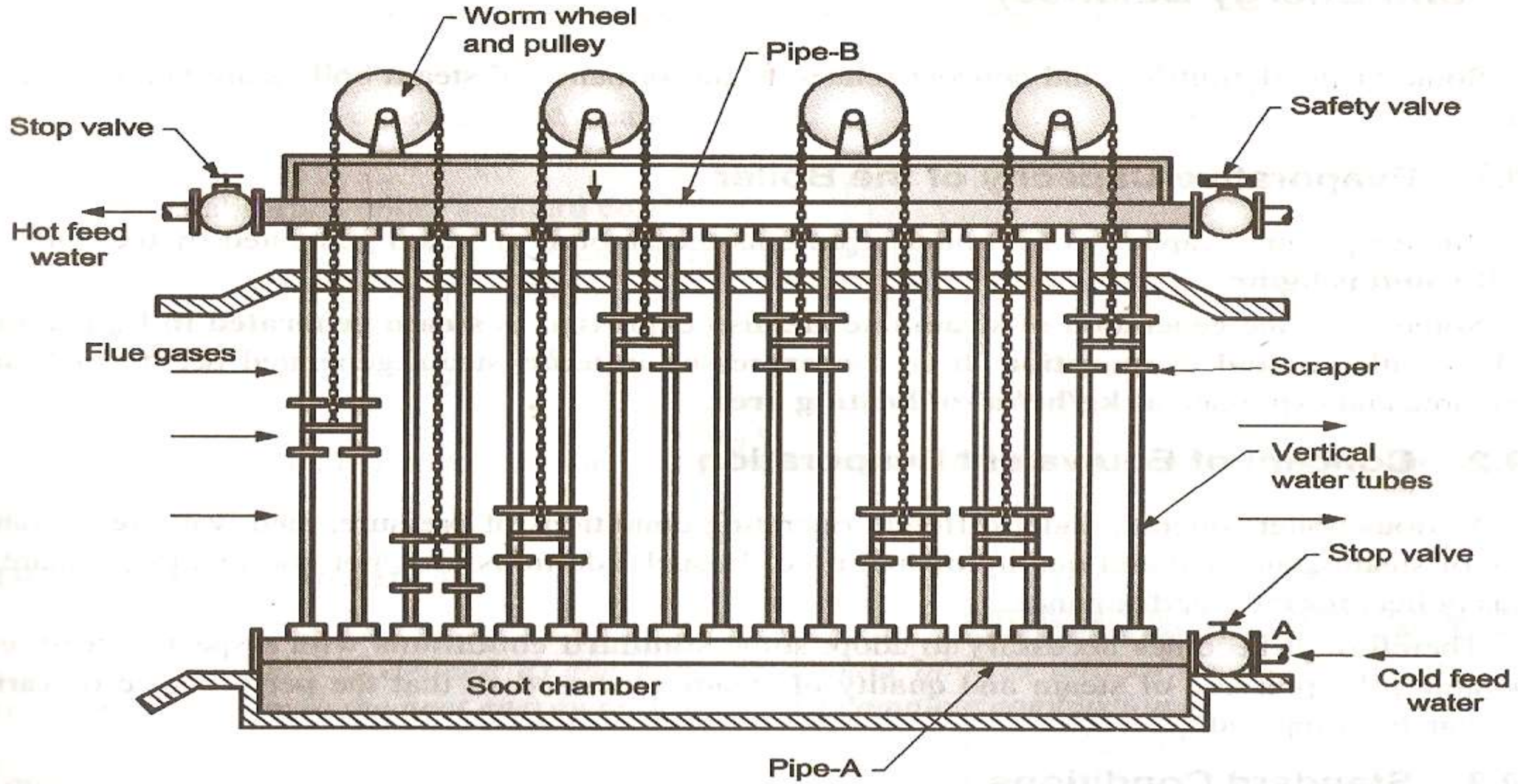



AIR PREHEATER

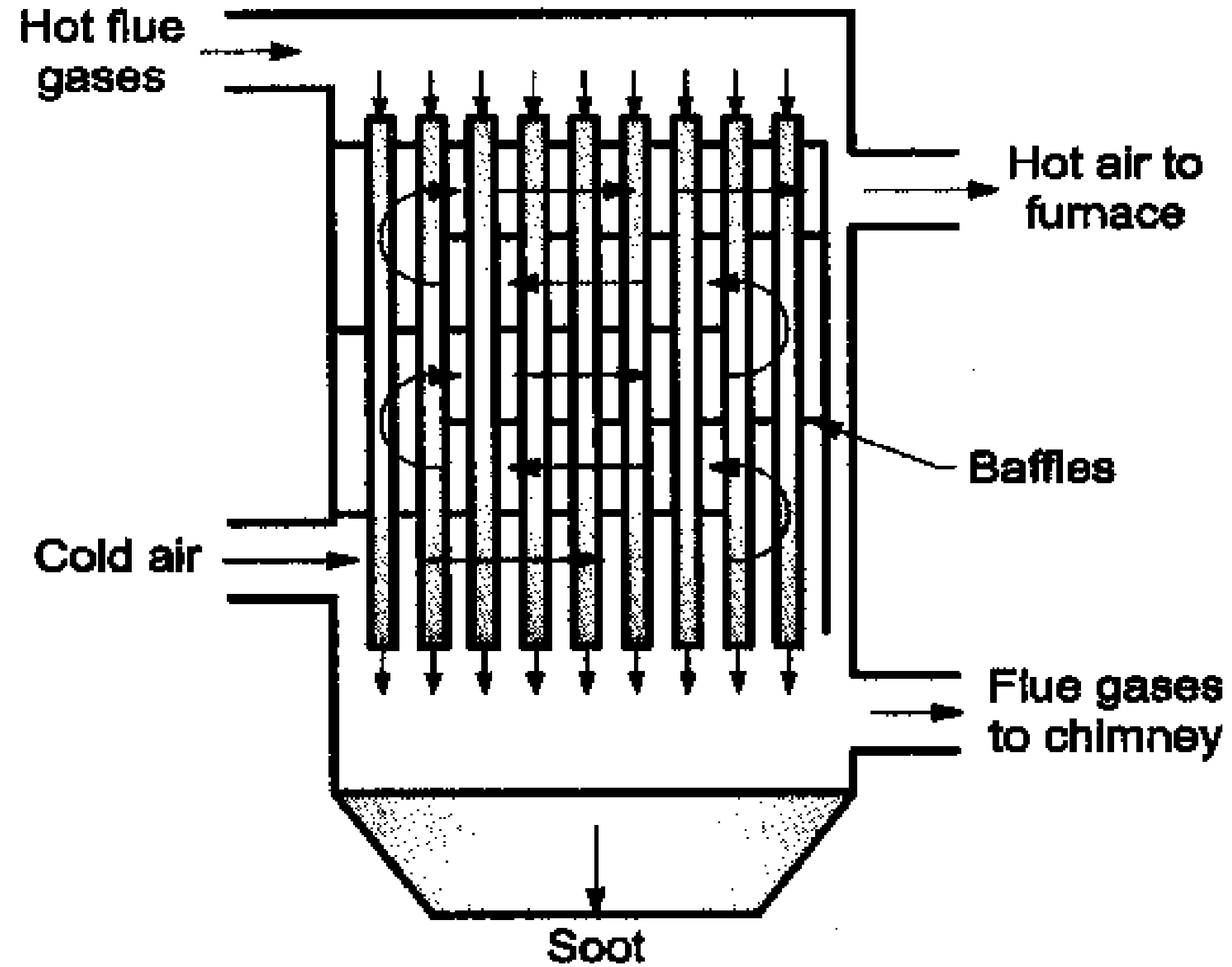



Thank You