



# **SNS COLLEGE OF TECHNOLOGY**



**AN AUTONOMOUS INSTITUTION**

**Approved by AICTE New Delhi & Affiliated to Anna University Chennai  
Accredited by NBA & Accredited by NAAC with “A++” Grade, Recognized by UGC**

**COIMBATORE**

## **DEPARTMENT OF CIVIL ENGINEERING**

**23GET102 – BASIC CIVIL AND MECHANICAL ENGINEERING**

**I YEAR / I SEMESTER**

**Unit 1 : Civil Engineering Materials and Surveying**

**Topic : Manufacturing of Clay Bricks**



# Manufacturing of Bricks

- The process of manufacturing of bricks from clay involves preparation of clay, molding and then drying and burning of bricks.
- The bricks are building materials which are generally available as rectangular blocks.
- The bricks do not require any dressing and brick laying is very simple compared to stone masonry.



# Site Selection of Manufacturing of Bricks

For the manufacturing of bricks, the site should be selected based on some important considerations such as:

- The ground should be of plain surface.
- The site should be connected with communicating roads for transporting materials etc.,
- Good brick earth should be easily available.
- The site should offer all facilities to the workers.



# Composition of Clay Bricks

Ingredient	Percentage in brick
<b>Silica (<math>\text{SiO}_2</math>)</b>	55%
<b>Alumina (<math>\text{Al}_2\text{O}_3</math>)</b>	30%
<b>Iron Oxide (<math>\text{Fe}_2\text{O}_3</math>)</b>	8%
<b>Magnesia (<math>\text{MgO}</math>)</b>	5%
<b>Lime(<math>\text{CaO}</math>)</b>	1%
<b>Organic Matter</b>	1%



# Manufacturing Process of Bricks

- There are four different operations are involved in the process of manufacturing of bricks:
  1. Preparation of clay
  2. Molding
  3. Drying
  4. Burning



# Preparation of Clay

**The clay for bricks is prepared in the following order:**

- ❖ Un-soiling
- ❖ Digging
- ❖ Cleaning
- ❖ Weathering
- ❖ Blending
- ❖ Tempering



# Preparation of Clay

## (i) Un-Soiling of clay:

- We need pure clay for the preparation of bricks.
- The top layer of soil may contains impurities, so the clay in top layer of soil about 200mm depth is thrown away. This is called unsoiling.

## (ii) Digging:

- The clay is then dug out from the ground.
- It is spread on the levelled ground, just a little deeper than the general level of ground.
- The height of heaps of clay is about 600 mm to 1200 mm.



# Preparation of Clay

## (iii) Cleaning:

- In this stage, the clay is cleaned of stones, vegetable matter etc. if large quantity of particulate matter is present, then the clay is washed and screened.
- The lumps of clay are converted into powder with earth crushing rollers.

## (iv) Weathering:

- The cleaned clay is exposed to atmosphere for softening.
- The period of weathering may be 3 to 4 weeks or a full rainy season.
- Generally, the clay is dug out just before the rainy season for larger projects.





# Preparation of Clay

## (v) Blending:

- If we want to add any ingredient to the clay, it is to be added in this stage by making the clay loose and spread the ingredient over it.
- Then take small portion of clay into the hands and turning it up and down in vertical direction. This process is called blending of clay.



# Preparation of Clay

## (vi) Tempering:

- In this stage, water is added to clay and pressed or mixed.
- The pressing will be done by cattle or with feet of men for small scale projects, pug mill is used as grinder for large scale projects.
- So, the clay obtains the plastic nature and now it is suitable for molding.



# Pug Mill

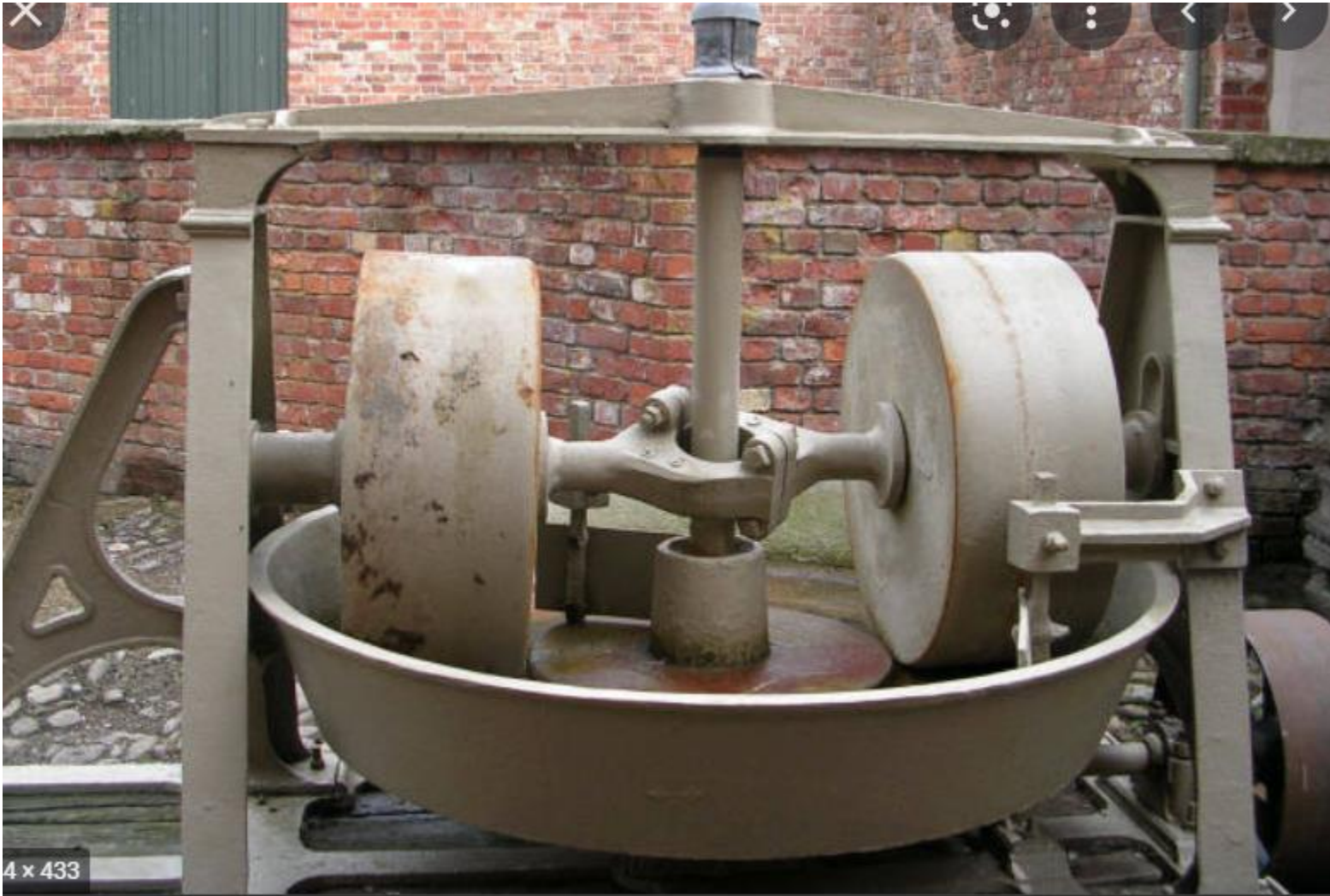



# Preparation of Clay

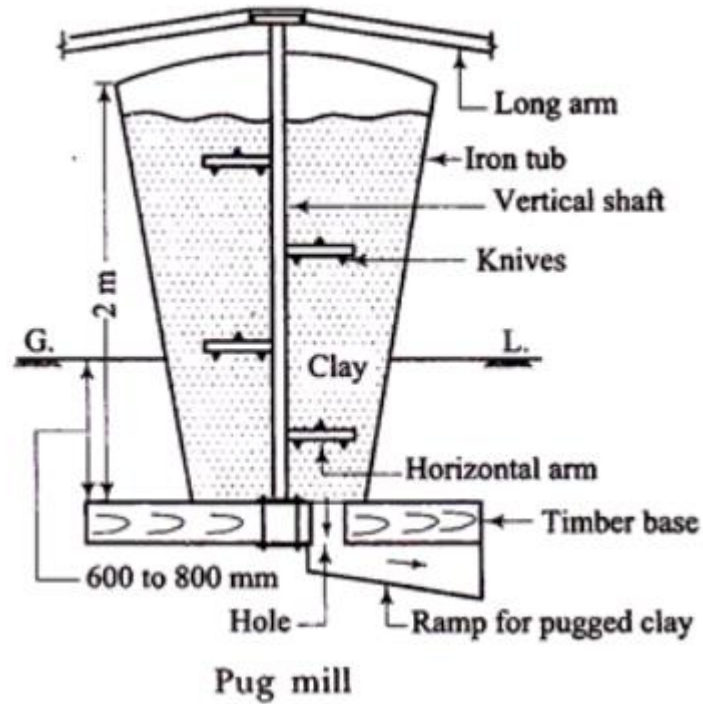



# Preparation of Clay







# Preparation of Clay





# Molding of Clay

In the molding process, prepared clay is mold into brick shape (generally rectangular). This process can be done in two ways according to scale of project.

1. Hand molding ( for small scale)
2. Machine molding ( for large scale)



# Molding of Clay

## Hand molding of bricks

- If manufacturing of bricks is on a small scale and manpower is also cheap then we can go for hand molding.
- The molds are in rectangular shape made of wood or steel which are opened at the top and bottom.
- If we take durability in consideration steel molds are better than wooden molds.

In hand molding again there are two types and they are

1. Ground molded bricks
2. Table-molded bricks





# Molding of Clay





# Molding of Clay

## Ground molded bricks:

- In this process of ground molding, first level the ground and sand or ash is sprinkled over it.
- Now place the wet mold in the ground and filled it with tempered clay and press hard to fill all corners of the mold. Extra clay is removed with metal strike or wood strike or with wire.
- The mold is then lifted up and we have raw brick in the ground. And again wet the mold by dipping it in water and repeat the same process. The process of dipping mold every time to make bricks is called **slop molding**.



# Molding of Clay

- Sometimes, the inside surface of mold is sprinkled with sand or ash instead of dipping in water this is called **sand molding**.
- Frog mark means the mark of depth which is placed on raw brick while molding. The depth may be 10mm to 20mm.
- Frog mark stats the trademark of manufacturing company and also it is useful to store mortar in it when the bricks is placed over it.



# Molding of Clay





# Molding of Clay

## Table molded bricks

- This process is similar to ground molding process, but here the bricks are molded on the table of size 2m x 1m.
- Ground molding is economical when compared to table molding.



# Molding of Clay

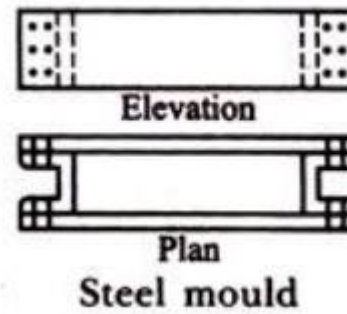
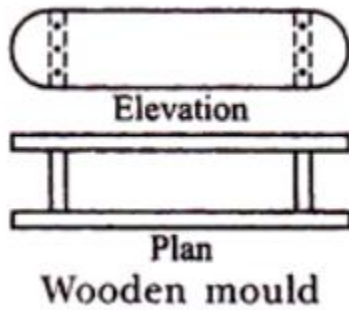



# Molding of Clay

## Machine molding of bricks

The bricks required are in large quantity, then machine molding is economical and also saves more time. Here also we are having two types of machines,

1. Plastic clay machines
2. Dry clay machines



# Molding of Clay

## Plastic clay machines

- This machines contain an opening in rectangular shape and when we place the tempered clay in to this machine it will come out through this opening.
- Now, the rectangular strips coming out the opening are cut by wires to get required thickness of brick.
- So, these are also called **wire cut bricks**. Now these raw bricks are ready for the drying process.





# Molding of Clay

## Dry clay machines

- Dry clay machines are more time saving machines.
- We can put the blended clay into these machines directly without tempering.
- Means tempering is also done in this machine by adding some water.
- When the required stiffness is obtained the clay is placed in mold and pressed hard and well-shaped bricks are delivered.
- These are called **pressed bricks** and these do not require drying they may directly sent to burning process.



# Molding of Clay

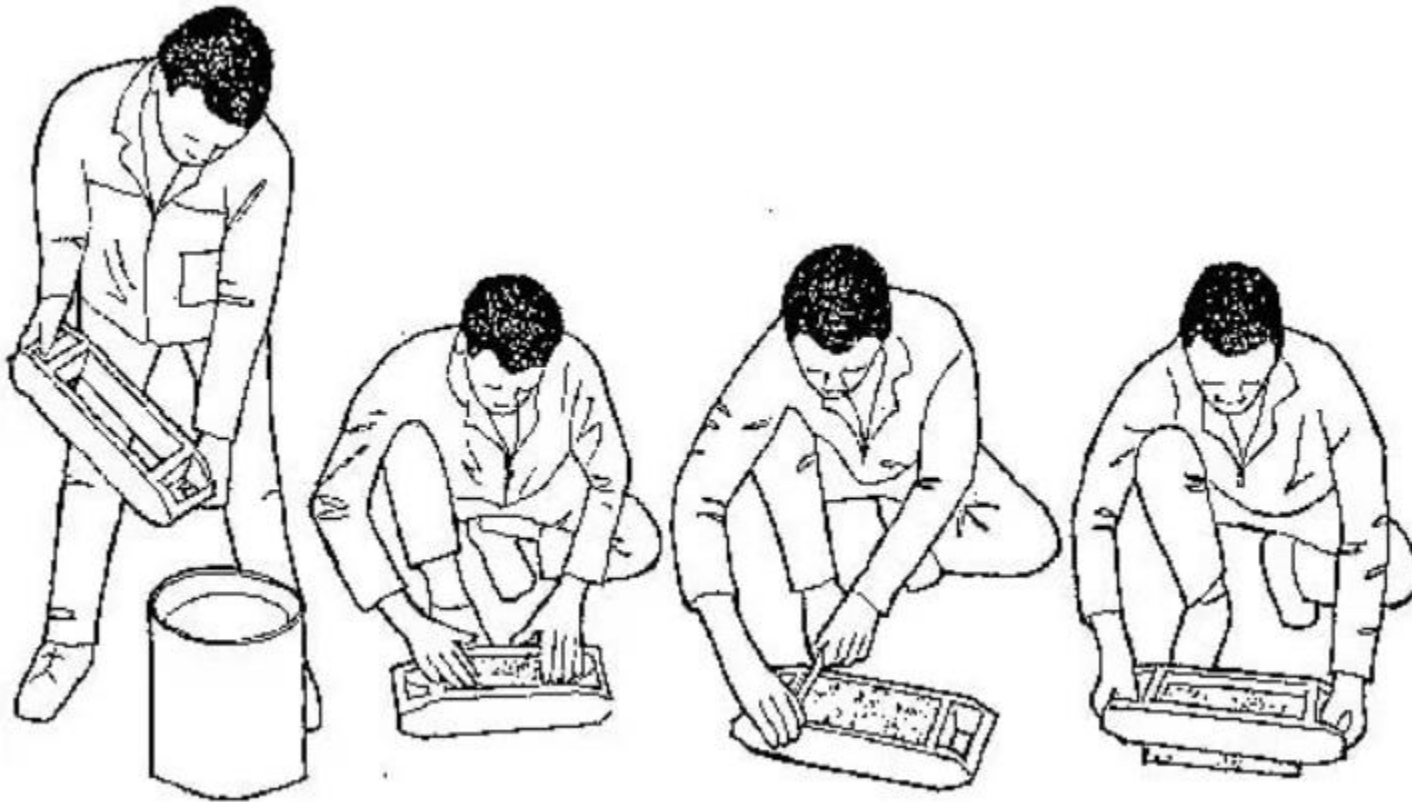



# Molding of Clay





# Drying of Raw Bricks

- After molding process the bricks contain some amount of moisture in it. So, drying is to be done otherwise they may cracked while burning. The drying of raw bricks is done by natural process.
- The bricks are laid in stacks. A stack consists 8 to 10 stairs. The bricks in these stacks should be arranged in such a way that circulation of air in between the bricks is free.
- The period of drying may be 3 to 10 days. It also depends upon the weather conditions.
- The drying yards are also prepared on higher level than the normal ground for the prevention of bricks from rain water.
- In Some situations artificial drying is adopted under special dryers or hot gases.





# Drying of Raw Bricks





# Drying of Raw Bricks

**The important facts to be remembered in connection with the drying of bricks are as follows:**

**(i) Artificial Drying:**

- The bricks are generally dried by natural process.
- But when bricks are to be rapidly dried on a large scale, the artificial drying may be adopted.
- In such a case, the moulded bricks are allowed to pass through special dryers which are in the form of tunnels or hot channels or floors.
- Such dryers are heated with the help of special furnaces or by hot flue gases.
- The tunnel dryers are more economical than hot floor dryers and they may be either periodic or continuous.
- In the former case, the bricks are filled, dried and emptied in rotation.
- In the latter case, the loading of bricks is done at one end and they are taken out at the other end.
- The temperature is usually less than 120°C and the process of drying of bricks takes about 1 to 3 days depending upon the temperature maintained in the dryer, quality of clay product, etc.



# Drying of Raw Bricks

## (ii) Circulation of Air:

- The bricks in stacks should be arranged in such a way that sufficient air space is left between them for free circulation of air.

## (iii) Drying Yard:

- For the drying purpose, special drying yards should be prepared.
- It should be slightly on a higher level and it is desirable to cover it with sand.
- Such an arrangement would prevent the accumulation of rain water.



# Drying of Raw Bricks

## (iv) Period for Drying:

- The time required by molded bricks to dry depends on prevailing weather conditions. Usually it takes about 3 to 10 days for bricks to become dry.





# Burning of Bricks

- In the process of burning, the dried bricks are burned either in clamps (small scale) or kilns (large scale) up to certain degree temperature. In this stage, the bricks will gain hardness and strength so it is important stage in manufacturing of bricks.
- The temperature required for burning is about  $1100^{\circ}\text{C}$ . If they burnt beyond this limit they will be brittle and easy to break. If they burnt under this limit, they will not gain full strength and there is a chance to absorb moisture from the atmosphere.
- Hence burning should be done properly to meet the requirements of good brick.



# Burning of Bricks





# Burning of Bricks





# Process of Brick Making

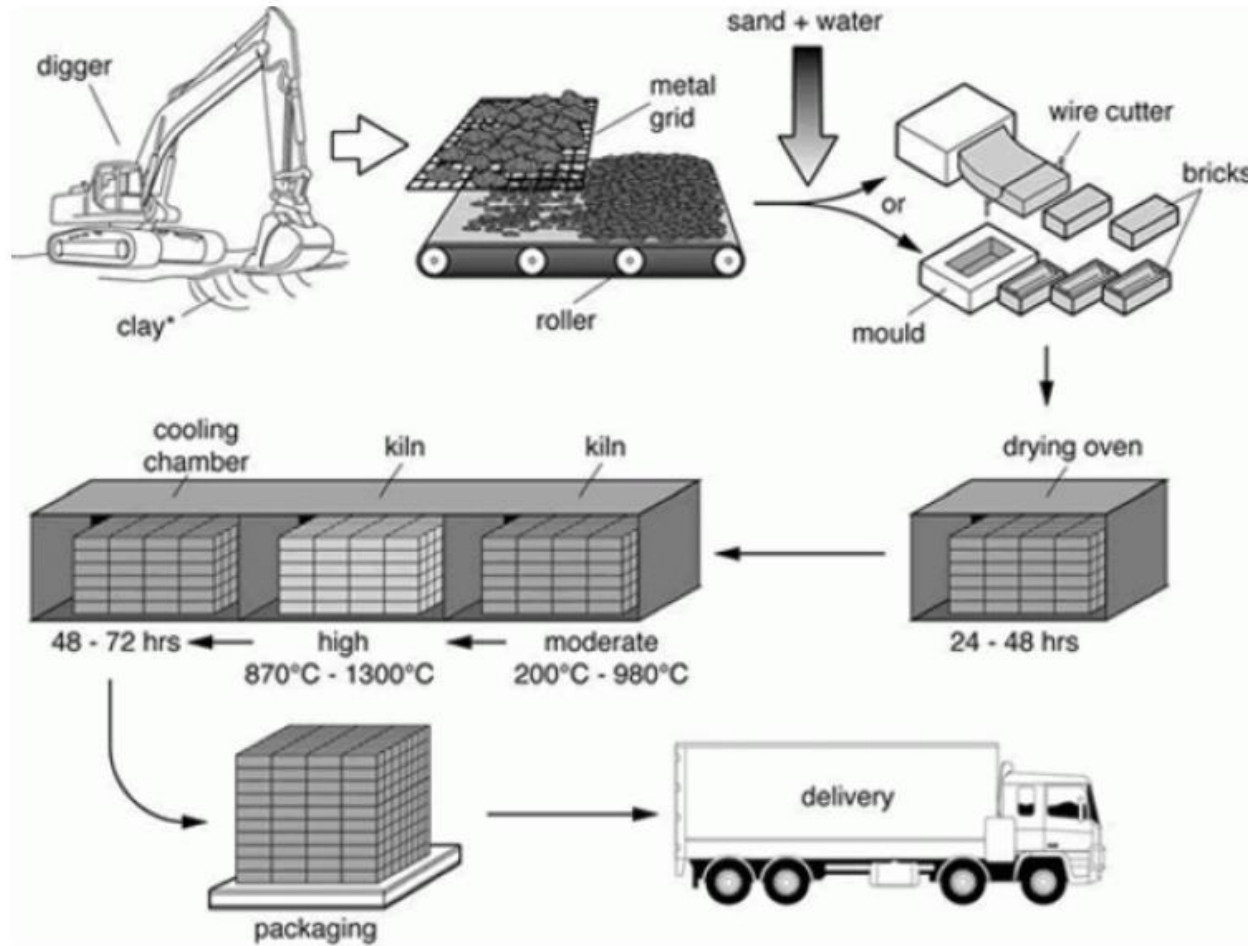

The process of brick making



***Thank You!!***