



SNS COLLEGE OF TECHNOLOGY

(An Autonomous Institution)



COIMBATORE-35

**Accredited by NBA-AICTE and Accredited by NAAC – UGC with A+ Grade
Approved by AICTE, New Delhi & Affiliated to Anna University, Chennai**

DEPARTMENT OF BIOMEDICAL ENGINEERING

COURSE NAME: 19EIB201/ ELECTRONIC DEVICES

II YEAR / III SEMESTER

Unit 1 – Transistors

Topic 2: TRIAC





TRIode for Alternating Current



- While power electronic switches like MOSFET, IGBT, etc are used for switching/controlling DC power, the TRIAC is used to control AC power because once turned on TRIAC can conduct in both the direction allowing AC voltage to pass completely in both the positive and negative cycle.
- The TRIAC is a three-terminal semiconductor switching device that is used for controlling current flow in a circuit.
- It is a bidirectional device that can pass the current in both forward and reverse direction, which means that they can conduct in both the conditions of the gate signal, positive and negative.



TRIAC

Introduction to TRIAC

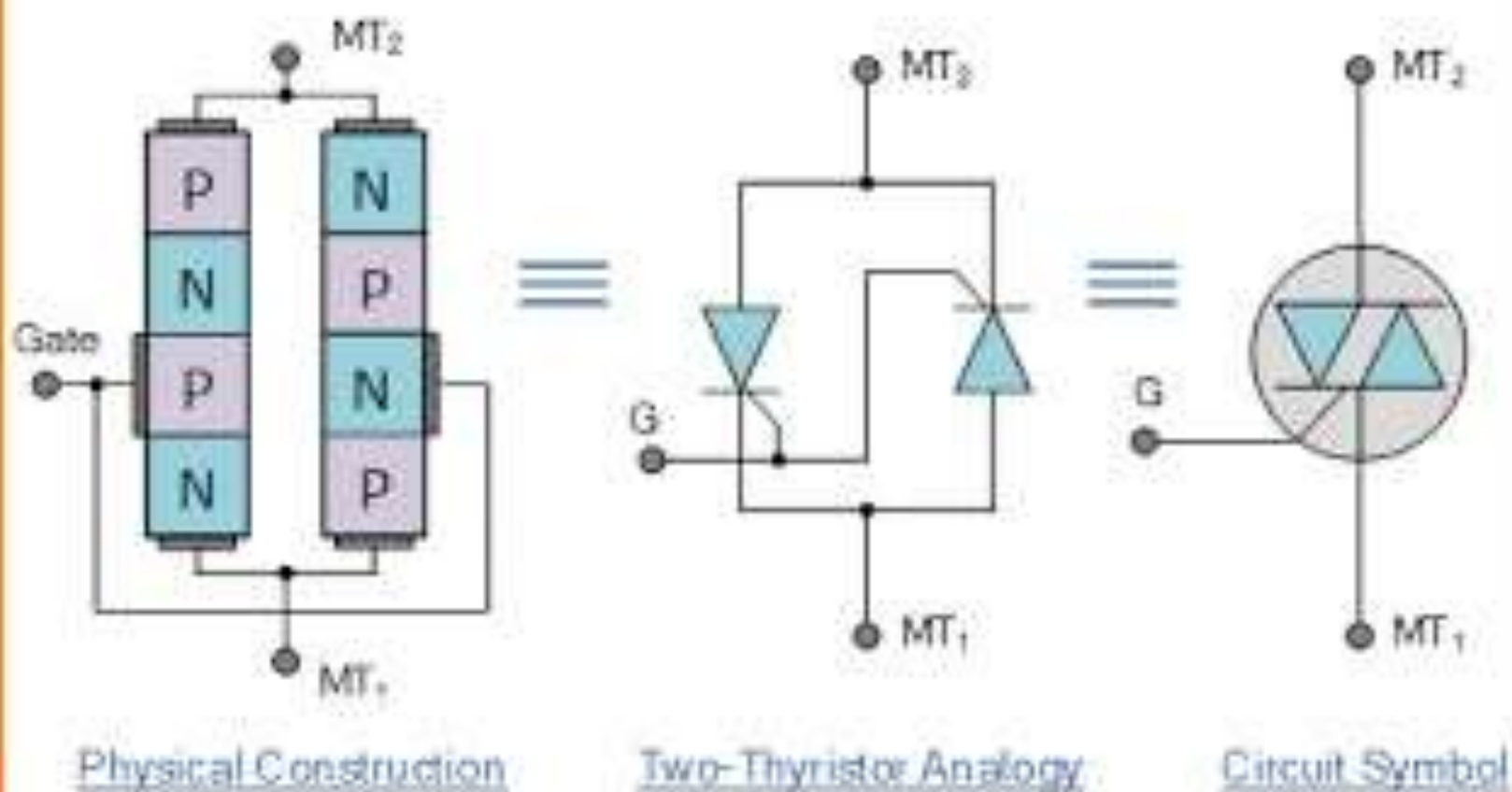

- A TRIACs can be formed by connecting two equivalent SCRs in inverse parallel to one another and the gates of the two SCR are connected together to form a single gate.
- It has three terminals Main Terminal 1 (MT1), Main Terminal 2 (MT2) and Gate (G).



Construction of TRIAC

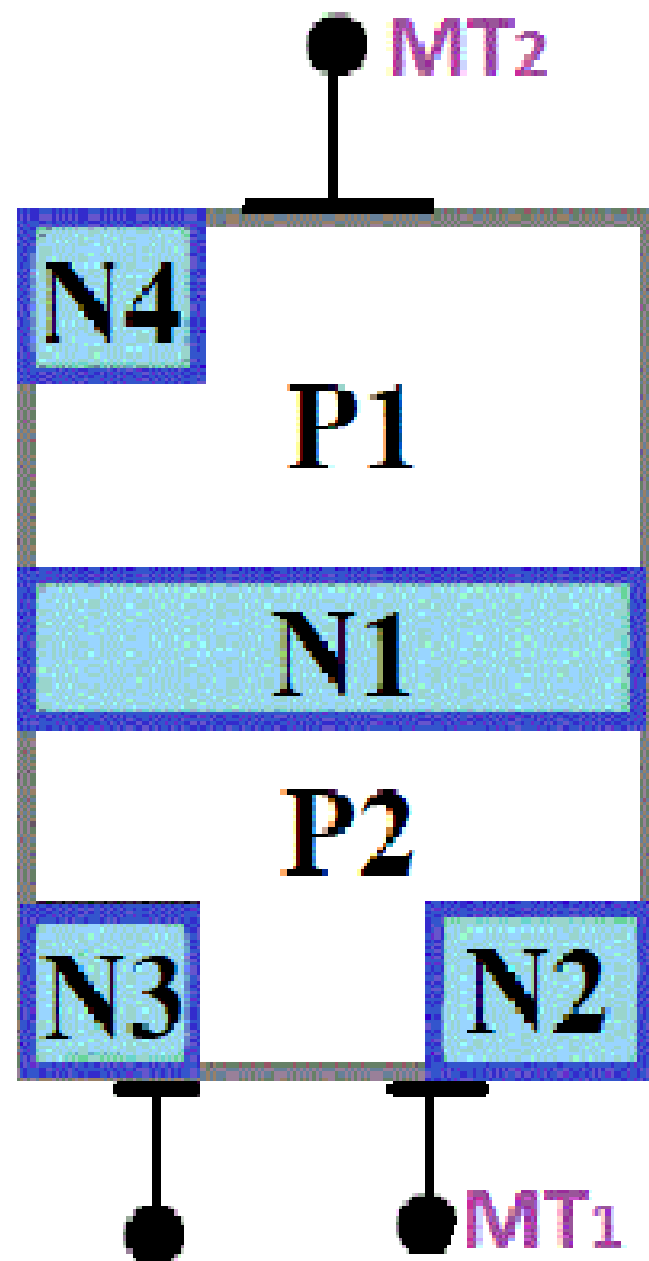

- The structure of the TRIAC, is a four-layer device that consists of six doping regions.
- The gate terminal is designed in a way to have ohmic contact with both N and P regions, which helps the device to get triggered with both positive and negative polarities.



Working of a TRIAC

TRIAC can go to conduction state if the applied voltage is equal to the breakdown voltage, but the most preferred way of turning on a TRIAC is by providing a gate pulse, either positive or negative.

- Four different types of modes of operation as listed below
 1. MT2 is positive with respect to MT1 with a gate polarity positive with respect to MT1.
 2. MT2 is positive with respect to MT1 with a gate polarity negative with respect to MT1.
 3. MT2 is negative with respect to MT1 with a gate polarity negative with respect to MT1.
 4. MT2 is negative with respect to MT1 with a gate polarity positive with respect to MT1.



Mode 1:

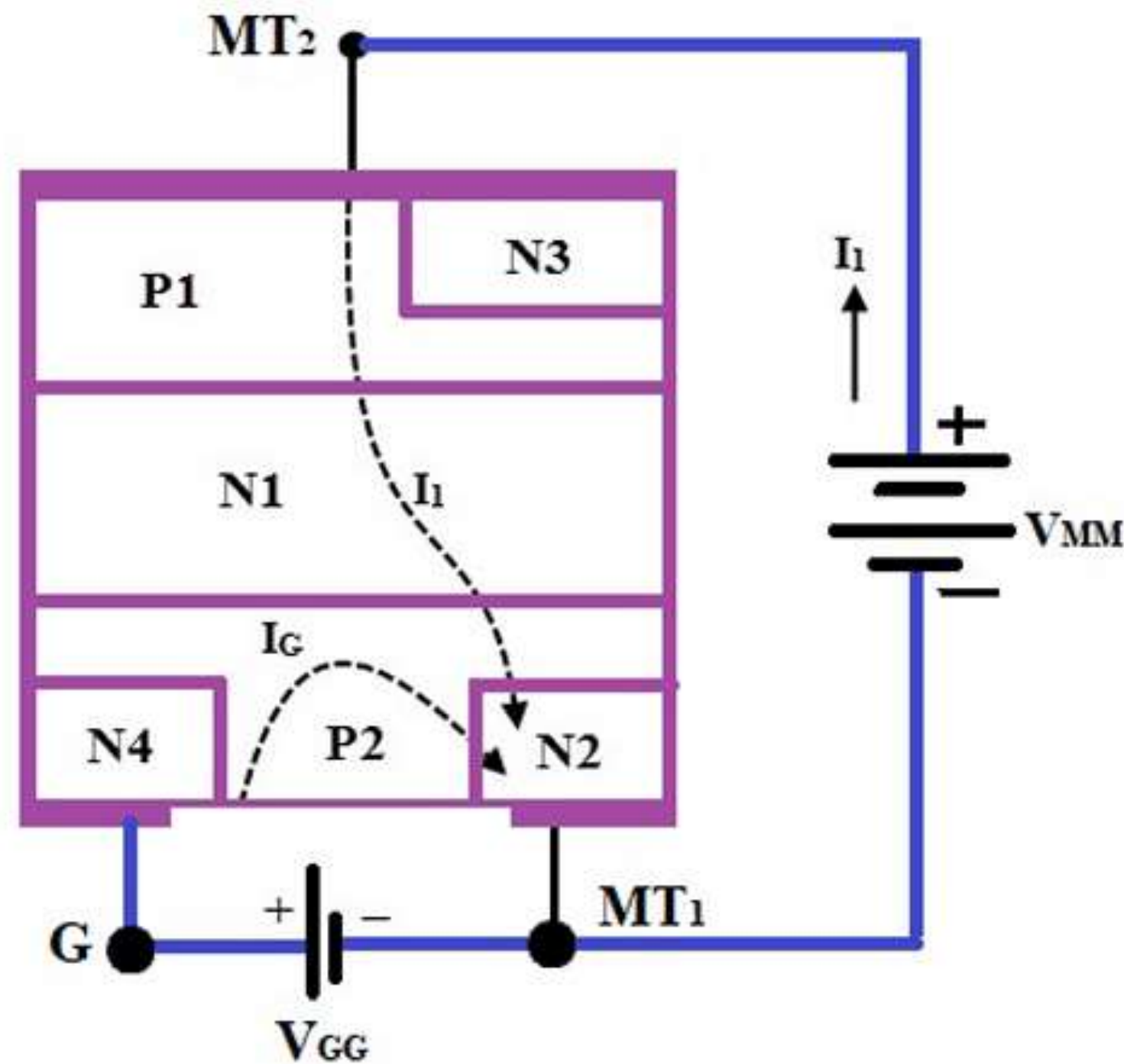

- When the terminal MT2 is positive with respect to the Terminal MT1 the current will be flowing in the path of P1-N1-P2-N2.
- During this operation, the junction between the layers P1-N1 and P2-N2 are forward biased whereas the Junction between N1-P2 is reverse biased.
- When the positive signal is applied to the gate the junction between P2-N2 is forward biased and breakdown occurs.



Mode 2:

- When the MT2 is positive and the gate pulse is negative, the current flow will be in the same path as the first mode which is P1-N1-P2-N2, but here the junction between the P2-N2 is forward biased and the current carriers are injected into the P2 layer.

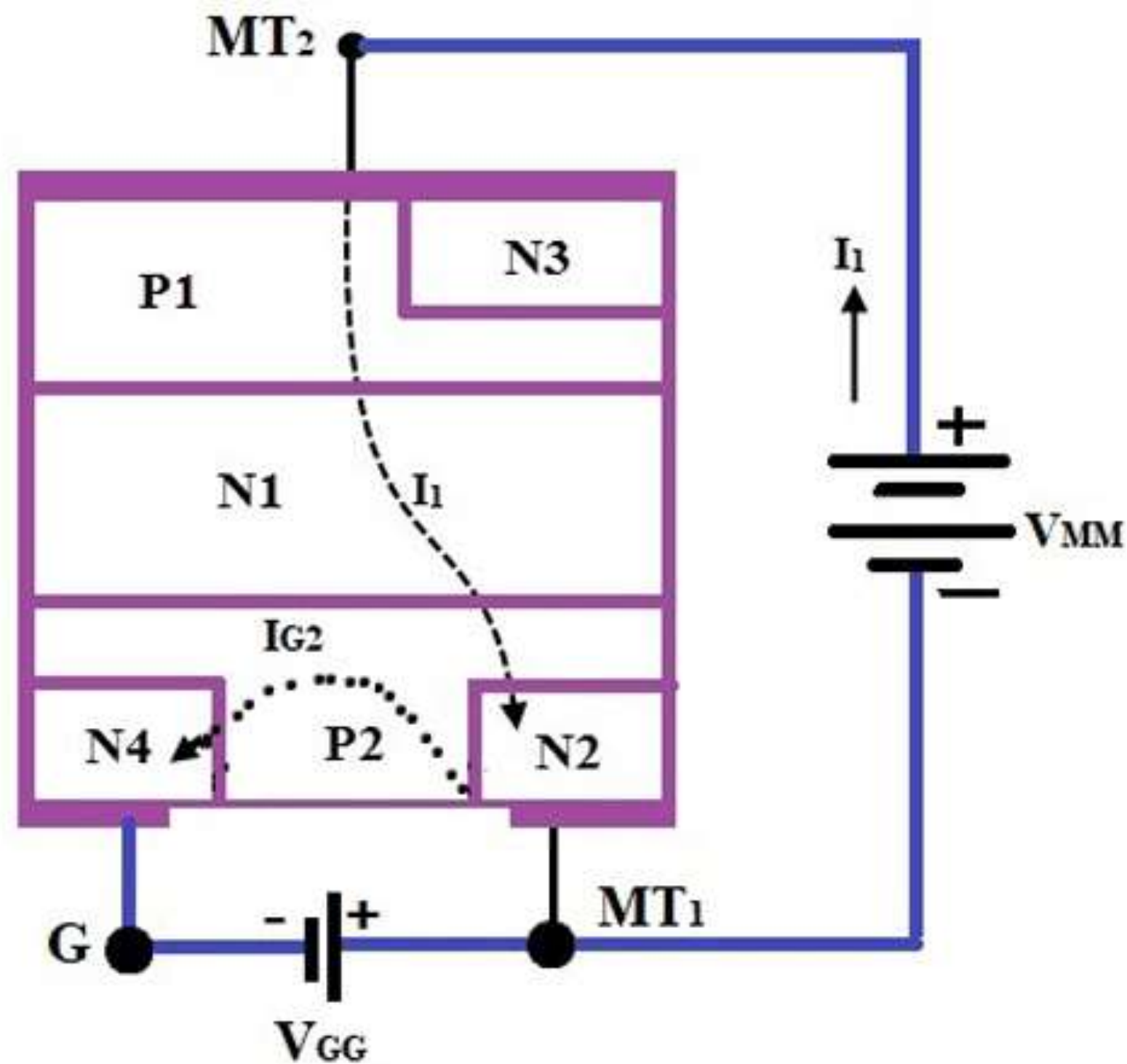



Mode 3:

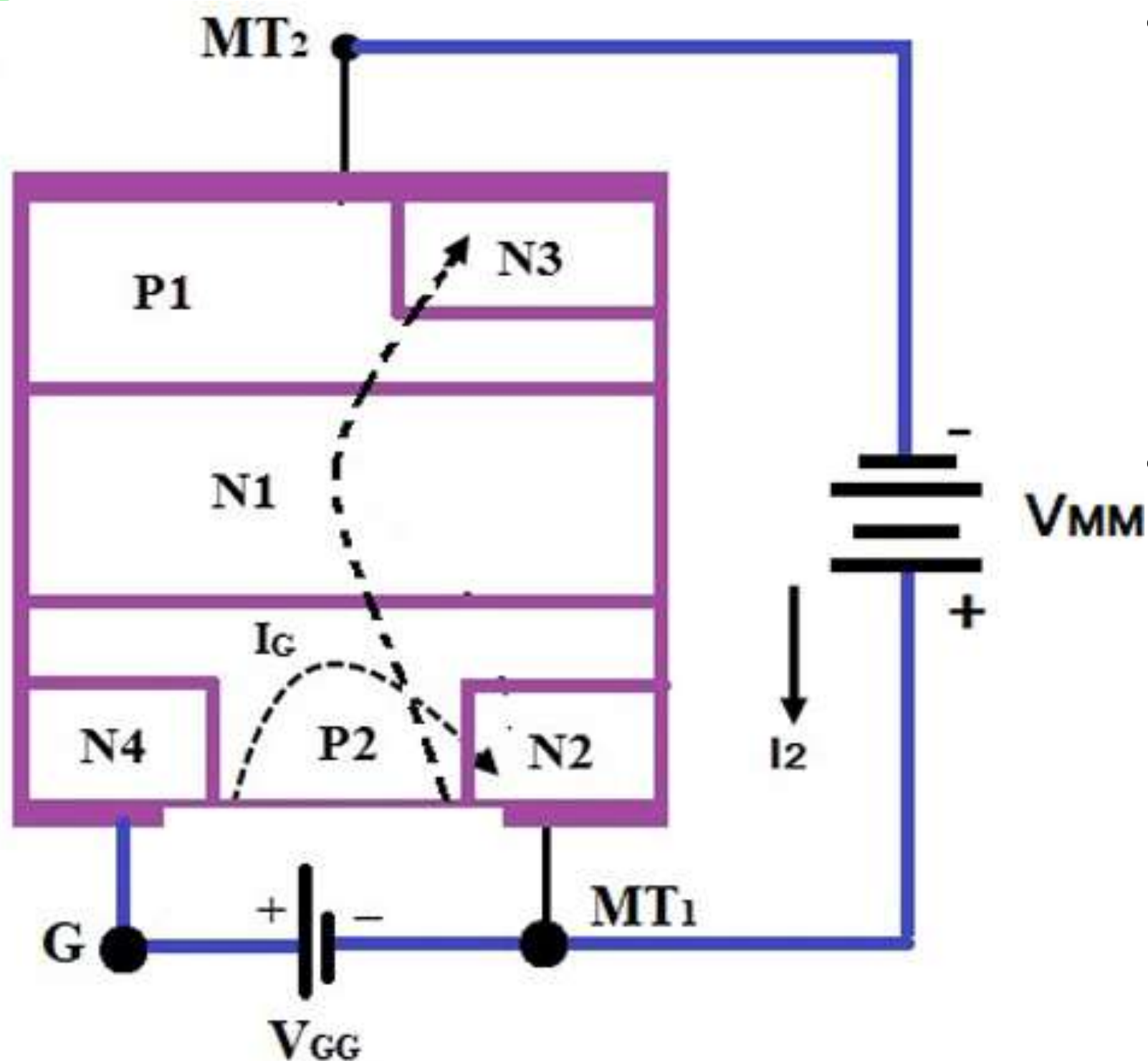

- When the terminal MT2 is positive and negative pulse is provided to the gate terminal the current will be flowing in the path of P2-N1-P2-N2.
- During the operation the junction between the layers P2-N1 and P1-N4 are forward biased whereas the junction between the layers N1-P1 is reverse biased, hence the TRIAC is said to operate in the negatively biased region.



Mode 4:

- When the terminal MT2 is negative and the gate is triggered with a positive pulse the junction between P2-N2 is forward biased and the current carriers are injected, hence the TRIAC is turned on

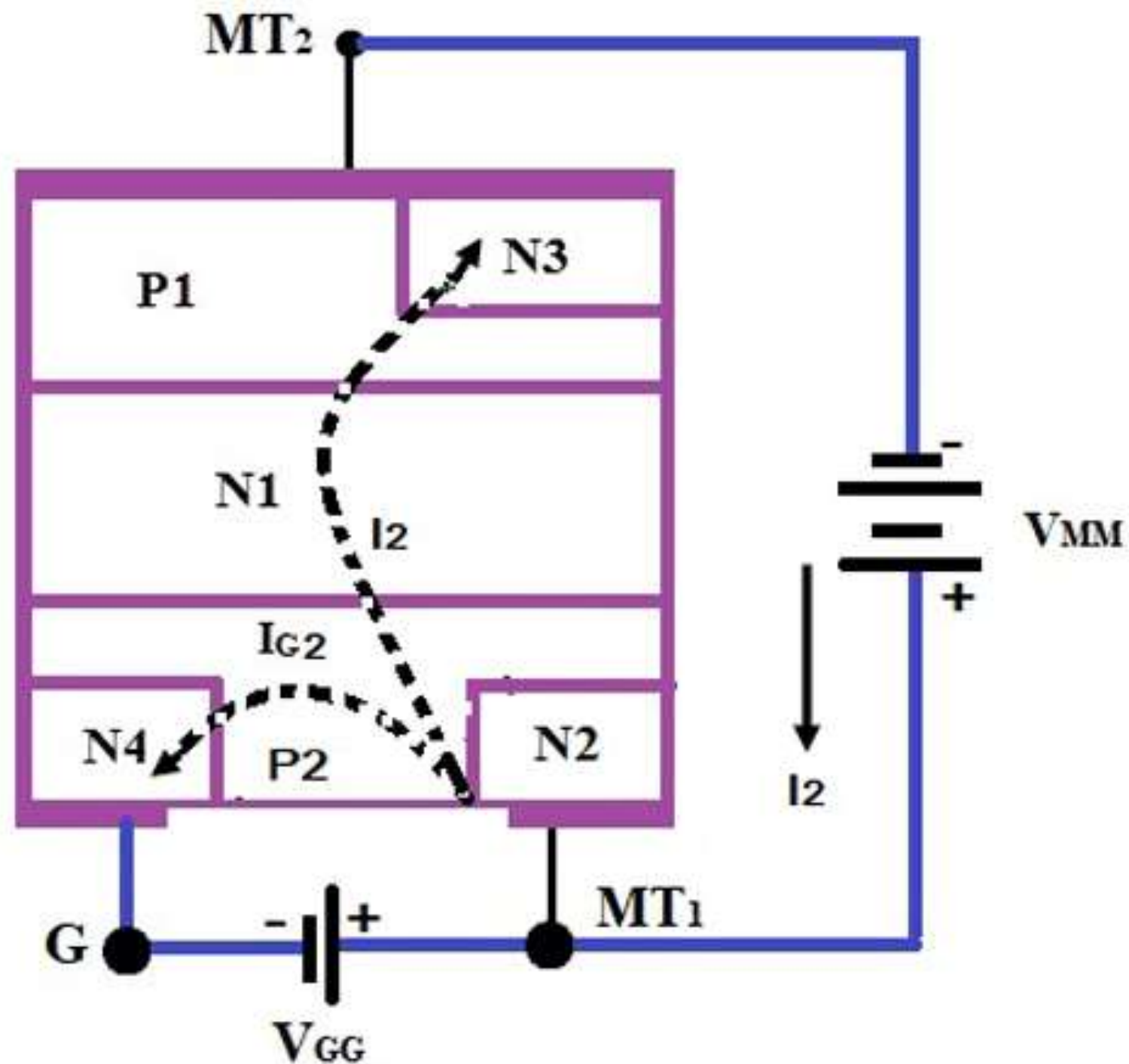



V-I Characteristics of TRIAC

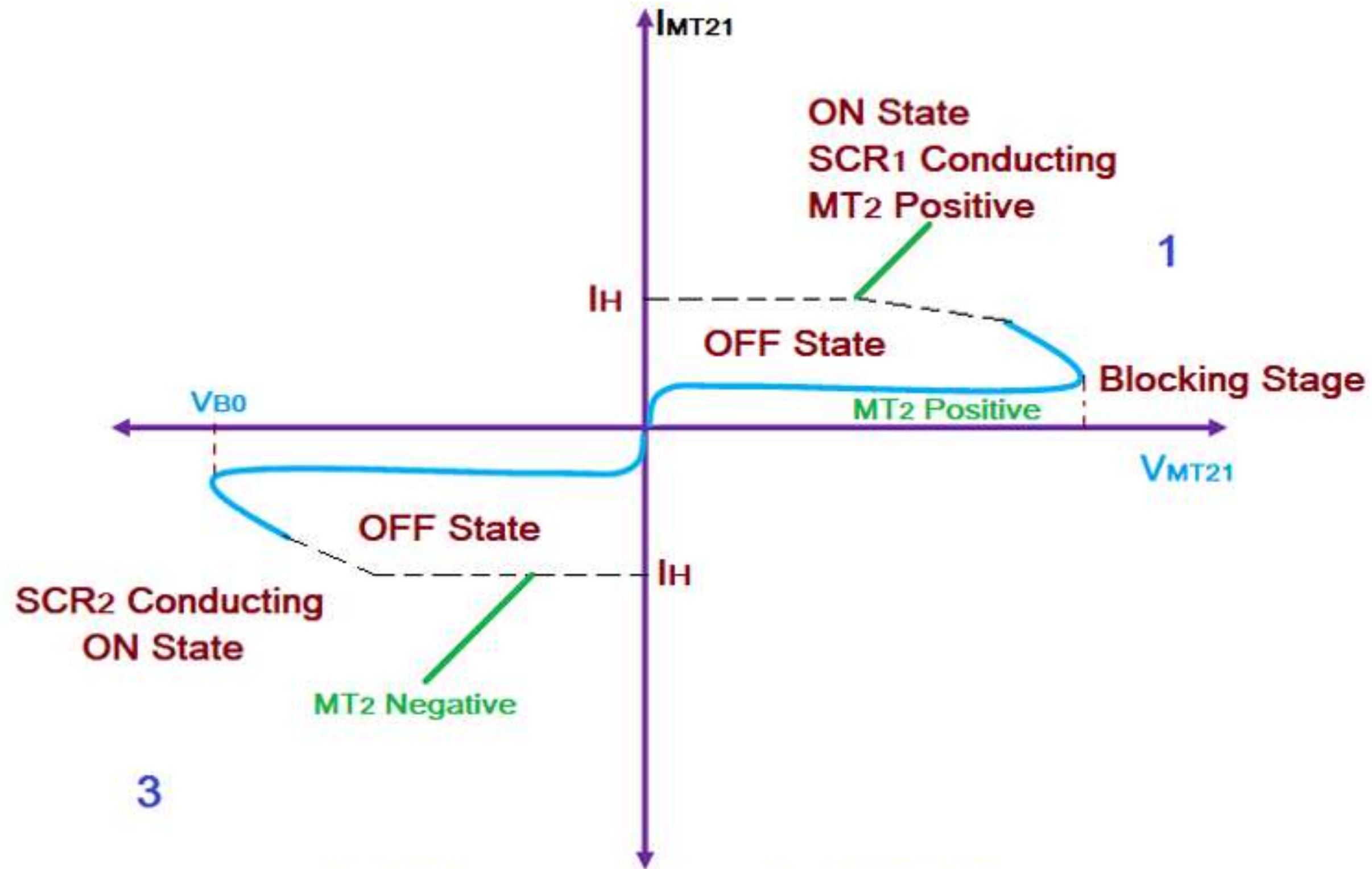

V-I Characteristics of a TRIAC



SUMMARY



ASSESSMENT

Dear student,

Quiz is posted in your Google class room

Allotted time for quiz is 5 min

No of Questions is 10





KEEP
LEARNING..
Thank u

SEE YOU IN NEXT CLASS