



**SNS COLLEGE OF TECHNOLOGY**  
**An Autonomous Institution**  
**Coimbatore-35**



Accredited by NBA – AICTE and Accredited by NAAC – UGC with 'A+' Grade  
Approved by AICTE, New Delhi & Affiliated to Anna University, Chennai

**DEPARTMENT OF ELECTRONICS & COMMUNICATION ENGINEERING**

**19ECB301-ANALOG AND DIGITAL COMMUNICATION**

III YEAR/ V SEMESTER

**UNIT 4 – DIGITAL MODULATION TECHNIQUES**

**TOPIC – Modulation techniques**



## OUTLINE



**Digital Introduction to digital modulation**

**Relevant modulation schemes**

**Geometric representations**

**Coherent & Non-Coherent Detection**

**Modulation spectra**



# Digital To Analog Conversion

- **Digital-to-analog** conversion is the process of changing one of the characteristics of an analog signal based on the information in digital data.
- **Topics discussed in this section:**
  1. Aspects of Digital-to-Analog Conversion
  2. Amplitude Shift Keying
  3. Frequency Shift Keying
  4. Phase Shift Keying
  5. Quadrature Amplitude Modulation



# Digital-to-analog conversion



- Digital-to-analog conversion is the process of changing one of the characteristics of an analog signal (**carrier signal**) based on the information in digital data.

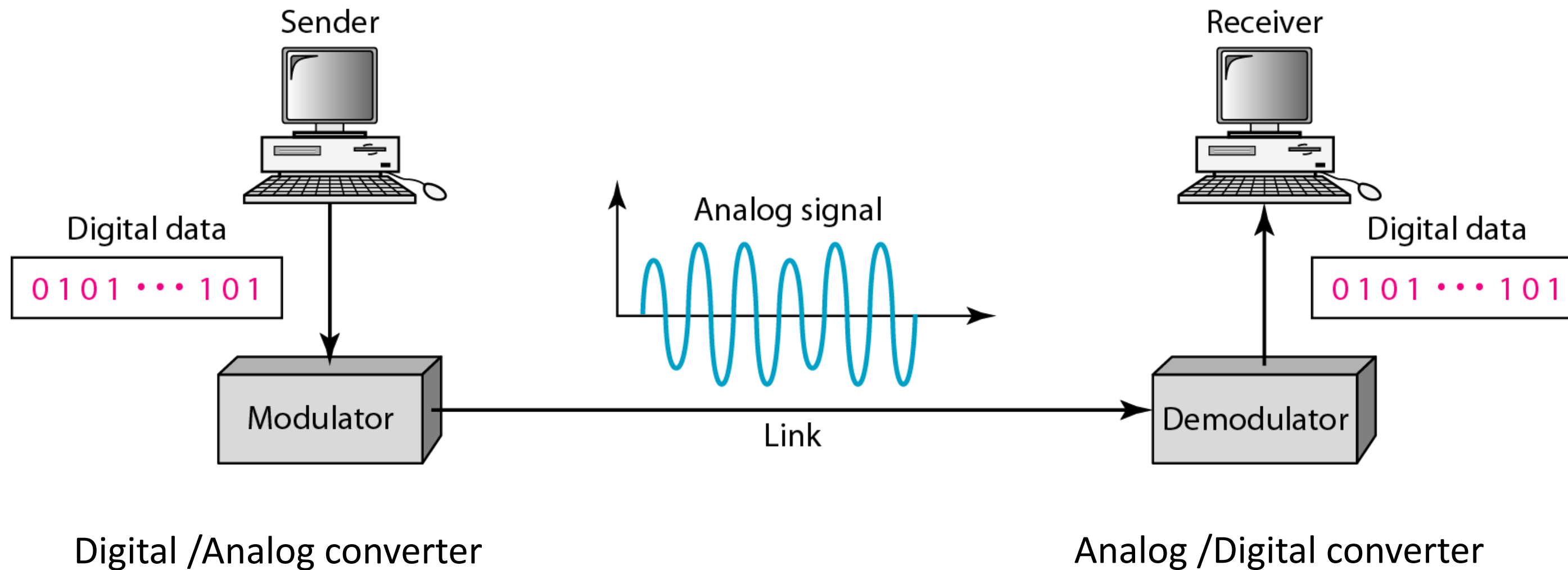



# Why we need digital modulation



- Digital modulation is required if digital data has to be transmitted over a medium that only **allows** analog transmission.
  - **Modems** in wired networks.
  - **Wireless** must use analogue sine waves.



## Types of digital-to-analog conversion

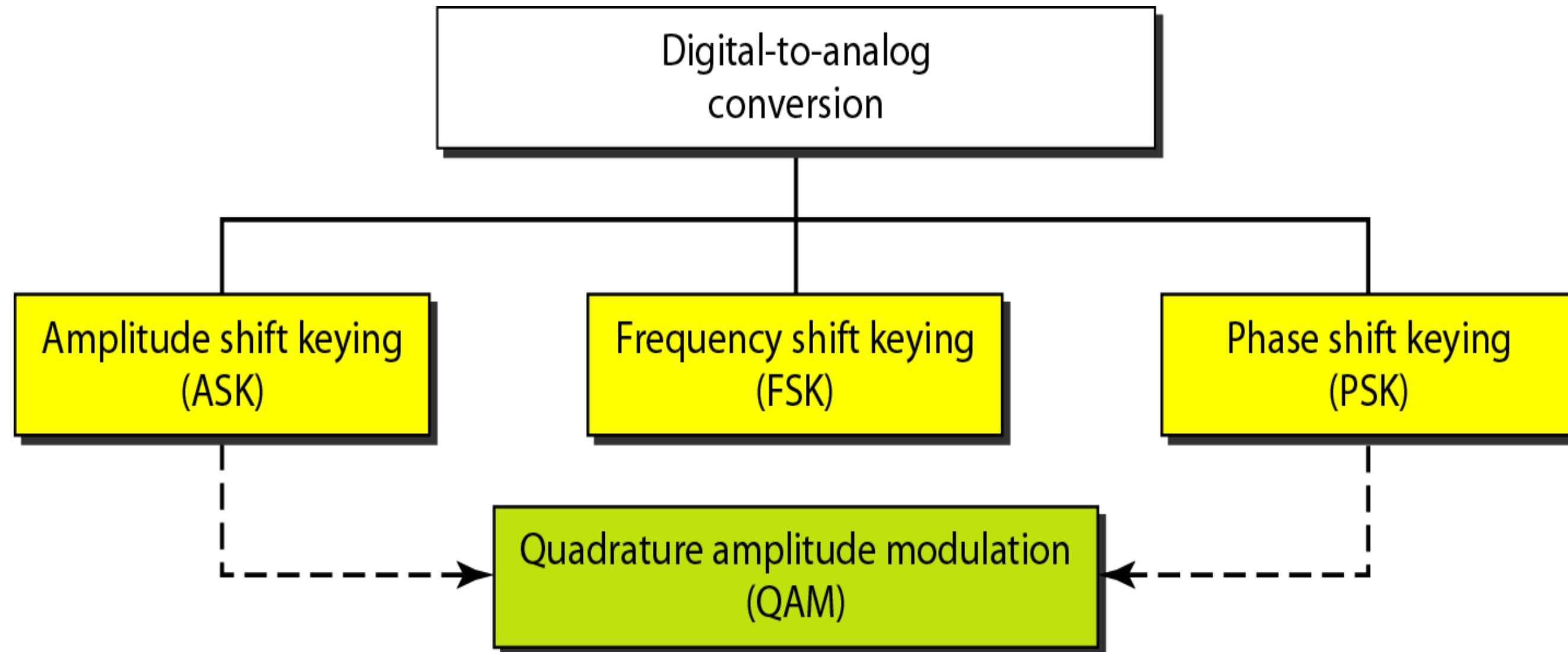



# Modulation & Demodulation

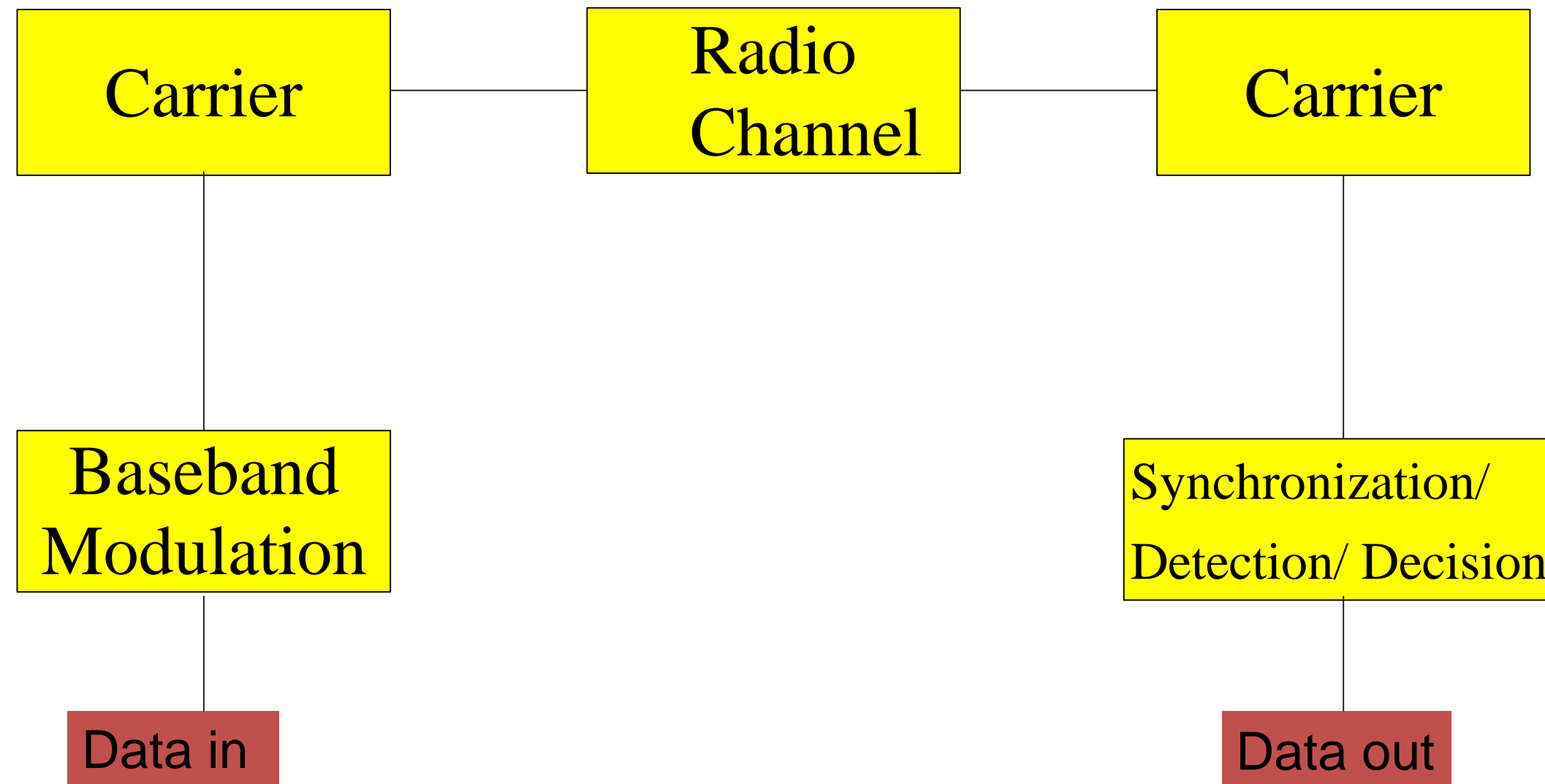





# Modulation



- Modulation :  
process (or result of the process) of translation the baseband message signal to bandpass (modulated carrier) signal at frequencies that are very high compared to the baseband frequencies.
- Demodulation is the process of extracting the baseband message back the modulated carrier.
- **An information-bearing signal** is non- deterministic, i.e. it changes in an unpredictable manner.

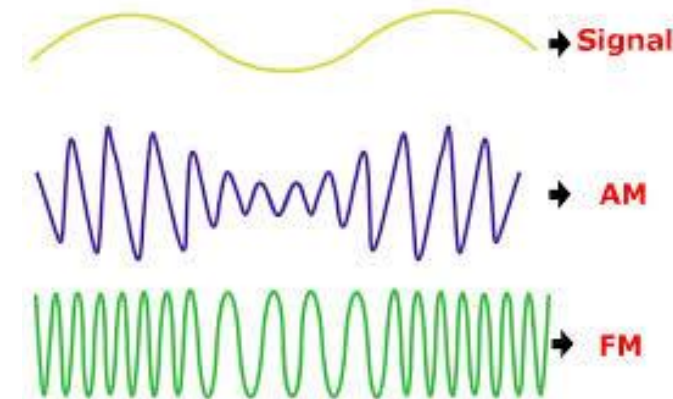





# Why Carrier?



- Effective radiation of **EM** waves requires antenna dimensions comparable with the wavelength:
  - Antenna for 3 kHz would be ~100 km long
  - Antenna for 3 GHz carrier is 10 cm long
- Sharing the access to the telecommunication channel resources



## NOTE:

- Bit rate,  $N$ , is the number of bits per second (bps).
- Baud rate is the number of signal elements per second (**bauds**).
- In the analog transmission of digital data, the signal or baud rate is **less than** or **equal** to the bit rate.

$$S = N \times 1/r \text{ bauds}$$

- Where  $r$  is the number of data bits per signal element.



## Example 1:

An analog signal carries 4 bits per signal element. If 1000 signal elements are sent per second, find the bit rate.

### Solution:

In this case,  $r = 4$ ,  $S = 1000$ , and  $N$  is unknown. We can find the value of  $N$  from

$$S = N \times \frac{1}{r} \quad \text{or} \quad N = S \times r = 1000 \times 4 = 4000 \text{ bps}$$



## Example 2:

An analog signal has a bit rate of 8000 bps and a baud rate of 1000 baud. How many data elements are carried by each signal element? How many signal elements do we need?

### Solution:

In this example,  $S = 1000$ ,  $N = 8000$ , and  $r$  and  $L$  are unknown. We find first the value of  $r$  and then the value of  $L$ .

$$S = N \times \frac{1}{r} \quad \rightarrow \quad r = \frac{N}{S} = \frac{8000}{1000} = 8 \text{ bits/ baud}$$

$$r = \log_2 L \quad \rightarrow \quad L = 2^r = 2^8 = 256$$



# Modulation Process

$$f = f(a_1, a_2, a_3, \dots, a_n, t) \quad (= \text{carrier})$$

$$a_1, a_2, a_3, \dots, a_n \quad (= \text{modulation parameters})$$

$t$  (=time)

**Modulation implies** varying one or more characteristics (modulation parameters  $a_1, a_2, \dots, a_n$ ) of a carrier  $f$  in accordance with the information-bearing (modulating) baseband signal.

**Sinusoidal waves**, pulse train, square wave, etc. can be used as carriers



# Amplitude Shift Keying(ASK)

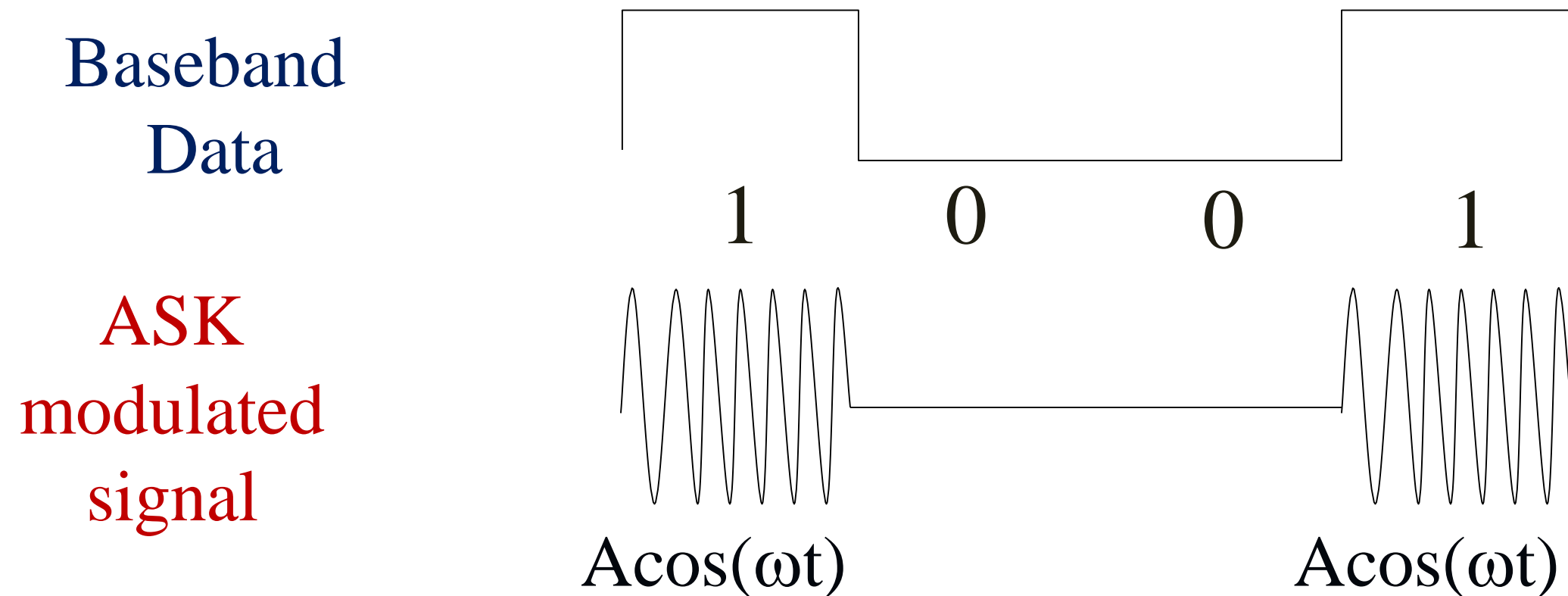

- Pulse shaping can be employed to remove spectral spreading
- ASK demonstrates poor performance, as it is heavily affected by noise, fading, and interference





# Amplitude Shift Keying (ASK)

- In **ASK** the amplitude of the carrier signal is varied to represent binary 1 or 0.
  - Carrier signal is a high frequency signal that acts as a basis for the information signal.
  - Both frequency and phase remain constant while the amplitude changes.
  - The peak amplitude of the signal during each bit duration is constant, and its value depends on the bit (0 or 1).

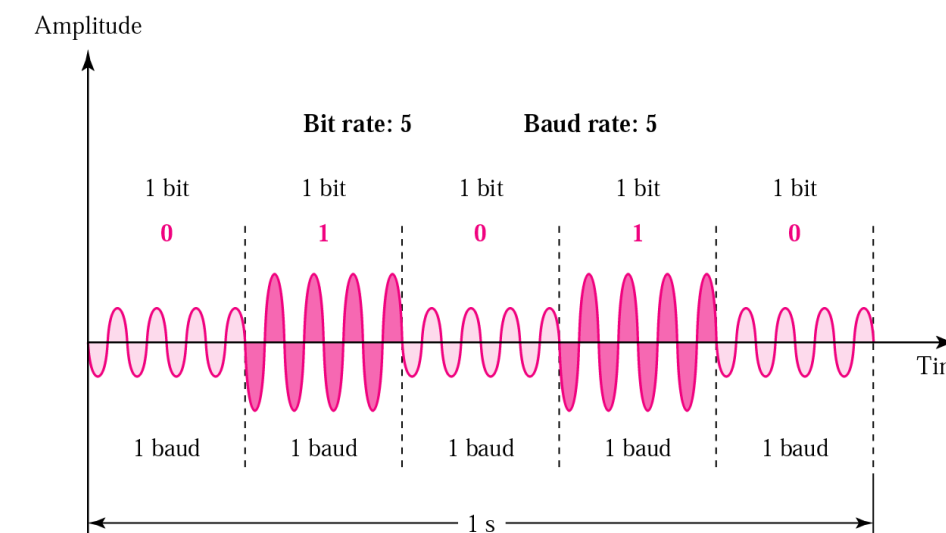
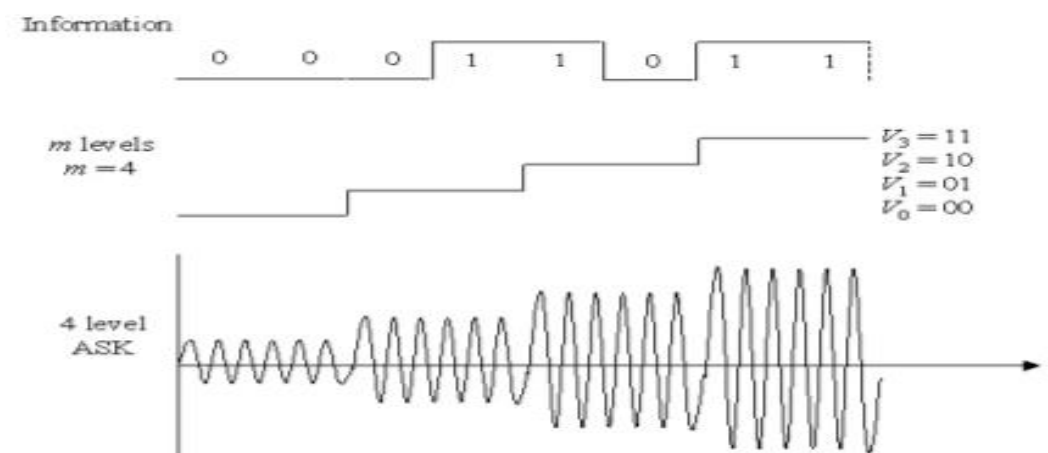



# Binary ASK (BASK) or On Off Keying (OOK)



- Although we can have several levels of signal elements, each with a different amplitude, ASK is normally implemented using **only two levels**. This is referred to as binary amplitude shift keying.
- In ON OFF Keying: bit **0** is represented by the absence of a carrier and bit **1** is represented by the presence of a carrier .

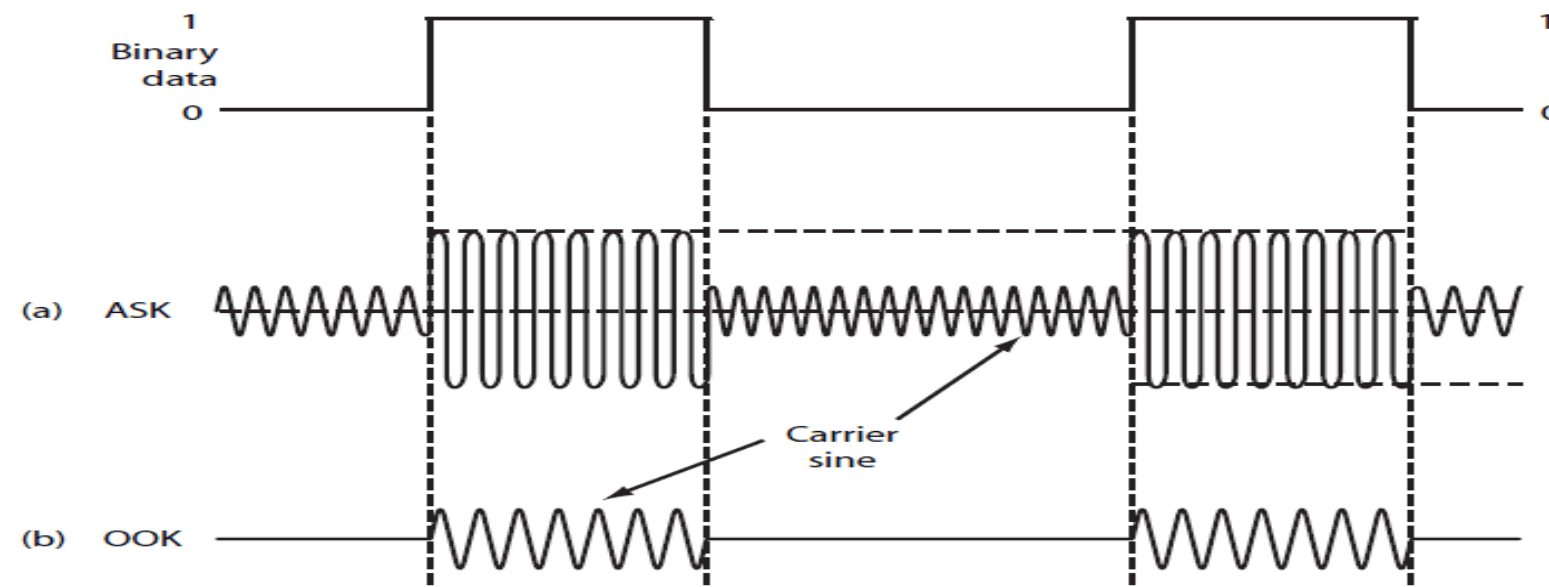



# Pros and Cons



## - Pros:

ASK transmitter and receiver are simple to design.

ASK needs less bandwidth than FSK.

## - Cons:

ASK transmission can be easily corrupted by noise.

## - Application:

Early telephone modem (AFSK).

ASK is used to transmit digital data over optical fiber.



# Frequency Shift Keying (FSK)

Baseband  
Data

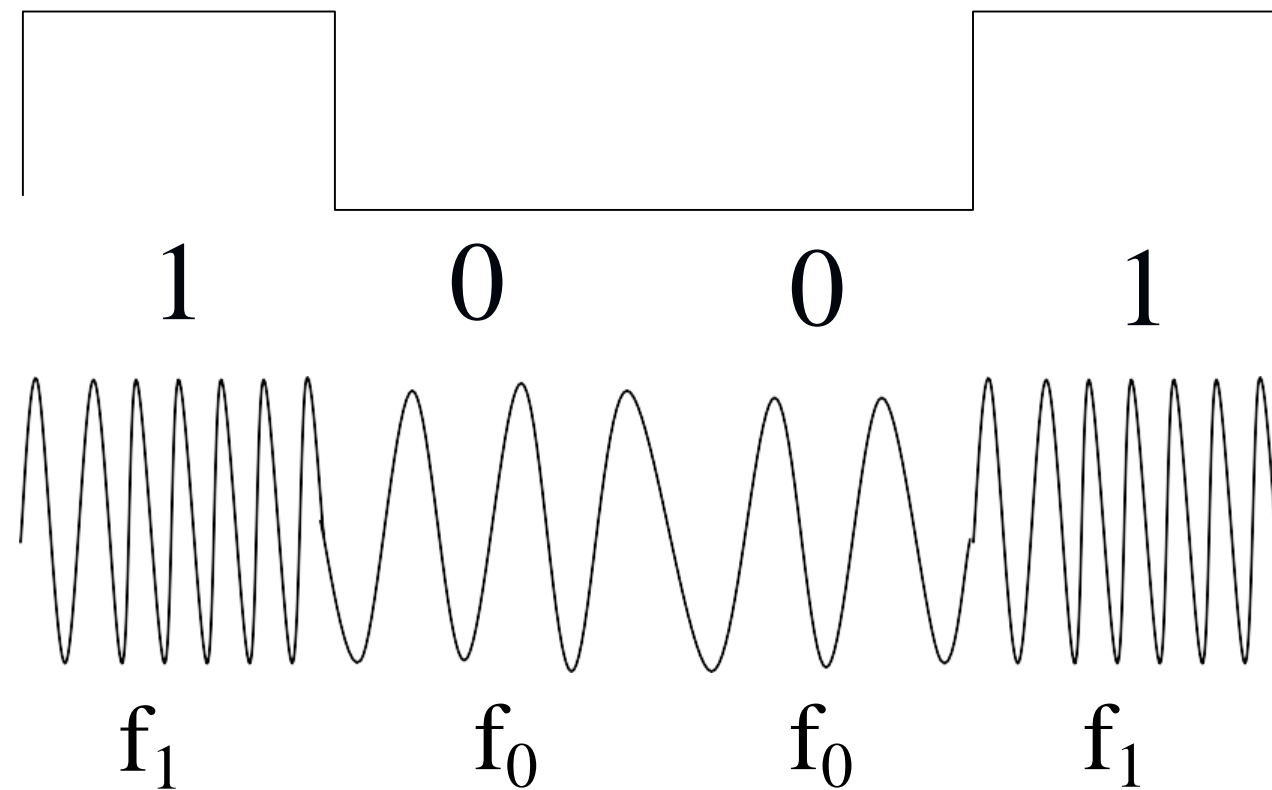

**BFSK**  
modulated  
signal

where  $f_0 = A \cos(\omega_c - \Delta\omega)t$  and  $f_1 = A \cos(\omega_c + \Delta\omega)t$

- **Example:** The ITU-T V.21 modem standard uses FSK
- FSK can be expanded to a M-ary scheme, employing multiple frequencies as different states



# FSK (Frequency Shift Keying)



- The frequency of the carrier signal is varied to represent binary **1** or **0**.
- Both peak amplitude and phase remain constant while the frequency changes.
- The frequency of the signal during each bit duration is constant, and its value depends on the bit (0 or 1).

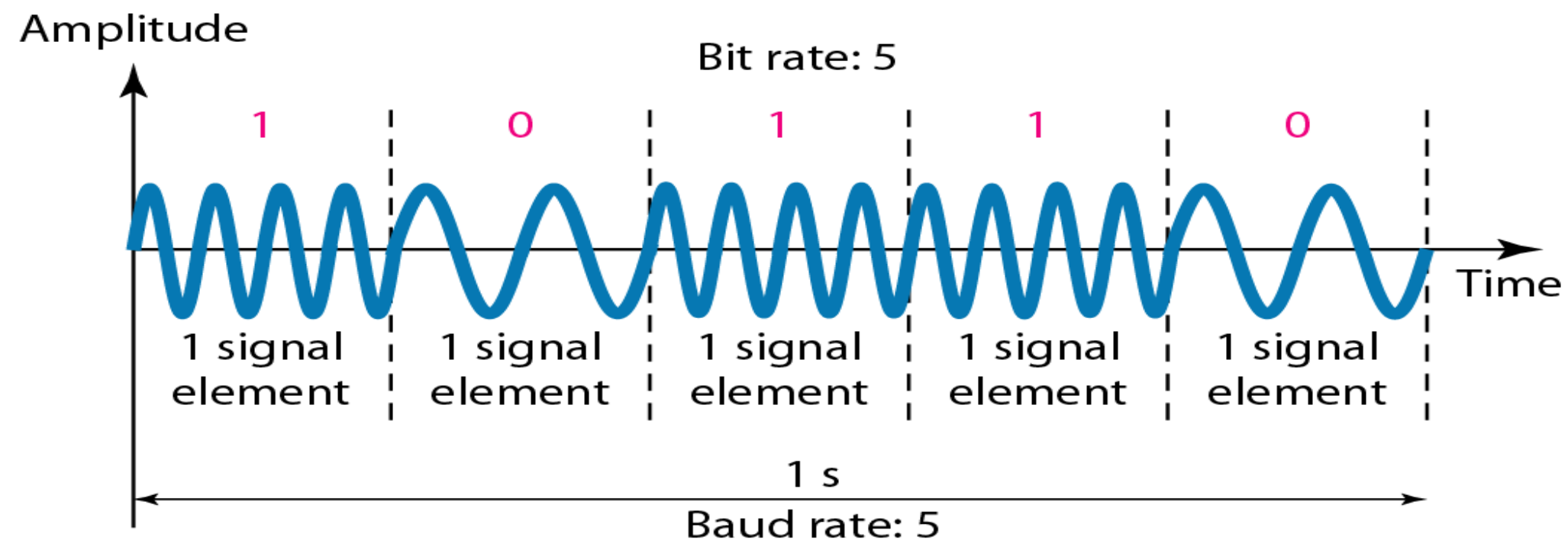





# FSK Modulator



- One way to think about binary FSK (or BFSK) is to consider two carrier frequencies

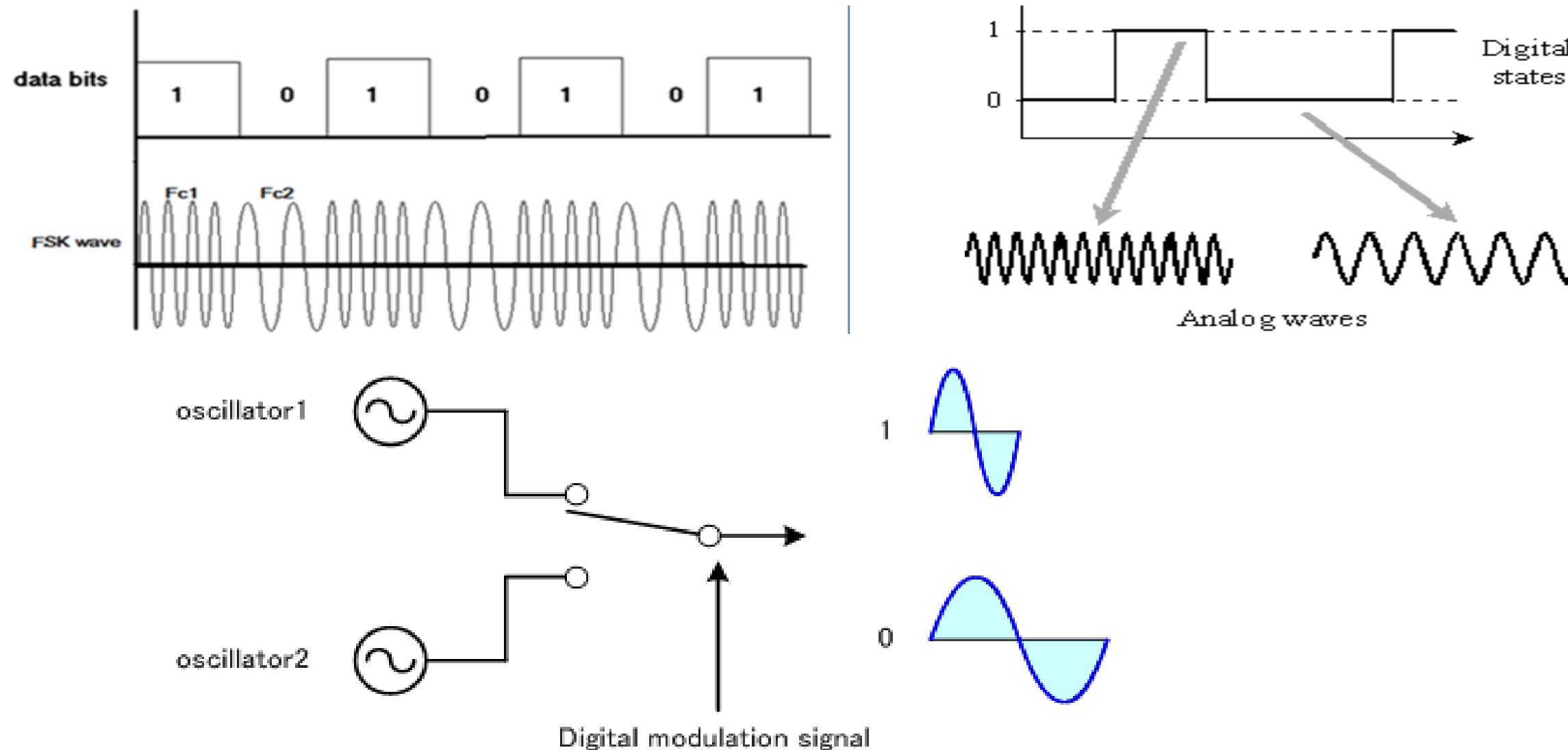

Switch between two oscillators accordingly





# ASK and FSK

Amplitude Shift Keying (ASK)	Frequency Shift Keying (FSK)
<ul style="list-style-type: none"><li>• Very simple.</li></ul>	<ul style="list-style-type: none"><li>• Needs larger bandwidth.</li></ul>
<ul style="list-style-type: none"><li>• Low bandwidth requirements.</li></ul>	<ul style="list-style-type: none"><li>• More error resilience than AM.</li></ul>
<ul style="list-style-type: none"><li>• Very susceptible to interference</li></ul>	

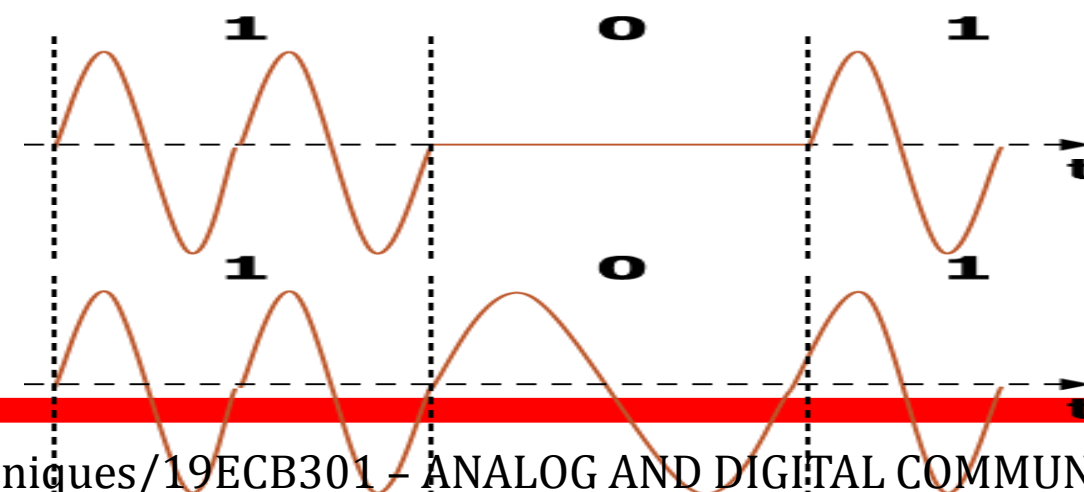



# Phase Shift Keying (PSK)

Baseband  
Data

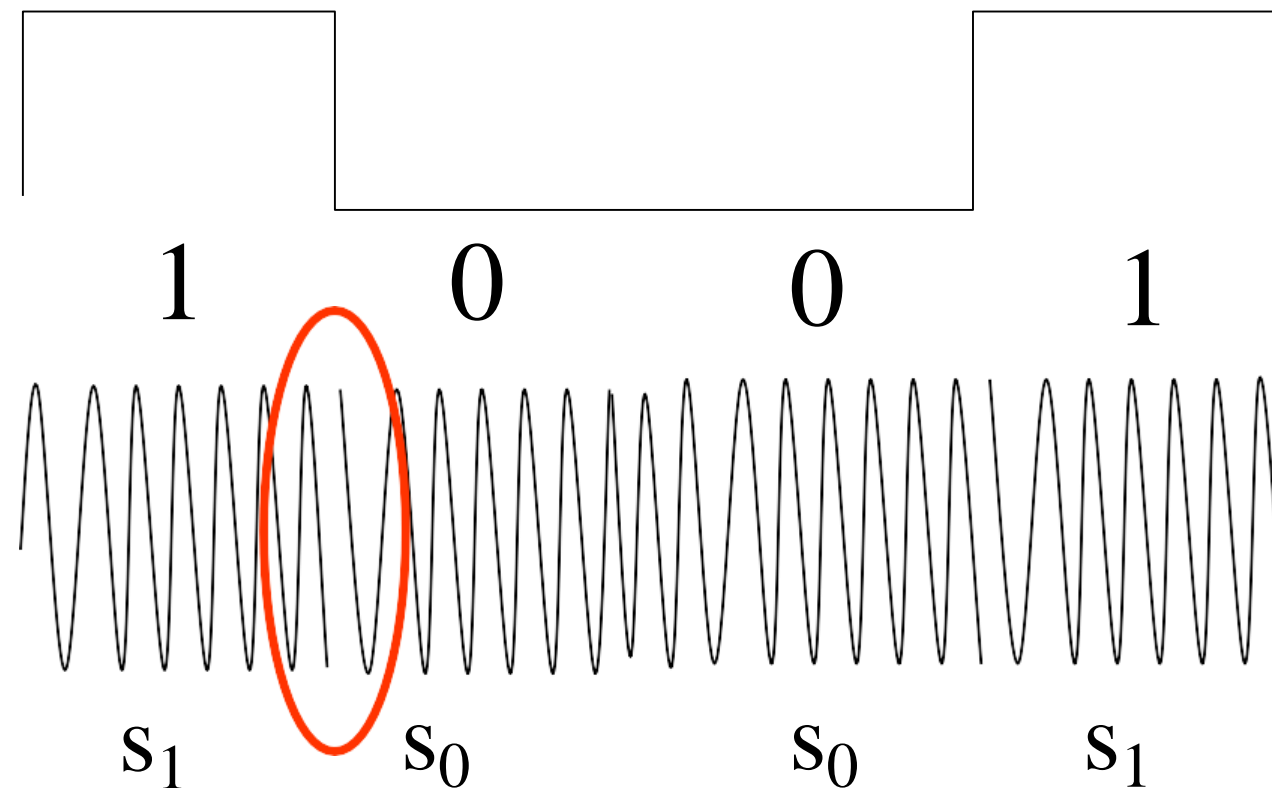

**BPSK**  
modulated  
signal

where  $s_0 = -A\cos(\omega_c t)$  and  $s_1 = A\cos(\omega_c t)$

- Major drawback – rapid amplitude change between symbols due to phase discontinuity, which requires **infinite bandwidth**. **Binary Phase Shift Keying** (BPSK) demonstrates better performance than **ASK** and **BFSK**
- BPSK can be expanded to a M-ary scheme, employing multiple phases and amplitudes as different states



# Phase Shift Keying

In phase shift keying, the phase of the carrier is varied to represent two or more different signal elements (Both peak amplitude and frequency remain constant).

In binary PSK, we have only two signal elements: one with a phase of  $0^\circ$ , and the other with a phase of  $180^\circ$ .

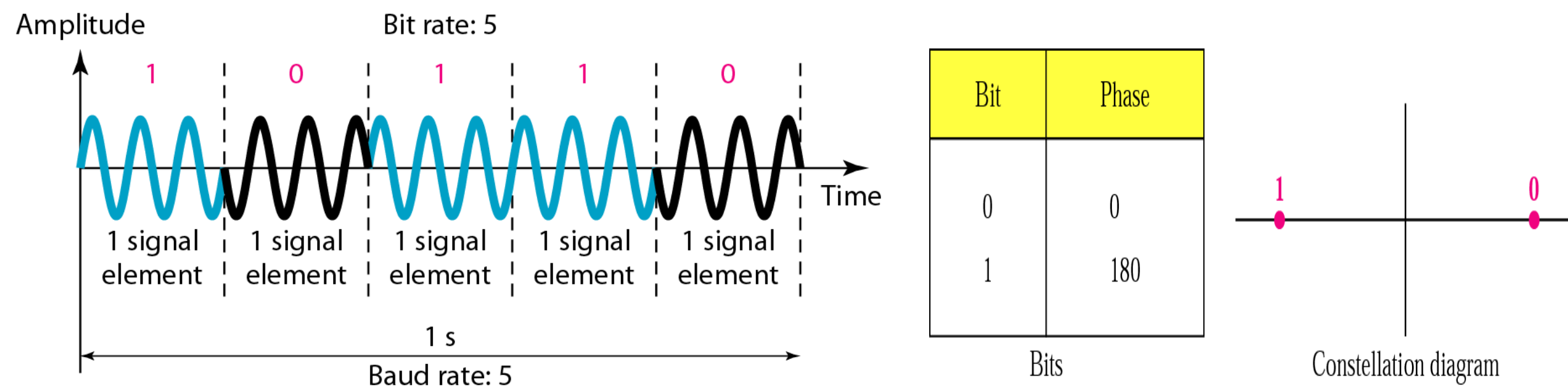



# Bandwidth of Binary PSK

PSK is less susceptible to noise than ASK.

PSK is superior to FSK because we do not need two carrier signals.

The implementation of BPSK :

the signal element with phase  $180^\circ$  can be seen as the complement of the signal element with phase  $0^\circ$ .

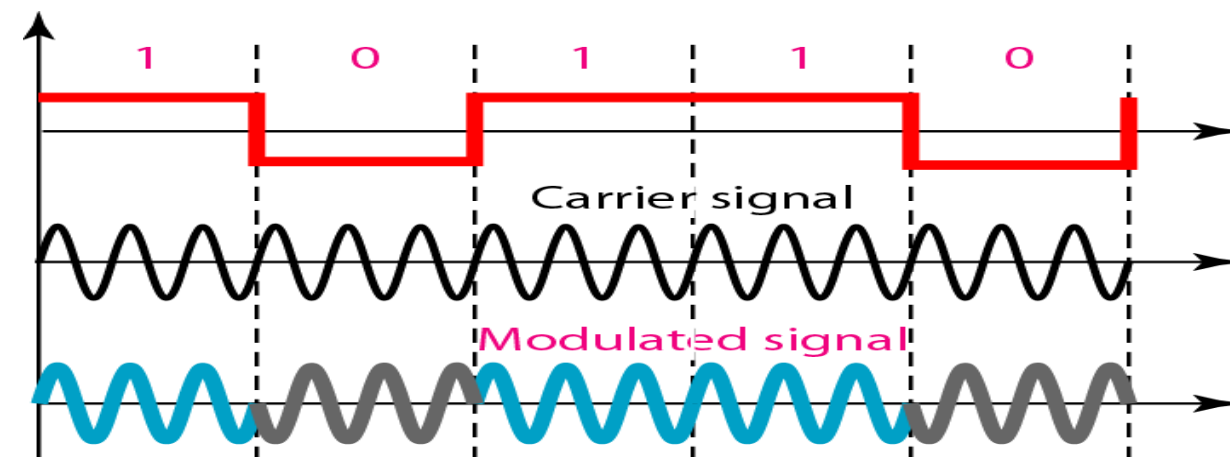



# Digital Modulation Summary

Amplitude Shift Keying (ASK)	Frequency Shift Keying (FSK)	Phase Shift Keying (PSK)
<ul style="list-style-type: none"><li>• Very simple.</li></ul>	<ul style="list-style-type: none"><li>• Needs larger bandwidth.</li></ul>	<ul style="list-style-type: none"><li>• More complex.</li></ul>
<ul style="list-style-type: none"><li>• Low bandwidth requirements</li></ul>	<ul style="list-style-type: none"><li>• More error resilience than AM.</li></ul>	<ul style="list-style-type: none"><li>• Robust against interference.</li></ul>
<ul style="list-style-type: none"><li>• Very susceptible to interference</li></ul>		



# Digital Modulation Summary

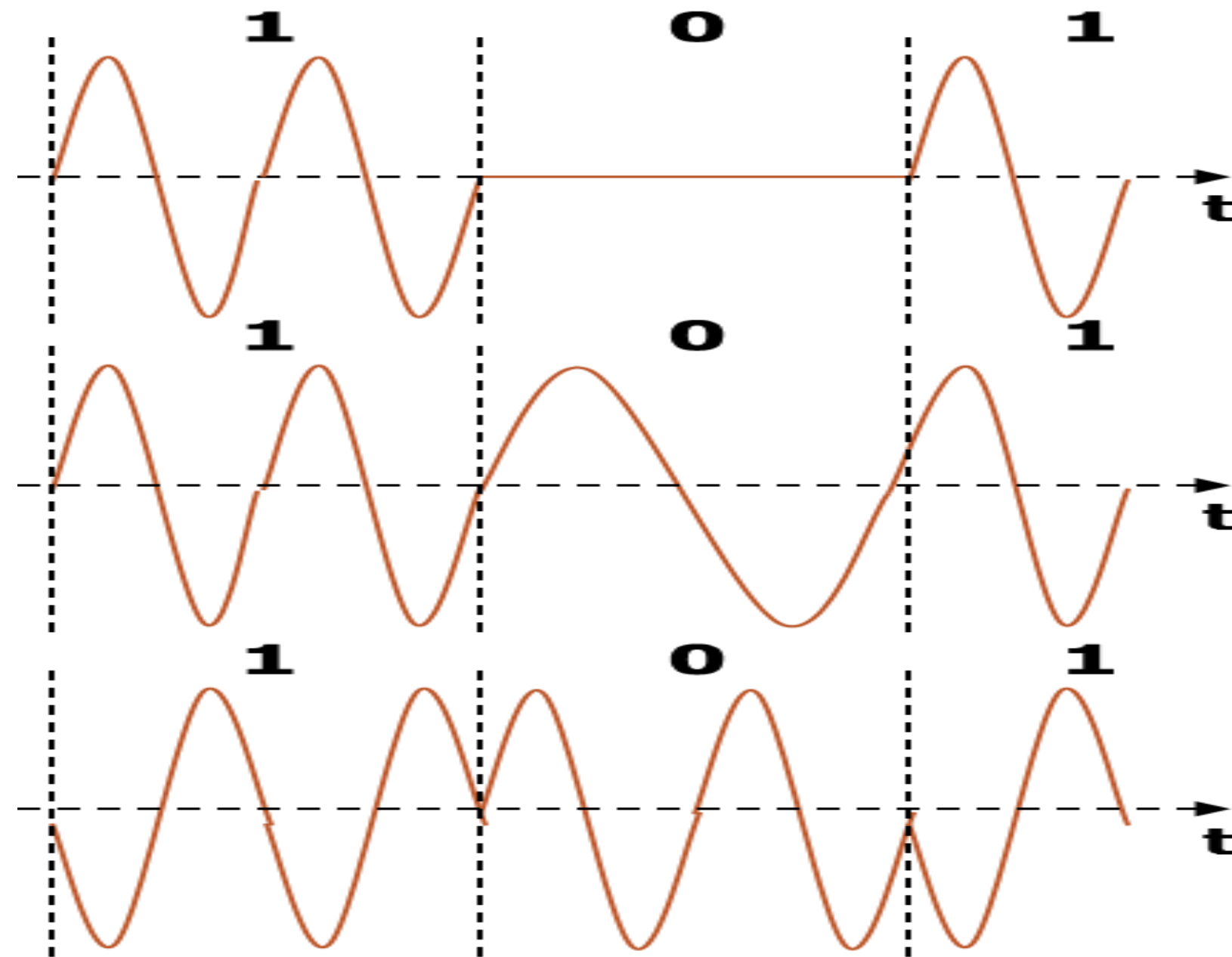





**THANK YOU**