

GATE SOLVED PAPER - EC

DIGITAL CIRCUITS

2013

ONE MARK

- q. 1 A bulb in a staircase has two switches, one switch being at the ground floor and the other one at the first floor. The bulb can be turned ON and also can be turned OFF by any one of the switches irrespective of the state of the other switch. The logic of switching of the bulb resembles
(A) an AND gate (B) an OR gate
(C) an XOR gate (D) a NAND gate
- q. 2 For 8085 microprocessor, the following program is executed.
MVI A, 05H;
MVI B, 05H;
PTR: ADD B;
DCR B;
JNZ PTR;
ADI 03H;
HLT;
At the end of program, accumulator contains
(A) 17H (B) 20H
(C) 23H (D) 05H

2013

TWO MARKS

- q. 3 There are four chips each of 1024 bytes connected to a 16 bit address bus as shown in the figure below, RAMs 1, 2, 3 and 4 respectively are mapped to addresses

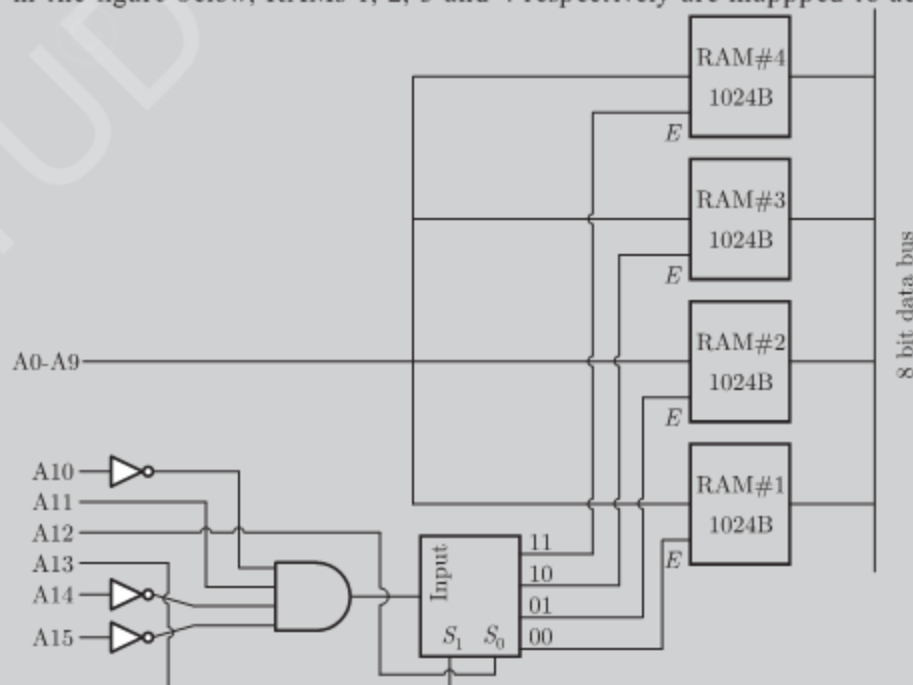

- (A) 0C00H-0FFFH, 1C00H-1FFFH, 2C00H-2FFFH, 3C00H-3FFFH
- (B) 1800H-1FFFH, 2800H-2FFFH, 3800H-3FFFH, 4800H-4FFFH
- (C) 0500H-08FFFH, 1500H-18FFFH, 3500H-38FFFH, 5500H-58FFFH
- (D) 0800H-0BFFFH, 1800H-1BFFFH, 2800H-2BFFFH, 3800H-3BFFFH

2012

ONE MARK

q. 4

Consider the given circuit

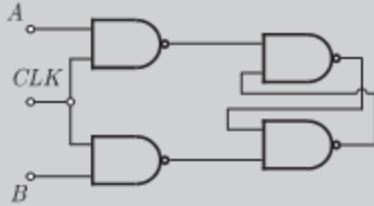

In this circuit, the race around

- (A) does not occur
 - (B) occur when $CLK = 0$
 - (C) occur when $CLK = 1$ and $A = B = 1$
 - (D) occur when $CLK = 1$ and $A = B = 0$
- q. 5 The output Y of a 2-bit comparator is logic 1 whenever the 2-bit input A is greater than the 2-bit input B . The number of combinations for which the output is logic 1, is
- (A) 4
 - (B) 6
 - (C) 8
 - (D) 10

q. 6

In the circuit shown

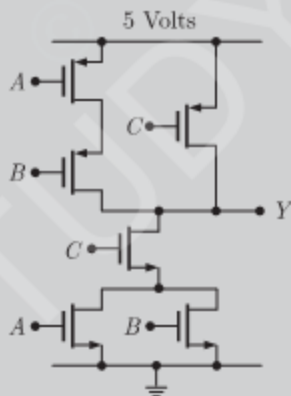

- (A) $Y = \bar{A} \bar{B} + \bar{C}$
 - (B) $Y = (A + B) C$
 - (C) $Y = (\bar{A} + \bar{B}) \bar{C}$
 - (D) $Y = AB + C$
- q. 7 In the sum of products function $f(X, Y, Z) = \sum(2, 3, 4, 5)$, the prime implicants are
- (A) $\bar{X}Y, X\bar{Y}$
 - (B) $\bar{X}Y, X\bar{Y}\bar{Z}, X\bar{Y}Z$
 - (C) $\bar{X}Y\bar{Z}, \bar{X}YZ, X\bar{Y}$
 - (D) $\bar{X}Y\bar{Z}, \bar{X}YZ, X\bar{Y}\bar{Z}, X\bar{Y}Z$

q. 8

The state transition diagram for the logic circuit shown is

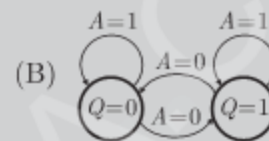
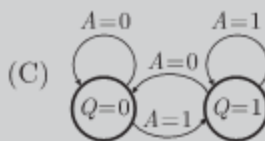
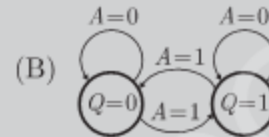
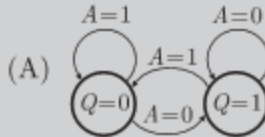
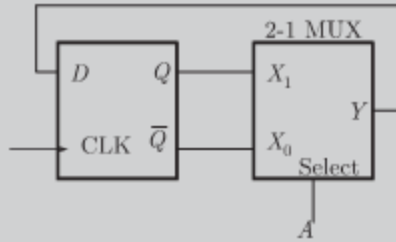

q. 9

The output Y in the circuit below is always '1' when

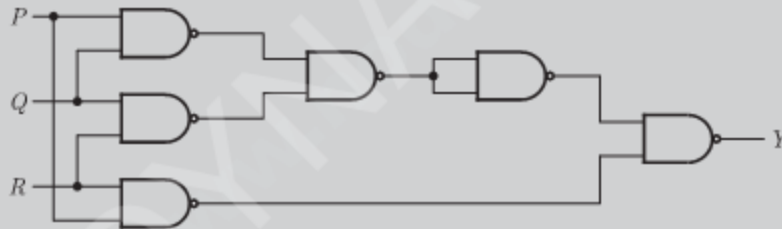

- (A) two or more of the inputs P, Q, R are '0'
- (B) two or more of the inputs P, Q, R are '1'
- (C) any odd number of the inputs P, Q, R is '0'
- (D) any odd number of the inputs P, Q, R is '1'

q. 10

When the output Y in the circuit below is "1", it implies that data has

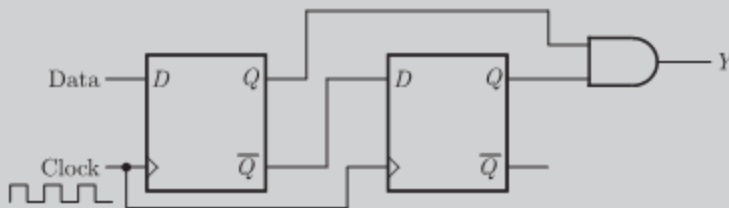

- (A) changed from "0" to "1"
- (B) changed from "1" to "0"
- (C) changed in either direction
- (D) not changed

Q. 11

The logic function implemented by the circuit below is (ground implies a logic "0")

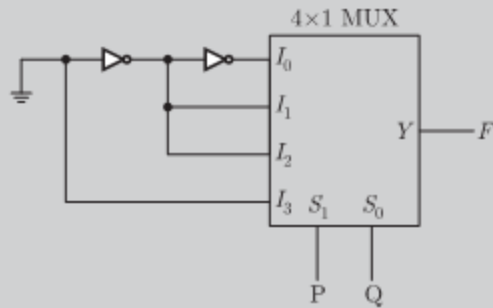

(A) $F = \text{AND}(P, Q)$

(B) $F = \text{OR}(P, Q)$

(C) $F = \text{XNOR}(P, Q)$

(D) $F = \text{XOR}(P, Q)$

2011

TWO MARKS

Q. 12

The output of a 3-stage Johnson (twisted ring) counter is fed to a digital-to-analog (D/A) converter as shown in the figure below. Assume all states of the counter to be unset initially. The waveform which represents the D/A converter output V_o is

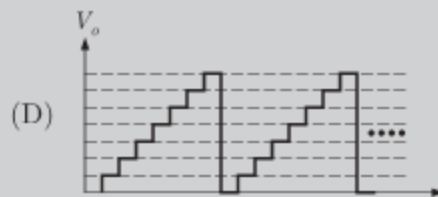
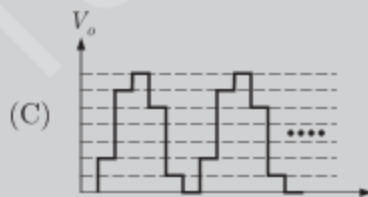
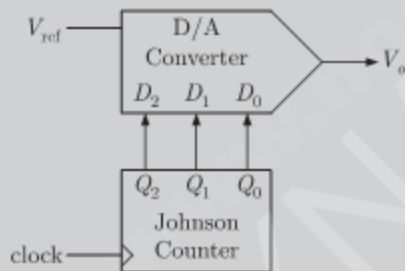

Q. 13

Two D flip-flops are connected as a synchronous counter that goes through the following $Q_B Q_A$ sequence $00 \rightarrow 11 \rightarrow 01 \rightarrow 10 \rightarrow 00 \rightarrow \dots$

The connections to the inputs D_A and D_B are

(A) $D_A = Q_B, D_B = Q_A$

(B) $D_A = \bar{Q}_A, D_B = \bar{Q}_B$

(C) $D_A = (Q_A \bar{Q}_B + \bar{Q}_A Q_B), D_B = Q_A$

(D) $D_A = (Q_A Q_B + \bar{Q}_A \bar{Q}_B), D_B = \bar{Q}_B$

Q. 14

An 8085 assembly language program is given below. Assume that the carry flag is initially unset. The content of the accumulator after the execution of the program is

```

MVI  A, 07H
RLC
MOV  B, A
RLC
RLC
ADD  B
RRC
    
```

- (A) 8CH (B) 64H
(C) 23H (D) 15H

2010

ONE MARK

Q. 15

Match the logic gates in Column A with their equivalents in Column B

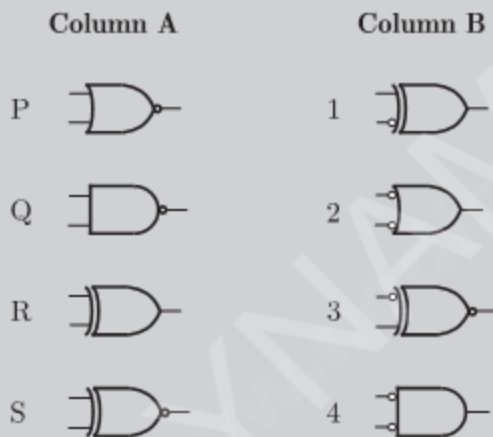

- (A) P-2, Q-4, R-1, S-3 (B) P-4, Q-2, R-1, S-3
(C) P-2, Q-4, R-3, S-1 (D) P-4, Q-2, R-3, S-1

Q. 16

In the circuit shown, the device connected Y5 can have address in the range

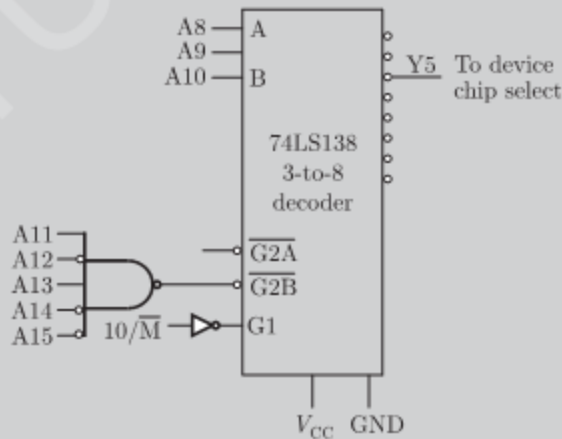

- (A) 2000 - 20FF (B) 2D00 - 2DFF
(C) 2E00 - 2EFF (D) FD00 - FDFE

- q. 17 For the output F to be 1 in the logic circuit shown, the input combination should be

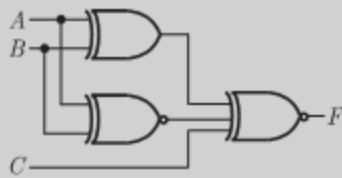

- (A) $A = 1, B = 1, C = 0$ (B) $A = 1, B = 0, C = 0$
 (C) $A = 0, B = 1, C = 0$ (D) $A = 0, B = 0, C = 1$

2010

TWO MARKS

- q. 18 Assuming that the flip-flop are in reset condition initially, the count sequence observed at Q_A , in the circuit shown is

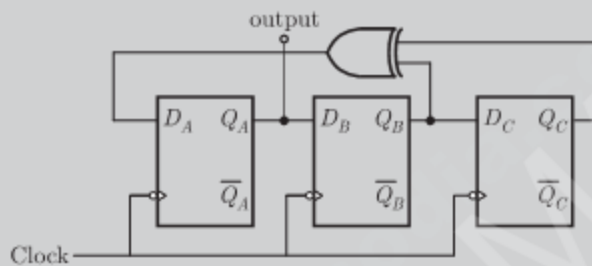

- (A) 0010111... (B) 0001011...
 (C) 0101111... (D) 0110100....

- q. 19 The Boolean function realized by the logic circuit shown is

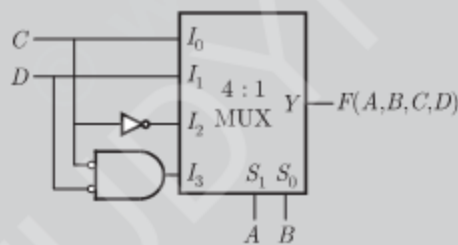

- (A) $F = \sum m(0, 1, 3, 5, 9, 10, 14)$ (B) $F = \sum m(2, 3, 5, 7, 8, 12, 13)$
 (C) $F = \sum m(1, 2, 4, 5, 11, 14, 15)$ (D) $F = \sum m(2, 3, 5, 7, 8, 9, 12)$

- q. 20 For the 8085 assembly language program given below, the content of the accumulator after the execution of the program is

3000	MVI	A,	45H
3002	MOV	B,	A
3003	STC		
3004	CMC		
3005	RAR		
3006	XRA	B	

- (A) 00H (B) 45H
 (C) 67H (D) E7H

- q. 21 The full form of the abbreviations TTL and CMOS in reference to logic families are
- (A) Triple Transistor Logic and Chip Metal Oxide Semiconductor
 (B) Tristate Transistor Logic and Chip Metal Oxide Semiconductor
 (C) Transistor Transistor Logic and Complementary Metal Oxide Semiconductor
 (D) Tristate Transistor Logic and Complementary Metal Oxide Silicon
- q. 22 In a microprocessor, the service routine for a certain interrupt starts from a fixed location of memory which cannot be externally set, but the interrupt can be delayed or rejected. Such an interrupt is
- (A) non-maskable and non-vectorized
 (B) maskable and non-vectorized
 (C) non-maskable and vectorized
 (D) maskable and vectorized

- q. 23 If $X = 1$ in logic equation $[X + Z\{\bar{Y} + (\bar{Z} + X\bar{Y})\}]\{\bar{X} + \bar{X}(X + Y)\} = 1$, then
- (A) $Y = Z$ (B) $Y = \bar{Z}$
 (C) $Z = 1$ (D) $Z = 0$
- q. 24 What are the minimum number of 2-to-1 multiplexers required to generate a 2-input AND gate and a 2-input Ex-OR gate
- (A) 1 and 2 (B) 1 and 3
 (C) 1 and 1 (D) 2 and 2
- q. 25 What are the counting states (Q_1, Q_2) for the counter shown in the figure below

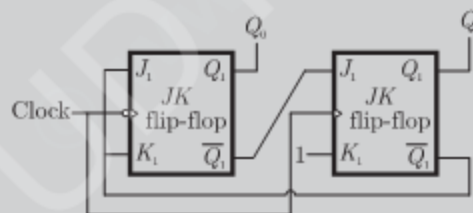

- (A) 11, 10, 00, 11, 10, ... (B) 01, 10, 11, 00, 01, ...
 (C) 00, 11, 01, 10, 00, ... (D) 01, 10, 00, 01, 10, ...

Statement for Linked Answer Question 26 & 27 :

Two products are sold from a vending machine, which has two push buttons P_1 and P_2 .

When a button is pressed, the price of the corresponding product is displayed in a 7-segment display. If no buttons are pressed, '0' is displayed signifying 'Rs 0'.

If only P_1 is pressed, '2' is displayed, signifying 'Rs. 2'

If only P_2 is pressed '5' is displayed, signifying 'Rs. 5'

If both P_1 and P_2 are pressed, 'E' is displayed, signifying 'Error'

The names of the segments in the 7 - segment display, and the glow of the display for '0', '2', '5' and 'E' are shown below.



Consider

- (1) push buttons pressed/ not pressed in equivalent to logic 1/0 respectively.
- (2) a segment glowing/ not glowing in the display is equivalent to logic 1/0 respectively.

Q. 26 If segments a to g are considered as functions of P_1 and P_2 , then which of the following is correct

- (A) $g = \bar{P}_1 + P_2, d = c + e$ (B) $g = P_1 + P_2, d = c + e$
 (C) $g = \bar{P}_1 + P_2, e = b + c$ (D) $g = P_1 + P_2, e = b + c$

Q. 27 What are the minimum numbers of NOT gates and 2 - input OR gates required to design the logic of the driver for this 7 - Segment display

- (A) 3 NOT and 4 OR (B) 2 NOT and 4 OR
 (C) 1 NOT and 3 OR (D) 2 NOT and 3 OR

Q. 28 Refer to the NAND and NOR latches shown in the figure. The inputs (P_1, P_2) for both latches are first made (0, 1) and then, after a few seconds, made (1, 1). The corresponding stable outputs (Q_1, Q_2) are

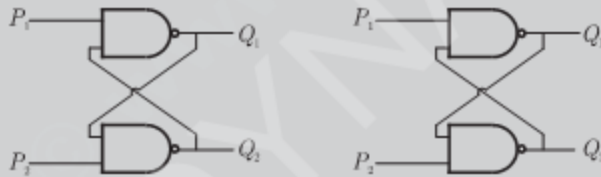

- (A) NAND: first (0, 1) then (0, 1) NOR: first (1, 0) then (0, 0)
 (B) NAND : first (1, 0) then (1, 0) NOR : first (1, 0) then (1, 0)
 (C) NAND : first (1, 0) then (1, 0) NOR : first (1, 0) then (0, 0)
 (D) NAND : first (1, 0) then (1, 1) NOR : first (0, 1) then (0, 1)

2008

TWO MARKS

Q. 29 The logic function implemented by the following circuit at the terminal OUT is

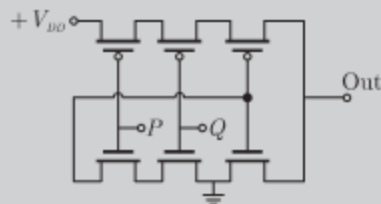

- (A) P NOR Q (B) P NAND Q
 (C) P OR Q (D) P AND Q

- q. 30 The two numbers represented in signed 2's complement form are $P = 11101101$ and $Q = 11100110$. If Q is subtracted from P , the value obtained in signed 2's complement is
- (A) 1000001111 (B) 00000111
(C) 11111001 (D) 11111001

- q. 31 Which of the following Boolean Expressions correctly represents the relation between P, Q, R and M_1

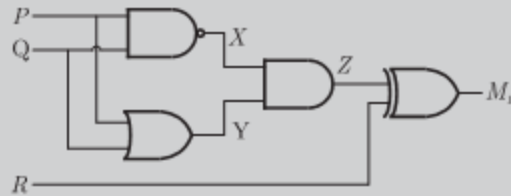

- (A) $M_1 = (P \text{ OR } Q) \text{ XOR } R$
(B) $M_1 = (P \text{ AND } Q) \text{ XOR } R$
(C) $M_1 = (P \text{ NOR } Q) \text{ XOR } R$
(D) $M_1 = (P \text{ XOR } Q) \text{ XOR } R$
- q. 32 For the circuit shown in the figure, D has a transition from 0 to 1 after CLK changes from 1 to 0. Assume gate delays to be negligible. Which of the following statements is true

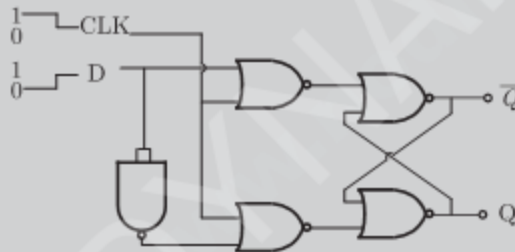

- (A) Q goes to 1 at the CLK transition and stays at 1
(B) Q goes to 0 at the CLK transition and stays 0
(C) Q goes to 1 at the CLK transition and goes to 0 when D goes to 1
(D) Q goes to 0 at the CLK transition and goes to 1 when D goes to 1
- q. 33 For each of the positive edge-triggered $J-K$ flip flop used in the following figure, the propagation delay is Δt .

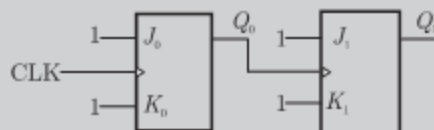

Which of the following wave forms correctly represents the output at Q_1 ?

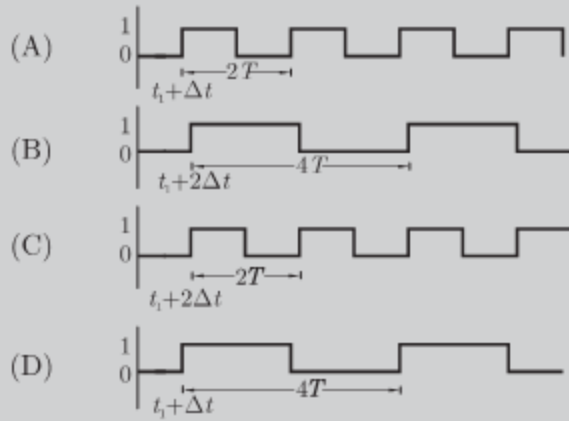

Statement For Linked Answer Question 34 & 35 :

In the following circuit, the comparators output is logic "1" if $V_1 > V_2$ and is logic "0" otherwise. The D/A conversion is done as per the relation $V_{DAC} = \sum_{n=0}^3 2^{n-1} b_n$ Volts, where b_3 (MSB), b_1, b_2 and b_0 (LSB) are the counter outputs. The counter starts from the clear state.

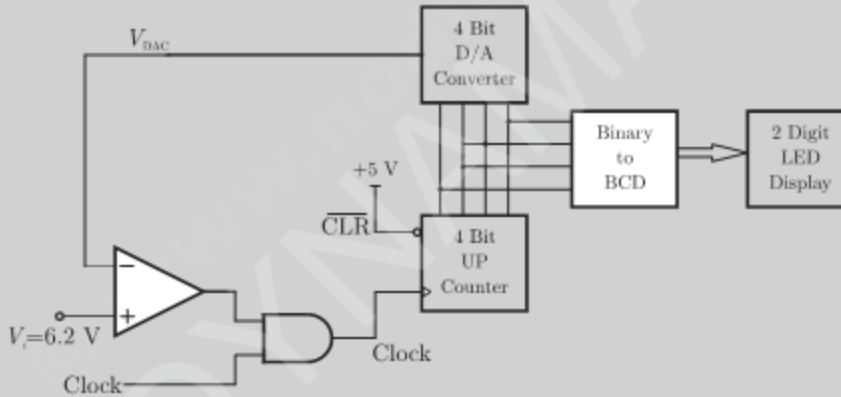

- q. 34 The stable reading of the LED displays is
 (A) 06 (B) 07
 (C) 12 (D) 13
- q. 35 The magnitude of the error between V_{DAC} and V_{in} at steady state in volts is
 (A) 0.2 (B) 0.3
 (C) 0.5 (D) 1.0
- q. 36 For the circuit shown in the following, $I_0 - I_3$ are inputs to the 4:1 multiplexers, R (MSB) and S are control bits. The output Z can be represented by

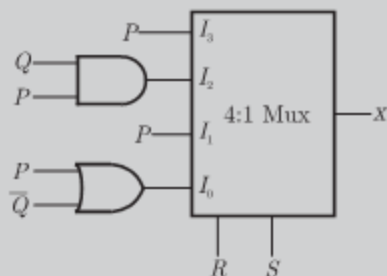

- (A) $PQ + P\overline{Q}S + \overline{Q}RS$
 (B) $P\overline{Q} + P\overline{Q}R + \overline{P}QS$
 (C) $P\overline{Q}R + \overline{P}QR + PARS + \overline{Q}RS$
 (D) $P\overline{Q}R + P\overline{Q}RS + P\overline{Q}RS + \overline{Q}RS$

q. 37

An 8085 executes the following instructions

2710 LXI H, 30A0 H

2713 DAD H

2414 PCHL

All address and constants are in Hex. Let PC be the contents of the program counter and HL be the contents of the HL register pair just after executing PCHL. Which of the following statements is correct ?

- (A) PC = 2715H
 HL = 30A0H
 (B) PC = 30A0H
 HL = 2715H
 (C) PC = 6140H
 HL = 6140H
 (D) PC = 6140H
 HL = 2715H

2007

ONE MARK

q. 38

$X = 01110$ and $Y = 11001$ are two 5-bit binary numbers represented in two's complement format. The sum of X and Y represented in two's complement format using 6 bits is

- (A) 100111
 (B) 0010000
 (C) 000111
 (D) 101001

q. 39

The Boolean function $Y = AB + CD$ is to be realized using only 2 - input NAND gates. The minimum number of gates required is

- (A) 2
 (B) 3
 (C) 4
 (D) 5

2007

TWO MARKS

q. 40

In the following circuit, X is given by

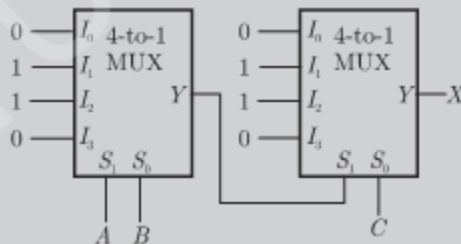

- (A) $X = A\overline{B}\overline{C} + \overline{A}B\overline{C} + \overline{A}\overline{B}C + ABC$
 (B) $X = \overline{A}BC + A\overline{B}C + ABC + \overline{A}\overline{B}C$
 (C) $X = AB + BC + AC$
 (D) $X = \overline{A}B + \overline{B}C + \overline{A}C$

q. 41

The Boolean expression $Y = \overline{A}BCD + \overline{A}BC\overline{D} + \overline{A}B\overline{C}D + \overline{A}B\overline{C}\overline{D}$ can be minimized to

- (A) $Y = \overline{A}BCD + \overline{A}B\overline{C} + A\overline{C}D$
 (B) $Y = \overline{A}BCD + B\overline{C}D + \overline{A}B\overline{C}D$
 (C) $Y = \overline{A}BCD + \overline{B}CD + \overline{A}B\overline{C}D$
 (D) $Y = \overline{A}BCD + \overline{B}CD + \overline{A}B\overline{C}D$

Q. 42

The circuit diagram of a standard TTL NOT gate is shown in the figure. $V_i = 25$ V, the modes of operation of the transistors will be

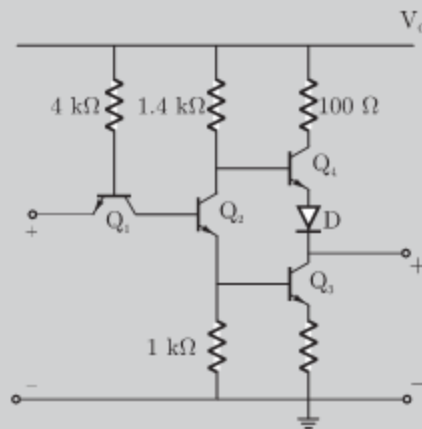

- (A) Q_1 : reverse active; Q_2 : normal active; Q_3 : saturation; Q_4 : cut-off
- (B) Q_1 : reverse active; Q_2 : saturation; Q_3 : saturation; Q_4 : cut-off
- (C) Q_1 : normal active; Q_2 : cut-off; Q_3 : cut-off; Q_4 : saturation
- (D) Q_1 : saturation; Q_2 : saturation; Q_3 : saturation; Q_4 : normal active

Q. 43

The following binary values were applied to the X and Y inputs of NAND latch shown in the figure in the sequence indicated below :

$X = 0, Y = 1; X = 0, Y = 0; X = 1; Y = 1$

The corresponding stable P, Q output will be.

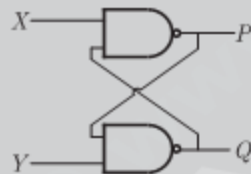

- (A) $P = 1, Q = 0; P = 1, Q = 0; P = 1, Q = 0$ or $P = 0, Q = 1$
- (B) $P = 1, Q = 0; P = 0, Q = 1; P = 0, Q = 1; P = 0, Q = 1$
- (C) $P = 1, Q = 0; P = 1, Q = 1; P = 1, Q = 0$ or $P = 0, Q = 1$
- (D) $P = 1, Q = 0; P = 1, Q = 1; P = 1, Q = 1$

Q. 44

An 8255 chip is interfaced to an 8085 microprocessor system as an I/O mapped I/O as show in the figure. The address lines A_0 and A_1 of the 8085 are used by the 8255 chip to decode internally its three ports and the Control register. The address lines A_3 to A_7 as well as the IO/\overline{M} signal are used for address decoding. The range of addresses for which the 8255 chip would get selected is

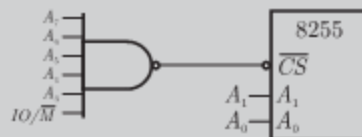

- (A) F8H - FBH
- (B) F8GH - FCH
- (C) F8H - FFH
- (D) F0H - F7H

Statement for Linked Answer Question 45 and 46 :

In the Digital-to-Analog converter circuit shown in the figure below,
 $V_R = 10V$ and $R = 10k\Omega$

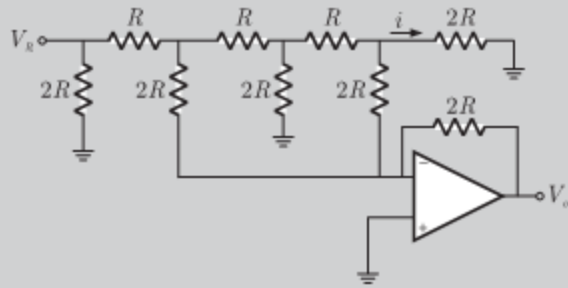

- q. 45 The current is
 (A) $31.25\mu A$ (B) $62.5\mu A$
 (C) $125\mu A$ (D) $250\mu A$
- q. 46 The voltage V_0 is
 (A) $-0.781 V$ (B) $-1.562 V$
 (C) $-3.125 V$ (D) $-6.250 V$

Statement for Linked Answer Questions 47 & 48 :

An 8085 assembly language program is given below.

```

Line 1: MVI A, B5H
        2: MVI B, 0EH
        3: XRI 69H
        4: ADD B
        5: ANI 9BH
        6: CPI 9FH
        7: STA 3010H
        8: HLT
    
```

- q. 47 The contents of the accumulator just execution of the ADD instruction in line 4 will be
 (A) C3H (B) EAH
 (C) DCH (D) 69H
- q. 48 After execution of line 7 of the program, the status of the CY and Z flags will be
 (A) $CY = 0, Z = 0$ (B) $CY = 0, Z = 1$
 (C) $CY = 1, Z = 0$ (D) $CY = 1, Z = 1$
- q. 49 For the circuit shown, the counter state (Q_1Q_0) follows the sequence

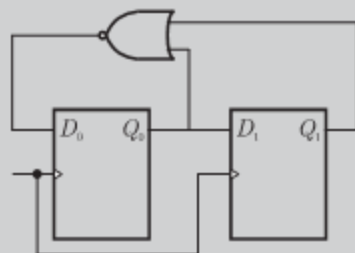

(A) 00,01,10,11,00

(B) 00,01,10,00,01

(C) 00,01,11,00,01

(D) 00,10,11,00,10

2006

ONE MARK

q. 50

The number of product terms in the minimized sum-of-product expression obtained through the following K - map is (where, "d" denotes don't care states)

1	0	0	1
0	d	0	0
0	0	d	1
1	0	0	1

(A) 2

(B) 3

(C) 4

(D) 5

2006

TWO MARKS

q. 51

An I/O peripheral device shown in Fig. (b) below is to be interfaced to an 8085 microprocessor. To select the I/O device in the I/O address range D4 H - D7 H, its chip-select (\overline{CS}) should be connected to the output of the decoder shown in as below :

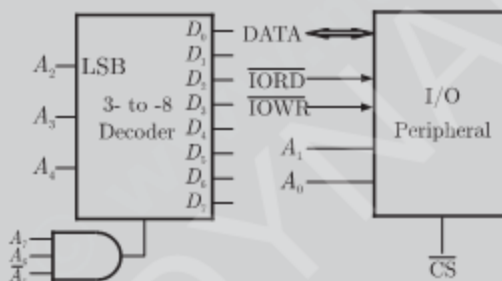

(A) output 7

(B) output 5

(C) output 2

(D) output 0

q. 52

For the circuit shown in figures below, two 4 - bit parallel - in serial - out shift registers loaded with the data shown are used to feed the data to a full adder. Initially, all the flip - flops are in clear state. After applying two clock pulse, the output of the full-adder should be

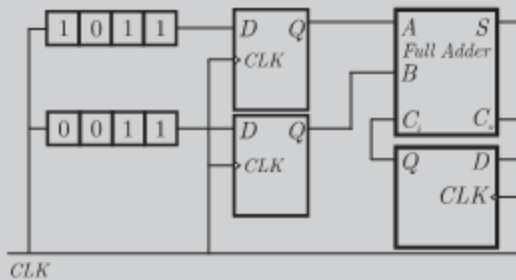

(A) $S = 0, C_0 = 0$

(B) $S = 0, C_0 = 1$

(C) $S = 1, C_0 = 0$

(D) $S = 1, C_0 = 1$

- q. 53 A new Binary Coded Pentary (BCP) number system is proposed in which every digit of a base-5 number is represented by its corresponding 3-bit binary code. For example, the base-5 number 24 will be represented by its BCP code 010100. In this numbering system, the BCP code 10001001101 corresponds of the following number in base-5 system
- (A) 423 (B) 1324
(C) 2201 (D) 4231

- q. 54 A 4 - bit DAC is connected to a free - running 3 - bit UP counter, as shown in the following figure. Which of the following waveforms will be observed at V_o ?

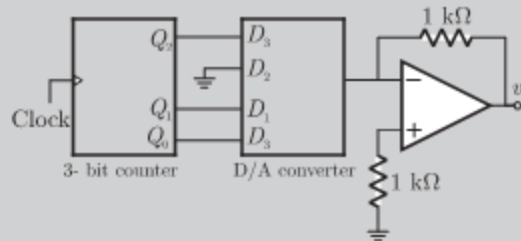

In the figure shown above, the ground has been shown by the symbol ∇

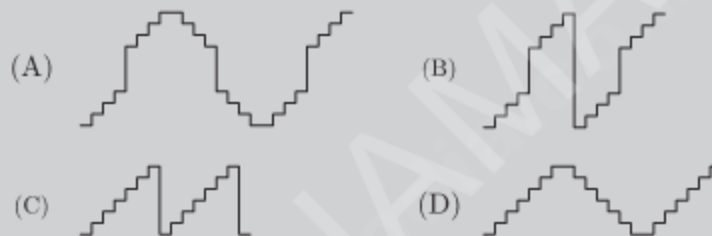

- q. 55 Following is the segment of a 8085 assembly language program

```
LXI SP, EFFF H
CALL 3000 H
:
:
:
:
3000 H LXI H, 3CF4
PUSH PSW
SPHL
POP PSW
RET
```

On completion of RET execution, the contents of SP is

- (A) 3CF0 H (B) 3CF8 H
(C) EFFF H (D) EFFF H
- q. 56 Two D - flip - flops, as shown below, are to be connected as a synchronous counter that goes through the sequence 00 → 01 → 11 → 10 → 00 → ... The inputs D_0 and D_1 respectively should be connected as,

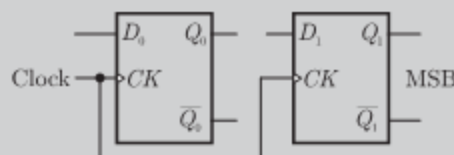

- (A) \bar{Q}_1 and Q_0 (B) \bar{Q}_0 and Q_1
 (C) \bar{Q}_1Q_0 and $\bar{Q}_1\bar{Q}_0$ (D) $\bar{Q}_1\bar{Q}_0$ and Q_1Q_0

q. 57

The point P in the following figure is stuck at 1. The output f will be

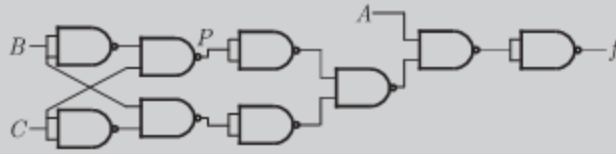

- (A) ABC (B) \bar{A}
 (C) ABC (D) A

2005

ONE MARK

q. 58

Decimal 43 in Hexadecimal and BCD number system is respectively

- (A) B2, 0100 011 (B) 2B, 0100 0011
 (C) 2B, 0011 0100 (D) B2, 0100 0100

q. 59

The Boolean function f implemented in the figure using two input multiplexes is

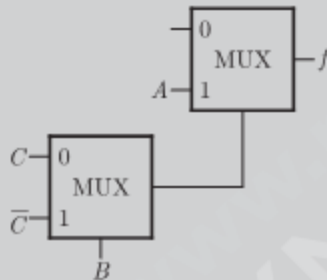

- (A) $A\bar{B}C + ABC$ (B) $ABC + A\bar{B}C$
 (C) $\bar{A}BC + \bar{A}BC$ (D) $\bar{A}BC + \bar{A}BC$

2005

TWO MARKS

q. 60

The transistors used in a portion of the TTL gate show in the figure have $\beta = 100$. The base emitter voltage of is 0.7 V for a transistor in active region and 0.75 V for a transistor in saturation. If the sink current $I = 1$ A and the output is at logic 0, then the current I_R will be equal to

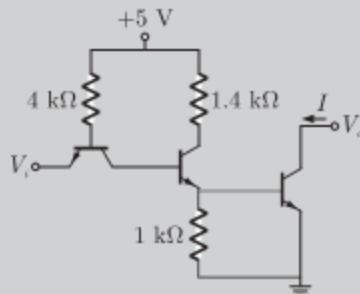

- (A) 0.65 mA (B) 0.70 mA
 (C) 0.75 mA (D) 1.00 mA

Q. 61

The Boolean expression for the truth table shown is

A	B	C	D
0	0	0	0
0	0	1	0
0	1	0	0
0	1	1	1
1	0	0	0
1	0	1	0
1	1	0	1
1	1	1	0

(A) $B(A + C)(\bar{A} + \bar{C})$

(B) $B(A + \bar{C})(\bar{A} + C)$

(C) $\bar{B}(A + \bar{C})(\bar{A} + C)$

(D) $\bar{B}(A + C)(\bar{A} + \bar{C})$

Q. 62

The present output Q_n of an edge triggered JK flip-flop is logic 0. If $J = 1$, then Q_{n+1}

(A) Cannot be determined

(B) Will be logic 0

(C) will be logic 1

(D) will rave around

Q. 63

The given figure shows a ripple counter using positive edge triggered flip-flops. If the present state of the counter is $Q_2Q_1Q_0 = 001$ then is next state $Q_2Q_1Q_0$ will be

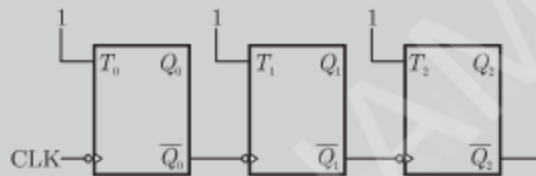

(A) 010

(B) 111

(C) 100

(D) 101

Q. 64

What memory address range is NOT represents by chip # 1 and chip # 2 in the figure A_0 to A_{15} in this figure are the address lines and CS means chip select.

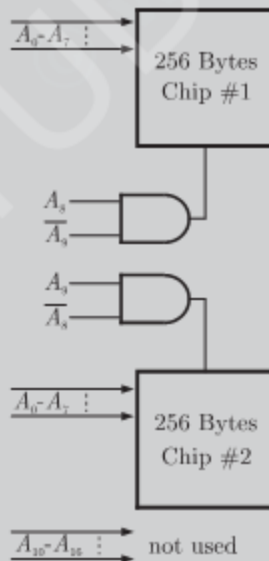

(A) 0100 - 02FF

(B) 1500 - 16FF

(C) F900 - FAFF

(D) F800 - F9FF

Statement For Linked Answer Questions 65 & 66 :

Consider an 8085 microprocessor system.

q. 65 The following program starts at location 0100H.

```
LXI SP, 00FFH
LXI H, 0701
MVI A, 20H
SUB M
```

The content of accumulator when the program counter reaches 0109 H is

- (A) 20 H (B) 02 H
(C) 00 H (D) FF H

q. 66 If in addition following code exists from 019H onwards,

```
ORI 40 H
ADD M
```

What will be the result in the accumulator after the last instruction is executed ?

- (A) 40 H (B) 20 H
(C) 60 H (D) 42 H

2004

ONE MARK

q. 67 A master - slave flip flop has the characteristic that

- (A) change in the output immediately reflected in the output
(B) change in the output occurs when the state of the master is affected
(C) change in the output occurs when the state of the slave is affected
(D) both the master and the slave states are affected at the same time

q. 68 The range of signed decimal numbers that can be represented by 6-bits 1's complement number is

- (A) -31 to +31 (B) -63 to +63
(C) -64 to +63 (D) -32 to +31

q. 69 A digital system is required to amplify a binary-encoded audio signal. The user should be able to control the gain of the amplifier from minimum to a maximum in 100 increments. The minimum number of bits required to encode, in straight binary, is

- (A) 8 (B) 6
(C) 5 (D) 7

q. 70 Choose the correct one from among the alternatives *A, B, C, D* after matching an item from Group 1 most appropriate item in Group 2.

Group 1

Group 2

P. Shift register

1. Frequency division

Q. Counter

2. Addressing in memory chips

R. Decoder

3. Serial to parallel data conversion

(A) $P - 3, Q - 2, R - 1$

(B) $P - 3, Q - 1, R - 2$

(C) $P - 2, Q - 1, R - 3$

(D) $P - 1, Q - 2, R - 2$

q. 71 The figure the internal schematic of a TTL AND-OR-OR-Invert (AOI) gate. For the inputs shown in the figure, the output *Y* is



- (A) 0
(B) 1
(C) AB
(D) \overline{AB}

2004

TWO MARKS

- q. 72 11001, 1001, 111001 correspond to the 2's complement representation of which one of the following sets of number
(A) 25, 9, and 57 respectively
(B) -6, -6, and -6 respectively
(C) -7, -7 and -7 respectively
(D) -25, -9 and -57 respectively

- q. 73 In the modulo-6 ripple counter shown in figure, the output of the 2- input gate is used to clear the J-K flip-flop
The 2-input gate is

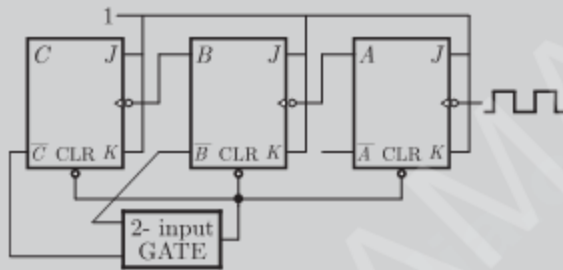

- (A) a NAND gate
(B) a NOR gate
(C) an OR gate
(D) a AND gate

- q. 74 The minimum number of 2- to -1 multiplexers required to realize a 4- to -1 multiplexers is
(A) 1
(B) 2
(C) 3
(D) 4

- q. 75 The Boolean expression $AC + B\overline{C}$ is equivalent to
(A) $\overline{A}C + B\overline{C} + AC$
(B) $\overline{B}C + AC + B\overline{C} + \overline{A}C\overline{B}$
(C) $AC + B\overline{C} + \overline{B}C + ABC$
(D) $ABC + \overline{A}B\overline{C} + ABC\overline{C} + A\overline{B}C$

- q. 76 A Boolean function f of two variables x and y is defined as follows :
 $f(0,0) = f(0,1) = f(1,1) = 1; f(1,0) = 0$
Assuming complements of x and y are not available, a minimum cost solution for realizing f using only 2-input NOR gates and 2- input OR gates (each having unit cost) would have a total cost of
(A) 1 unit
(B) 4 unit
(C) 3 unit
(D) 2 unit

- q. 77 The 8255 Programmable Peripheral Interface is used as described below.
(i) An A/D converter is interface to a microprocessor through an 8255.
The conversion is initiated by a signal from the 8255 on Port C. A signal on Port C causes data to be stobed into Port A.

- (ii) Two computers exchange data using a pair of 8255s. Port A works as a bidirectional data port supported by appropriate handshaking signals. The appropriate modes of operation of the 8255 for (i) and (ii) would be
- (A) Mode 0 for (i) and Mode 1 for (ii)
 - (B) Mode 1 for (i) and Mode 2 for (ii)
 - (C) Mode for (i) and Mode 0 for (ii)
 - (D) Mode 2 for (i) and Mode 1 for (ii)

- q. 78 The number of memory cycles required to execute the following 8085 instructions
- (i) LDA 3000 H
 - (ii) LXI D, FOF1H
- would be
- (A) 2 for (i) and 2 for (ii)
 - (B) 4 for (i) and 3 for (ii)
 - (C) 3 for (i) and 3 for (ii)
 - (D) 3 for (i) and 4 for (ii)

- q. 79 Consider the sequence of 8085 instructions given below
- ```
LXI H, 9258
MOV A, M
CMA
MOV M, A
```
- Which one of the following is performed by this sequence ?
- (A) Contents of location 9258 are moved to the accumulator
  - (B) Contents of location 9258 are compared with the contents of the accumulator
  - (C) Contents of location 8529 are complemented and stored in location 8529
  - (D) Contents of location 5892 are complemented and stored in location 5892

- q. 80 It is desired to multiply the numbers 0AH by 0BH and store the result in the accumulator. The numbers are available in registers B and C respectively. A part of the 8085 program for this purpose is given below :

```
 MVI A, 00H
LOOP -----

 HLT
 END
```

- The sequence of instructions to complete the program would be
- (A) JNX LOOP, ADD B, DCR C
  - (B) ADD B, JNZ LOOP, DCR C
  - (C) DCR C, JNZ LOOP, ADD B
  - (D) ADD B, DCR C, JNZ LOOP

2003

ONE MARK

- q. 81 The number of distinct Boolean expressions of 4 variables is
- (A) 16
  - (B) 256
  - (C) 1023
  - (D) 65536

- q. 82 The minimum number of comparators required to build an 8-bits flash ADC is  
 (A) 8 (B) 63  
 (C) 255 (D) 256
- q. 83 The output of the 74 series of GATE of TTL gates is taken from a BJT in  
 (A) totem pole and common collector configuration  
 (B) either totem pole or open collector configuration  
 (C) common base configuration  
 (D) common collector configuration
- q. 84 Without any additional circuitry, an 8:1 MUX can be used to obtain  
 (A) some but not all Boolean functions of 3 variables  
 (B) all functions of 3 variables but non of 4 variables  
 (C) all functions of 3 variables and some but not all of 4 variables  
 (D) all functions of 4 variables
- q. 85 A 0 to 6 counter consists of 3 flip flops and a combination circuit of 2 input gate  
 (s). The common circuit consists of  
 (A) one AND gate  
 (B) one OR gate  
 (C) one AND gate and one OR gate  
 (D) two AND gates

2003

TWO MARKS

- q. 86 The circuit in the figure has 4 boxes each described by inputs  $P, Q, R$  and outputs  $Y, Z$  with  $Y = P \oplus Q \oplus R$  and  $Z = RQ + \bar{P}R + Q\bar{P}$   
 The circuit acts as a

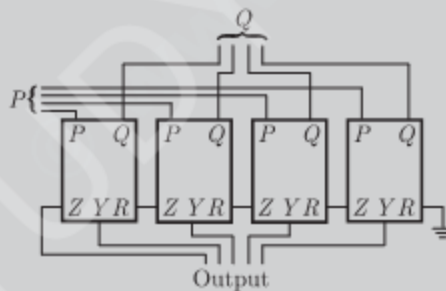

- (A) 4 bit adder giving  $P + Q$   
 (B) 4 bit subtractor giving  $P - Q$   
 (C) 4 bit subtractor giving  $Q - P$   
 (D) 4 bit adder giving  $P + Q + R$
- q. 87 If the function  $W, X, Y$  and  $Z$  are as follows  

$$W = R + \bar{P}Q + \bar{R}S \quad X = P\bar{Q}\bar{R}S + \bar{P}Q\bar{R}S + P\bar{Q}RS$$

$$Y = RS + \bar{P}R + PQ + P.\bar{Q} \quad Z = R + S + PQ + P.\bar{Q}.R + PQ.S$$
 Then,  
 (A)  $W = Z, X = \bar{Z}$  (B)  $W = Z, X = Y$   
 (C)  $W = Y$  (D)  $W = Y = \bar{Z}$

- q. 88 A 4 bit ripple counter and a bit synchronous counter are made using flip flops having a propagation delay of 10 ns each. If the worst case delay in the ripple counter and the synchronous counter be  $R$  and  $S$  respectively, then  
 (A)  $R = 10$  ns,  $S = 40$  ns (B)  $R = 40$  ns,  $S = 10$  ns  
 (C)  $R = 10$  ns  $S = 30$  ns (D)  $R = 30$  ns,  $S = 10$  ns

- q. 89 In the circuit shown in the figure,  $A$  is parallel-in, parallel-out 4 bit register, which loads at the rising edge of the clock  $C$ . The input lines are connected to a 4 bit bus,  $W$ . Its output acts at input to a  $16 \times 4$  ROM whose output is floating when the input to a partial table of the contents of the ROM is as follows

|         |      |      |      |      |      |      |      |      |
|---------|------|------|------|------|------|------|------|------|
| Data    | 0011 | 1111 | 0100 | 1010 | 1011 | 1000 | 0010 | 1000 |
| Address | 0    | 2    | 4    | 6    | 8    | 10   | 11   | 14   |

The clock to the register is shown, and the data on the  $W$  bus at time  $t_1$  is 0110. The data on the bus at time  $t_2$  is

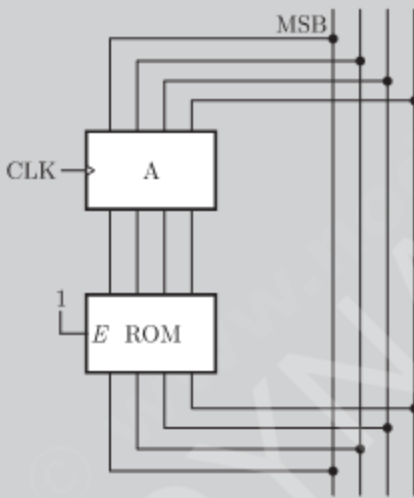

- (A) 1111 (B) 1011  
 (C) 1000 (D) 0010

- q. 90 The DTL, TTL, ECL and CMOS famil GATE of digital ICs are compared in the following 4 columns

|                              | (P)  | (Q)  | (R) | (S)  |
|------------------------------|------|------|-----|------|
| Fanout is minimum            | DTL  | DTL  | TTL | CMOS |
| Power consumption is minimum | TTL  | CMOS | ECL | DTL  |
| Propagation delay is minimum | CMOS | ECL  | TTL | TTL  |

The correct column is

- (A)  $P$  (B)  $Q$   
 (C)  $R$  (D)  $S$

q. 91 The circuit shown in figure converts

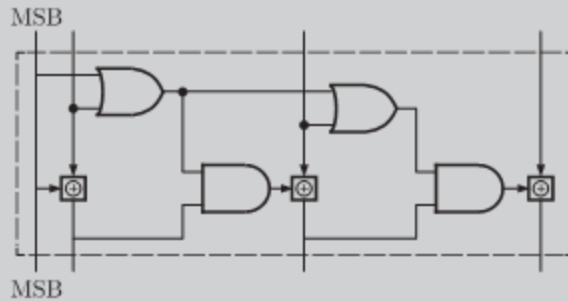

- (A) BCD to binary code (B) Binary to excess - 3 code  
 (C) Excess -3 to gray code (D) Gray to Binary code

q. 92 In an 8085 microprocessor, the instruction CMP B has been executed while the content of the accumulator is less than that of register B. As a result

- (A) Carry flag will be set but Zero flag will be reset  
 (B) Carry flag will be rest but Zero flag will be set  
 (C) Both Carry flag and Zero flag will be rest  
 (D) Both Carry flag and Zero flag will be set

q. 93 The circuit shown in the figure is a 4 bit DAC

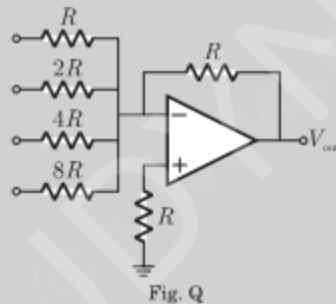

The input bits 0 and 1 are represented by 0 and 5 V respectively. The OP AMP is ideal, but all the resistance and the 5 v inputs have a tolerance of  $\pm 10\%$ . The specification (rounded to nearest multiple of 5%) for the tolerance of the DAC is

(A)  $\pm 35\%$  (B)  $\pm 20\%$   
 (C)  $\pm 10\%$  (D)  $\pm 5\%$

2002

ONE MARK

q. 94 4 - bit 2's complement representation of a decimal number is 1000. The number is

- (A) +8 (B) 0  
 (C) -7 (D) -8

q. 95 The number of comparators required in a 3-bit comparators type ADC

- (A) 2 (B) 3  
 (C) 7 (D) 8



- q. 96 If the input to the digital circuit (in the figure) consisting of a cascade of 20 XOR-gates is  $X$ , then the output  $Y$  is equal to

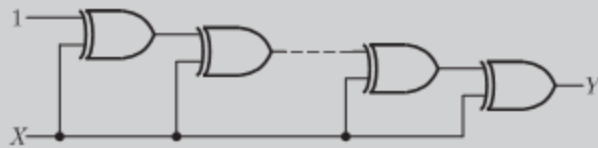

- (A) 0 (B) 1  
(C)  $\bar{X}$  (D)  $X$

2002

TWO MARKS

- q. 97 The gates  $G_1$  and  $G_2$  in the figure have propagation delays of 10 ns and 20 ns respectively. If the input  $V_1$ , makes an output change from logic 0 to 1 at time  $t = t_0$ , then the output waveform  $V_0$  is

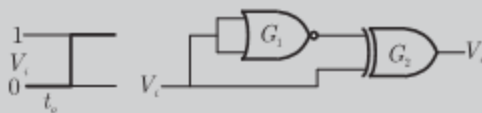

- (A) (B)   
(C) (D)

- q. 98 If the input  $X_3, X_2, X_1, X_0$  to the ROM in the figure are 8 4 2 1 BCD numbers, then the outputs  $Y_3, Y_2, Y_1, Y_0$  are

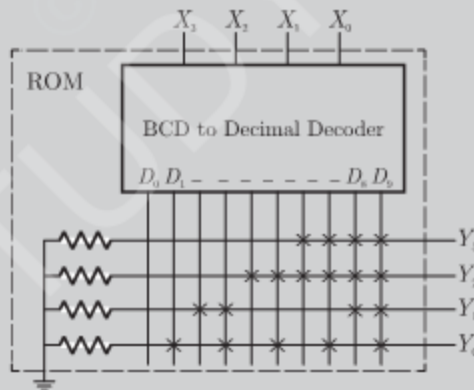

- (A) gray code numbers (B) 2 4 2 1 BCD numbers  
(C) excess - 3 code numbers (D) none of the above

- q. 99 Consider the following assembly language program

```
MVI B, 87H
MOV A, B
START : JMP NEXT
MVI B, 00H
XRA B
```



```

OUT PORT1
HLT
NEXT : XRA B
 JP START
 OUT PORT2
 HTL

```

The execution of above program in an 8085 microprocessor will result in

- (A) an output of 87H at PORT1
- (B) an output of 87H at PORT2
- (C) infinite looping of the program execution with accumulator data remaining at 00H
- (D) infinite looping of the program execution with accumulator data alternating between 00H and 87H

q. 100 The circuit in the figure has two CMOS NOR gates. This circuit functions as a:

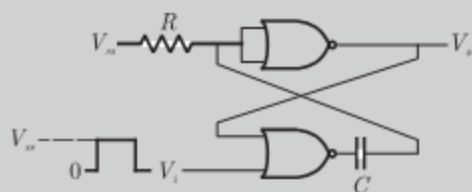

- (A) flip-flop
- (B) Schmitt trigger
- (C) Monostable multivibrator
- (D) astable multivibrator

2001

ONE MARKS

q. 101 The 2's complement representation of -17 is

- (A) 101110
- (B) 101111
- (C) 111110
- (D) 110001

q. 102 For the ring oscillator shown in the figure, the propagation delay of each inverter is 100 pico sec. What is the fundamental frequency of the oscillator output



- (A) 10 MHz
- (B) 100 MHz
- (C) 1 GHz
- (D) 2 GHz

q. 103 An 8085 microprocessor based system uses a  $4K \times 8$  bit RAM whose starting address is AA00H. The address of the last byte in this RAM is

- (A) OFFFH
- (B) 1000H
- (C) B9FFH
- (D) BA00H

2001

TWO MARKS

q. 104 In the TTL circuit in the figure,  $S_2$  and  $S_0$  are select lines and  $X_7$  and  $X_0$  are input lines.  $S_0$  and  $X_0$  are LSBs. The output  $Y$  is

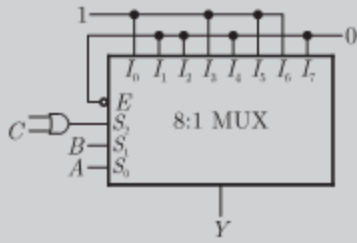

- (A) indeterminate (B)  $A \oplus B$   
 (C)  $\overline{A \oplus B}$  (D)  $\overline{C(A \oplus B)} + C(A \oplus B)$

Q. 105

The digital block in the figure is realized using two positive edge triggered D-flip-flop. Assume that for  $t < t_0, Q_1 = Q_2 = 0$ . The circuit in the digital block is given by



- (A)
- (B)
- (C)
- (D)

Q. 106

In the DRAM cell in the figure, the  $V_t$  of the NMOSFET is 1 V. For the following three combinations of WL and BL voltages.

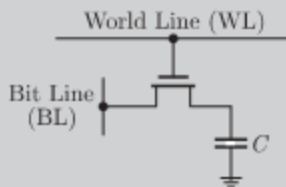

- (A) 5 V; 3 V; 7 V  
 (B) 4 V; 3 V; 4 V  
 (C) 5 V; 5 V; 5 V  
 (D) 4 V; 4 V; 4 V

Q. 107

In the figure, the LED

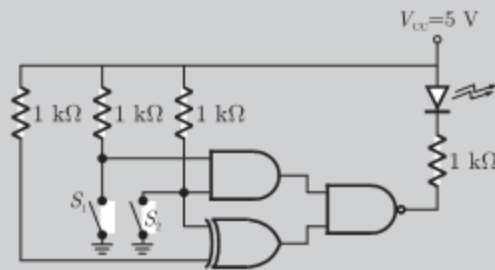

- (A) emits light when both  $S_1$  and  $S_2$  are closed
- (B) emits light when both  $S_1$  and  $S_2$  are open
- (C) emits light when only of  $S_1$  and  $S_2$  is closed
- (D) does not emit light, irrespective of the switch positions.

2000

ONE MARKS

Q. 108

An 8 bit successive approximation analog to digital communication has full scale reading of 2.55 V and its conversion time for an analog input of 1 V is  $20 \mu s$ . The conversion time for a 2 V input will be

- (A)  $10 \mu s$
- (B)  $20 \mu s$
- (C)  $40 \mu s$
- (D)  $50 \mu s$

Q. 109

The number of comparator in a 4-bit flash ADC is

- (A) 4
- (B) 5
- (C) 15
- (D) 16

Q. 110

For the logic circuit shown in the figure, the required input condition ( $A, B, C$ ) to make the output ( $X$ ) = 1 is

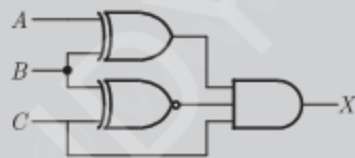

- (A) 1,0,1
- (B) 0,0,1
- (C) 1,1,1
- (D) 0,1,1

Q. 111

The number of hardware interrupts (which require an external signal to interrupt) present in an 8085 microprocessor are

- (A) 1
- (B) 4
- (C) 5
- (D) 13

Q. 112

In the microprocessor, the RST6 instruction transfer the program execution to the following location :

- (A) 30 H
- (B) 24 H
- (C) 48 H
- (D) 60 H

- q. 113 The contents of register (B) and accumulator (A) of 8085 microprocessor are 49H and 3AH respectively. The contents of A and status of carry (CY) and sign (S) after execution SUB B instructions are  
 (A) A = F1, CY = 1, S = 1 (B) A = 0F, CY = 1, S = 1  
 (C) A = F0, CY = 0, S = 0 (D) A = 1F, CY = 1, S = 1

- q. 114 For the logic circuit shown in the figure, the simplified Boolean expression for the output Y is

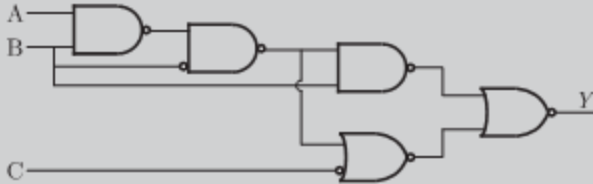

- (A)  $A + B + C$  (B)  $A$   
 (C)  $B$  (D)  $C$
- q. 115 For the 4 bit DAC shown in the figure, the output voltage  $V_0$  is

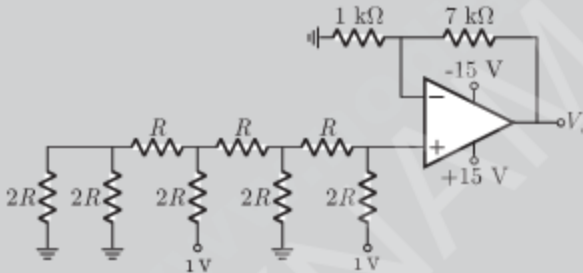

- (A) 10 V (B) 5 V  
 (C) 4 V (D) 8 V
- q. 116 A sequential circuit using D flip-flop and logic gates is shown in the figure, where X and Y are the inputs and Z is the outputs. The circuit is

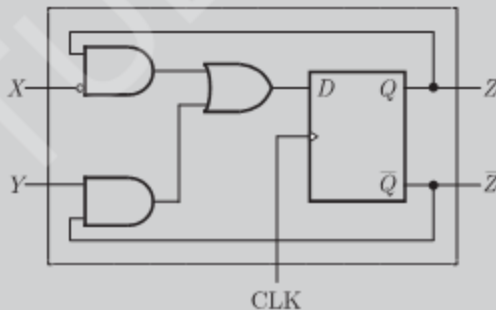

- (A) S-R Flip-Flop with inputs  $X = R$  and  $Y = S$   
 (B) S-R Flip-Flop with inputs  $X = S$  and  $Y = R$   
 (C) J-K Flip-Flop with inputs  $X = J$  and  $Y = K$   
 (D) J-K Flip-Flop with input  $X = K$  and  $Y = J$
- q. 117 In the figure, the J and K inputs of all the four Flip-Flops are made high. The frequency of the signal at output Y is

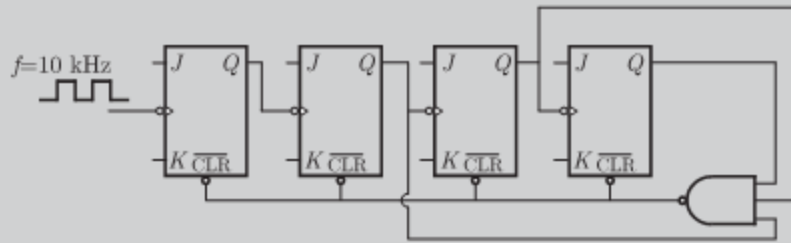

- (A) 0.833 kHz  
(B) 1.0 kHz  
(C) 0.91 kHz  
(D) 0.77 kHz

1999

ONE MARK

- q. 118 The logical expression  $y = A + \bar{A}B$  is equivalent to  
(A)  $y = AB$   
(B)  $y = \bar{A}B$   
(C)  $y = \bar{A} + B$   
(D)  $y = A + B$
- q. 119 A Darlington emitter follower circuit is sometimes used in the output stage of a TTL gate in order to  
(A) increase its  $I_{OL}$   
(B) reduce its  $I_{OH}$   
(C) increase its speed of operation  
(D) reduce power dissipation
- q. 120 Commercially available ECL gears use two ground lines and one negative supply in order to  
(A) reduce power dissipation  
(B) increase fan-out  
(C) reduce loading effect  
(D) eliminate the effect of power line glitches or the biasing circuit
- q. 121 The resolution of a 4-bit counting ADC is 0.5 volts. For an analog input of 6.6 volts, the digital output of the ADC will be  
(A) 1011  
(B) 1101  
(C) 1100  
(D) 1110

1999

TWO MARKS

- q. 122 The minimized form of the logical expression  $(\bar{A}\bar{B}\bar{C} + \bar{A}B\bar{C} + \bar{A}BC + ABC)$  is  
(A)  $\bar{A}\bar{C} + B\bar{C} + \bar{A}B$   
(B)  $A\bar{C} + \bar{B}C + \bar{A}B$   
(C)  $\bar{A}C + \bar{B}C + \bar{A}B$   
(D)  $A\bar{C} + \bar{B}C + AB$
- q. 123 For a binary half-subtractor having two inputs A and B, the correct set of logical expressions for the outputs  $D (= A \text{ minus } B)$  and  $X (= \text{borrow})$  are  
(A)  $D = AB + \bar{A}B, X = \bar{A}B$   
(B)  $D = \bar{A}B + A\bar{B} + A\bar{B}, X = A\bar{B}$   
(C)  $D = \bar{A}B + A\bar{B}, X = \bar{A}B$   
(D)  $D = AB + \bar{A}B, X = A\bar{B}$

- Q. 124 If  $CS = A_{15}A_{14}A_{13}$  is used as the chip select logic of a 4 K RAM in an 8085 system, then its memory range will be  
 (A) 3000 H - 3 FFF H  
 (B) 7000 H - 7 FFF H  
 (C) 5000 H - 5 FFF H and 6000 H - 6 FFF H  
 (D) 6000 H - 6 FFF H and 7000 H - 7 FFF H

- Q. 125 The ripple counter shown in the given figure is works as a

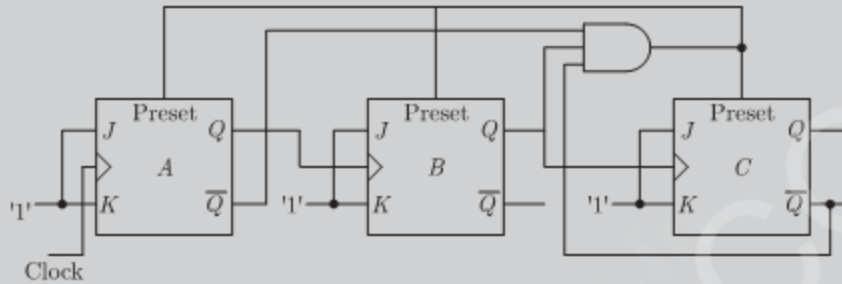

- (A) mod-3 up counter  
 (B) mod-5 up counter  
 (C) mod-3 down counter  
 (D) mod-5 down counter

1998

ONE MARK

- Q. 126 The minimum number of 2-input NAND gates required to implement of Boolean function  $Z = A\bar{B}C$ , assuming that A, B and C are available, is  
 (A) two  
 (B) three  
 (C) five  
 (D) six
- Q. 127 The noise margin of a TTL gate is about  
 (A) 0.2 V  
 (B) 0.4 V  
 (C) 0.6 V  
 (D) 0.8 V
- Q. 128 In the figure is  $A = 1$  and  $B = 1$ , the input B is now replaced by a sequence 101010....., the output x and y will be



- (A) fixed at 0 and 1, respectively  
 (B)  $x = 1010$ .....while  $y = 0101$ .....  
 (C)  $x = 1010$ .....and  $y = 1010$ .....  
 (D) fixed at 1 and 0, respectively
- Q. 129 An equivalent 2's complement representation of the 2's complement number 1101 is  
 (A) 110100  
 (B) 01101  
 (C) 110111  
 (D) 111101

- q. 130 The threshold voltage for each transistor in the figure is 2 V. For this circuit to work as an inverter,  $V_i$  must take the values

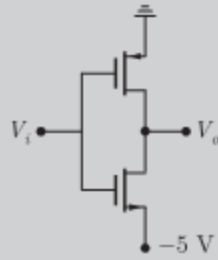

- (A) -5 V and 0 V  
(B) -5 V and 5 V  
(C) -0 V and 3 V  
(D) 3 V and 5 V
- q. 131 An *I/O* processor control the flow of information between  
(A) cache memory and *I/O* devices  
(B) main memory and *I/O* devices  
(C) two *I/O* devices  
(D) cache and main memories
- q. 132 Two 2's complement number having sign bits  $x$  and  $y$  are added and the sign bit of the result is  $z$ . Then, the occurrence of overflow is indicated by the Boolean function  
(A)  $xyz$   
(B)  $\bar{x}\bar{y}\bar{z}$   
(C)  $\bar{x}\bar{y}z + xy\bar{z}$   
(D)  $xy + yz + zx$
- q. 133 The advantage of using a dual slope ADC in a digital voltmeter is that  
(A) its conversion time is small  
(B) its accuracy is high  
(C) it gives output in BCD format  
(D) it does not require a
- q. 134 For the identity  $AB + \bar{A}C + BC = AB + \bar{A}C$ , the dual form is  
(A)  $(A + B)(\bar{A} + C)(B + C) = (A + B)(\bar{A} + C)$   
(B)  $(\bar{A} + \bar{B})(A + \bar{C})(\bar{B} + \bar{C}) = (\bar{A} + \bar{B})(A + \bar{C})$   
(C)  $(A + B)(\bar{A} + C)(B + C) = (\bar{A} + \bar{B})(A + \bar{C})$   
(D)  $\bar{A}\bar{B} + A\bar{C} + \bar{B}\bar{C} = \bar{A}\bar{B} + A\bar{C}$
- q. 135 An instruction used to set the carry Flag in a computer can be classified as  
(A) data transfer  
(B) arithmetic  
(C) logical  
(D) program control
- q. 136 The figure is shows a mod-K counter, here K is equal to

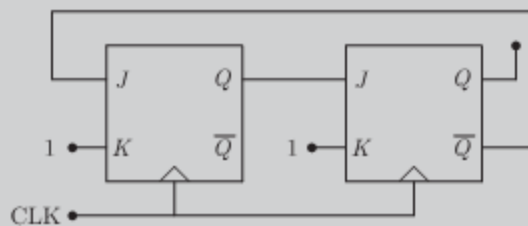

- (A) 1 (B) 2  
(C) 3 (D) 4

q. 137 The current  $I$  through resistance  $r$  in the circuit shown in the figure is

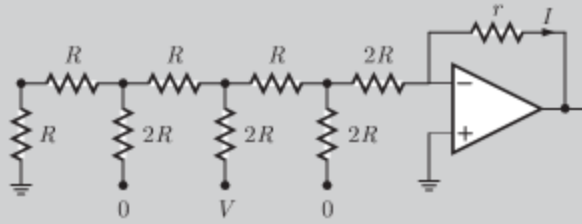

- (A)  $\frac{-V}{12R}$  (B)  $\frac{V}{12R}$   
(C)  $\frac{V}{6R}$  (D)  $\frac{V}{3T}$

q. 138 The  $K$ -map for a Boolean function is shown in the figure is the number of essential prime implicants for this function is

|      |      |    |    |    |
|------|------|----|----|----|
|      | $AB$ |    |    |    |
| $CD$ | 00   | 01 | 11 | 10 |
| 00   | 1    | 1  |    | 1  |
| 01   |      |    |    | 1  |
| 11   | 1    |    |    |    |
| 10   | 1    |    |    | 1  |

- (A) 4 (B) 5  
(C) 6 (D) 8

1997

ONE MARK

q. 139 Each cell of a static Random Access Memory contains

- (A) 6 MOS transistors  
(B) 4 MOS transistors and 2 capacitors  
(C) 2 MOS transistors and 4 capacitors  
(D) 1 MOS transistors and 1 capacitors

q. 140 A 2 bit binary multiplier can be implemented using

- (A) 2 inputs ANSs only  
(B) 2 input XORs and 4 input AND gates only  
(C) Two 2 inputs NORs and one XNO gate  
(D) XOR gates and shift registers

q. 141 In standard TTL, the 'totem pole' stage refers to

- (A) the multi-emitter input stage  
(B) the phase splitter  
(C) the output buffer  
(D) open collector output stage



Q. 142

The inverter 74 ALS04 has the following specifications

$$I_{OHmax} = -0.4 \text{ A}, I_{OLmax} = 8 \text{ mA}, I_{IHmax} = 20 \text{ mA}, I_{ILmax} = -0.1 \text{ mA}$$

The fan out based on the above will be

- (A) 10 (B) 20  
(C) 60 (D) 100

Q. 143

The output of the logic gate in the figure is

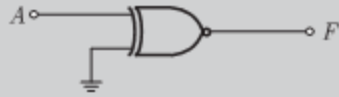

- (A) 0 (B) 1  
(C) A (D) F

Q. 144

In an 8085  $\mu\text{P}$  system, the RST instruction will cause an interrupt

- (A) only if an interrupt service routine is not being executed  
(B) only if a bit in the interrupt mask is made 0  
(C) only if interrupts have been enabled by an EI instruction  
(D) None of the above

Q. 145

The decoding circuit shown in the figure is has been used to generate the active low chip select signal for a microprocessor peripheral. (The address lines are designated as  $A_0$  to  $A_7$  for  $I/O$  address)

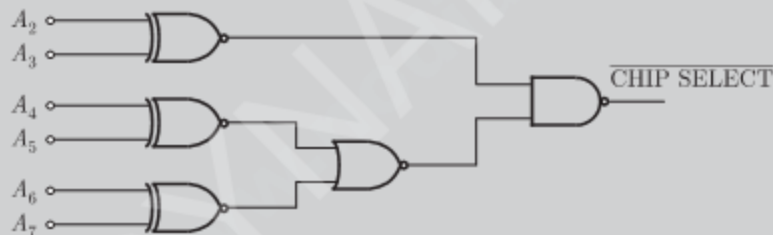

The peripheral will correspond to  $I/O$  address in the range

- (A) 60 H to 63 H (B) A4 to A 7H  
(C) 30 H to 33 H (D) 70 H to 73 H

Q. 146

The following instructions have been executed by an 8085  $\mu\text{P}$

| ADDRESS (HEX) | INSTRUCTION     |
|---------------|-----------------|
| 6010          | LXI H, 8 A 79 H |
| 6013          | MOV A, L        |
| 6015          | ADDH            |
| 6016          | DAA             |
| 6017          | MOV H, A        |
| 6018          | PCHL            |

From which address will the next instruction be fetched ?

- (A) 6019 (B) 6379  
(C) 6979 (D) None of the above

Q. 147

A signed integer has been stored in a byte using the 2's complement format. We wish to store the same integer in a 16 bit word. We should

- (A) copy the original byte to the less significant byte of the word and fill the more significant with zeros
- (B) copy the original byte to the more significant byte of the word and fill the less significant byte with zeros
- (C) copy the original byte to the less significant byte of the word and make each bit of the more significant byte equal to the most significant bit of the original byte
- (D) copy the original byte to the less significant byte as well as the more significant byte of the word

1997

TWO MARKS

Q. 148

For the NMOS logic gate shown in the figure is the logic function implemented is

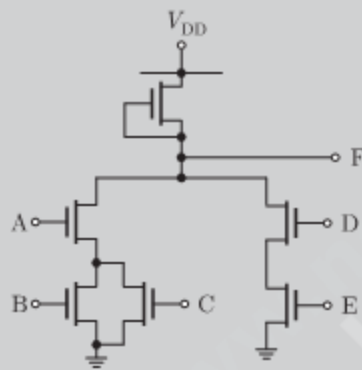

- (A)  $\overline{ABCDE}$
- (B)  $(AB + \overline{C}) \cdot (\overline{D} + \overline{E})$
- (C)  $\overline{A \cdot (B + C) + D \cdot E}$
- (D)  $(A + B) \cdot C + \overline{D} \cdot \overline{E}$

Q. 149

In a J-K flip-flop we have  $J = Q$  and  $K = 1$ . Assuming the flip flop was initially cleared and then clocked for 6 pulses, the sequence at the Q output will be

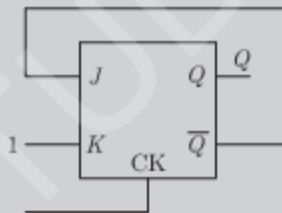

- (A) 010000
- (B) 011001
- (C) 010010
- (D) 010101

Q. 150

The gate delay of an NMOS inverter is dominated by charge time rather than discharge time because

- (A) the driver transistor has larger threshold voltage than the load transistor
- (B) the driver transistor has larger leakage currents compared to the load transistor
- (C) the load transistor has a smaller  $W/L$  ratio compared to the driver transistor

(D) none of the above

q. 151

The boolean function  $A + BC$  is a reduced form of

- (A)  $AB + BC$  (B)  $(A + B) \cdot (A + C)$   
(C)  $\overline{A}B + A\overline{B}C$  (D)  $(A + C) \cdot B$

1996

ONE MARK

q. 152

Schottky clamping is resorted in TTL gates

- (A) to reduce propagation delay (B) to increase noise margins  
(C) to increase packing density (D) to increase fan-out

q. 153

A pulse train can be delayed by a finite number of clock periods using

- (A) a serial-in serial-out shift register  
(B) a serial-in parallel-out shift register  
(C) a parallel-in serial-out shift register  
(D) a parallel-in parallel-out shift register

q. 154

A 12-bit ADC is operating with a  $1\mu\text{sec}$  clock period and the total conversion time is seen to be  $14\mu\text{sec}$ . The ADC must be of the

- (A) flash type (B) counting type  
(C) intergrating type (D) successive approximation type

q. 155

The total number of memory accesses involved (inclusive of the op-code fetch) when an 8085 processor executes the instruction LDA 2003 is

- (A) 1 (B) 2  
(C) 3 (D) 4

1996

TWO MARKS

q. 156

A dynamic RAM cell which hold 5 V has to be refreshed every 20 m sec, so that the stored voltage does not fall by more than 0.5 V. If the cell has a constant discharge current of 1 pA, the storage capacitance of the cell is

- (A)  $4 \times 10^{-6}$  F (B)  $4 \times 10^{-9}$  F  
(C)  $4 \times 10^{-12}$  F (D)  $4 \times 10^{-15}$  F

q. 157

A 10-bit ADC with a full scale output voltage of 10.24 V is designed to have a  $\pm\text{LSB}/2$  accuracy. If the ADC is calibrated at  $25^\circ\text{C}$  and the operating temperature ranges from  $0^\circ\text{C}$  to  $25^\circ\text{C}$ , then the maximum net temperature coefficient of the ADC should not exceed

- (A)  $\pm 200\mu\text{V}/^\circ\text{C}$  (B)  $\pm 400\mu\text{V}/^\circ\text{C}$   
(C)  $\pm 600\mu\text{V}/^\circ\text{C}$  (D)  $\pm 800\mu\text{V}/^\circ\text{C}$

q. 158

A memory system of size 26 K bytes is required to be designed using memory chips which have 12 address lines and 4 data lines each. The number of such chips required to design the memory system is

- (A) 2 (B) 4  
(C) 8 (D) 13

Q. 159

The following sequence of instructions are executed by an 8085 microprocessor:

1000        LXI SP, 27 FF

1003        CALL 1006

1006        POP H

The contents of the stack pointer (SP) and the HL, register pair on completion of execution of these instruction are

(A) SP = 27 FF, HL = 1003

(B) SP = 27 FD, HL = 1003

(C) SP = 27 FF, HL = 1006

(D) SP = 27 FD, HL = 1006

\*\*\*\*\*

# SOLUTIONS

Sol. 1

Option (C) is correct.

Let  $A$  denotes the position of switch at ground floor and  $B$  denotes the position of switch at upper floor. The switch can be either in up position or down position. Following are the truth table given for different combinations of  $A$  and  $B$

| A       | B       | Y(Bulb) |
|---------|---------|---------|
| up(1)   | up(1)   | OFF(0)  |
| Down(0) | Down(0) | OFF(0)  |
| up(1)   | Down(0) | ON(1)   |
| Down(0) | up(1)   | ON(1)   |

When the switches  $A$  and  $B$  are both up or both down, output will be zero (i.e. Bulb will be OFF). Any of the switch changes its position leads to the ON state of bulb. Hence, from the truth table, we get

$$Y = A \oplus B$$

i.e., the XOR gate

Sol. 2

Option (A) is correct.

The program is being executed as follows

MVI A, 05H;      A = 05H

MVI B, 05H;      B = 05H

At the next instruction, a loop is being introduced in which for the instruction "DCR B" if the result is zero then it exits from loop so, the loop is executed five times as follows :

| Content in B | Output of ADD B (Stored value at A) |
|--------------|-------------------------------------|
| 05           | 05 + 05                             |
| 04           | 05 + 05 + 04                        |
| 03           | 05 + 05 + 04 + 03                   |
| 02           | 05 + 05 + 04 + 03 + 02              |
| 01           | 05 + 05 + 04 + 03 + 02 + 01         |
| 00           | System is out of loop               |

i.e.,  $A = 05 + 05 + 04 + 03 + 02 + 01 = 144$

At this stage, the 8085 microprocessor exits from the loop and reads the next instruction. i.e., the accumulator is being added to 03 H. Hence, we obtain

$$A = A + 03 \text{ H} = 14 + 03 = 17 \text{ H}$$

Sol. 3

Option (D) is correct.

For chip-1, we have the following conclusions:

it is enable when (i)  $S_1 S_0 = 0 \ 0$

and (ii)  $\text{Input} = 1$

For  $S_1 S_0 = 0 \ 0$

We have  $A_{13} = A_{12} = 0$

and for  $I/p = 1$  we obtain

$$\bar{A}_{10} = 1 \text{ or } A_{10} = 0$$

$$A_{11} = 1$$

$$\bar{A}_{14} = 1 \text{ or } A_{14} = 0$$

$$\bar{A}_{15} = 1 \text{ or } A_{15} = 0$$

Since,  $A_0 - A_9$  can have any value 0 or 1

Therefore, we have the address range as

|      | $A_{15}$ | $A_{14}$ | $A_{13}$ | $A_{12}$ | $A_{11}$ | $A_{10}$ | $A_9$ | $A_8$ | $A_7$ | $A_6$ | $A_5$ | $A_4$ | $A_3$ | $A_2$ | $A_1$ | $A_0$ |
|------|----------|----------|----------|----------|----------|----------|-------|-------|-------|-------|-------|-------|-------|-------|-------|-------|
| From | 0        | 0        | 0        | 0        | 1        | 0        | 0     | 0     | 0     | 0     | 0     | 0     | 0     | 0     | 0     | 0     |
| to   | 0        | 0        | 0        | 0        | 1        | 0        | 1     | 1     | 1     | 1     | 1     | 1     | 1     | 1     | 1     | 1     |

In Hexadecimal  $\Rightarrow$  0800 H to 0BFFH

Similarly, for chip 2, we obtain the range as follows

$$E = 1 \text{ for } S_1 S_0 = 0 \ 1$$

so,  $A_{13} = 0$  and  $A_{12} = 1$

and also the  $I/P = 1$  for

$$A_{10} = 0, A_{11} = 1, A_{14} = 0, A_{15} = 0$$

so, the fixed I/ps are

| $A_{15}$ | $A_{14}$ | $A_{13}$ | $A_{12}$ | $A_{11}$ | $A_{10}$ |
|----------|----------|----------|----------|----------|----------|
| 0        | 0        | 0        | 1        | 1        | 0        |

Therefore, the address range is

|      | $A_{15}$ | $A_{14}$ | $A_{13}$ | $A_{12}$ | $A_{11}$ | $A_{10}$ | $A_9$ | $A_8$ | $A_7$ | $A_6$ | $A_5$ | $A_4$ | $A_3$ | $A_2$ | $A_1$ | $A_0$ |
|------|----------|----------|----------|----------|----------|----------|-------|-------|-------|-------|-------|-------|-------|-------|-------|-------|
| From | 0        | 0        | 0        | 1        | 1        | 0        | 0     | 0     | 0     | 0     | 0     | 0     | 0     | 0     | 0     | 0     |
| to   | 0        | 0        | 0        | 1        | 1        | 0        | 1     | 1     | 1     | 1     | 1     | 1     | 1     | 1     | 1     | 1     |

In hexadecimal it is from 1800 H to 1BFFH. There is no need to obtain rest of address ranged as only (D) is matching to two results.

Sol. 4

Option (A) is correct.

The given circuit is

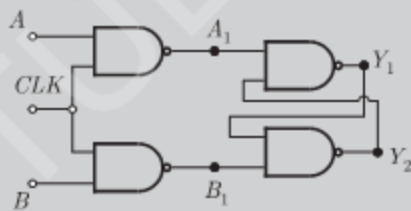

Condition for the race-around

It occurs when the output of the circuit ( $Y_1, Y_2$ ) oscillates between '0' and '1' checking it from the options.

1. Option (A): When  $CLK = 0$

Output of the NAND gate will be  $A_1 = B_1 = \bar{0} = 1$ . Due to these input to the next NAND gate,  $Y_2 = \bar{Y_1} \cdot \bar{1} = \bar{Y_1}$  and  $Y_1 = \bar{Y_2} \cdot \bar{1} = \bar{Y_2}$ .

If  $Y_1 = 0$ ,  $Y_2 = \bar{Y_1} = 1$  and it will remain the same and doesn't oscillate.

If  $Y_2 = 0$ ,  $Y_1 = \bar{Y_2} = 1$  and it will also remain the same for the clock period. So, it won't oscillate for  $CLK = 0$ .

So, here race around doesn't occur for the condition  $CLK = 0$ .

2. Option (C): When  $CLK = 1, A = B = 1$

$$A_1 = B_1 = 0 \text{ and so } Y_1 = Y_2 = 1$$

And it will remain same for the clock period. So race around doesn't occur for the condition.

3. Option (D): When  $CLK = 1, A = B = 0$

So,  $A_1 = B_1 = 1$

And again as described for Option (B) race around doesn't occur for the condition.

Sol. 5

Option (B) is correct.

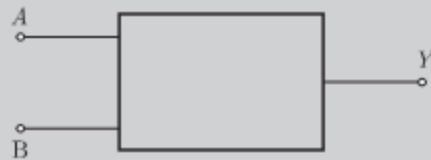

$$Y = 1, \text{ when } A > B$$

$$A = a_1a_0, B = b_1b_0$$

| $a_1$ | $a_0$ | $b_1$ | $b_0$ | $Y$ |
|-------|-------|-------|-------|-----|
| 0     | 1     | 0     | 0     | 1   |
| 1     | 0     | 0     | 0     | 1   |
| 1     | 0     | 0     | 1     | 1   |
| 1     | 1     | 0     | 0     | 1   |
| 1     | 1     | 0     | 1     | 1   |
| 1     | 1     | 1     | 0     | 1   |

Total combination = 6

Sol. 6

Option (A) is correct.

Parallel connection of MOS  $\Rightarrow$  OR operation

Series connection of MOS  $\Rightarrow$  AND operation

The pull-up network acts as an inverter. From pull down network we write

$$Y = \overline{(A + B)C} = \overline{(A + B)} + \overline{C} = \overline{A} \overline{B} + \overline{C}$$

Sol. 7

Option (A) is correct.

Prime implicants are the terms that we get by solving K-map

|     |   |      |    |    |    |
|-----|---|------|----|----|----|
|     |   | $YZ$ |    |    |    |
|     |   | 00   | 01 | 11 | 10 |
| $X$ | 1 | 1    | 1  |    |    |
|     | 0 |      |    | 1  | 1  |

$$F = \underbrace{XY + \overline{X}Y}_{\text{prime implicants}}$$

Sol. 8

Option (D) is correct.

Let  $Q_{n+1}$  is next state and  $Q_n$  is the present state. From the given below figure.

$$D = Y = \overline{A}X_0 + AX_1$$

$$Q_{n+1} = D = \overline{A}X_0 + AX_1$$

$$Q_{n+1} = \overline{A} \overline{Q}_n + AQ_n$$

$$X_0 = \overline{Q}, X_1 = Q$$

If  $A = 0$ ,  $Q_{n+1} = \overline{Q_n}$  (toggle of previous state)

If  $A = 1$ ,  $Q_{n+1} = Q_n$

So state diagram is

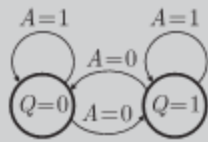

Sol. 9

Option (B) is correct.

The given circuit is shown below:

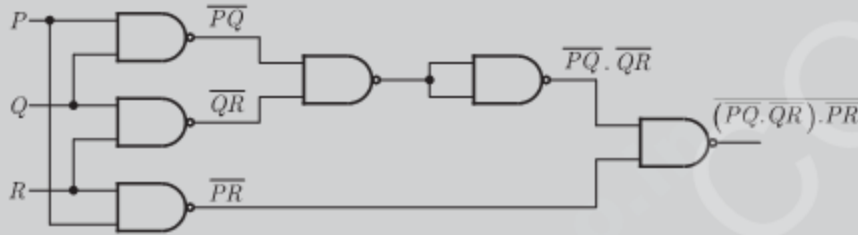

$$\overline{(P\overline{Q} \overline{QR}) \overline{PR}} = \overline{P\overline{Q} + \overline{QR} \overline{PR}} = \overline{P\overline{Q}} + \overline{\overline{QR}} + \overline{\overline{PR}} = PQ + QR + PR$$

If any two or more inputs are '1' then output  $y$  will be 1.

Sol. 10

Option (A) is correct.

For the output to be high, both inputs to AND gate should be high.

The D-Flip Flop output is the same, after a delay.

Let initial input be 0;

(Consider Option A)

then  $\overline{Q} = 1$  (For 1<sup>st</sup> D-Flip Flop). This is given as input to 2<sup>nd</sup> FF.

Let the second input be 1. Now, considering after 1 time interval; The output of 1<sup>st</sup> Flip Flop is 1 and 2<sup>nd</sup> FF is also 1. Thus Output = 1.

Sol. 11

Option (D) is correct.

$$F = \overline{S_1} \overline{S_0} I_0 + \overline{S_1} S_0 I_1 + S_1 \overline{S_0} I_2 + S_1 S_0 I_3$$

$$I_0 = I_3 = 0$$

$$F = \overline{P}Q + P\overline{Q} = \text{XOR}(P, Q)$$

$$(S_1 = P, S_0 = Q)$$

Sol. 12

Option (A) is correct.

All the states of the counter are initially unset.

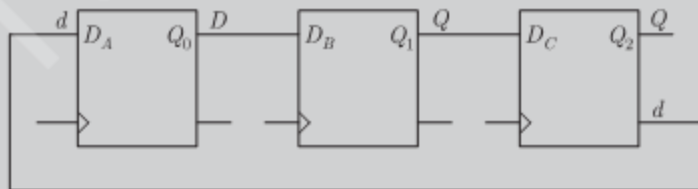

State Initially are shown below in table :

| $Q_2$ | $Q_1$ | $Q_0$ |   |
|-------|-------|-------|---|
| 0     | 0     | 0     | 0 |
| 1     | 0     | 0     | 4 |
| 1     | 1     | 0     | 6 |
| 1     | 1     | 1     | 7 |



|   |   |   |   |
|---|---|---|---|
| 0 | 1 | 1 | 3 |
| 0 | 0 | 1 | 1 |
| 0 | 0 | 0 | 0 |

Sol. 13

Option (D) is correct.

The sequence is  $Q_B Q_A$

$00 \rightarrow 11 \rightarrow 01 \rightarrow 10 \rightarrow 00 \rightarrow \dots$

| $Q_B$ | $Q_A$ | $Q_B(t+1)$ | $Q_A(t+1)$ |
|-------|-------|------------|------------|
| 0     | 0     | 1          | 1          |
| 1     | 1     | 0          | 1          |
| 0     | 1     | 1          | 0          |
| 1     | 0     | 0          | 0          |

$Q_B(t+1)$

|                      |   |   |
|----------------------|---|---|
| $Q_B \backslash Q_A$ | 0 | 1 |
| 0                    | 1 | 1 |
| 1                    | 0 | 0 |

$$Q_B(t+1) = \bar{Q}_A$$

|                      |   |   |
|----------------------|---|---|
| $Q_B \backslash Q_A$ | 1 | 0 |
| 0                    | 1 | 0 |
| 1                    | 0 | 1 |

$$D_A = \bar{Q}_A \bar{Q}_B + Q_A Q_B$$

Sol. 14

Option (C) is correct.

Initially Carry Flag,  $C = 0$

```

MVI A, 07 H ; A = 0000 0111
RLC ; Rotate left without carry. A = 0000 1110
MVO B, A ; B = A = 0000 1110
RLC ; A = 0001 1100
RLC ; A = 0011 1000
ADD B ; A = 0011 1000
 +0000 1110

 0100 0110

RRC ; Rotate Right with out carry, A = 0010 0011

```

Thus  $A = 23 H$

Sol. 15

Option ( ) is correct.

$$X \text{ AND } Y = \overline{X+Y} = \bar{X}\bar{Y} \quad \equiv \quad X \text{ AND } Y = \bar{X}\bar{Y}$$

$$X \text{ OR } Y = \overline{\bar{X}\bar{Y}} = \bar{X} + \bar{Y} \quad \equiv \quad X \text{ OR } Y = \bar{X} + \bar{Y}$$

$$X \oplus Y = \bar{X}Y + X\bar{Y} \quad \equiv \quad X \oplus Y = \bar{X}Y + X\bar{Y}$$

$$X \oplus \bar{Y} = XY + \bar{X}\bar{Y} \quad \equiv \quad X \oplus \bar{Y} = XY + \bar{X}\bar{Y}$$

Sol. 16

Option (B) is correct.

Since  $\overline{G}_2$  is active low input, output of NAND gate must be 0

$$\overline{G}_2 = \overline{A_{15}} \cdot \overline{A_{14}A_{13}A_{12}A_{11}} = 0$$

So,  $A_{15}A_{14}A_{13}A_{12}A_{11} = 00101$

To select  $Y_5$  Decoder input

$$ABC = A_8A_9A_{10} = 101$$

Address range

$$A_{15}A_{14}A_{13}A_{12}A_{11}A_{10}A_9A_8 \dots A_0$$

$$\underbrace{001}_{2} \underbrace{1101}_D \dots A_0$$

$$(2D00 - 2DFF)$$

Sol. 17

Option (A) (B) (C) are correct.

In the circuit  $F = (A \oplus B) \odot (A \odot B) \odot C$

For two variables  $A \oplus B = \overline{A \odot B}$

So,  $(A \oplus B) \odot (A \odot B) = 0$  (always)

$$F = 0 \odot C = 0 \cdot C + 1 \cdot \overline{C} = \overline{C}$$

So,  $F = 1$  when  $\overline{C} = 1$  or  $C = 0$

Sol. 18

Option (D) is correct.

Let  $Q_A(n), Q_B(n), Q_C(n)$  are present states and  $Q_A(n+1), Q_B(n+1), Q_C(n+1)$  are next states of flop-flops.

In the circuit

$$Q_A(n+1) = Q_B(n) \odot Q_C(n)$$

$$Q_B(n+1) = Q_A(n)$$

$$Q_C(n+1) = Q_B(n)$$

Initially all flip-flops are reset

1<sup>st</sup> clock pulse

$$Q_A = 0 \odot 0 = 1$$

$$Q_B = 0$$

$$Q_C = 0$$

2<sup>nd</sup> clock pulse

$$Q_A = 0 \odot 0 = 1$$

$$Q_B = 1$$

$$Q_C = 0$$

3<sup>rd</sup> clock pulse

$$Q_A = 1 \odot 0 = 0$$

$$Q_B = 1$$

$$Q_C = 1$$

4<sup>th</sup> clock pulse

$$Q_A = 1 \odot 1 = 1$$

$$Q_B = 0$$

$$Q_C = 1$$

So, sequence  $Q_A = 01101 \dots$

Sol. 19

Option (D) is correct.

Output of the MUX can be written as

$$F = I_0 \bar{S}_0 \bar{S}_1 + I_1 \bar{S}_0 S_1 + I_2 S_0 \bar{S}_1 + I_3 S_0 S_1$$

Here,  $I_0 = C, I_1 = D, I_2 = \bar{C}, I_3 = \bar{C}D$

and  $S_0 = A, S_1 = B$

So, 
$$F = C \bar{A} \bar{B} + D \bar{A} B + \bar{C} A \bar{B} + \bar{C} D A B$$

Writing all SOP terms

$$F = \underbrace{\bar{A} \bar{B} C \bar{D}}_{m_1} + \underbrace{\bar{A} \bar{B} C D}_{m_2} + \underbrace{\bar{A} B C D}_{m_3} + \underbrace{\bar{A} B \bar{C} D}_{m_5} + \underbrace{A \bar{B} \bar{C} D}_{m_4} + \underbrace{A \bar{B} C \bar{D}}_{m_6} + \underbrace{A B C \bar{D}}_{m_{12}}$$

$$F = \sum m(2, 3, 5, 7, 8, 9, 12)$$

Sol. 20

Option (C) is correct.

By executing instruction one by one

MVI A, 45 H  $\Rightarrow$  MOV 45 H into accumulator,  $A = 45$  H

STC  $\Rightarrow$  Set carry,  $C = 1$

CMC  $\Rightarrow$  Complement carry flag,  $C = 0$

RAR  $\Rightarrow$  Rotate accumulator right through carry

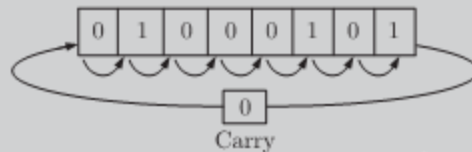

$$A = 00100010$$

XRA B  $\Rightarrow$  XOR A and B

$$A = A \oplus B = 00100010 \oplus 01000101 = 01100111 = 67_{16}$$

Sol. 21

Option (C) is correct.

TTL  $\rightarrow$  Transistor - Transistor logic

CMOS  $\rightarrow$  Complementary Metal Oxide Semi-conductor

Sol. 22

Option (D) is correct.

Vectored interrupts : Vectored interrupts are those interrupts in which program control transferred to a fixed memory location.

Maskable interrupts : Maskable interrupts are those interrupts which can be rejected or delayed by microprocessor if it is performing some critical task.

Sol. 23

Option (D) is correct.

$$\text{We have } [X + Z \{ \bar{Y} + (\bar{Z} + XY) \}] [\bar{X} + \bar{Z}(X + Y)] = 1$$

Substituting  $X = 1$  and  $\bar{X} = 0$  we get

$$[1 + Z \{ \bar{Y} + (\bar{Z} + 1\bar{Y}) \}] [0 + \bar{Z}(1 + Y)] = 1$$

$$\text{or } [1][\bar{Z}(1)] = 1$$

$$1 + A = 1 \text{ and } 0 + A = A$$

$$\text{or } \bar{Z} = 1 \leftrightarrow Z = 0$$

Sol. 24

Option (A) is correct.

The AND gate implementation by 2:1 mux is as follows

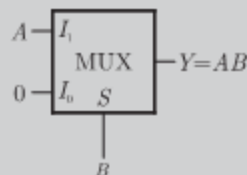

$$Y = \bar{A}I_0 + AI_1 = AB$$

The EX – OR gate implementation by 2:1 mux is as follows

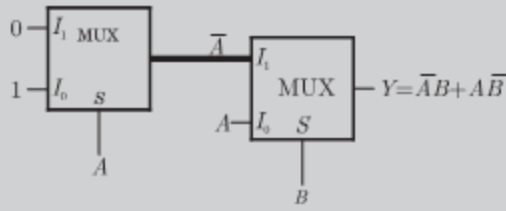

$$Y = \bar{B}I_0 + BI_1 = A\bar{B} + B\bar{A}$$

Sol. 25

Option (A) is correct.

The given circuit is as follows.

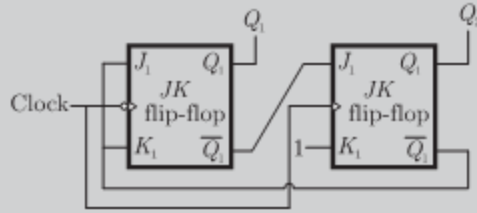

The truth table is as shown below. Sequence is 00, 11, 10, 00 ...

| CLK | $J_1$ | $K_1$ | $Q_1$ | $J_2$ | $K_2$ | $Q_2$ |
|-----|-------|-------|-------|-------|-------|-------|
| 1   | 1     | 1     | 0     | 1     | 1     | 0     |
| 2   | 1     | 1     | 1     | 1     | 1     | 1     |
| 3   | 0     | 0     | 1     | 0     | 1     | 0     |
| 4   | 1     | 1     | 0     | 1     | 1     | 0     |

Sol. 26

Option (B) is correct.

The given situation is as follows

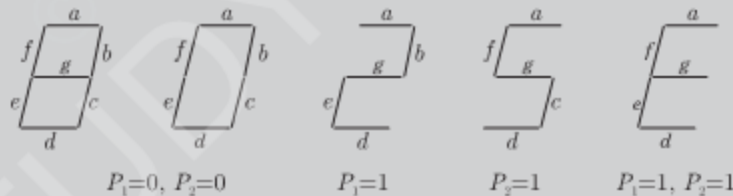

The truth table is as shown below

| $P_1$ | $P_2$ | $a$ | $b$ | $c$ | $d$ | $e$ | $f$ | $g$ |
|-------|-------|-----|-----|-----|-----|-----|-----|-----|
| 0     | 0     | 1   | 1   | 1   | 1   | 1   | 1   | 0   |
| 0     | 1     | 1   | 0   | 1   | 1   | 0   | 1   | 1   |
| 1     | 0     | 1   | 1   | 0   | 1   | 1   | 0   | 1   |
| 1     | 1     | 1   | 0   | 0   | 1   | 1   | 1   | 1   |

From truth table we can write

$$a = 1$$

$$b = \bar{P}_1\bar{P}_2 + P_1\bar{P}_2 = \bar{P}_2$$

1 NOT Gate

$$c = \bar{P}_1\bar{P}_2 + \bar{P}_1P_2 = \bar{P}_1$$

1 NOT Gate

$$d = 1 = c + e$$

|     |                                                 |           |
|-----|-------------------------------------------------|-----------|
| and | $c = \overline{P_1 P_2} = P_1 + \overline{P_2}$ | 1 OR GATE |
|     | $f = \overline{P_1 P_2} = \overline{P_1} + P_2$ | 1 OR GATE |
|     | $g = \overline{P_1 P_2} = P_1 + P_2$            | 1 OR GATE |

Thus we have  $g = P_1 + P_2$  and  $d = 1 = c + e$ . It may be observed easily from figure that

Led  $g$  does not glow only when both  $P_1$  and  $P_2$  are 0. Thus

$$g = P_1 + P_2$$

LED  $d$  is 1 all condition and also it depends on

$$d = c + e$$

Sol. 27

Option (D) is correct.

As shown in previous solution 2 NOT gates and 3-OR gates are required.

Sol. 28

Option (C) is correct.

For the NAND latch the stable states are as follows

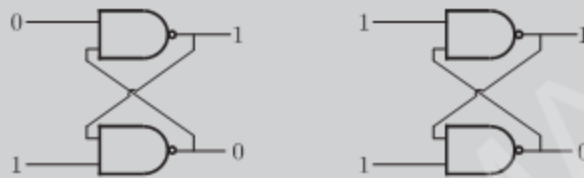

For the NOR latch the stable states are as follows



Sol. 29

Option (D) is correct.

From the figure shown below it may be easily seen upper MOSFET are shorted and connected to  $V_{dd}$  thus OUT is 1 only when the node  $S$  is 0,

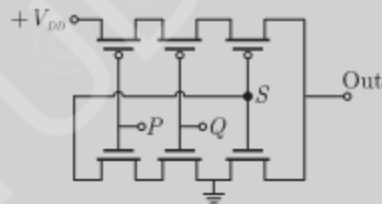

Since the lower MOSFETs are shorted to ground, node  $S$  is 0 only when input  $P$  and  $Q$  are 1. This is the function of AND gate.

Sol. 30

Option (B) is correct.

MSB of both number are 1, thus both are negative number. Now we get

$$11101101 = (-19)_{10}$$

and  $11100110 = (-26)_{10}$

$$P - Q = (-19) - (-26) = 7$$

Thus 7 signed two's complements form is

$$(7)_{10} = 00000111$$

Sol. 31

Option (D) is correct.

The circuit is as shown below

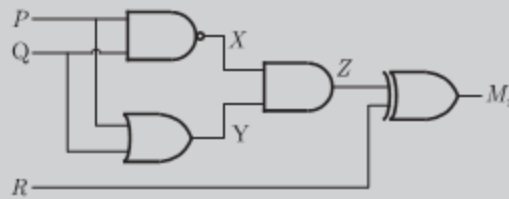

$$X = \overline{PQ}$$

$$Y = (P + Q)$$

So

$$Z = \overline{PQ}(P + Q)$$

$$= (\overline{P} + \overline{Q})(P + Q) = \overline{P}Q + P\overline{Q} = P \oplus Q$$

and

$$M_1 = Z \oplus R = (P \oplus Q) \oplus R$$

Sol. 32

Option (A) is correct.

The circuit is as shown below

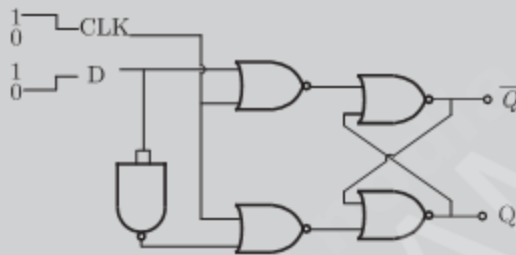

The truth table is shown below. When CLK make transition  $Q$  goes to 1 and when  $D$  goes to 1,  $Q$  goes to 0

Sol. 33

Option (B) is correct.

Since the input to both JK flip-flop is 11, the output will change every time with clock pulse. The input to clock is



The output  $Q_0$  of first FF occurs after time  $\Delta T$  and it is as shown below



The output  $Q_1$  of second FF occurs after time  $\Delta T$  when it gets input (i.e. after  $\Delta T$  from  $t_1$ ) and it is as shown below

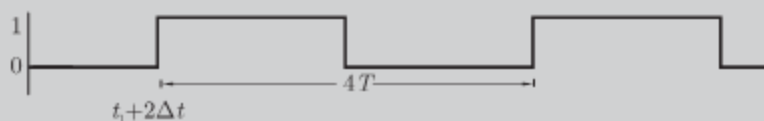

Sol. 34

Option (D) is correct.

We have

$$V_{DAC} = \sum_{n=0}^3 2^{n-1} b_n = 2^{-1} b_0 + 2^0 b_1 + 2^1 b_2 + 2^2 b_3$$

or  $V_{DAC} = 0.5b_0 + b_1 + 2b_2 + 4b_3$

The counter outputs will increase by 1 from 0000 till  $V_{ih} > V_{DAC}$ . The output of counter and  $V_{DAC}$  is as shown below

| Clock | $b_3b_2b_1b_0$ | $V_{DAC}$ |
|-------|----------------|-----------|
| 1     | 0001           | 0         |
| 2     | 0010           | 0.5       |
| 3     | 0011           | 1         |
| 4     | 0100           | 1.5       |
| 5     | 0101           | 2         |
| 6     | 0110           | 2.5       |
| 7     | 0111           | 3         |
| 8     | 1000           | 3.5       |
| 9     | 1001           | 4         |
| 10    | 1010           | 4.5       |
| 11    | 1011           | 5         |
| 12    | 1100           | 5.5       |
| 13    | 1101           | 6         |
| 14    | 1110           | 6.5       |

and when  $V_{ADC} = 6.5$  V (at 1101), the output of AND is zero and the counter stops. The stable output of LED display is 13.

Sol. 35

Option (B) is correct.

The  $V_{ADC} - V_m$  at steady state is  
 $= 6.5 - 6.2 = 0.3V$

Sol. 36

Option (A) is correct.

$$\begin{aligned} Z &= I_0 \overline{RS} + I_1 \overline{RS} + I_2 \overline{RS} + I_3 RS \\ &= (P + \overline{Q}) \overline{RS} + \overline{PRS} + PQR\overline{S} + PRS \\ &= \overline{PRS} + \overline{QRS} + \overline{PRS} + PQR\overline{S} + PRS \end{aligned}$$

The  $k$  - Map is as shown below

|      |      |    |    |    |
|------|------|----|----|----|
|      | $RS$ |    |    |    |
|      | 00   | 01 | 11 | 10 |
| $PQ$ |      |    |    |    |
| 00   | 1    |    |    |    |
| 01   |      |    |    |    |
| 11   | 1    | 1  | 1  | 1  |
| 10   | 1    | 1  | 1  |    |

$$Z = PQ + P\overline{Q}S + \overline{Q}RS$$

Sol. 37

Option (C) is correct.

2710H LXI H, 30A0H ; Load 16 bit data 30A0 in HL pair  
 2713H DAD H ; 6140H → HL

2714H PCHL ; Copy the contents 6140H of HL in PC  
 Thus after execution above instruction contents of PC and HL are same and that is 6140H

Sol. 38

Option (C) is correct.

MSB of  $Y$  is 1, thus it is negative number and  $X$  is positive number

Now we have  $X = 01110 = (14)_{10}$

and  $Y = 11001 = (-7)_{10}$

$$X + Y = (14) + (-7) = 7$$

In signed two's complements from 7 is

$$(7)_{10} = 000111$$

Sol. 39

Option (B) is correct.

$$Y = AB + CD = \overline{AB} \cdot \overline{CD}$$

This is SOP form and we require only 3 NAND gate

Sol. 40

Option (A) is correct.

The circuit is as shown below

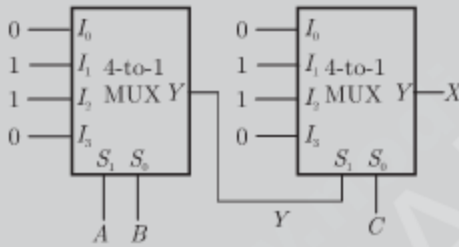

$$Y = \overline{AB} + A\overline{B}$$

and  $X = \overline{Y}C + Y\overline{C} = \overline{(\overline{AB} + A\overline{B})}C + (\overline{AB} + A\overline{B})\overline{C}$   
 $= (\overline{\overline{AB}} + \overline{A\overline{B}})C + (\overline{AB} + A\overline{B})\overline{C}$   
 $= \overline{AB} + \overline{A\overline{B}} + \overline{AB} + \overline{A\overline{B}}$   
 $= \overline{AB} + \overline{A\overline{B}}$

Sol. 41

Option (D) is correct.

$$Y = \overline{A}BC\overline{D} + \overline{A}B\overline{C}D + \overline{A}\overline{B}CD + A\overline{B}C\overline{D}$$

$$= \overline{A}BC\overline{D} + \overline{A}B\overline{C}D + \overline{A}BC\overline{D} + \overline{A}\overline{B}CD$$

$$= \overline{A}BC\overline{D} + \overline{A}B\overline{C}D + \overline{B}CD(A + \overline{A})$$

$$= \overline{A}BC\overline{D} + \overline{A}B\overline{C}D + \overline{B}CD$$

$$A + \overline{A} = 1$$

Sol. 42

Option (B) is correct.

In given TTL NOT gate when  $V_i = 2.5$  (HIGH), then

- $Q_1 \rightarrow$  Reverse active
- $Q_2 \rightarrow$  Saturation
- $Q_3 \rightarrow$  Saturation
- $Q_4 \rightarrow$  cut - off region

Sol. 43

Option (C) is correct.

For  $X = 0, Y = 1$   $P = 1, Q = 0$

For  $X = 0, Y = 0$   $P = 1, Q = 1$

For  $X = 1, Y = 1$   $P = 1, Q = 0$  or  $P = 0, Q = 1$



Sol. 44

Option (C) is correct.

Chip 8255 will be selected if bits  $A_3$  to  $A_7$  are 1. Bit  $A_0$  to  $A_2$  can be 0 or

1. Thus address range is

$$\begin{array}{r} 11111000 \quad \text{F8H} \\ 11111111 \quad \text{FFH} \end{array}$$

Sol. 45

Option (B) is correct.

Since the inverting terminal is at virtual ground the resistor network can be reduced as follows

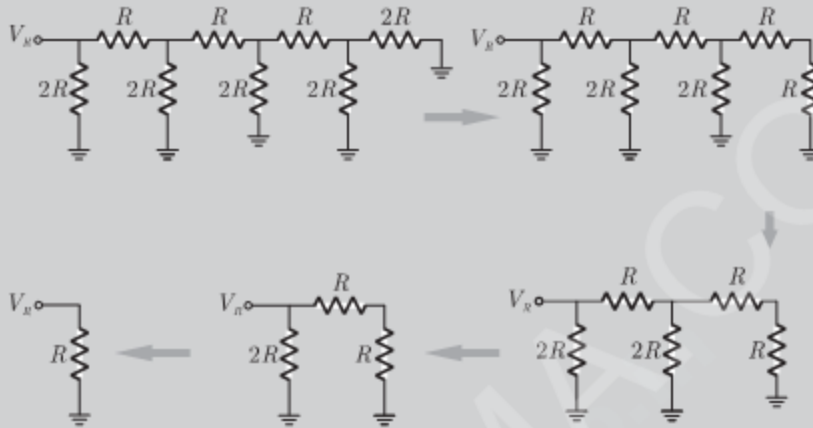

The current from voltage source is

$$I = \frac{V_s}{R} = \frac{10}{10k} = 1 \text{ mA}$$

This current will be divide as shown below

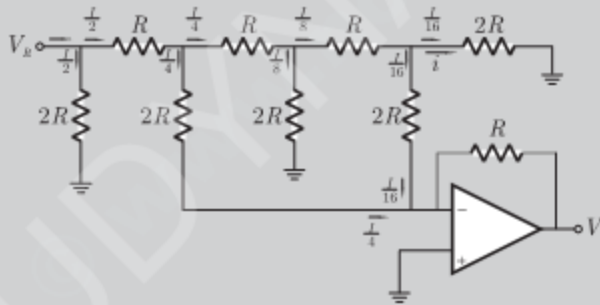

Now 
$$i = \frac{I}{16} = \frac{1 \times 10^{-3}}{16} = 62.5 \mu \text{ A}$$

Sol. 46

Option (C) is correct.

The net current in inverting terminal of OP - amp is

$$I = \frac{1}{4} + \frac{1}{16} = \frac{5I}{16}$$

So that 
$$V_0 = -R \times \frac{5I}{16} = -3.125$$

Sol. 47

Option (B) is correct.

Line

- 1 : MVI A, B5H ; Move B5H to A
- 2 : MVI B, 0EH ; Move 0EH to B
- 3 : XRI 69H ; [A] XOR 69H and store in A
- ; Contents of A is CDH

4 : ADDB ; Add the contents of A to contents of B and  
; store in A, contents of A is EAH  
5 : ANI 9BH ; [a] AND 9BH, and store in A,  
; Contents of A is 8 AH  
6 : CPI 9FH ; Compare 9FH with the contents of A  
; Since 8 AH < 9BH, CY = 1  
7 : STA 3010 H ; Store the contents of A to location 3010 H  
8 : HLT ; Stop

Thus the contents of accumulator after execution of ADD instruction is EAH.

Sol. 48

Option (C) is correct.

The  $CY = 1$  and  $Z = 0$

Sol. 49

Option (A) is correct.

For this circuit the counter state ( $Q_1, Q_0$ ) follows the sequence 00, 01, 10, 00 ... as shown below

| Clock | $D_1D_0$ | $Q_1Q_0$ | $Q_1 \text{ NOR } Q_0$ |
|-------|----------|----------|------------------------|
|       |          | 00       | 1                      |
| 1st   | 01       | 10       | 0                      |
| 2nd   | 10       | 01       | 0                      |
| 3rd   | 00       | 00       | 0                      |

|   |   |   |   |
|---|---|---|---|
| 1 | 0 | 0 | 1 |
| 0 | d | 0 | 0 |
| 0 | 0 | d | 1 |
| 1 | 0 | 0 | 1 |

Sol. 50

Option (A) is correct.

As shown below there are 2 terms in the minimized sum of product expression.

|   |   |   |   |
|---|---|---|---|
| 1 | 0 | 0 | 1 |
| 0 | d | 0 | 0 |
| 0 | 0 | d | 1 |
| 1 | 0 | 0 | 1 |

Sol. 51

Option (B) is correct.

The output is taken from the 5th line.

Sol. 52

Option (D) is correct.

After applying two clock poles, the outputs of the full adder is  $S = 1, C_0 = 1$

|     | A | B | $C_i$ | S | $C_o$ |
|-----|---|---|-------|---|-------|
| 1st | 1 | 0 | 0     | 0 | 1     |
| 2nd | 1 | 1 | 1     | 1 | 1     |

Sol. 53

Option (D) is correct.

100010011001  
4 2 3 1

Sol. 54

Option (B) is correct.

In this the diode  $D_2$  is connected to the ground. The following table shows the state of counter and D/A converter

| $Q_2Q_1Q_0$ | $D_3 = Q_2$ | $D_2 = 0$ | $D_1 = Q_1$ | $D_0 = Q_0$ | $V_o$ |
|-------------|-------------|-----------|-------------|-------------|-------|
| 000         | 0           | 0         | 0           | 0           | 0     |
| 001         | 0           | 0         | 0           | 1           | 1     |
| 010         | 0           | 0         | 1           | 0           | 2     |
| 011         | 0           | 0         | 1           | 1           | 3     |
| 100         | 1           | 0         | 0           | 0           | 8     |
| 101         | 1           | 0         | 0           | 1           | 9     |
| 110         | 1           | 0         | 1           | 0           | 10    |
| 111         | 1           | 0         | 1           | 1           | 11    |
| 000         | 0           | 0         | 0           | 0           | 0     |
| 001         | 0           | 0         | 0           | 1           | 1     |

Thus option (B) is correct

Sol. 55

Option (B) is correct.

```
LXI, EFFF H ; Load SP with data EFFFH
 CALL 3000 H ; Jump to location 3000 H
 :
 :
 :
3000H LXI H, 3CF4 ; Load HL with data 3CF4H
 PUSH PSW ; Store contents of PSW to Stack
 POP PSW ; Restore contents of PSW from stack
 PRE ; stop
```

Before instruction SPHL the contents of SP is 3CF4H.

After execution of POP PSW,  $SP + 2 \rightarrow SP$

After execution of RET,  $SP + 2 \rightarrow SP$

Thus the contents of SP will be  $3CF4H + 4 = 3CF8H$

Sol. 56

Option (A) is correct.

The inputs  $D_0$  and  $D_1$  respectively should be connected as  $\overline{Q_1}$  and  $Q_0$  where  $Q_0 \rightarrow D_1$  and  $\overline{Q_1} \rightarrow D_0$

Sol. 57

Option (D) is correct.

If the point P is stuck at 1, then output f is equal to A

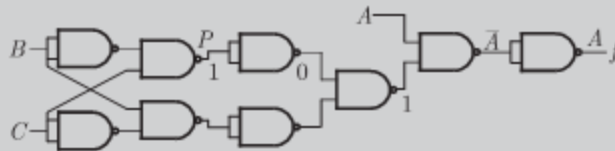

Sol. 58

Option (B) is correct.

Dividing 43 by 16 we get

$$\begin{array}{r} 2 \\ 16 \overline{)43} \\ \underline{32} \\ 11 \end{array}$$

11 in decimal is equivalent is B in hexamal.

Thus  $43_{10} \leftrightarrow 2B_{16}$

Now  $4_{10} \leftrightarrow 0100_2$

$3_{10} \leftrightarrow 0011_2$

Thus  $43_{10} \leftrightarrow 01000011_{BCD}$

Sol. 59

Option (A) is correct.

The diagram is as shown in fig

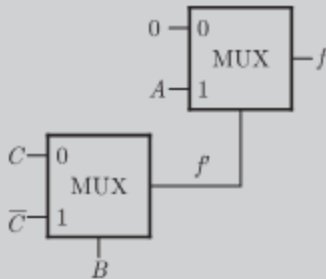

$$f = B\bar{C} + \bar{B}C$$

$$f = fA + \bar{f}0$$

$$= fA = ABC\bar{C} + A\bar{B}C$$

Sol. 60

Option (C) is correct.

The circuit is as shown below

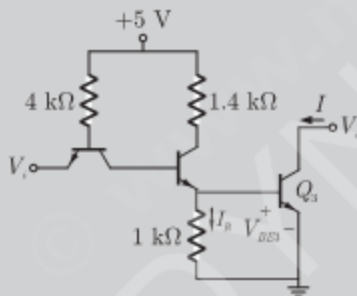

If output is at logic 0, then we have  $V_o = 0$  which signifies BJT  $Q_3$  is in saturation and applying KVL we have

$$V_{BE3} = I_R \times 1k$$

or  $0.75 = I_R \times 1k$

or  $I_R = 0.75 \text{ mA}$

Sol. 61

Option (A) is correct.

We have 
$$f = \bar{A}BC + A\bar{B}\bar{C}$$

$$= B(\bar{A}C + A\bar{C}) = B(A + C)(\bar{A} + \bar{C})$$

Sol. 62

Option (C) is correct.

Characteristic equation for a jk flip-flop is written as

$$Q_{n+1} = J\bar{Q}_n + \bar{K}Q_n$$

Where  $Q_n$  is the present output

$Q_{n+1}$  is next output

So,  $Q_{n+1} = 1\bar{0} + \bar{K} \cdot 0$

$Q_n = 0$

$Q_{n+1} = 1$

Sol. 63

Option (C) is correct.

Since  $T_2T_1T_0$  is at 111, at every clock  $Q_2Q_1Q_0$  will be changes. Ir present state is 011, the next state will be 100.

Sol. 64

Option (D) is correct.

Sol. 65

Option (C) is correct.

```

0100H LXI SP, 00FF ; Load SP with 00FFH
0103H LXI H, 0701 ; Load HL with 0107H
0106H MVI A, 20H ; Move A with 20 H
0108 H SUB M ; Subtract the contents of memory
 ; location whose address is stored in HL
 ; from the A and store in A
0109H ORI 40H ; 40H OR [A] and store in A
010BH ADD M ; Add the contents of mememory location
 ; whose address is stored in HL to A
 ; and store in A

```

HL contains 0107H and contents of 0107H is 20H

Thus after execution of SUB the data of A is  $20H - 20H = 00$

Sol. 66

Option (C) is correct.

Before ORI instruction the contents of A is 00H. On execution the ORI 40H the contents of A will be 40H

$00H = 00000000$

$40H = 01000000$

ORI 01000000

After ADD instruction the contents of memory location whose address is stored in HL will be added to and will be stored in A

$40H + 20H = 60H$

Sol. 67

Option (C) is correct.

A master slave D-flip flop is shown in the figure.

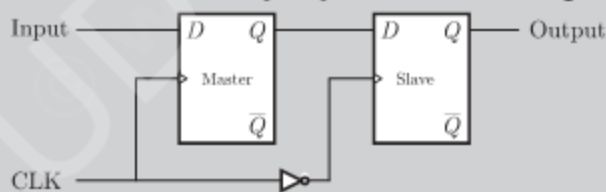

In the circuit we can see that output of flip-flop call be triggered only by transition of clock from 1 to 0 or when state of slave latch is affected.

Sol. 68

Option (A) is correct.

The range of signed decimal numbers that can be represented by  $n$  - bits 1's complement number is  $-(2^{n-1} - 1)$  to  $+(2^{n-1} - 1)$ .

Thus for  $n = 6$  we have

$$\begin{aligned} \text{Range} &= -(2^{6-1} - 1) \text{ to } +(2^{6-1} - 1) \\ &= -31 \text{ to } +31 \end{aligned}$$

Sol. 69

Option (D) is correct.

The minimum number of bit require to encode 100 increment is

$$2^n \geq 100$$

or  $n \geq 7$

Sol. 70

Option (B) is correct.

Shift Register → Serial to parallel data conversion

Counter → Frequency division

Decoder → Addressing in memory chips.

Sol. 71

Option (A) is correct.

For the TTL family if terminal is floating, then it is at logic 1.

Thus  $Y = (\overline{AB + 1}) = \overline{AB}.0 = 0$

Sol. 72

Option (C) is correct.

$$\begin{array}{r} 11001 \\ 00110 \\ +1 \\ \hline 00111 \\ 7 \end{array} \quad \begin{array}{r} 1001 \\ 0110 \\ +1 \\ \hline 0111 \\ 7 \end{array} \quad \begin{array}{r} 111001 \\ 000110 \\ +1 \\ \hline 000111 \\ 7 \end{array}$$

Thus 2's complement of 11001, 1001 and 111001 is 7. So the number given in the question are 2's complement correspond to -7.

Sol. 73

Option (C) is correct.

In the modulo - 6 ripple counter at the end of sixth pulse (i.e. after 101 or at 110) all states must be cleared. Thus when  $CB$  is 11 the all states must be cleared. The input to 2-input gate is  $\overline{C}$  and  $\overline{B}$  and the desired output should be low since the CLEAR is active low

Thus when  $\overline{C}$  and  $\overline{B}$  are 0, 0, then output must be 0. In all other case the output must be 1. OR gate can implement this functions.

Sol. 74

Option (C) is correct.

Number of MUX is  $\frac{4}{3} = 2$  and  $\frac{2}{2} = 1$ . Thus the total number 3 multiplexers is required.

Sol. 75

Option (D) is correct.

$$\begin{aligned} AC + B\overline{C} &= AC1 + B\overline{C}1 = AC(B + \overline{B}) + B\overline{C}(A + \overline{A}) \\ &= ACB + AC\overline{B} + B\overline{C}A + B\overline{C}\overline{A} \end{aligned}$$

Sol. 76

Option (D) is correct.

We have  $f(x,y) = \overline{xy} + \overline{xy} + xy = \overline{x}(\overline{y} + y) + xy = \overline{x} + xy$

or  $f(x,y) = \overline{x} + y$

Here compliments are not available, so to get  $\overline{x}$  we use NOR gate. Thus desired circuit require 1 unit OR and 1 unit NOR gate giving total cost 2 unit.

Sol. 77

Option (D) is correct.

For 8255, various modes are described as following.

Mode 1 : Input or output with hand shake

In this mode following actions are executed

1. Two port (A & B) function as 8 - bit input output ports.
2. Each port uses three lines from C as a hand shake signal
3. Input & output data are latched.

Form (ii) the mode is 1.

Mode 2 : Bi-directional data transfer

This mode is used to transfer data between two computer. In this mode port A

can be configured as bidirectional port. Port A uses five signal from port C as hand shake signal.

For (1), mode is 2

Sol. 78

Option (B) is correct.

LDA 16 bit  $\Rightarrow$  Load accumulator directly this instruction copies data byte from memory location (specified within the instruction) the accumulator.

It takes 4 memory cycle-as following.

1. in instruction fetch
2. in reading 16 bit address
1. in copying data from memory to accumulator

LXI D, (F0F1)<sub>4</sub>  $\Rightarrow$  It copies 16 bit data into register pair D and E.

It takes 3 memory cycles.

Sol. 79

Option (A) is correct.

```
LXI H, 9258H ; 9258H \rightarrow HL
MOV A, M ; (9258H) \rightarrow A
CMA ; $\bar{A} \rightarrow A$
MOV M, A ; A \rightarrow M
```

This program complement the data of memory location 9258H.

Sol. 80

Option (D) is correct.

```
MVI A, 00H ; Clear accumulator
LOOP ADD B ; Add the contents of B to A
 DCR C ; Decrement C
 JNZ LOOP ; If C is not zero jump to loop
 HLT
 END
```

This instruction set add the contents of B to accumulator to contents of C times.

Sol. 81

Option (D) is correct.

The number of distinct boolean expression of  $n$  variable is  $2^{2^n}$ . Thus

$$2^{2^4} = 2^{16} = 65536$$

Sol. 82

Option (C) is correct.

In the flash analog to digital converter, the no. of comparators is equal to  $2^{n-1}$ , where  $n$  is no. of bit.s

So,  $2^{n-1} = 2^8 - 1 = 255$

Sol. 83

Option (B) is correct.

When output of the 74 series gate of TTL gates is taken from BJT then the configuration is either totem pole or open collector configuration .

Sol. 84

Option (D) is correct.

A  $2^n:1$  MUX can implement all logic functions of  $(n + 1)$  variable without any additional circuitry. Here  $n = 3$ . Thus a 8 : 1 MUX can implement all logic functions of 4 variable.

Sol. 85

Option (D) is correct.

Counter must be reset when it count 111. This can be implemented by following circuitry





Sol. 86

Option (B) is correct.

$$\begin{aligned} \text{We have } Y &= P \oplus Q \oplus R \\ Z &= RQ + \bar{P}R + Q\bar{P} \end{aligned}$$

Here every block is a full subtractor giving  $P - Q - R$  where  $R$  is borrow. Thus circuit acts as a 4 bit subtractor giving  $P - Q$ .

Sol. 87

Option (A) is correct.

$$\begin{aligned} W &= R + \bar{P}Q + \bar{R}S \\ X &= P\bar{Q}\bar{R}S + \bar{P}Q\bar{R}S + P\bar{Q}RS \\ Y &= RS + \bar{P}R + \bar{P}Q + \bar{P}\bar{Q} = RS + \bar{P}R \cdot \bar{P}\bar{Q} \cdot \bar{P}\bar{Q} \\ &= RS + (\bar{P} + \bar{R})(\bar{P} + Q)(P + Q) \\ &= RS + (\bar{P} + \bar{P}Q + \bar{P}R + Q\bar{R})(P + Q) \\ &= RS + \bar{P}Q + Q\bar{R}(P + \bar{P}) + Q\bar{R} = RS + \bar{P}Q + Q\bar{R} \\ Z &= R + S + \bar{P}Q + \bar{P}\bar{Q}R + P\bar{Q}S = R + S + \bar{P}Q \cdot \bar{P}\bar{Q}R \cdot \bar{P}\bar{Q}S \\ &= R + S + (\bar{P} + \bar{Q})(P + Q + R)(\bar{P} + Q + S) \\ &= R + S + \bar{P}Q + \bar{P}Q + \bar{P}QS + \bar{P}R + \bar{P}QR \\ &\quad + \bar{P}RS + \bar{P}Q + P\bar{Q}S + \bar{P}\bar{Q}R + \bar{Q}RS \\ &= R + S + \bar{P}Q + \bar{P}QS + \bar{P}R + \bar{P}QR + \bar{P}RS + P\bar{Q}S + \bar{P}\bar{Q}R + \bar{Q}RS \\ &= R + S + \bar{P}Q(1 + S) + \bar{P}R(1 + \bar{P}) + \bar{P}RS + P\bar{Q}S + \bar{P}\bar{Q}R + \bar{Q}RS \\ &= R + S + \bar{P}Q + \bar{P}R + \bar{P}RS + P\bar{Q}S + \bar{P}\bar{Q}R + \bar{Q}RS \\ &= R + S + \bar{P}Q + \bar{P}R(1 + \bar{Q}) + P\bar{Q}S + \bar{Q}RS \\ &= R + S + \bar{P}Q + \bar{P}R + P\bar{Q}S + \bar{Q}RS \end{aligned}$$

Thus  $W = Z$  and  $X = \bar{Z}$

Sol. 88

Option (B) is correct.

Propagation delay of flip flop is

$$t_{pd} = 10 \text{ nsec}$$

Propagation delay of 4 bit ripple counter

$$R = 4t_{pd} = 40 \text{ ns}$$

and in synchronous counter all flip-flop are given clock simultaneously, so

$$S = t_{pd} = 10 \text{ ns}$$

Sol. 89

Option (C) is correct.

After  $t = t_1$ , at first rising edge of clock, the output of shift register is 0110, which in input to address line of ROM. At 0110 is applied to register. So at this time data stroed in ROM at 1010 (10), 1000 will be on bus.

When  $W$  has the data 0110 and it is 6 in decimal, and it's data value at that add is 1010

then 1010 i.e. 10 is acting as odd, at time  $t_2$  and data at that movement is 1000.

Sol. 90

Option (B) is correct.

The DTL has minimum fan out and CMOS has minimum power consumption. Propagation delay is minimum in ECL.



Sol. 91

Option (D) is correct.

Let input be 1010;                    output will be 1101

Let input be 0110;                    output will be 0100

Thus it convert gray to Binary code.

Sol. 92

Option (A) is correct.

CMP B     $\Rightarrow$  Compare the accumulator content with context of Register BIf  $A < R$     CY is set and zero flag will be reset.

Sol. 93

Option (A) is correct.

$$V_o = -V_1 \left[ \frac{R}{R} b_0 + \frac{R}{2R} b_1 + \frac{R}{4R} b_2 + \frac{R}{4R} b_3 \right]$$

Exact value when  $V_1 = 5$ , for maximum output

$$V_{oExact} = -5 \left[ 1 + \frac{1}{2} + \frac{1}{4} + \frac{1}{8} \right] = -9.375$$

Maximum  $V_{out}$  due to tolerance

$$V_{o\max} = -5.5 \left[ \frac{110}{90} + \frac{110}{2 \times 90} + \frac{110}{4 \times 90} + \frac{110}{8 \times 90} \right]$$

$$= -12.604$$

Tolerance                     $= 34.44\% = 35\%$ 

Sol. 94

Option (D) is correct.

If the 4-bit 2's complement representation of a decimal number is 1000, then the number is -8

Sol. 95

Option (C) is correct.

In the comparator type ADC, the no. of comparators is equal to  $2^{n-1}$ , where  $n$  is no. of bit.s

$$\text{So, } 2^3 - 1 = 7$$

Sol. 96

Option (B) is correct.

$$\text{Output of 1st XOR} = \overline{X} \cdot 1 + X \cdot \overline{1} = \overline{X}$$

$$\text{Output of 2nd XOR} = \overline{X \cdot X} + X \cdot X = 1$$

So after 4,6,8,...20 XOR output will be 1.

Sol. 97

Option (B) is correct.

They have propagation delay as respectively,

$$G_1 \rightarrow 10 \text{ nsec}$$

$$G_2 \rightarrow 20 \text{ nsec}$$

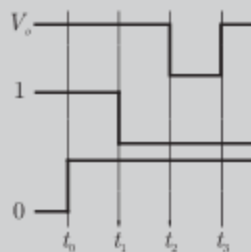
For abrupt change in  $V_i$  from 0 to 1 at time  $t = t_0$  we have to assume the output of NOR then we can say that option (B) is correct waveform.

Sol. 98

Option (B) is correct.

Let  $X_3 X_2 X_1 X_0$  be 1001 then  $Y_3 Y_2 Y_1 Y_0$  will be 1111.

Let  $X_3X_2X_1X_0$  be 1000 then  $Y_3Y_2Y_1Y_0$  will be 1110

Let  $X_3X_2X_1X_0$  be 0110 then  $Y_3Y_2Y_1Y_0$  will be 1100

So this converts 2-4-2-1 BCD numbers.

Sol. 99

Option (B) is correct.

```

MVI B, 87H ; B = 87
MOV A, B ; A = B = 87
START : JMP NEXT ; Jump to next
 XRA B ; A ⊕ B → A,
 ; A = 00, B = 87
 JP START ; Since A = 00 is positive
 ; so jump to START
 JMP NEXT ; Jump to NEXT ; unconditionally
NEXT : XRA ; B ; A ⊕ B → A, A = 87,
 ; B = 87 H
 JP START ; will not jump as D7, of A is 1
 OUT PORT2 ; A = 87 → PORT2

```

Sol. 100

Option (C) is correct.

The circuit is as shown below

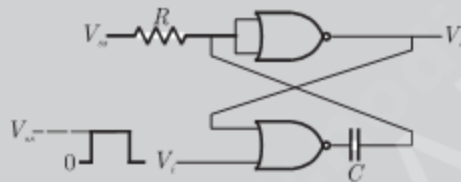

The circuit shown is monostable multivibrator as it requires an external triggering and it has one stable and one quasistable state.

Sol. 101

Option (B) is correct.

The two's complement representation of 17 is

$$17 = 010001$$

Its 1's complement is 101110

So 2's complement is

$$\begin{array}{r}
 101110 \\
 + \quad 1 \\
 \hline
 101111
 \end{array}$$

Sol. 102

Option (C) is correct.

The propagation delay of each inverter is  $t_{pd}$  then The fundamental frequency of oscillator output is

$$f = \frac{1}{2nt_{pd}} = \frac{1}{2 \times 5 \times 100 \times 10^{-12}} = 1 \text{ GHz}$$

Sol. 103

Option (C) is correct.

$4K \times 8$  bit means  $1024_{10}$  location of byte are present

Now  $1024_{10} \leftrightarrow 1000_H$

It starting address is  $AA00_H$  then address of last byte is

$$AA00_H + 1000_H - 0001_H = B9FF_H$$

Sol. 104 Option (D) is correct.

$$Y = I_0 + I_3 + I_5 + I_6 = \overline{C}BA + \overline{C}AB + C\overline{B}A + CBA$$
$$= \overline{C}(BA + AB) + C(\overline{B}A + B\overline{A})$$

or 
$$Y = \overline{C}(A \oplus B) + C(A \oplus B)$$

Sol. 105 Option (C) is correct.

The output of options (C) satisfy the given conditions

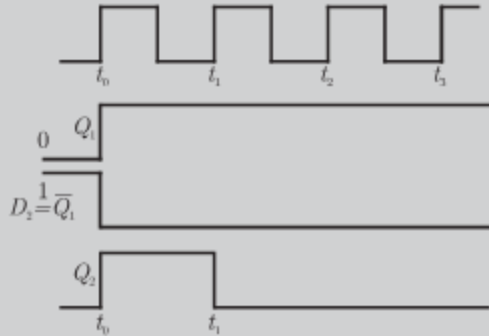

Sol. 106 Option (B) is correct.

Sol. 107 Option (D) is correct.

For the LED to glow it must be forward biased. Thus output of NAND must be LOW for LED to emit light. So both input to NAND must be HIGH. If any one or both switch are closed, output of AND will be LOW. If both switch are open, output of XOR will be LOW. So there can't be both input HIGH to NAND. So LED doesn't emit light.

Sol. 108 Option (B) is correct.

Conversion time of successive approximate analog to digital converters is independent of input voltage. It depends upon the number of bits only. Thus it remains unchanged.

Sol. 109 Option (C) is correct.

In the flash analog to digital converter, the no. of comparators is equal to  $2^{n-1}$ , where  $n$  is no. of bits.

So,  $2^4 - 1 = 15$

Sol. 110 Option (D) is correct.

As the output of AND is  $X = 1$ , the all input of this AND must be 1. Thus

$$\overline{A}B + A\overline{B} = 1 \quad \dots(1)$$

$$\overline{B}C + BC = 1 \quad \dots(2)$$

$$C = 1 \quad \dots(3)$$

From (2) and (3), if  $C = 1$ , then  $B = 1$

If  $B = 1$ , then from (1)  $A = 0$ . Thus  $A = 0, B = 1$  and  $C = 1$

Sol. 111 Option (C) is correct.

Interrupt is a process of data transfer by which an external device can inform the processor that it is ready for communication. 8085 microprocessor have five interrupts namely TRAP, INTR, RST 7.5, RST 6.5 and RST 5.5

Sol. 112

Option (A) is correct.

For any RST instruction, location of program transfer is obtained in following way.

$$\text{RST } x \Rightarrow (x * 8)_{10} \rightarrow \text{convert in hexadecimal}$$

$$\text{So for RST } 6 \Rightarrow (6 * 8)_{10} = (48)_{10} = (30)_H$$

Sol. 113

Option (A) is correct.

Accumulator contains  $A = 49 H$

Register  $B = 3 AH$

SUB  $B = A$  minus  $B$

$$A = 49 H = 01001001$$

$$B = 3 AH = 00111010$$

2's complement of  $(-B) = 11000110$

$$A - B = A + (-B)$$

$$01001001$$

$$\Rightarrow +11000110$$

$$00001111$$

$$\text{Carry} = 1$$

so here output  $A = 0 F$

$$\text{Carry } CY = 1$$

$$\text{Sign flag } S = 1$$

Sol. 114

Option (C) is correct.

The circuit is as shown below :

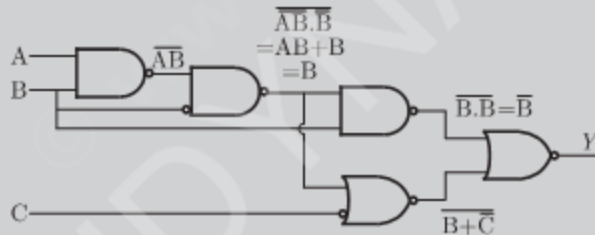

$$Y = \overline{\overline{B} + (B + \overline{C})} = B(B + \overline{C}) = B$$

Sol. 115

Option (B) is correct.

The circuit is as shown below

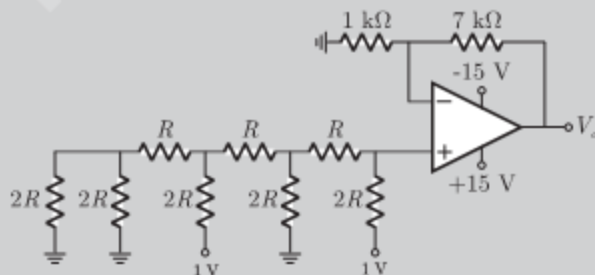

The voltage at non-inverting terminal is

$$V_+ = \frac{1}{8} + \frac{1}{2} = \frac{5}{8}$$

$$V_i = V_o = \frac{5}{8} \quad \dots(1)$$

Now applying voltage divider rule

$$V_i = \frac{1k}{1k + 7k} V_o = \frac{1}{8} V_o \quad \dots(2)$$

From (1) and (2) we have

$$V_o = 8 \times \frac{5}{8} = 5V$$

Sol. 116

Option (D) is correct.

The truth table is shown below

$$Z = \bar{X}Q + Y\bar{Q}$$

Comparing from the truth table of  $J-K$  FF

$$Y = J,$$

$$X = K$$

| $X$ | $Y$ | $Z$         |
|-----|-----|-------------|
| 0   | 0   | $\bar{Q}$   |
| 0   | 1   | 0           |
| 1   | 0   | 1           |
| 1   | 1   | $\bar{Q}_1$ |

Sol. 117

Option (B) is correct.

In the figure the given counter is mod-10 counter, so frequency of output is

$$\frac{10k}{10} = 1k$$

Sol. 118

Option (D) is correct.

We have  $y = A + \bar{A}B$

we know from Distributive property

$$x + yz = (x + y)(x + z)$$

Thus  $y = (A + \bar{A})(A + B) = A + B \quad \therefore A + \bar{A} = 1$

Sol. 119

Option (C) is correct.

Darlington emitter follower provides a low output impedance in both logical state (1 or 0). Due to this low output impedance, any stray capacitance is rapidly charged and discharged, so the output state changes quickly. It improves speed of operation.

Sol. 120

Option (D) is correct.

Sol. 121

Option (B) is correct.

For ADC we can write

$$\text{Analog input} = (\text{decimal eq of digital output}) \times \text{resol}$$

$$6.6 = (\text{decimal eq. of digital output}) \times 0.5$$

$$\frac{6.6}{0.5} = \text{decimal eq of digital. output}$$

$$13.2 = \text{decimal equivalent of digital output so output of ADC is 1101.}$$

Sol. 122

Option (A) is correct.

We use the  $K$ -map as below.

|                |      |                            |                 |      |                 |
|----------------|------|----------------------------|-----------------|------|-----------------|
|                | $BC$ | $\overline{B}\overline{C}$ | $\overline{B}C$ | $BC$ | $B\overline{C}$ |
| $\overline{A}$ | 1    |                            | 1               | 1    |                 |
| $A$            |      |                            |                 | 1    |                 |

So given expression equal to

$$= \overline{A}\overline{C} + B\overline{C} + \overline{A}B$$

Sol. 123

Option (C) is correct.

For a binary half-subtractor truth table is given below.

| $A$ | $B$ | $D = A \text{ minus } B$ | Borrow ( $X$ ) |
|-----|-----|--------------------------|----------------|
| 0   | 0   | 0                        | 0              |
| 0   | 1   | 1                        | 1              |
| 1   | 0   | 1                        | 0              |
| 1   | 1   | 0                        | 0              |

from truth table we can find expressions of  $D$  &  $X$

$$D = A \oplus B = \overline{A}B + A\overline{B}$$

$$X = \overline{A}B$$

Sol. 124

Option (B) is correct.

We have 4 K RAM (12 address lines)

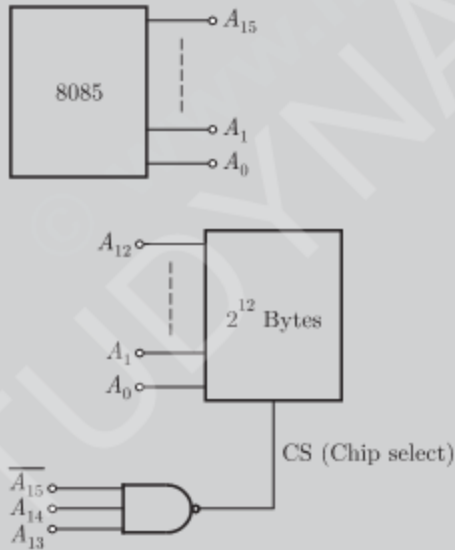

So here chip select logic  $CS = A_{15}A_{14}A_{13}$

address range (111)

|                 |                              |          |          |          |          |          |       |       |       |       |       |       |       |       |       |       |
|-----------------|------------------------------|----------|----------|----------|----------|----------|-------|-------|-------|-------|-------|-------|-------|-------|-------|-------|
|                 | $A_{15}$                     | $A_{14}$ | $A_{13}$ | $A_{12}$ | $A_{11}$ | $A_{10}$ | $A_9$ | $A_8$ | $A_7$ | $A_6$ | $A_5$ | $A_4$ | $A_3$ | $A_2$ | $A_1$ | $A_0$ |
| initial address | 1                            | 1        | 1        | 0        | 0        | 0        | 0     | 0     | 0     | 0     | 0     | 0     | 0     | 0     | 0     | 0     |
|                 | $\Rightarrow 7000 \text{ H}$ |          |          |          |          |          |       |       |       |       |       |       |       |       |       |       |
| final address   | 1                            | 1        | 1        | 1        | 1        | 1        | 1     | 1     | 1     | 1     | 1     | 1     | 1     | 1     | 1     | 1     |
|                 | $\Rightarrow 7FFF \text{ H}$ |          |          |          |          |          |       |       |       |       |       |       |       |       |       |       |

so address range is (7000 H – 7FFF H)

Sol. 125

Option (D) is correct.

From the given figure we can write the output

| $Q_A$ | $Q_B$ | $Q_C$ |
|-------|-------|-------|
| 1     | 1     | 1     |
| 0     | 1     | 1     |
| 1     | 0     | 1     |
| 0     | 0     | 1     |
| 1     | 1     | 0     |
| 0     | 1     | 0     |

For the state 010 all preset = 1 and output  $Q_A Q_B Q_C = 111$  so here total no. of states = 5 (down counter)

Sol. 126

Option (C) is correct.

Given boolean function is

$$Z = A\bar{B}C$$

Now

$$\bar{Z} = \overline{A\bar{B}C} = \overline{AC\bar{B}} = \overline{AC} + B$$

Thus

$$Z = \overline{\overline{AC} + B}$$

we have

$$Z = \overline{X + Y} \text{ (1 NOR gate)}$$

where

$$X = \overline{AC} \text{ (1 NAND gate)}$$

To implement a NOR gate we required 4 NAND gates as shown below in figure.



here total no. of NAND gates required

$$= 4 + 1 = 5$$

Sol. 127

Option (B) is correct.

For TTL worst cases low voltages are

$$V_{OL}(\max) = 0.4 \text{ V}$$

$$V_{IL}(\max) = 0.8 \text{ V}$$

Worst case high voltages are

$$V_{OH}(\min) = 2.4 \text{ V}$$

$$V_{IH}(\min) = 2 \text{ V}$$

The difference between maximum input low voltage and maximum output low voltage is called noise margin. It is 0.4 V in case of TTL.

Sol. 128

Option (D) is correct.

From the figure we can see

If  $A = 1 \quad B = 0$

then  $y = 1 \quad x = 0$

If  $A = 1 \quad B = 1$

then also  $y = 1 \quad x = 0$

so for sequence  $B = 101010\dots$  output  $x$  and  $y$  will be fixed at 0 and 1 respectively.

Sol. 129

Option (D) is correct.

Given 2's complement no. 1101; the no. is 0011  
for 6 digit output we can write the no. is - 000011  
2's complement representation of above no. is 111101

Sol. 130

Option (A) is correct.

Sol. 131

Option (B) is correct.

An *I/O* Microprocessor controls data flow between main memory and the *I/O* device which wants to communicate.

Sol. 132

Option (D) is correct.

Sol. 133

Option (B) is correct.

Dual slope ADC is more accurate.

Sol. 134

Option (A) is correct.

Dual form of any identity can be find by replacing all AND function to OR and vice-versa. so here dual form will be

$$(A + B)(\bar{A} + C)(B + C) = (A + B)(\bar{A} + C)$$

Sol. 135

Option (B) is correct.

Carry flag will be affected by arithmetic instructions only.

Sol. 136

Option (C) is correct.

This is a synchronous counter. we can find output as

| $Q_A$    | $Q_B$ |
|----------|-------|
| 0        | 0     |
| 1        | 0     |
| 0        | 1     |
| 0        | 0     |
| $\vdots$ |       |

So It counts only three states. It is a mod-3 counter.

$$K = 3$$

Sol. 137

Option (B) is correct.

Sol. 138

Option (A) is correct.

Essential prime implicates for a function is no. of terms that we get by solving  $K$ -map. Here we get 4 terms when solve the  $K$ -map.

|      |      |    |    |    |    |
|------|------|----|----|----|----|
|      | $AB$ | 00 | 01 | 11 | 10 |
| $CD$ | 00   | 1  | 1  |    | 1  |
| 01   |      |    |    |    | 1  |
| 11   |      | 1  |    |    |    |
| 10   |      | 1  |    |    | 1  |

$$y = \bar{B} \bar{D} + \bar{A} \bar{C} \bar{D} + \bar{C} \bar{A} \bar{B} + \bar{C} \bar{A} \bar{B}$$

so no of prime implicates is 4



Sol. 139 Option (A) is correct.

Sol. 140 Option (B) is correct.  
For a 2 bit multiplier

$$\begin{array}{r} B_1 \quad B_0 \\ \times A_1 \quad A_0 \\ \hline A_0 B_1 \quad A_0 B_0 \\ \times A_1 B_1 \quad A_1 B_0 \\ \hline C_3 \quad C_2 \quad C_1 \quad C_0 \end{array}$$

This multiplication is identical to AND operation and then addition.

Sol. 141 Option (C) is correct.

In totem pole stage output resistance will be small so it acts like a output buffer.

Sol. 142 Option (B) is correct.

Consider high output state

$$\text{fan out} = \frac{I_{OH \max}}{I_{IH \max}} = \frac{400 \text{ mA}}{20 \text{ mA}} = 20$$

Consider low output state

$$\text{fan out} = \frac{I_{OL \max}}{I_{IL \max}} = \frac{8 \text{ mA}}{0.1 \text{ mA}} = 80$$

Thus fan out is 20

Sol. 143 Option (A) is correct.

The given gate is ex-OR so output

$$F = A\bar{B} + \bar{A}B$$

Here input

$$B = 0 \text{ so,}$$

$$F = A1 + \bar{A}0 = A$$

Sol. 144 Option (C) is correct.

$EI$  = Enabled Interput flag, RST will cause an Interrupt only if we enable  $EI$ .

Sol. 145 Option (A) is correct.

Here only for the range 60 to 63 H  $\overline{\text{chipselect}}$  will be 0, so peripheral will correspond in this range only  $\text{chipselect} = 1$  for rest of the given address ranges.

Sol. 146 Option (B) is correct.

By executing instructions one by one

LXI H, 8A79 H (Load HL pair by value 8A79)

$$H = 8AH \quad L = 79H$$

MOV A, L (copy contain of L to accumulator)

$$A = 79H$$

ADDH (add contain of H to accumulator)

$$A = 79H = \quad 01111001$$

$$H = 8AH = \text{add } 10001010 = A = \quad 00000011$$

Carry = 1

DAA (Carry Flag is set, so DAA adds 6 to high order four bits)

$$01111001$$

$$\text{DAA add } 10001010$$

$A = 00000011 = 63 \text{ H}$   
 MOV H, A (copy contain of A to H)  
 $H = 63 \text{ H}$   
 PCHL (Load program counter by HL pair)  
 $PC = 6379 \text{ H}$

Sol. 147 Option (C) is correct.

Sol. 148 Option (C) is correct.

NMOS In parallel makes OR Gate & in series makes AND so here we can have

$$F = \overline{A(B+C) + DE}$$

we took complement because there is another NMOS given above (works as an inverter)

Sol. 149 Option (D) is correct.

For a J-K flip flop we have characteristic equation as

$$Q(t+1) = J\overline{Q}(t) + \overline{K}Q(t)$$

$Q(t)$  &  $Q(t+1)$  are present & next states.

In given figure  $J = \overline{Q}(t)$ ,  $K = 1$  so

$$Q(t+1) = \overline{Q}(t)\overline{Q}(t) + 0Q(t)$$

$$Q(t+1) = \overline{Q}(t)[\text{complement of previous state}]$$

we have initial input  $Q(t) = 0$

so for 6 clock pulses sequence at output  $Q$  will be 010101

Sol. 150 Option (C) is correct.

Sol. 151 Option (B) is correct.

By distributive property in boolean algebra we have

$$(A + BC) = (A + B)(A + C)$$

$$(A + B)(A + C) = AA + AC + AB + BC$$

$$= A(1 + C) + AB + BC = A + AB + BC$$

$$= A(1 + B) + BC = A + BC$$

Sol. 152 Option (A) is correct.

The current in a p n junction diode is controlled by diffusion of majority carriers while current in schottky diode dominated by the flow of majority carrier over the potential barrier at metallurgical junction. So there is no minority carrier storage in schottky diode, so switching time from forward bias to reverse bias is very short compared to p n junction diode. Hence the propagation delay will reduces.

Sol. 153 Option (B) is correct.

Sol. 154 Option (D) is correct.

The total conversion time for different type of ADC are given as-

$\tau$  is clock period

For flash type  $\Rightarrow 1\tau$

Counter type  $\Rightarrow (2^n - \tau) = 4095 \mu\text{sec}$

$n = \text{no. of bits}$

Integrating type conver time  $> 4095 \mu\text{sec}$

successive approximation type  $n\tau = 12 \mu\text{sec}$

here  $n = 12$  so

$$n\tau = 12$$

$$12\tau = 12$$

so this is succ. app. type ADC.

Sol. 155

Option (D) is correct.

LDA 2003 (Load accumulator by a value 2003 H) so here total no. of memory access will be 4.

1 = Fetching instruction

2 = Read the value from memory

1 = write value to accumulator

Sol. 156

Option (D) is correct.

Storage capacitance

$$C = \frac{i}{\left(\frac{dv}{dt}\right)} = \frac{1 \times 10^{-12}}{\left(\frac{5 - 0.5}{20 \times 10^{-3}}\right)}$$
$$= \frac{1 \times 10^{-12} \times 20 \times 10^{-3}}{4.5} = 4.4 \times 10^{-15} \text{ F}$$

Sol. 157

Option (A) is correct.

$$\text{Accuracy} \pm \frac{1}{2} \text{LSB} = T_{\text{coff}} \times \Delta T$$

or 
$$\frac{1}{2} \times \frac{10.24}{2^{10}} = T_{\text{coff}} \times \Delta T$$

or 
$$T_{\text{coff}} = \frac{10.24}{2 \times 1024 \times (50 - 25)} \text{ }^\circ\text{C} = 200 \mu\text{V/ }^\circ\text{C}$$

Sol. 158

Option (D) is correct.

$$\text{No. of chips} = \frac{26 \times 2^{10} \times 8}{2^{12} \times 4} = 13$$

Sol. 159

Option (C) is correct.

Given instruction set

1000 LXI SP 27FF

1003 CALL 1006

1006 POP H

First Instruction will initialize the SP by a value

$$27\text{FF} \quad \text{SP} \leftarrow 27\text{FF}$$

CALL 1006 will "Push PC" and Load PC by value 1006

PUSH PC will store value of PC in stack

$$\text{PC} = 1006$$

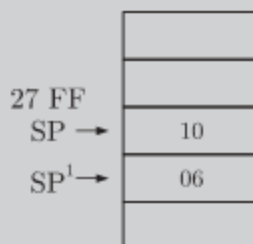

now POP H will be executed

which load HL pair by stack values

$$HL = 1006 \quad \text{and}$$

$$SP = SP' + 2$$

$$SP = SP' + 2 = SP - 2 + 2 = SP$$

$$SP = 27FF$$

\*\*\*\*\*

© www.nodia.co.in  
STUDYNAMA.COM