



SNS COLLEGE OF TECHNOLOGY

An Autonomous Institution Coimbatore – 35

Accredited by NBA – AICTE and Accredited by NACC – UGC with 'A++ Grade
Approved by AICTE , New Delhi and Affiliated to Anna University , Chennai.

DEPARTMENT OF AGRICULTURAL ENGINEERING

19AGB401- Solar and Wind Energy





Wind Generation

History of Wind-Mills:

- The wind is a by-product of solar energy. Approximately 2% of the sun's energy reaching the earth is converted into wind energy.
- The surface of the earth heats and cools unevenly, creating atmospheric pressure zones that make air flow from high- to low-pressure areas.
- The wind has played an important role in the history of human civilization .
- The first known use of wind dates back 5,000 years to Egypt, where boats used sails to travel from shore to shore.



Wind Generation-1

- The first true windmill, a machine with vanes attached to an axis to produce circular motion, may have been built as early as 2000 B.C.
- In ancient Babylon. By the 10th century A.D., windmills with wind-catching surfaces having 16 feet length and 30 feet height were grinding grain in the areas in eastern Iran and Afghanistan.
- The earliest written references to working wind machines in western world date from the 12th century.
- These too were used for milling grain. It was not until a few hundred years later that windmills were modified to pump water and reclaim much of Holland from the sea.



Wind Generation-2



- The multi-vane "farm windmill" of the American Midwest and West was invented in the United States during the latter half of the 19th century.
- In 1889 there were 77 windmill factories in the United States, and by the turn of the century, windmills had become a major American export.
- Until the diesel engine came along, many transcontinental rail routes in the U.S. depended on large multi-vane windmills to pump water for steam locomotives.
- Farm windmills are still being produced and used, though in reduced numbers.
- They are best suited for pumping ground water in small quantities to



Wind Generation-3



- In the 1930s and 1940s, hundreds of thousands of electricity producing wind turbines were built in the U.S.
- They had two or three thin blades which rotated at high speeds to drive electrical generators.
- These wind turbines provided electricity to farms beyond the reach of power lines and were typically used to charge storage batteries, operate radio receivers and power a light bulb.
- By the early 1950s, however, the extension of the central power grid to nearly every American household, via the Rural Electrification Administration, eliminated the market for these machines. Wind turbine development lay nearly dormant for the next 20 years.



Wind Generation-3

- A typical modern windmill looks as shown in the following figure.
- The wind-mill contains three blades about a horizontal axis installed on a tower.
- A turbine connected to a generator is fixed about the horizontal axis.

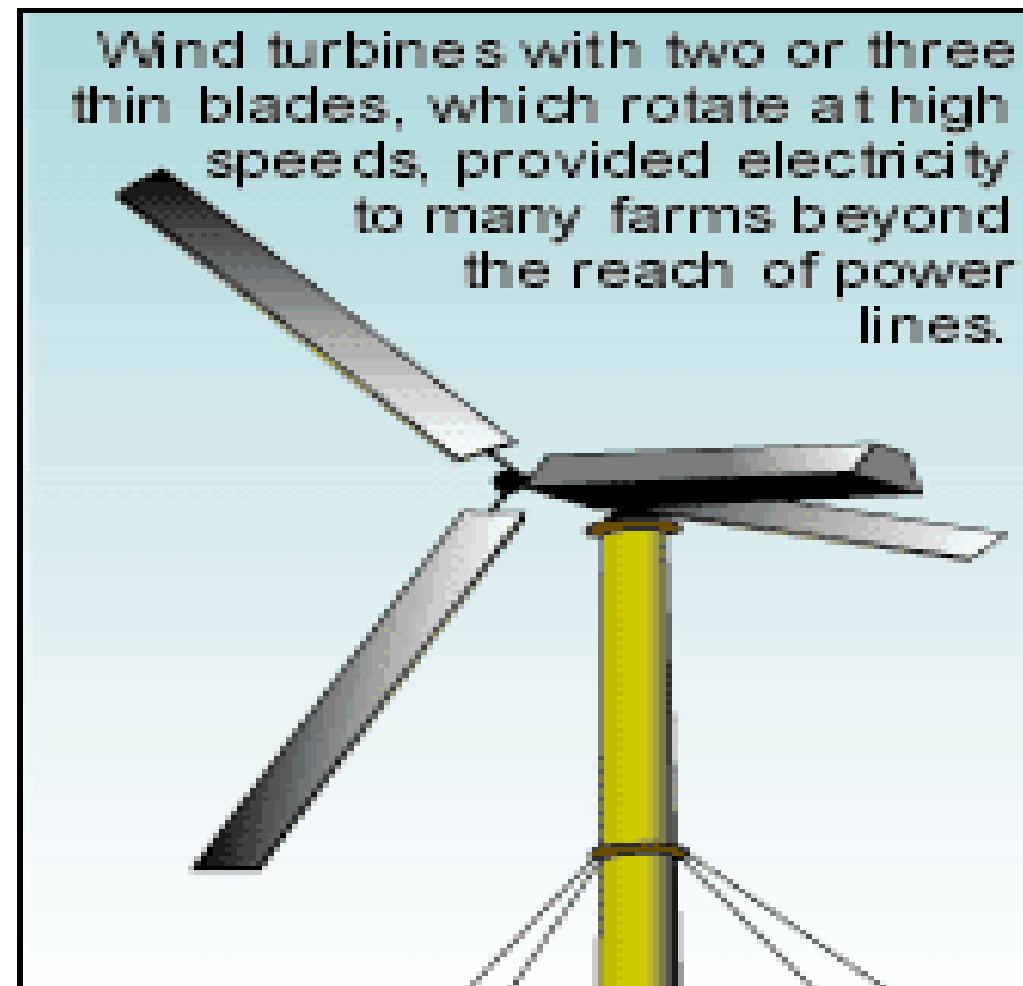



Wind Generation-4



- Like the weather in general, the wind can be unpredictable. It varies from place to place, and from moment to moment.
- Because it is invisible, it is not easily measured without special instruments.
- Wind velocity is affected by the trees, buildings, hills and valleys around us.
- Wind is a diffuse energy source that cannot be contained or stored for use elsewhere or at another time.



Classification of Wind-mills



- Wind turbines are classified into two general types: Horizontal axis and Vertical axis.
- A horizontal axis machine has its blades rotating on an axis parallel to the ground as shown in the above figure.
- A vertical axis machine has its blades rotating on an axis perpendicular to the ground.
- There are a number of available designs for both and each type has certain advantages and disadvantages.
- However, compared with the horizontal axis type, very few vertical axis machines are available commercially.



Classification of Wind-mills-1



Horizontal Axis:

- This is the most common wind turbine design.
- In addition to being parallel to the ground, the axis of blade rotation is parallel to the wind flow.
- Some machines are designed to operate in an upwind mode, with the blades upwind of the tower.
- In this case, a tail vane is usually used to keep the blades facing into the wind.
- Other designs operate in a downwind mode so that the wind passes the tower before striking the blades.
- Some very large wind turbines use a motor-driven mechanism that turns the machine in response to a wind direction sensor mounted on the tower.



Classification of Wind-mills-3



Vertical Axis:

- Although vertical axis wind turbines have existed for centuries, they are not as common as their horizontal counterparts.
- The main reason for this is that they do not take advantage of the higher wind speeds at higher elevations above the ground as well as horizontal axis turbines.
- The basic vertical axis designs are the Darrieus, which has curved blades and efficiency of 35%, the Giromill, which has straight blades, and efficiency of 35%, and the Savonius, which uses scoops to catch the wind and the efficiency of 30%.
- A vertical axis machine need not be oriented with respect to wind



Classification of Wind-mills-4

- Because the shaft is vertical, the transmission and generator can be mounted at ground level allowing easier servicing and a lighter weight, lower cost tower.
- Although vertical axis wind turbines have these advantages, their designs are not as efficient at collecting energy from the wind as are the horizontal machine designs.
- There is one more type of wind-mill called Cyclo-gyro wind-mill with very high efficiency of about 60%. However, it is not very stable and is very sensitive to wind direction. It is also very complex to build.



Classification of Wind-mills-5



- The following figures show all the above mentioned mills.

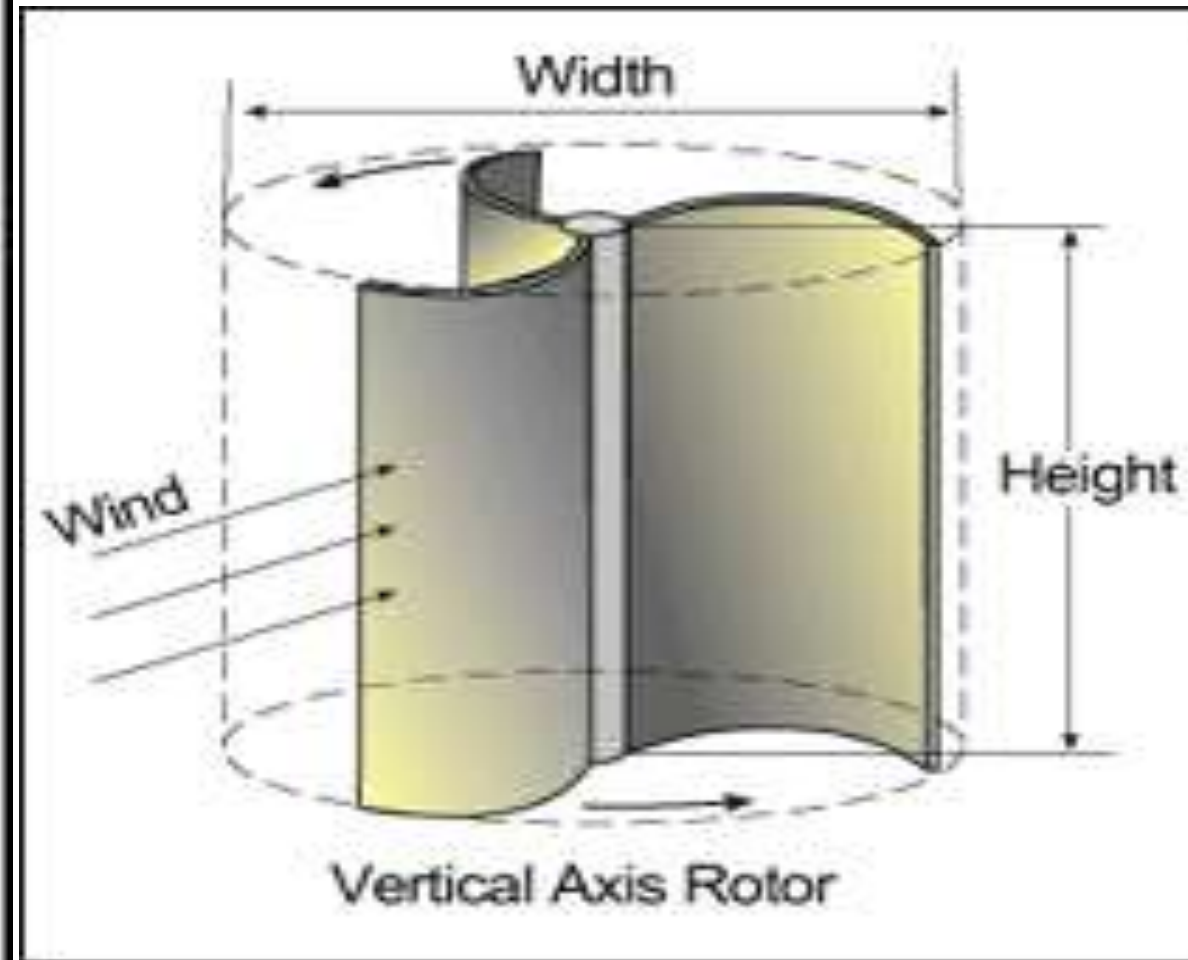
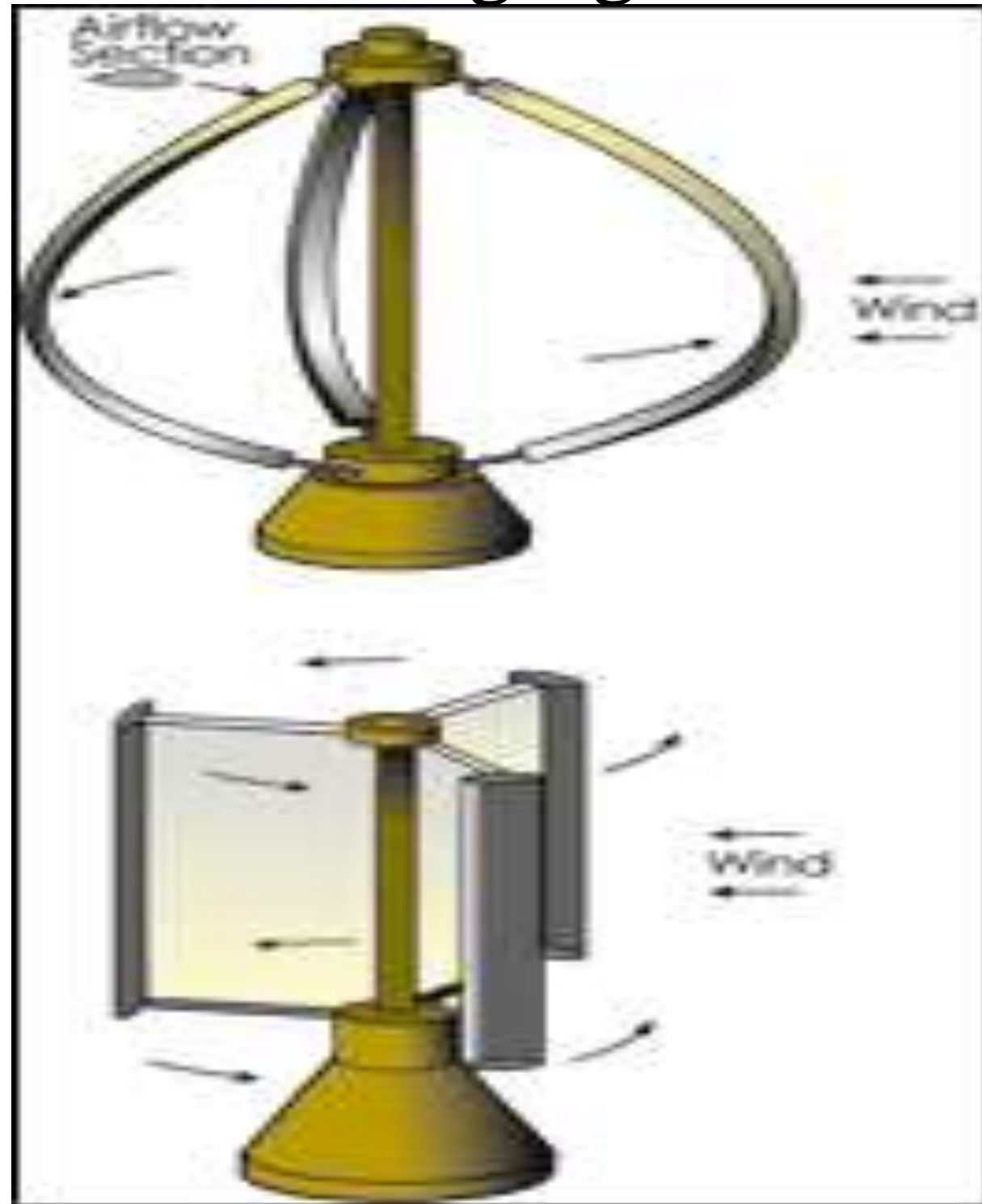



Main Components of a wind-mill

- Following figure shows typical components of a horizontal axis wind mill.

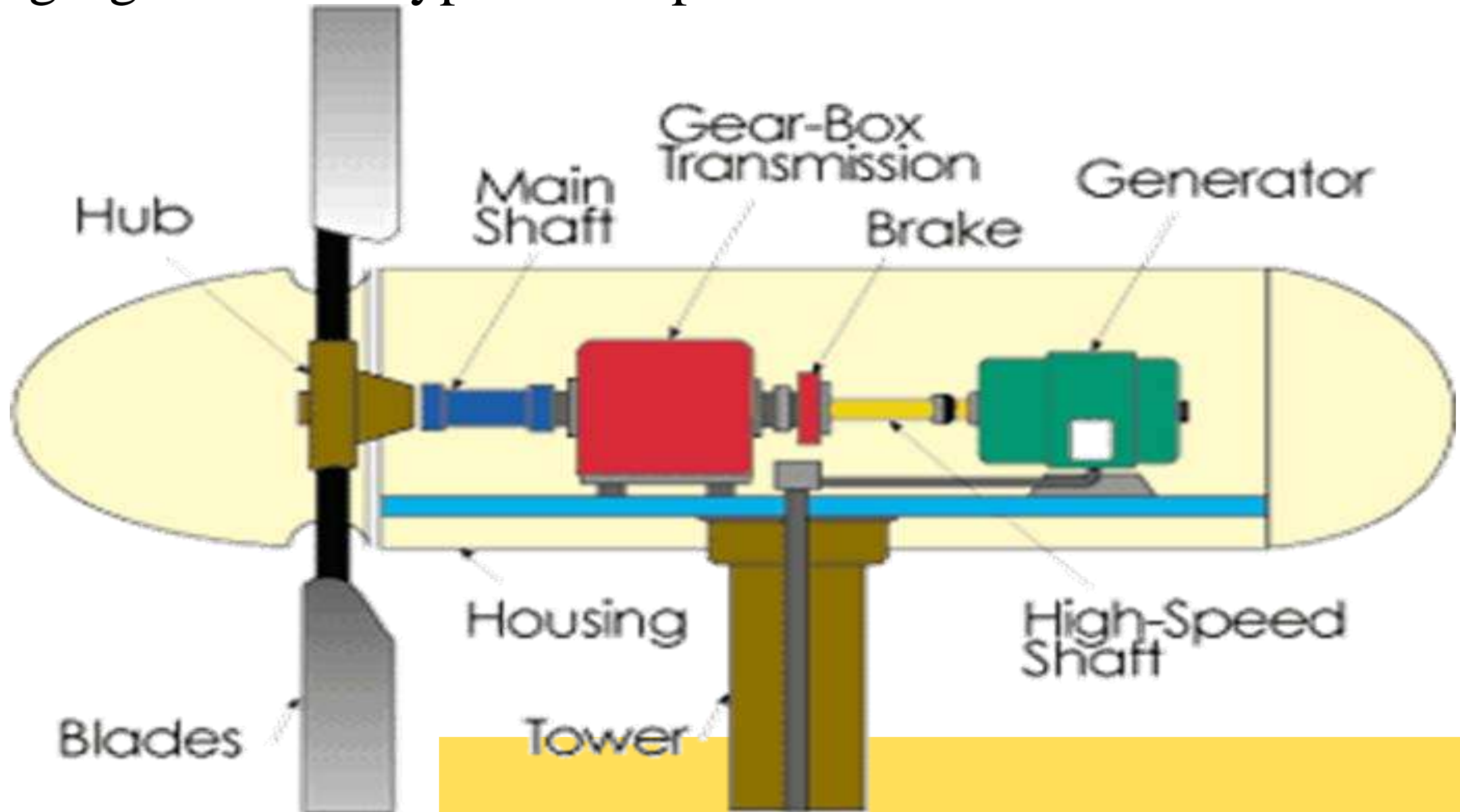



Main Components of a wind-mill-1



Rotor:

- The portion of the wind turbine that collects energy from the wind is called the rotor.
- The rotor usually consists of two or more wooden, fiberglass or metal blades which rotate about an axis (horizontal or vertical) at a rate determined by the wind speed and the shape of the blades.
- The blades are attached to the hub, which in turn is attached to the main shaft.

Drag Design:

- Blade designs operate on either the principle of drag or lift.
- For the drag design, the wind literally pushes the blades out of the way.
- Drag powered wind turbines are characterized by slower rotational



Main Components of a wind-mill-2



Lift Design:

- The lift blade design employs the same principle that enables airplanes, kites and birds to fly.
- The blade is essentially an airfoil, or wing.
- When air flows past the blade, a wind speed and pressure differential is created between the upper and lower blade surfaces.
- The pressure at the lower surface is greater and thus acts to "lift" the blade.
- When blades are attached to a central axis, like a wind turbine rotor, the lift is translated into rotational motion.
- Lift-powered wind turbines have much higher rotational speeds than drag types and therefore well suited for electricity generation.



Main Components of a wind-mill-3



- Following figure gives an idea about the drag and lift principle.

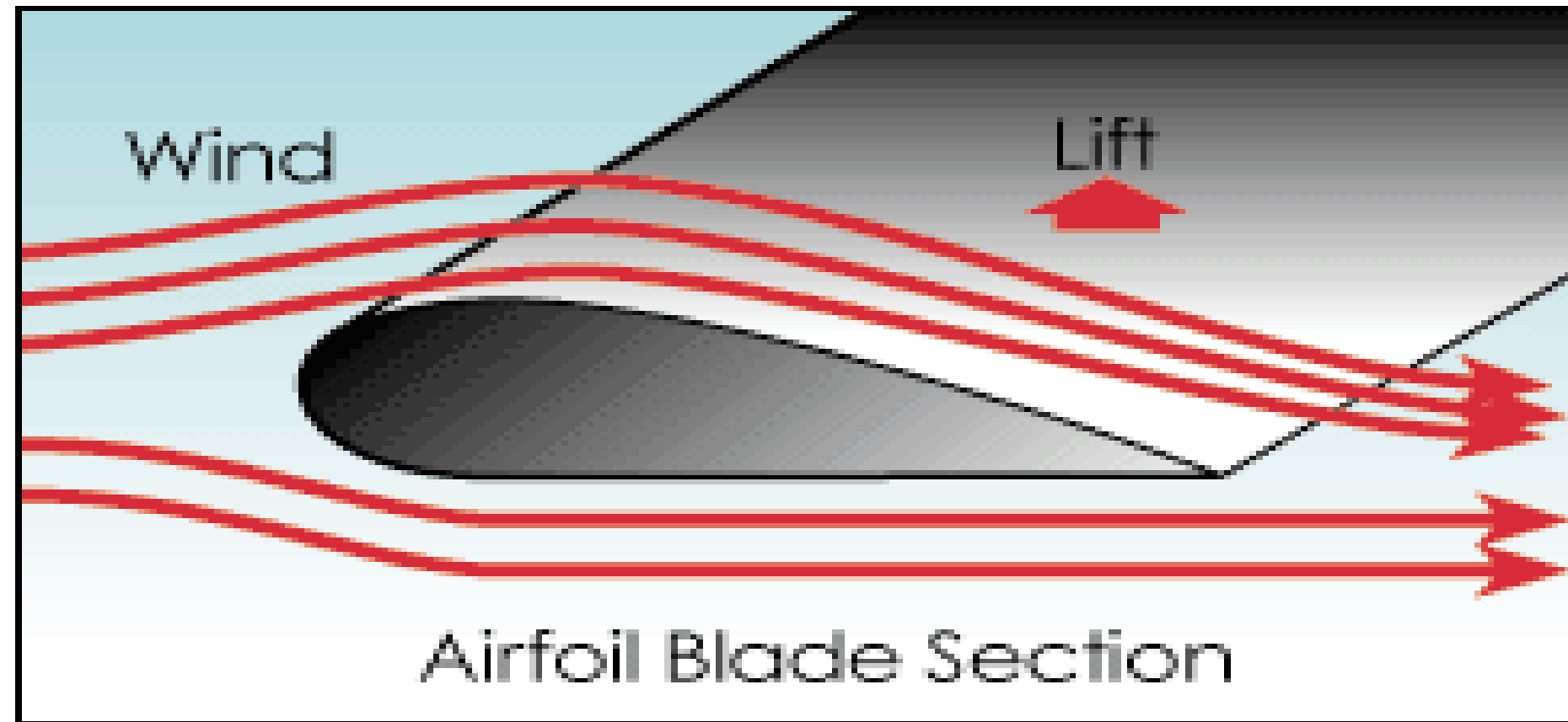

- **Tip Speed Ratio:**

- The tip-speed is the ratio of the rotational speed of the blade to the wind speed.
- The larger this ratio, the faster the rotation of the wind turbine rotor at a given wind speed.



Main Components of a wind-mill-4



- Electricity generation requires high rotational speeds.
- Lift-type wind turbines have maximum tip-speed ratios of around 10, while drag-type ratios are approximately 1.
- Given the high rotational speed requirements of electrical generators, it is clear that the lift-type wind turbine is most practical for this application.
- The number of blades that make up a rotor and the total area they cover affect wind turbine performance.
- For a lift-type rotor to function effectively, the wind must flow smoothly over the blades.
- To avoid turbulence, spacing between blades should be great enough so that one blade will not encounter the disturbed, weaker air flow caused by the blade which passed before it.



Main Components of a wind-mill-5



Generator:

- The generator is what converts the turning motion of a wind turbine's blades into electricity.
- Inside this component, coils of wire are rotated in a magnetic field to produce electricity.
- Different generator designs produce either alternating current (AC) or direct current (DC), and they are available in a large range of output power ratings.
- The generator's rating, or size, is dependent on the length of the wind turbine's blades because more energy is captured by longer blades.
- It is important to select the right type of generator to match intended use.



Main Components of a wind-mill-6



- Most home and office appliances operate on 240 volt, 50 cycles AC.
- Some appliances can operate on either AC or DC, such as light bulbs and resistance heaters, and many others can be adapted to run on DC.
- Storage systems using batteries store DC and usually are configured at voltages of between 12 volts and 120 volts.
- Generators that produce AC are generally equipped with features to produce the correct voltage of 240 V and constant frequency 50 cycles of electricity, even when the wind speed is fluctuating.
- DC generators are normally used in battery charging applications and for operating DC appliances and machinery.
- They also can be used to produce AC electricity with the use of an inverter, which converts DC to AC.



Main Components of a wind-mill-7



Transmission:

- The number of revolutions per minute (rpm) of a wind turbine rotor can range between 40 rpm and 400 rpm, depending on the model and the wind speed.
- Generators typically require rpm's of 1,200 to 1,800.
- As a result, most wind turbines require a gear-box transmission to increase the rotation of the generator to the speeds necessary for efficient electricity production.
- Some DC-type wind turbines do not use transmissions.
- Instead, they have a direct link between the rotor and generator.
- These are known as direct drive systems.
- Without a transmission, wind turbine complexity and maintenance requirements are reduced.



Main Components of a wind-mill-8



Tower:

- The tower on which a wind turbine is mounted is not just a support structure.
- It also raises the wind turbine so that its blades safely clear the ground and so it can reach the stronger winds at higher elevations.
- Maximum tower height is optional in most cases, except where zoning restrictions apply.
- The decision of what height tower to use will be based on the cost of taller towers versus the value of the increase in energy production resulting from their use.
- Studies have shown that the added cost of increasing tower height is often justified by the added power generated from the stronger winds.
- Larger wind turbines are usually mounted on towers ranging from 40 to 70 meters tall.



Main Components of a wind-mill-9



- Towers for small wind systems are generally "guyed" designs.
- This means that there are guy wires anchored to the ground on three or four sides of the tower to hold it erect.
- These towers cost less than freestanding towers, but require more land area to anchor the guy wires.
- Some of these guyed towers are erected by tilting them up.
- This operation can be quickly accomplished using only a winch, with the turbine already mounted to the tower top.
- This simplifies not only installation, but maintenance as well. Towers can be constructed of a simple tube, a wooden pole or a lattice of tubes, rods, and angle iron.

➤ Large wind turbines may be mounted on lattice towers, tube towers or



Operating Characteristics of wind mills



- All wind machines share certain operating characteristics, such as cut-in, rated and cut-out wind speeds.

Cut-in Speed:

- Cut-in speed is the minimum wind speed at which the blades will turn and generate usable power.
- This wind speed is typically between 10 and 16 kmph.

Rated Speed:

- The rated speed is the minimum wind speed at which the wind turbine will generate its designated rated power.

For example, a "10 kilowatt" wind turbine may not generate 10 kilowatts until wind speeds reach 40 kmph.

- Rated speed for most machines is in the range of 40 to 55 kmph.



Operating Characteristics of wind mills-1



- At wind speeds between cut-in and rated, the power output from a wind turbine increases as the wind increases.
- The output of most machines levels off above the rated speed. Most manufacturers provide graphs, called "power curves," showing how their wind turbine output varies with wind speed.

Cut-out Speed:

- At very high wind speeds, typically between 72 and 128 kmph, most wind turbines cease power generation and shut down.
- The wind speed at which shut down occurs is called the cut-out speed.
- Having a cut-out speed is a safety feature which protects the wind turbine from damage.
- Shut down may occur in one of several ways. In some machines an automatic brake is activated by a wind speed sensor.



Operating Characteristics of wind mills-2



- Some machines twist or "pitch" the blades to spill the wind.
- Still others use "spoilers," drag flaps mounted on the blades or the hub which are automatically activated by high rotor rpm's, or mechanically activated by a spring loaded device which turns the machine sideways to the wind stream.
- Normal wind turbine operation usually resumes when the wind drops back to a safe level.

Betz Limit:

- It is the flow of air over the blades and through the rotor area that makes a wind turbine function.



Operating Characteristics of wind mills-3



- The theoretical maximum amount of energy in the wind that can be collected by a wind turbine's rotor is approximately 59%.
- This value is known as the Betz limit. If the blades were 100% efficient, a wind turbine would not work because the air, having given up all its energy, would entirely stop.
- In practice, the collection efficiency of a rotor is not as high as 59%. A more typical efficiency is 35% to 45%.
- A complete wind energy system, including rotor, transmission, generator, storage and other devices, which all have less than perfect efficiencies, will deliver between 10% and 30% of the original energy available in the wind.



Mathematical Expression Governing Wind Power



- The wind power is generated due to the movement of wind.
- The energy associated with such movement is the kinetic energy and is given by the following expression:

$$\text{Energy} = KE = \frac{1}{2} m \cdot v^2 \quad \text{Where}$$

$$m = \text{Air mass in Kg} = \text{Volume (m}^3\text{)} \times \text{Density (Kg/m}^3\text{)} = Q \times \rho$$

$$Q = \text{Discharge}$$

$$v = \text{Velocity of air mass in m/s}$$

Hence, the expression for power can be derived as follows:

$$\text{Power} = \frac{dE}{dt}$$



Mathematical Expression Governing Wind Power-1

$$\frac{1}{2} \cdot \frac{d}{dt} \{ m \cdot v^2 \}$$

$$\frac{1}{2} \cdot \frac{d}{dt} \{ \rho \cdot Q \cdot v^2 \}$$

$$\frac{1}{2} \cdot \rho \cdot \frac{dQ}{dt} \cdot v^2$$

Here, $\frac{dQ}{dt}$ = Rate of discharge (m^3/s) = A (m^2) \cdot v (m/s)

Where, A = Area of cross section of blade movement.

$$\text{Power} = \frac{1}{2} \rho \cdot A \cdot v^3$$



Mathematical Expression Governing Wind Power-2



- We know that for given length of blades, A is constant and so is the air mass density ρ .
- Hence we can say that wind power is directly proportional to (wind speed)³.

At sea level, $\rho = 1.2 \text{ Kg/m}^3$. Therefore,

$$Power = \frac{1}{2} \cdot (1.2) \cdot A \cdot v^3$$
$$\frac{Power}{Area} = (0.6) \cdot v^3 = \text{Power Density in watts/m}^2$$



Mathematical Expression Governing Wind Power-3



- Let us construct a chart relating the wind speed to the power density and the output of the wind turbine assuming 30% efficiency of the turbine as shown in the following table.

Wind Speed kmph	Wind speed m/s	Power Density Watts/m ²	Turbine Output 30% efficiency
1	0.278	0.013	0.004
Wind Speed kmph	Wind speed m/s	Power Density Watts/m ²	Turbine Output 30% efficiency
10	2.778	12.860	3.858
25	6.944	200.939	60.282
50	13.889	1607.510	482.253
75	20.833	5425.347	1627.604
100	27.778	12860.082	3858.025
125	34.722	25117.348	7535.204



Mathematical Expression Governing Wind Power-4



➤ The following plot gives the relationship between wind speed in KMPH and the power density.

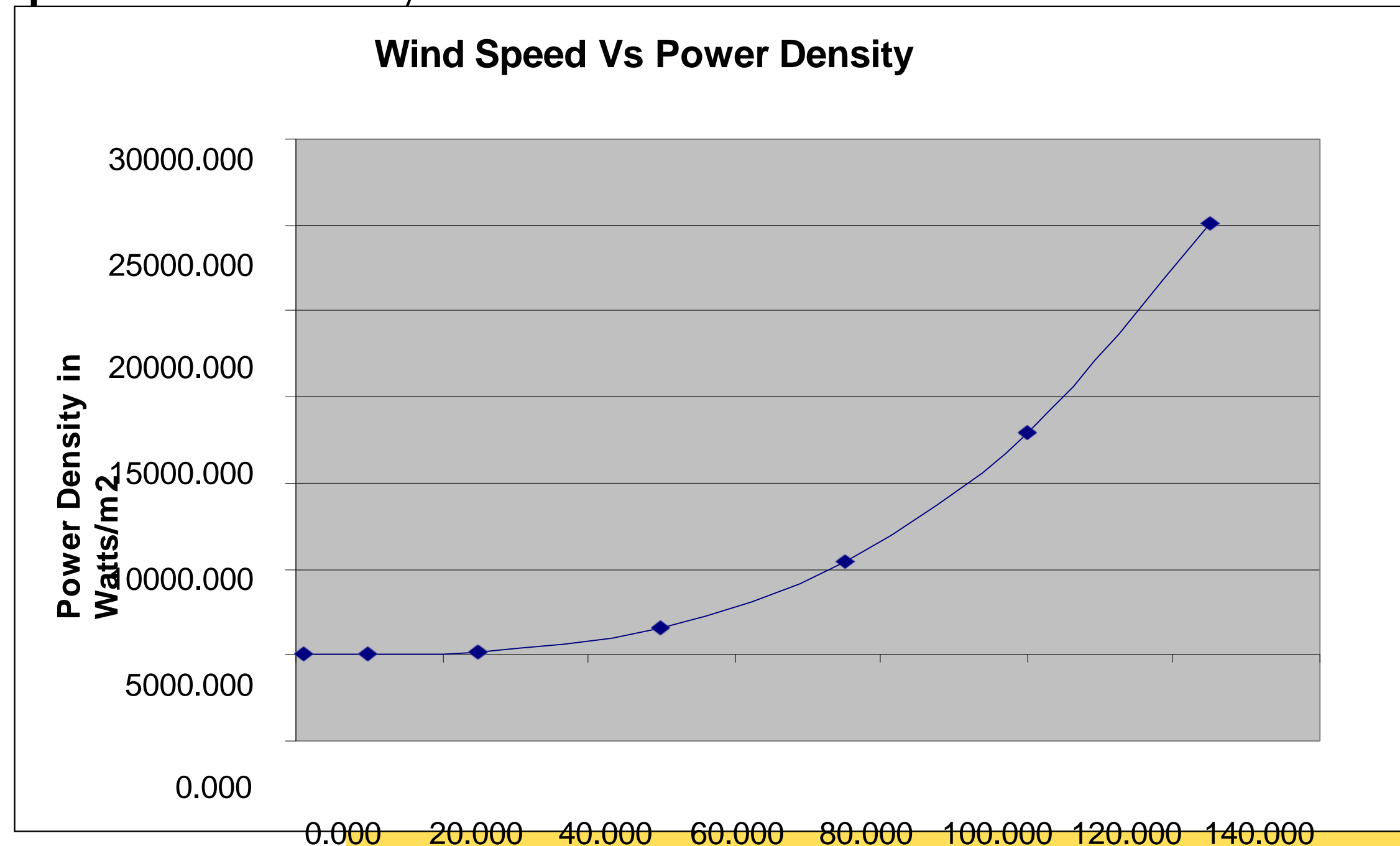



Mathematical Expression Governing Wind Power-5



- In the last column of the table, we have calculated the output of the turbine assuming that the efficiency of the turbine is 30%.
- However, we need to remember that the efficiency of the turbine is a function of wind speed. *It varies with wind speed.*
- Now, let us try to calculate the wind speed required to generate power equivalent to 1 square meter PV panel with 12% efficiency.
- We know that solar insolation available at the PV panel is 1000 watts/m² at standard condition.
- Hence the output of the PV panel with 12% efficiency would be 120 watts.



Mathematical Expression Governing Wind Power-6



- Now the speed required to generate this power by the turbine with 30% efficiency can be calculated as follows:
- Turbine output required = 120 Watts/m²
- Power Density at the blades = 120/ (0.3) = 400 watts/m²
- Therefore, the wind speed required to generate equivalent power in m/s
$$\left(\frac{400}{0.6} \right)^{1/3} = 8.735805 \text{ m/s} = 31.4489 \text{ kmph.}$$
- We have seen that the theoretical power is given by the following expression:
$$P_{\text{theoretical}} = \frac{1}{2} \cdot \rho \cdot A \cdot v^3$$



Mathematical Expression Governing Wind Power-6



- However, there would be losses due to friction and hence, the actual power generated would be smaller.
- The co-efficient of power is defined as the ratio of actual power to the theoretical power. That is,

$$C_p = \frac{P_{actual}}{P_{theoretical}}$$

➤ Another important ratio we need to know is the tip speed ratio.

It is defined as the ratio of tip speed of blade to wind speed. That is,

$$T_R = \frac{\text{Tip Speed of Blade}}{\text{Wind Speed}} = \frac{\omega \cdot \text{radius}}{\text{velocity}} = \frac{(\text{radians second}) \cdot \text{meters}}{(\text{meters second})}$$

In general, C_p is of the order of 0.4 to 0.6 and T_R is of the order of 0.8.



Grid Connection



- We have seen in the previous section the generation of electrical power by the flow of water through turbines.
- The generated electrical power could be dc or ac depending on the type of generator.
- After the power is generated, it needs to be transmitted and distributed to consumers by connecting it to the grid.
- Following figure shows how the grid connection is done. It has the following sections:
 - a) The rectifier.
 - b) The capacitor.
 - c) Switches.



Grid Connection-1



- The rectifier is required if the generated power is ac by alternator or induction generator.
- The capacitor is required to smooth the generated power.
- Switches are required to convert the power to ac to match the grid frequency.
- inductors are required to develop the voltage.

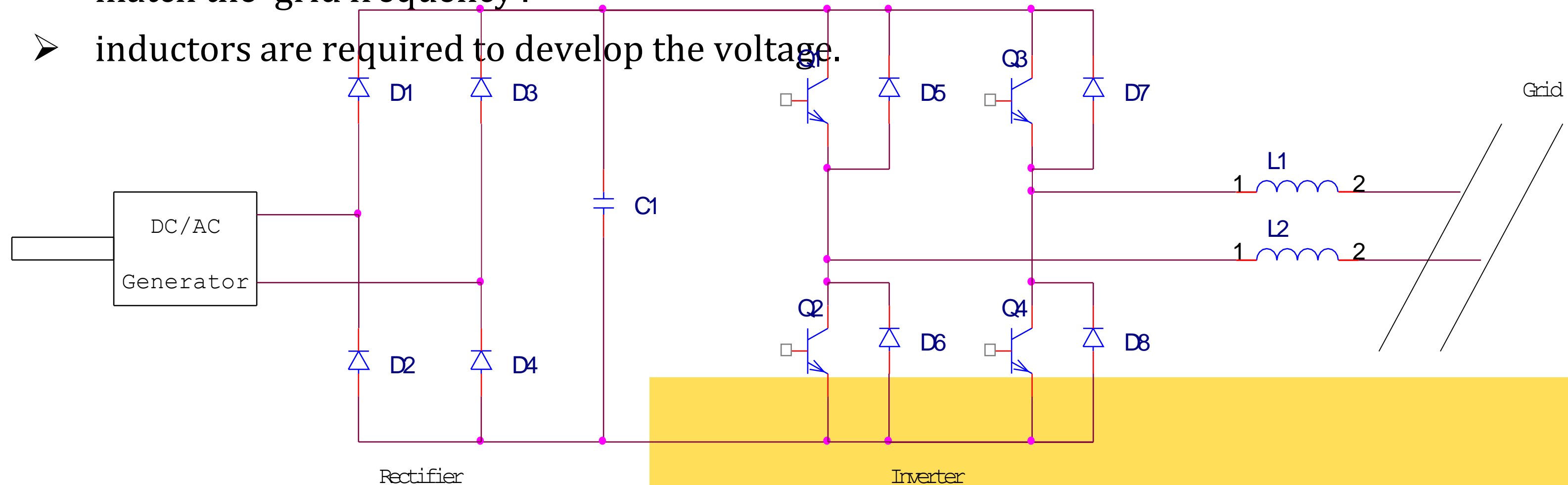



Grid Connection-2

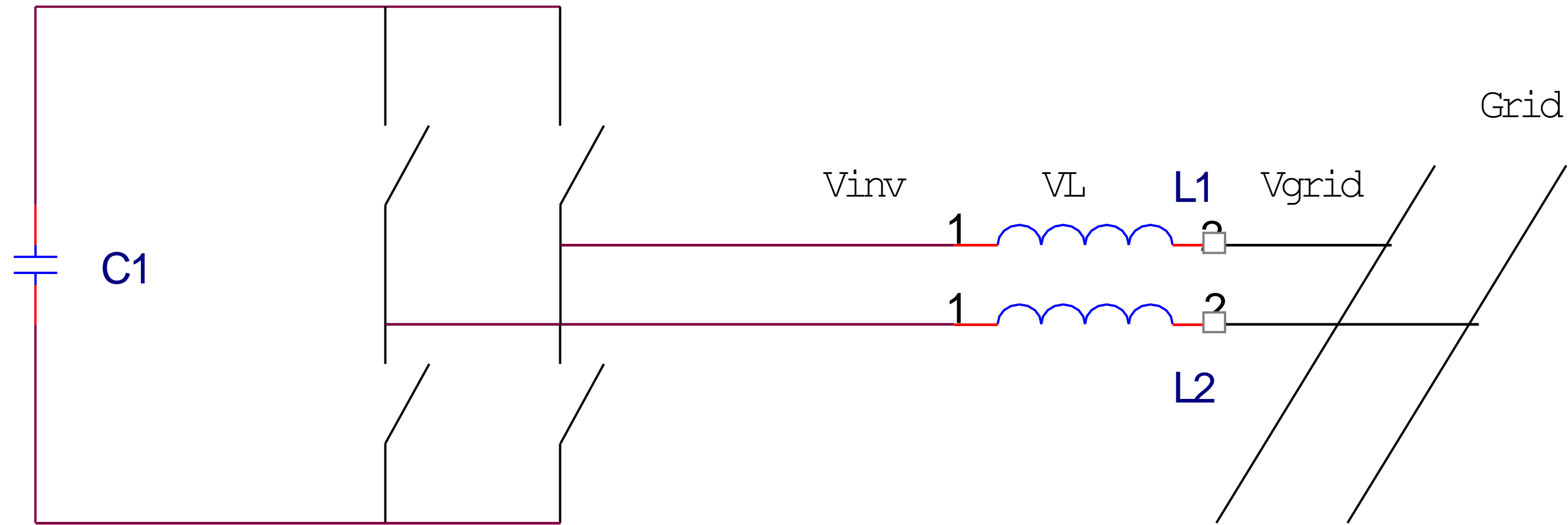

In the above figure,

$$v_L = L \cdot \frac{di_L}{dt}$$

$$i_L = \frac{1}{L} \int v_L \cdot dt$$

Also



Also

$$\frac{di_L}{dt} = \frac{v_L}{L} = \frac{v_{inv} - v_{grid}}{L}$$

The above equation can be realized as follows:

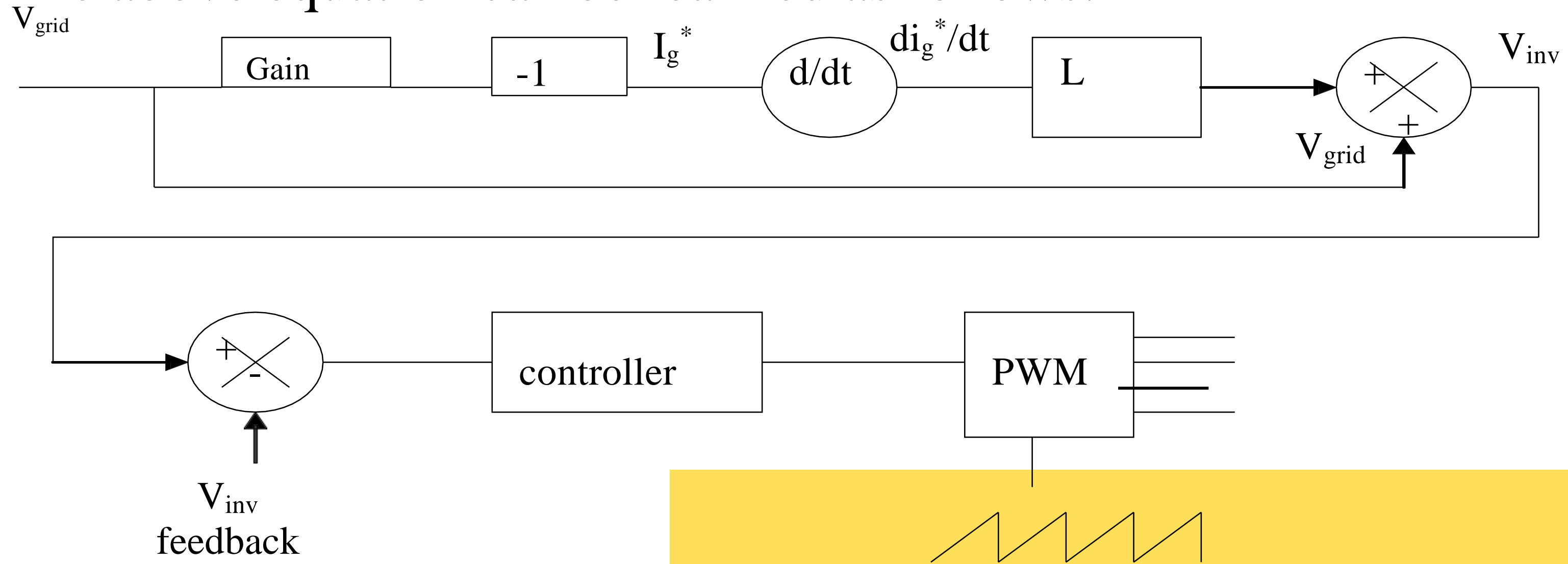



- The starting reference is the grid voltage V_{grid} .
- The current I_g^* proportional to the grid voltage is fed through a differentiator giving dI_g^*/dt .
- This is equivalent to a voltage derivative equation (3). Multiplying this value by L gives $(V_{\text{inv}} - V_{\text{grid}})$.
- Adding this to V_{grid} taken directly from the grid gives V_{inv} .
- This is compared to the actual V_{inv} measured at the output of the inverter.
- If the error is zero, then the voltage across the grid and the voltage at the output of the inverter are same and hence can be connected to each other.
- If there is an error signal then the controller changes the duty cycle of



Grid Connection-5



- Harnessing wind power by means of windmills can be traced back to about four thousand years from now when they were used for milling and grinding of grains and for pumping of water.
- However there has been a renewed interest in wind energy in the recent years as it is a potential source of electricity generation with minimum environmental impact [1].
 - According to present growth the accumulated world wide installed wind electric generation capacity will reach to 50GW at the end of year 2005[2].
 - India has the fifth position in the generation of wind electric generation.



- In India Wind power plants have been installed in Gujarat, Maharashtra, Tamilnadu and Orissa where wind blows at a speeds of 30Km/hr during summer [3] but India has lot of potential for generation of wind power ~~at other places~~ **Grid Connection-6** in Andhra Pradesh, Madhya Pradesh, Karnatka and Kerala.
- The total estimated wind power potential in India is about 45195MW[4].
- Wind electric systems directly feeding to the local load are known as the isolated wind energy system .
- The wind energy system that are connected to grid are known as grid



- Wind is not available all the time for the generation of electric power
- power output of wind turbine is proportional to the cube of the velocity of wind and the power output is optimal for a particular wind velocity.
- So Large wind electric generator (WEG) systems are connected to utility grid where they feed the power to grid.
- The connection of cage rotor Induction Generator to grid again cause the problems in terms of drawing large magnetizing current from grid at very low power factor.
- Under the low wind conditions when the machine draws only reactive power from grid and stator power factor is very poor.



- Lagging power factor is compensated by connecting capacitor banks across the line.
 - Depending on the active power generated these capacitors are either cut-in or cut out to regulate the power factor.
- Grid Connection-8**
- The switching of capacitors may cause the over voltage in power system [1].
 - So various techniques for connecting the WEG to grid has been proposed [2,5,6].
 - The stand -alone system can be better utilized by using load-matching techniques [7].



Wind Energy Regions in India



- India has several on shore and off shore wind energy sites.
- India has a lot of scope in terms of harnessing wind power using these sites.
- The state wise estimated wind power potential in India is shown in table1 (Gross potential is based on assuming 1% of land availability for

wind power generation in potential areas.)

Si No.	State	Gross Potential (MW)	Total Capacity(MW) (31-09-04)	Technical Potential (MW)
1	Andhra Pradesh	8275	101.3	1750
2	Gujarat	9675	218.5	1780
3	Karnataka	6620	274.2	1120



Wind Energy Regions in India-1

Si No.	State	Gross Potential (MW)	Total Capacity (MW) (31-09-04)	Technical Potential (MW)
4	Kerala	875	2	605
5	Madhya pradesh	5500	26.35	825
6	Maharashtra	3650	411.15	3020
7	Rajasthan	5400	212.0	895
8	Tamilnadu	3050	1683.6	1750
9	West Bengal	450	1.1	450
10	Others	2990	3.1	-
11	Total (All India)	45195	2884.75	12875



Wind Energy Regions in India-2



- WEG of 2 MW capacity is installed in suzlon (Tamilnadu) is the largest power rating in India.
- Maximum WEG installations are in Tamilnadu of capacity about 1639MW.
- Maximum gross estimated Wind potential is in Gujarat of 9675 MW.
- The map of India is shown below indicating the various wind energy sites in India.



Wind Energy Regions in India-3

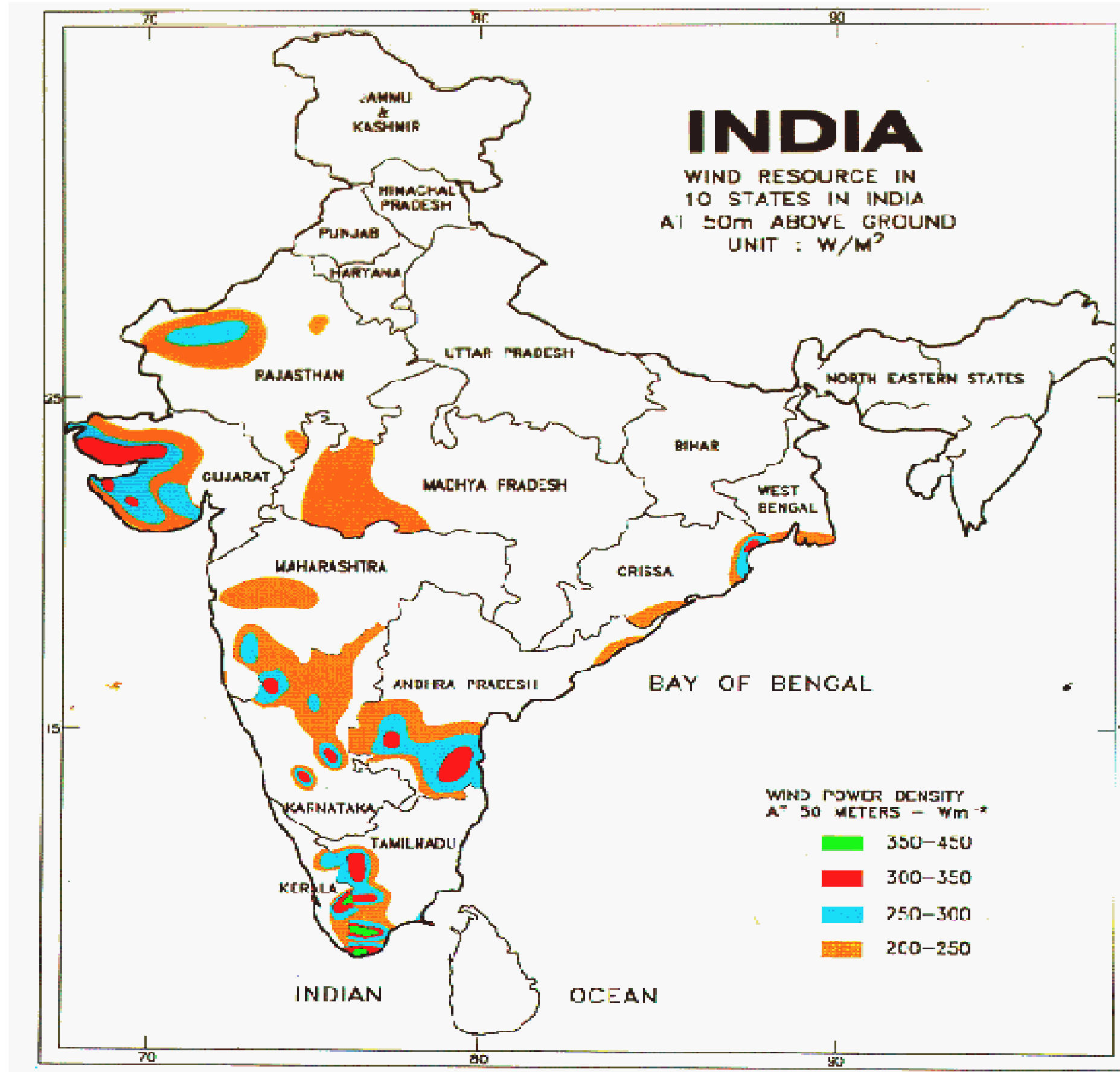



Limitations of Present day WEG 's:

- Most of the present day WEG 's are the constant speed installations.
- These WEG'S have some limitations as given below

A-Poor Energy Capture

- *This is due to low aerodynamic efficiency of WEG and the variation in efficiency over the entire operating range.*

Power output of turbine $P_t = .5 C_p \rho A v^3$

$\rho =$ Air density, $A =$ swept area, $v =$ wind velocity, C_p is called the power coefficient and is dependent on the linear velocity of the blade tip ($R\omega$) and the wind velocity (v).

The ratio, known as the tip-speed ratio, is defined as

$\lambda = R\omega / v$ where R is the radius of the turbine



Wind Energy Regions in India-5

- From fig 1 it is observed that the power coefficient is maximum for a particular tip ratio. So power capture is not optimum at other wind velocity.

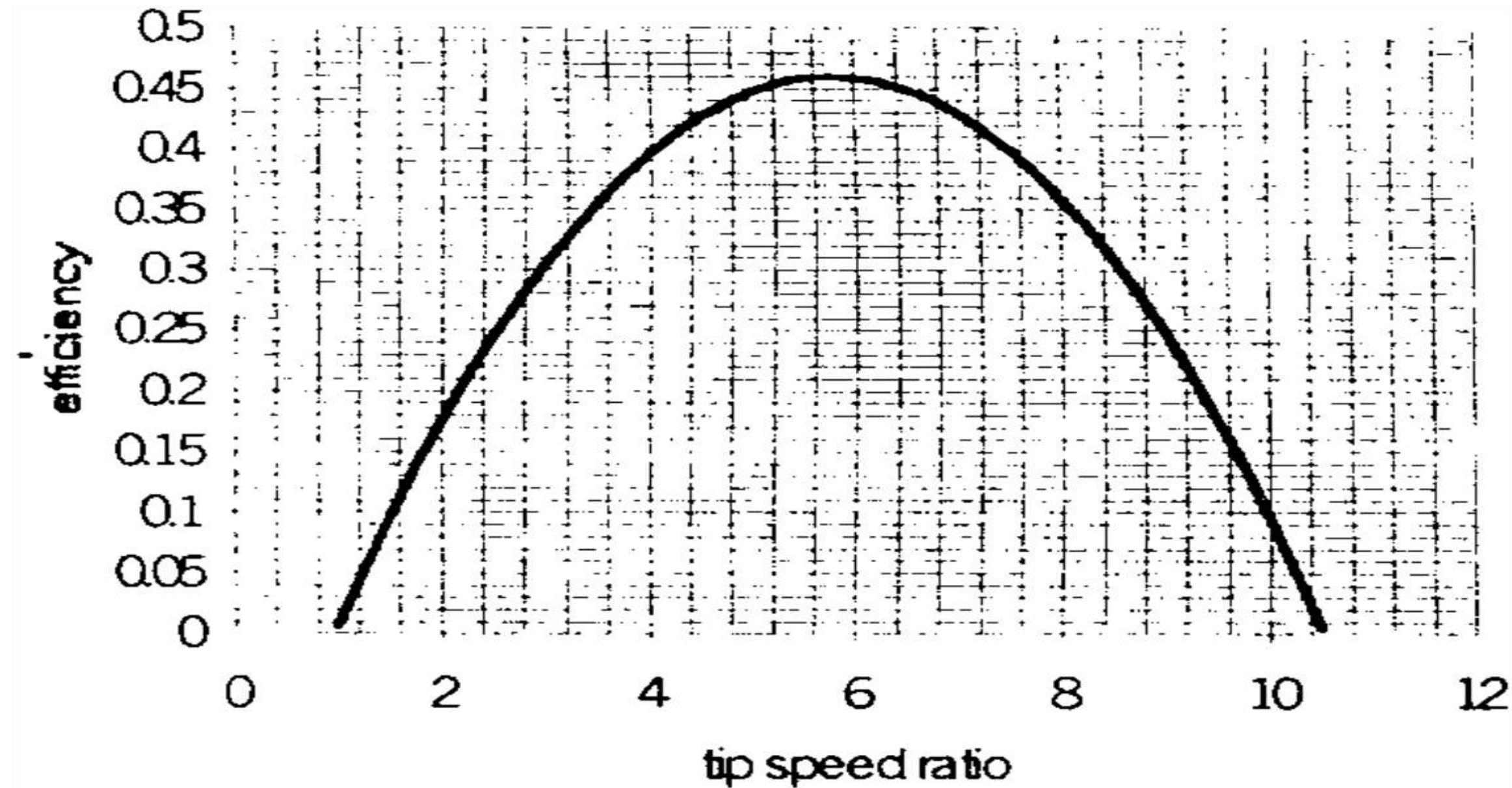



Wind Energy Regions in India-6



B-Reactive Power Consumption

- Since most WEG 's employ induction generators as electromechanical energy converters these WEG 's draw reactive power from grid for excitation.
- This leads to additional T&D losses and changes in voltage stability margins.

C- Unstable grid frequency

- Most WEG 's have their blade design based on expected speed of the IG (grid frequency).
- The aerodynamic efficiency greatly reduces when the grid frequency is not maintained a constant at the specified level due to the changes in the



Wind Energy Regions in India-7



- By considering above-mentioned problems it is preferable to run WEG at variable speed.
- A variable speed WEG enables enhanced power capture as compared to constant speed WEG.
- The rotor speed can be made to vary with changing wind velocity so the turbine always operates with max C_p within the power and speed limits of the system.
- Various control schemes are used for both Isolated WEG and grid connected WEG running at variable speed.



Isolated WEG:

A- Load Matching

- When wind driven self excited Induction generator (SEIG) running at variable Speed.
 - it is essential that the power output of the generator increase with increasing power input to the prime mover.
 - which in the case of wind turbine varies approximately as the cube of the wind speed.
 - If this load matching is not planned properly, the generator would either over speed at high wind speed or come out of excitation at low wind speeds.



Wind Energy Regions in India-9



- since the output voltage and frequency of the generator varies with wind speed for many applications requiring constant voltage.
- some kind of power electronic controller is needed between the generator and load. Fig shows a scheme employing a PWM inverter to obtain the voltage of required magnitude and frequency at the load terminal.
- Loads are connected through control switch, which could appropriately be activated by monitoring the wind speed as shown in the fig2.



Wind Energy Regions in India-10

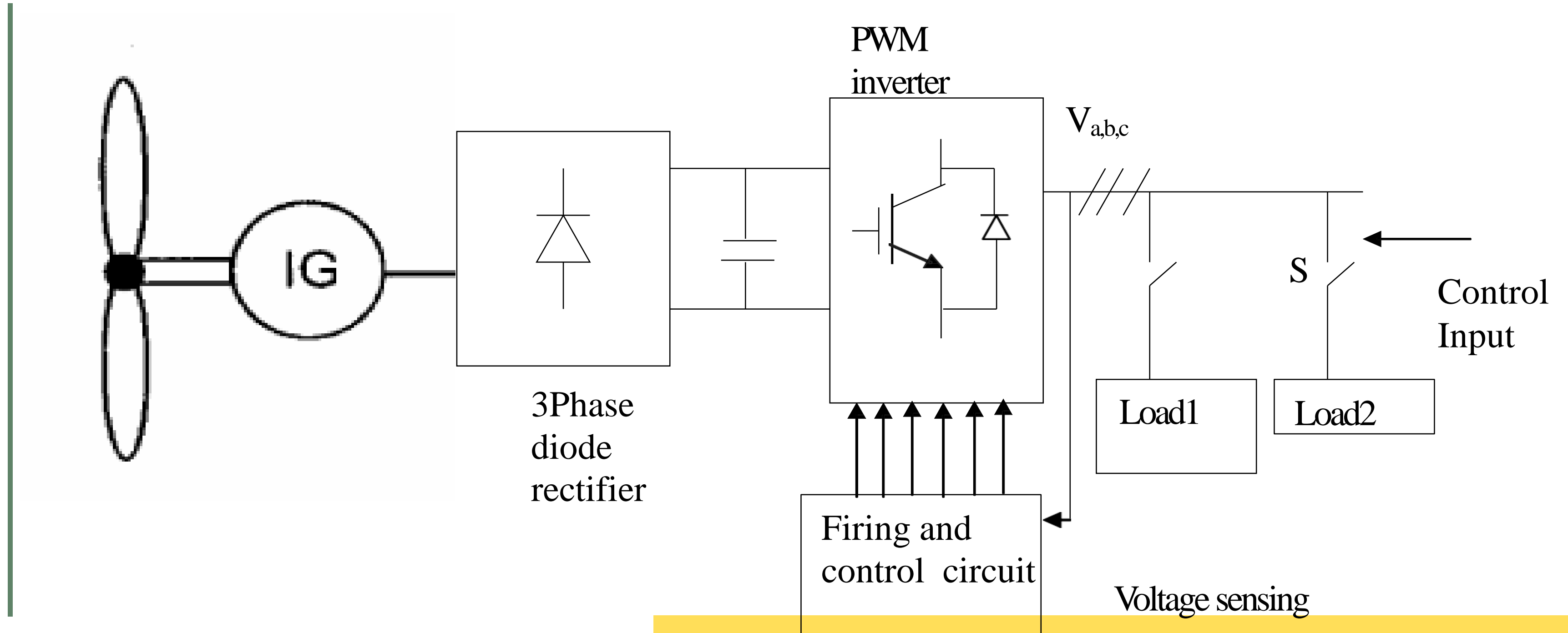



Wind Energy Regions in India-11



B- *Scalar Control of IG :*

- Scalar control of IG means control of magnitude of voltage and frequency so as to achieve suitable speed with an impressed slip.
- Scalar control disregards the coupling effect on the generator; that is, the voltage will be set to control the flux and the frequency in order to control the torque.
- If the IG is primarily in stand-alone operation, reactive power must be supplied for proper excitation.
- The overall scheme of control is shown below in fig3.



Wind Energy Regions in India-12

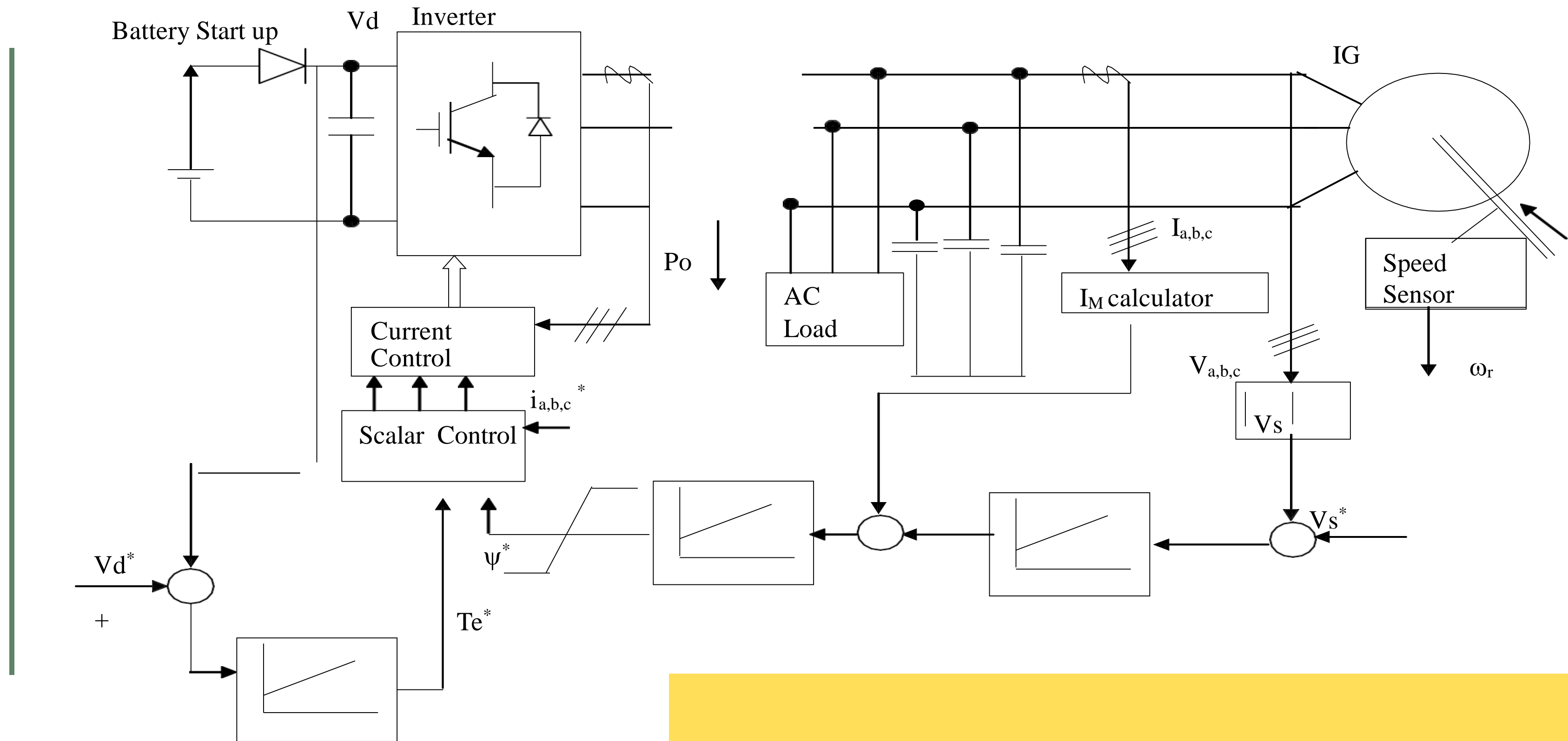



Wind Energy Regions in India-13



- The capacitor bank is bulk uncontrolled source of reactive current.
- The static VAR compensator is an inverter providing a controlled source of reactive current.
- Machine torque and flux input will be used in this application to regulate both DC link voltage at the capacitance C and generator voltage supplied for the AC load.
- These regulators have to reject the disturbances produced by load and speed variations.
- A DC link voltage regulator has been implemented to achieve high enough DC link voltage for proper current controlled inverter operation.
- The regulator input is the difference between the DC link reference and measured value.



Wind Energy Regions in India-14



- At the generator side terminal current and voltages are measured to calculate the magnetizing current needed for the generator,
- The instantaneous peak voltage is compared to the stator voltage reference, which generates a set point for flux through the feedback loops on the inverter side.
- This system requires a charged battery startup. That can be recharged with an auxiliary circuit after the system is operational.
- Since stator voltage is kept constant the frequency can be stabilized at about 50Hz for the AC load,
- but some slight frequency variation is still persists and the range of turbine shaft variation should be within the critical slip in order to avoid instability.
- Therefore AC loads should not be too sensitive for frequency variation in this stand-alone application



C- Vector Control of IG

- The decoupled flux and torque control of IG is known as vector control.
- For an IG operating in stand- alone mode, a procedure to regulate the output voltage is required as shown in the fig4.
- The DC link voltage across the capacitor is kept constant and machine impressed terminal frequency will vary with variable speed.
- Since the frequency of generated voltage depends on the wind speed (rotor speed).
- the product of the rotor speed and the flux linkage should be remain constant so that the terminal voltage will remain constant.



Wind Energy Regions in India-16



- where the maximum rotor speed corresponding to maximum saturated flux linkage.
- The system starts up with a battery connected to the inverter.
- Then, as the system DC link voltage is regulated a higher value across the capacitor, the battery will be turned off by the diode and the DC load can be supplied across the capacitor.
- The machine terminals are also capable of supplying the power to an auxiliary load at variable frequency.



Wind Energy Regions in India-17

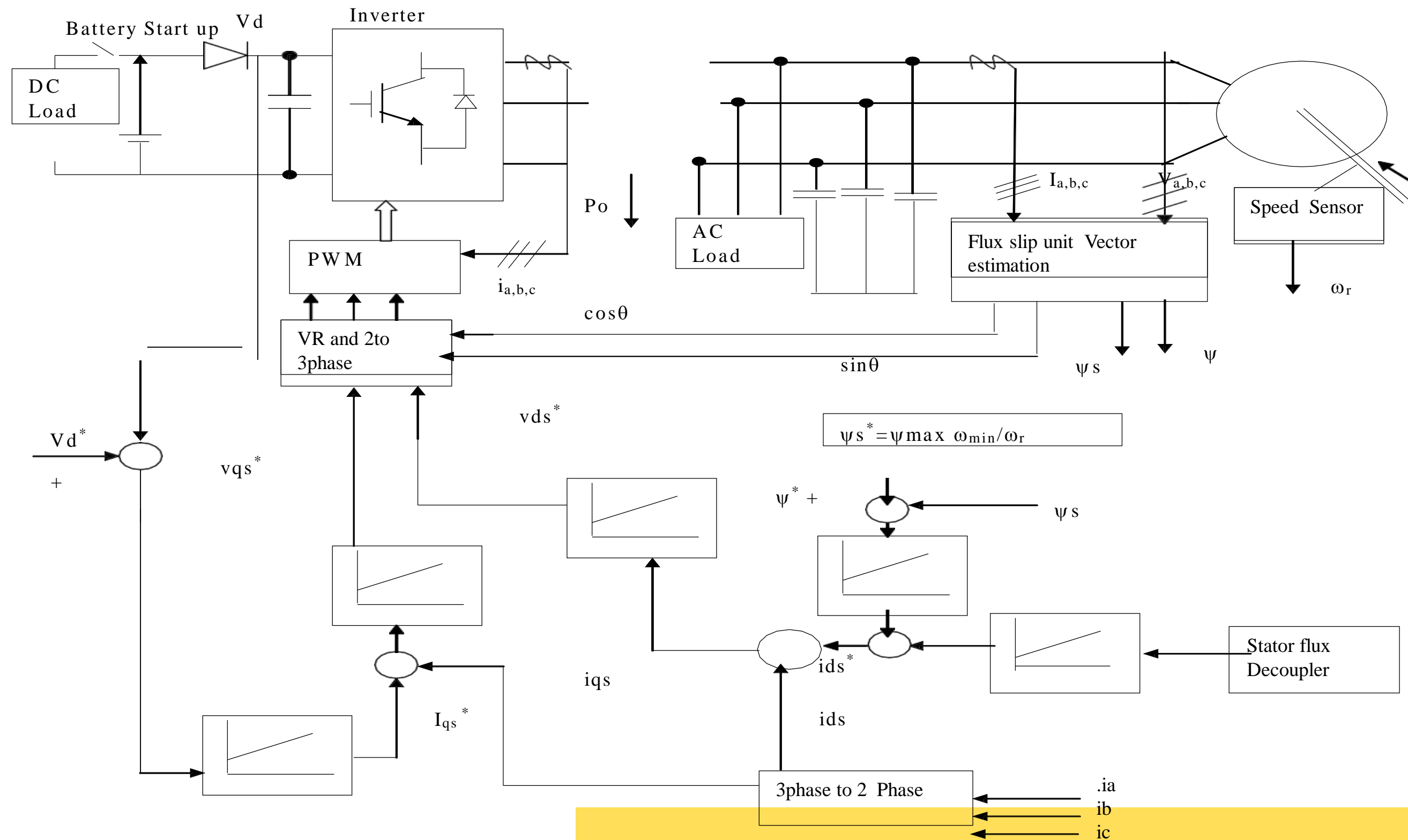



Generator Connected to Grid:

A -Scalar Control

- *A current –fed link system for grid connection with constant V/Hz is depicted in fig5.*
- *The DC link current allows easy bi-directional flow of power.*
- *Although the DC link current is unidirectional.*
- *A power reversal is achieved by a change in polarity of the mean DC link voltage and symmetrical voltage and symmetrical voltage blocking switches are required.*



Wind Energy Regions in India-19



- *A thyristor -based controlled rectifier manages the three phase utility side and machine side inverter can use a transistor with a series diode.*
- The system is commanded by the machine stator frequency reference (ω^*e).
- A PI control produces set point for DC link current, and firing for the thyristor bridge controls the power exchange (P_o) with the grid.
- The stator frequency reference ω^*e can be varied in order to optimize the power tracking of IG.



Wind Energy Regions in India-20

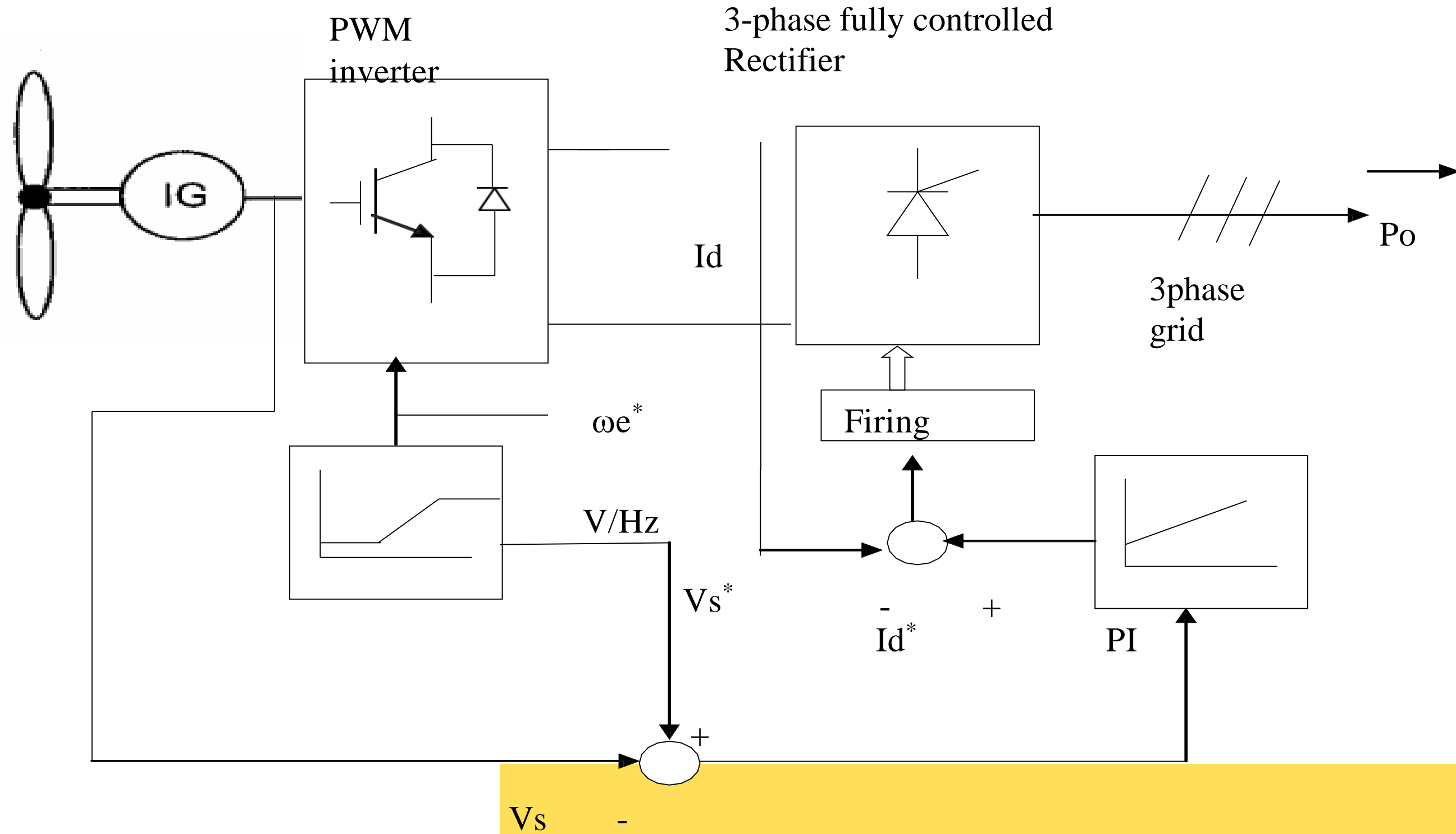



B-Vector Control:

- *Squirrel cage and Wound rotor IG are commonly used in WEG 's.*
- *These machines have different control strategies.*
- *The WRIG is more advantageous as compared to SQIG for variable speed constant frequency (VSCF) type of operation.*
- *The variable frequency, variable voltage power generated by the machine is converted to fixed frequency.*
- *fixed voltage power by the power converter and supplied to the grid.*
- *The power converter supplies the lagging excitation current to the machine while the reactive power is supplied to the utility grid can be controlled independently as shown in fig6.*



Wind Energy Regions in India-22



- The converter is a back-to-back two level converter but the converter could be theoretically any 3-phase converter allowing by bi-directional power flow.

3-phase fully controlled

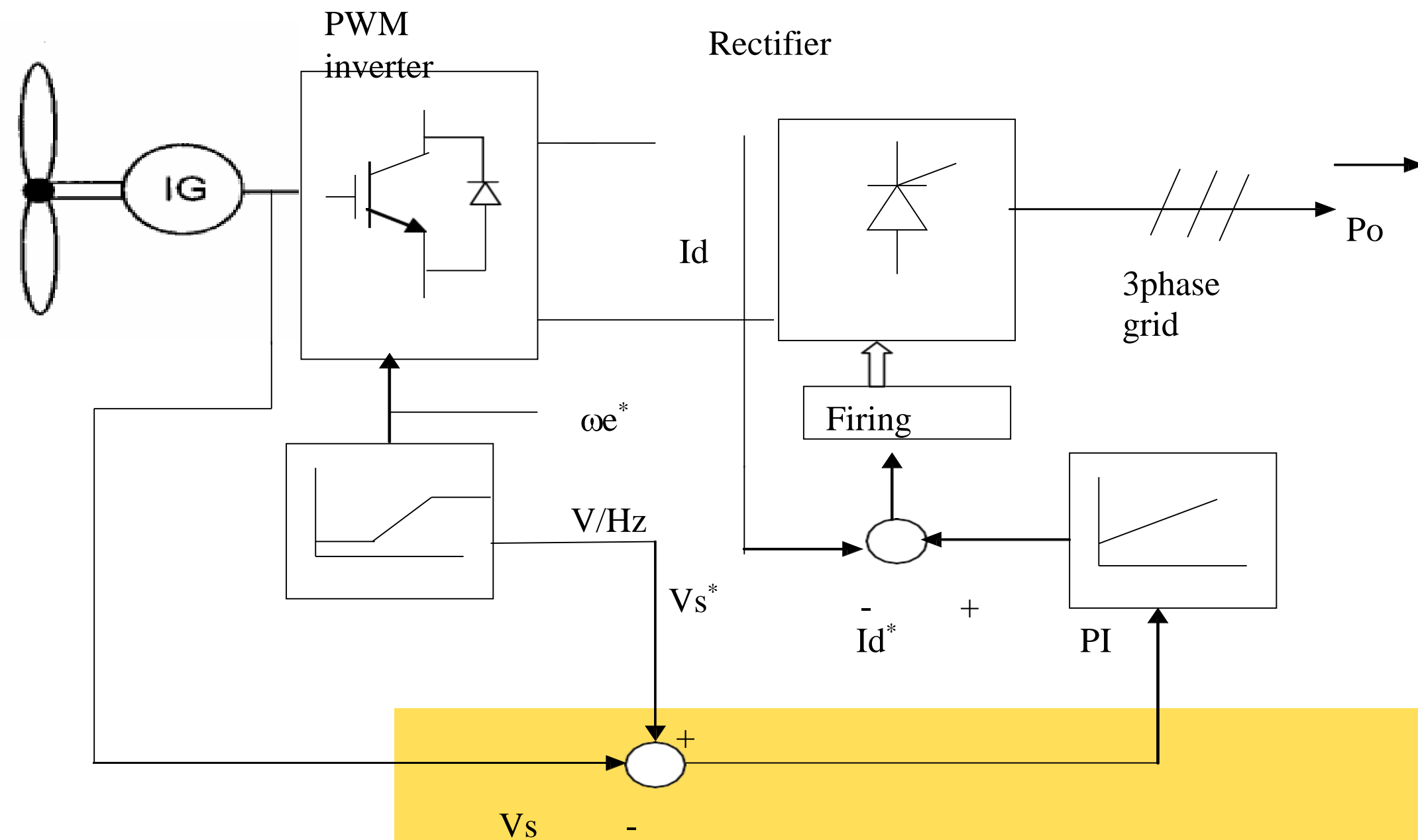



Generator-Inverter Control:

- *Input to the generator-inverter control scheme is the desired electromechanical torque at the generator shaft.*
- *From the torque reference, the flux reference is calculated- alternatively: the flux reference level may be set manually.*
 - *Based on measurements of the generator voltages and currents, the actual flux and torque are estimated and compared with their respective reference values.*
- *The error is input to a hysteresis controller.*
- *Based on the output from these two hysteresis controllers the desired switch vector is chosen.*



Wind Energy Regions in India-24



- In order to track the maximum power point, the maximum power point algorithm can be used to set the torque as described in [1].
- To control the active power through the grid inverter, the dc-link voltage is measured and compared to the actual dc-link voltage.
- The dc-link voltage error is fed to a PI-controller having a power reference as output.
- To provide a fast response of the grid inverter control, the measured power from the generator measured in the dc-link, is fed forward.
- The power error is input to another PI controller, giving the active current reference as output.



Wind Energy Regions in India-25



- The active current reference is compared to the actual active current all transformed to the synchronously rotating reference frame.
- The current error is then fed into a third PI controller having the q-axis voltage reference as output.
- Similarly, the reactive current reference is compared to the actual reactive current and the error is input to a PI controller having the d-axis voltage reference.
- These 2 d and q voltage references are transformed back to stationary reference frame and the gate signals are calculated.



Wind Energy Regions in India-26



- Above scheme has following advantages as compared to conventional system
- 1-For same turbine it allows higher power capture, thereby increasing the annual energy output significantly.
- 2-This system is capable of providing the reactive power of IG from DC bus capacitance.
- 3-Since the torque of the machine is controlled the generator cannot be overloaded at any point of time beyond the prescribed limits.



Wind Energy Regions in India-27



- Doubly Fed Induction Generator (DFIG):
- Compared to the squirrel-cage induction generator, the main difference is that the doubly fed induction generator provides access to the rotor windings,
- thereby giving the possibility of impressing a rotor voltage.
- By this, power can be extracted or impressed to the rotor circuit and the generator can be magnetized from either the stator circuit or the rotor circuit.
- Speed control can be applied to the doubly fed induction generator by slip power recovery scheme. Figure7 slip-power recovery scheme.



Wind Energy Regions in India-28

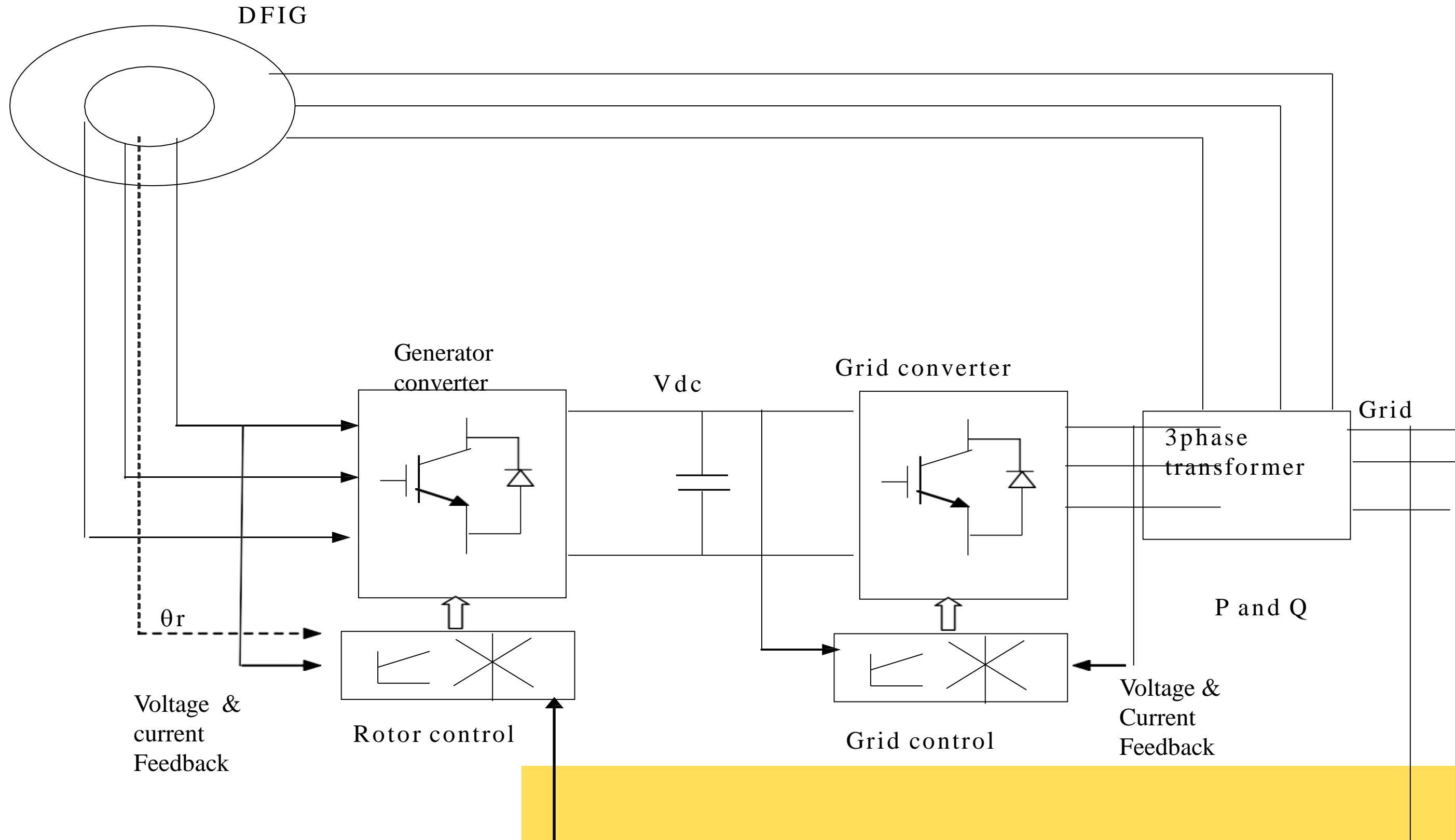



Wind Energy Regions in India-29



Slip power recovery scheme:

- The doubly fed induction generator is controlled by a bi-directional power converter- in the present diagram back-to-back two-level converter.
- By this scheme, the generator can be operated as a generator at both sub- and super synchronous speed and the speed range depends only on the converter ratings.
- Besides nice features such as variable-speed operation, active and reactive power control, and fractional power conversion through the converter.



Wind Energy Regions in India-30



- The system suffers from the inevitable need for slip rings, which may increase the maintenance of the system and decrease its reliability.
- The system comprises a step-up gear.
- The two inverters-the gridside inverter and the rotor side inverter-in Fig. 8 can be controlled independently.
- And by a proper control the power factor at the grid side can be controlled to unity or any desired value.
- By more sophisticated control schemes the system can be used for active compensation of grid-side harmonics.



Wind Energy Regions in India-31



Rotor-Converter Control Scheme :

- Inputs to the control structure are the desired active and reactive power along with the measured rotor currents and measured active and reactive power.
- The error between measured active/reactive power and reference values are fed into a PI-controller giving d and q axis rotor reference currents.
 - These current references are compared to the actual currents and the errors are inputs to a set of PI-controllers giving the d and q axis rotor voltage references *as* outputs.
- From these voltage references the gating signals *for* controlling the rotor inverter are calculated,



Wind Energy Regions in India-32



- the detection of the slip angle can either be done by the use of an optical encoder or by position-sensor less schemes.
- The grid -inverter control scheme is similar to cage rotor grid – inverter control scheme.
- Above scheme has following advantages as compared to cage rotor IG.
- 1-The ratings of the converters are significantly reduced.
- 2-A lower DC bus voltage is required. This reduces the voltage rating of capacitor banks.



Connection of Large Wind Farm to grid with Asynchronous Link:

- Previously, wind turbines were sited on an individual basis or in small concentrations making it most economical to operate each turbine as a single unit.
- Today and in the future, wind turbines will be sited in remote areas (including off-shore sites) and in large concentrations counting up to several hundred megawatts of installed power.
- For such a large system, using asynchronous link can give the best interconnection to grid especially for weak AC system. HVDC system can give such type of asynchronous link.



Wind Energy Regions in India-34



- Today most wind farms and single units are directly connected to the AC-grid.
- With increasing wind power coming on line, it is today, Already difficult to enter high amount of wind power in often weak Part of the AC-network.
- The development towards big wind farms will in most cases make it necessary to have an interface between the wind farm and the AC-grid.
- This is because out-put from a wind generator generates disturbances to the AC-grid, which is not acceptable.
- In order to maintain power quality and stability, the AC-grid must



Wind Energy Regions in India-35



- If the AC-grid is strong, i.e. the short circuit capacity is high in relation to the capacity of the wind farm.
- it may be possible to connect the farm directly to the grid.
- However, wind farms are often located in areas where the AC- grid is very weak, and can therefore not be directly connected.
- The introduction of HVDC Light now offers an alternative, superior to other techniques HVDC Light.
- HVDC Light is the ideal interface between any wind farm and any AC grid. Fig gives the connection of individual wind power generator to the grid through the central power converter.
- Each wind turbine contains a power converter connected to the



Wind Energy Regions in India-36



- This HVDC park solution provides all the features of variable speed concept since all the turbines are connected independently.

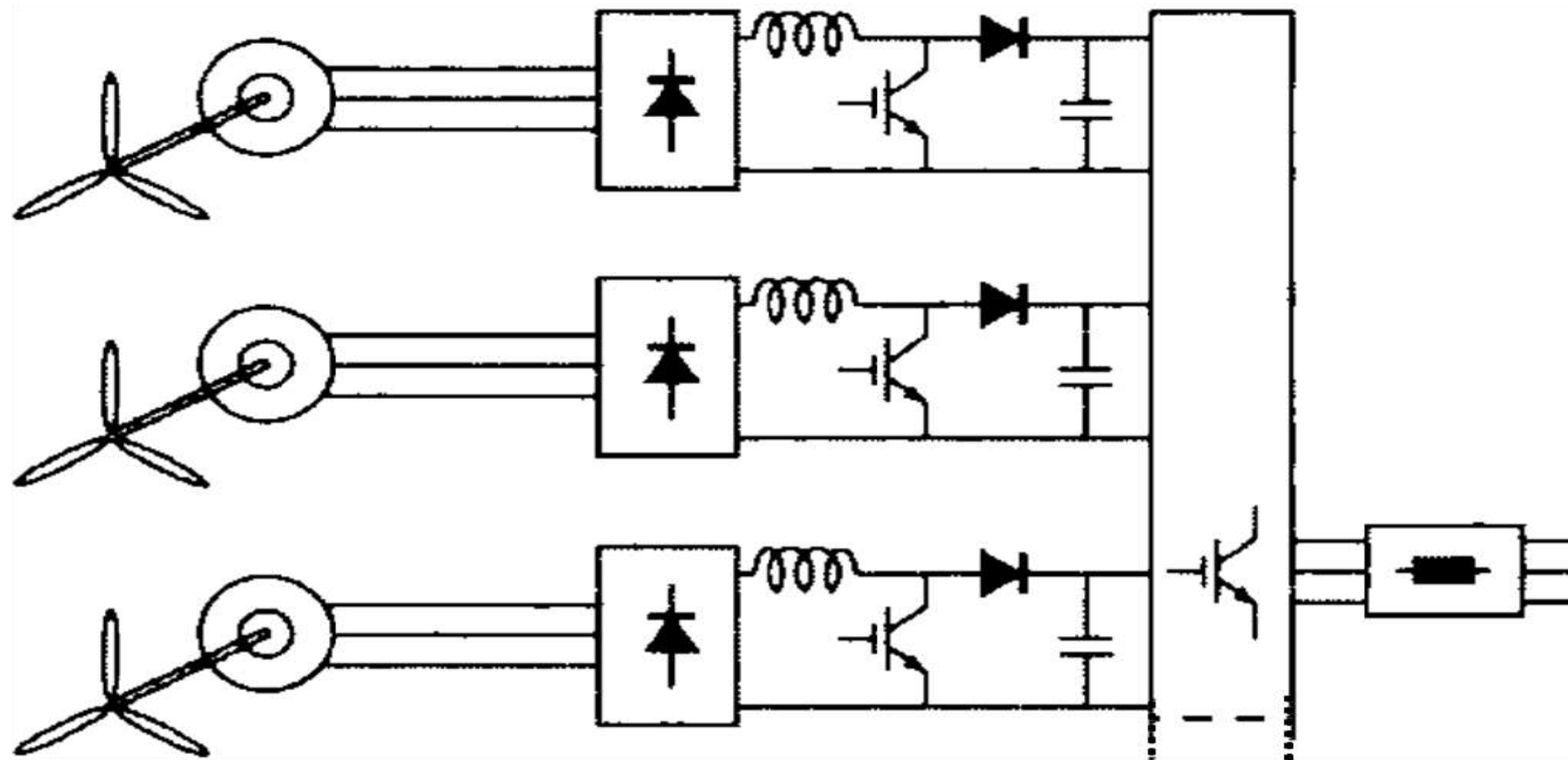



Wind Energy Regions in India-37



The main features are

- **1-** the distance from the farm to the connection point in the AC- grid has no technical limitations.
- **2-** the wind farm is from a disturbance point of view isolated from the AC-grid.
- **3-** HVDC Light generates the reactive power needed by the generators.
- **4-** the power quality at the connection point is improved.
- **5-** Controlled power production. During periods with reduced transmission capacity in the grid, the wind farm must be able to operate at reduced power levels with all turbines running.



Conclusion:

- A comparison with existing scheme shows, that for a machine of similar rating energy capture can be enhanced by using wound rotor induction generator.
- In this case rated torque is maintained at super synchronous speeds whereas in a system using cage rotor IG, field weakening has to be employed beyond synchronous speed leading to the reduction in torque.
- Although DFIG has more advantages as compared to other methods but it has drawbacks in terms of complex control structure and maintenance problems as compared to cage rotor IG.
- The use of HVDC link for large wind farms is the best choice in terms of advantages of grid interaction and long distance power transmission.