



SNS COLLEGE OF TECHNOLOGY

Coimbatore-35
An Autonomous Institution

Accredited by NBA – AICTE and Accredited by NAAC – UGC with 'A+' Grade
Approved by AICTE, New Delhi & Affiliated to Anna University, Chennai



DEPARTMENT OF AGRICULTURAL ENGINEERING

19AGB301 - FARM TRACTORS
III - YEAR , 5 th Semester

Topic : Valve and valve mechanism



What is Engine Valves?

👉 A valve is a device to close and open a passage. Engine valves are devices that are used in internal combustion engines to allow or stop the flow of fluid or gas from cylinders or combustion chambers during the engine while the engine is operating.



Engine Valves



👉 These are also known as check valves which are used for air injection in vehicles as part of emission control and exhaust gas recirculation systems. Engine valves are commonly employed in every type of combustion engine such as gasoline, diesel, kerosene, natural gas, or propane.



Inlet Valve

👉 Fuel is allowed to the cylinder by the inlet valve. When closed, the valve seals the combustion space tightly. The valves are usually made of austenitic stainless steel which is a corrosion and heat-resisting material. Inlet valve is subjected to less heat is usually made of nickel-chromium alloy steel.



👉 **Diagram that represents the valve**

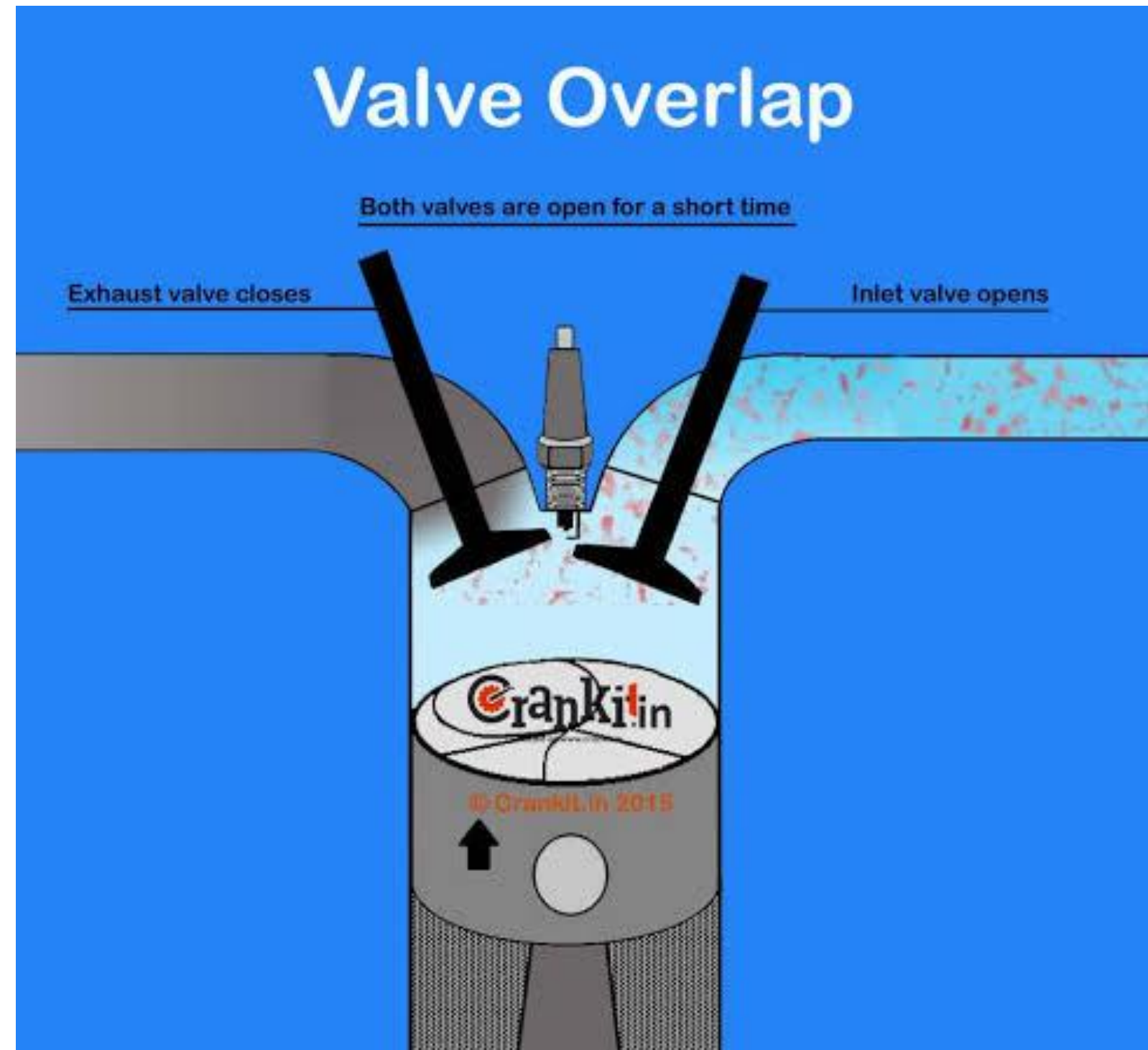



Exhaust Valve



👉 **The burned gases escape by the exhaust valve. The exhaust valve is usually made of silichrome steel which is an alloy of silicon and chromium with unusual resistance to heat.**

👉 **The valves used in car engines are termed poppet or mushroom valves. The head of the valve has an accurately ground face with enough margin left to avoid a thin edge.**



Valves

👉 The angular face is ground on the valve head to make an angle of 45° or 30° to match the angle of the valve seat in the cylinder head. Spring retainer lock grooves are provided at the end of the valve stem.



👉 **Double tap too see
it**

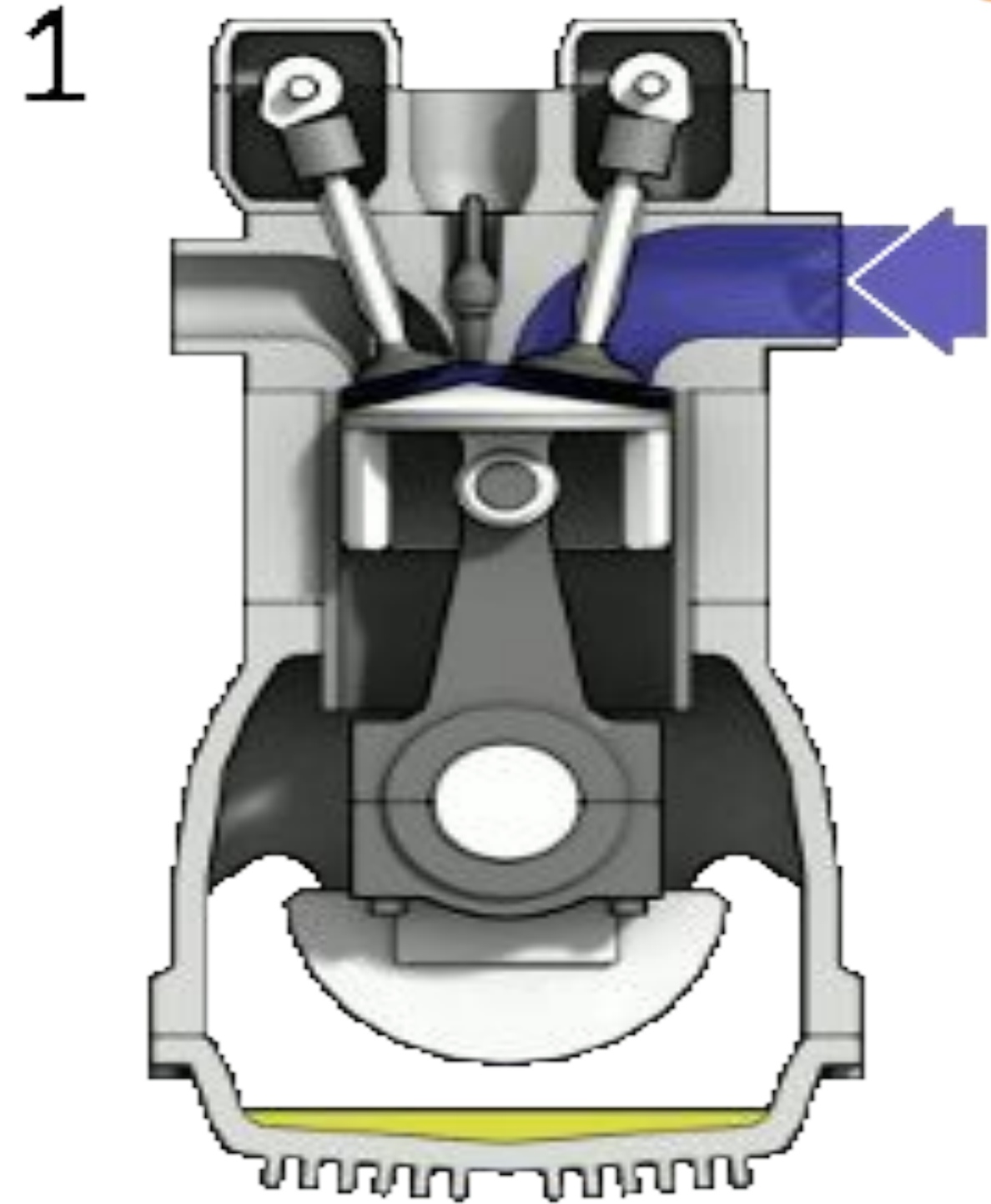



Types of Engine Valves



There are 3 different types of engine valves as follows:

- 👉 Poppet valve**
- 👉 Sleeve valve**
- 👉 Rotary valve**
- 👉 Reed valve**



#1 Poppet Valve

It is also known as a mushroom valve because of its shape. It is used to control the timing and quantity of gas flow into an engine. This is the most widely used valve in an automobile engine. The poppet valve is given the name because of its motion of popping up and down.



Poppet Valve



It consists of a head and a stem. The valve face usually with an angle of 30° to 45° is ground perfectly, since it has to match with the valve seat for perfect sealing.



👉 Poppet valve

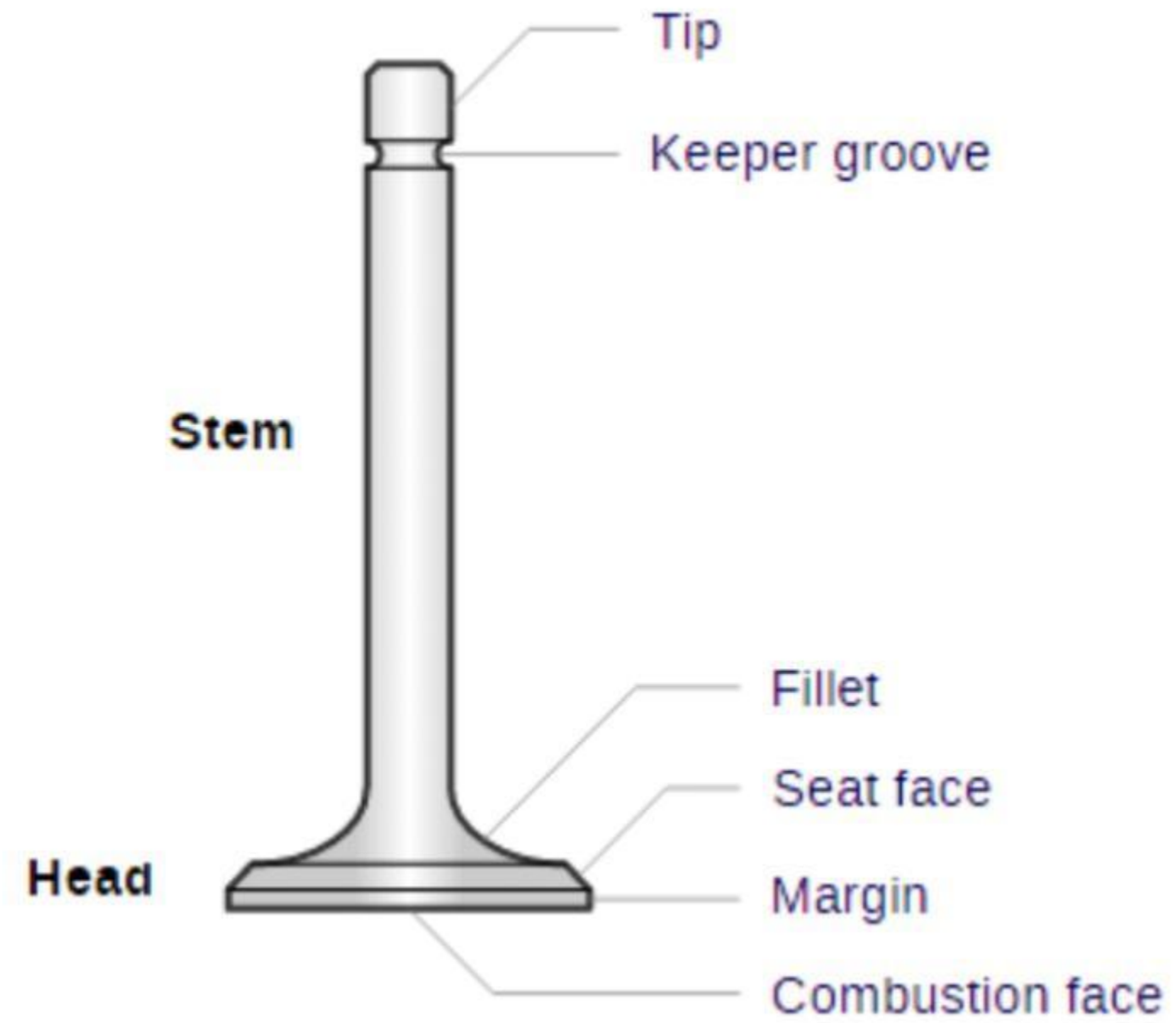



The stem has a spring retainer lock groove and its end is in contact with the cam for up & down movements of a valve. In exhaust, a pressure differential helps to seal the valve. In intake valves, the pressure differential helps open them.



#2 Sleeve Valve



👉 The sleeve valve as the name implies is a tube or sleeve that fits between the piston and the cylinder wall in the cylinder of an internal combustion engine, where it rotates/slides.

👉 Ports on the side of the sleeves come into alignment with the cylinder's inlet and exhaust ports at the appropriate stages in the engine's cycle.

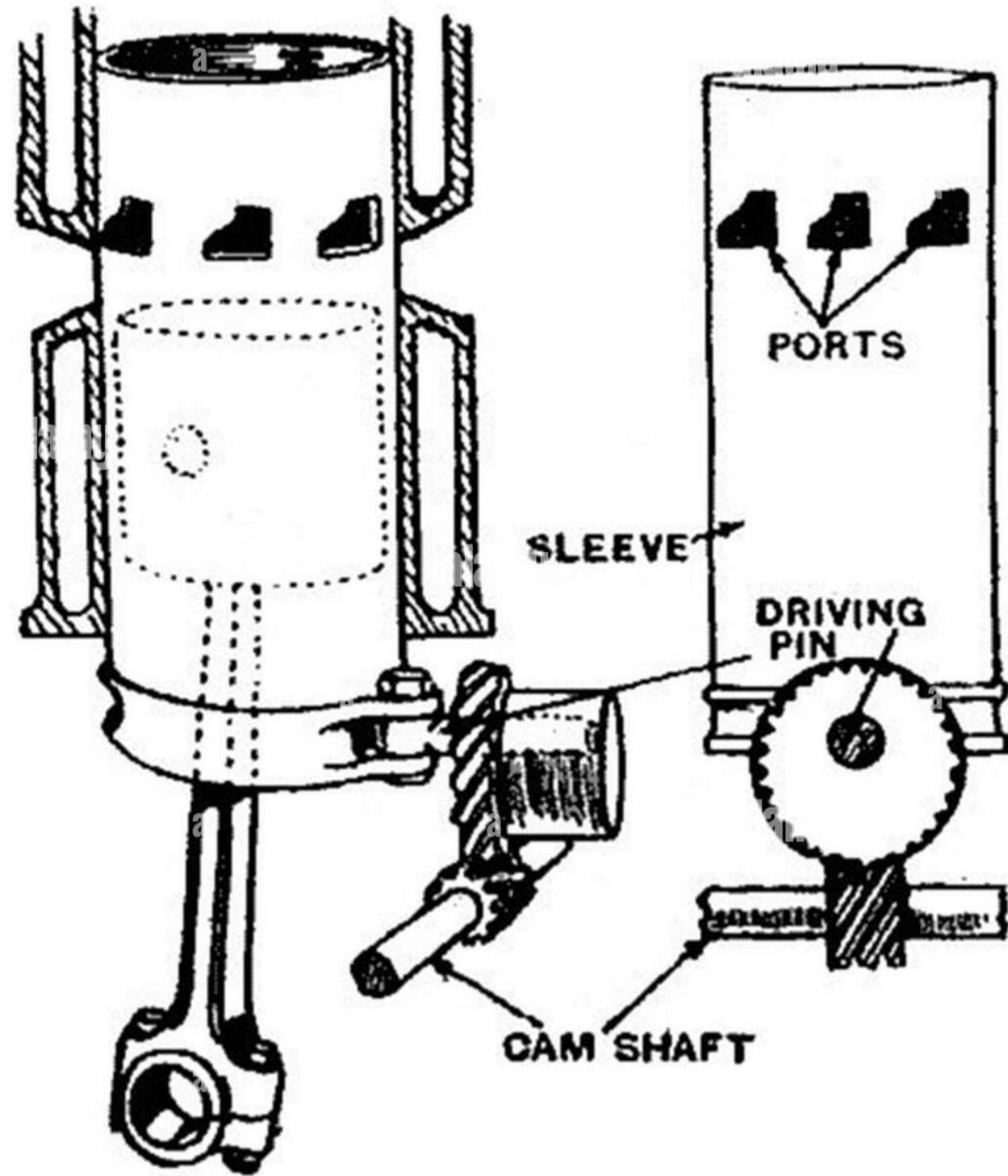



👉 The inner surface of the sleeve forms the inner cylinder barrel in which the piston slides. The sleeve is in continuous motion allowing and driving out the gases by virtue of the periodic coincidence of port cut in the sleeve with ports formed through the main cylinder casting.



Advantages



- 1. These valves are simple in construction and are silent in operation.**
- 2. There is no noise because there are no noise-making parts like valve cams, rocker arm, tappets valves, etc.**
- 3. Sleeve valve has less tendency of detonation. Cooling is very effective as the valve is in contact with water jackets.**



#3 Rotary Valve



👉 There are many types of rotary valves. The figure shows the disc-type rotary valve. It consists of a rotating disc that has a port. While rotating, it communicates alternately with the inlet and exhaust manifolds.



Advantages



- 1. Rotary valves are simple in construction and are manufactured at cheaper costs.**
- 2. They are suitable for high-speed engines.**
- 3. These valves have fewer stresses and vibrations.**
- 4. Rotary valves perform smooth, uniform, and noise-free operations.**



#4 Reed Valve



👉 These are a type of check valve that opens and close the flow of fluid in the same direction under varying pressure on each face. It is consists of a mechanical bar hinged at one end that covers the passage and allows air or charge to flow in only one direction.



👉 This valve is placed such that the suction pressure opens the inlet valve and closes the exhaust valve. And the exhaust pressure closes the inlet valve and opens the exhaust valve. These are usually installed in two-stroke engines.



👉 Reed valve

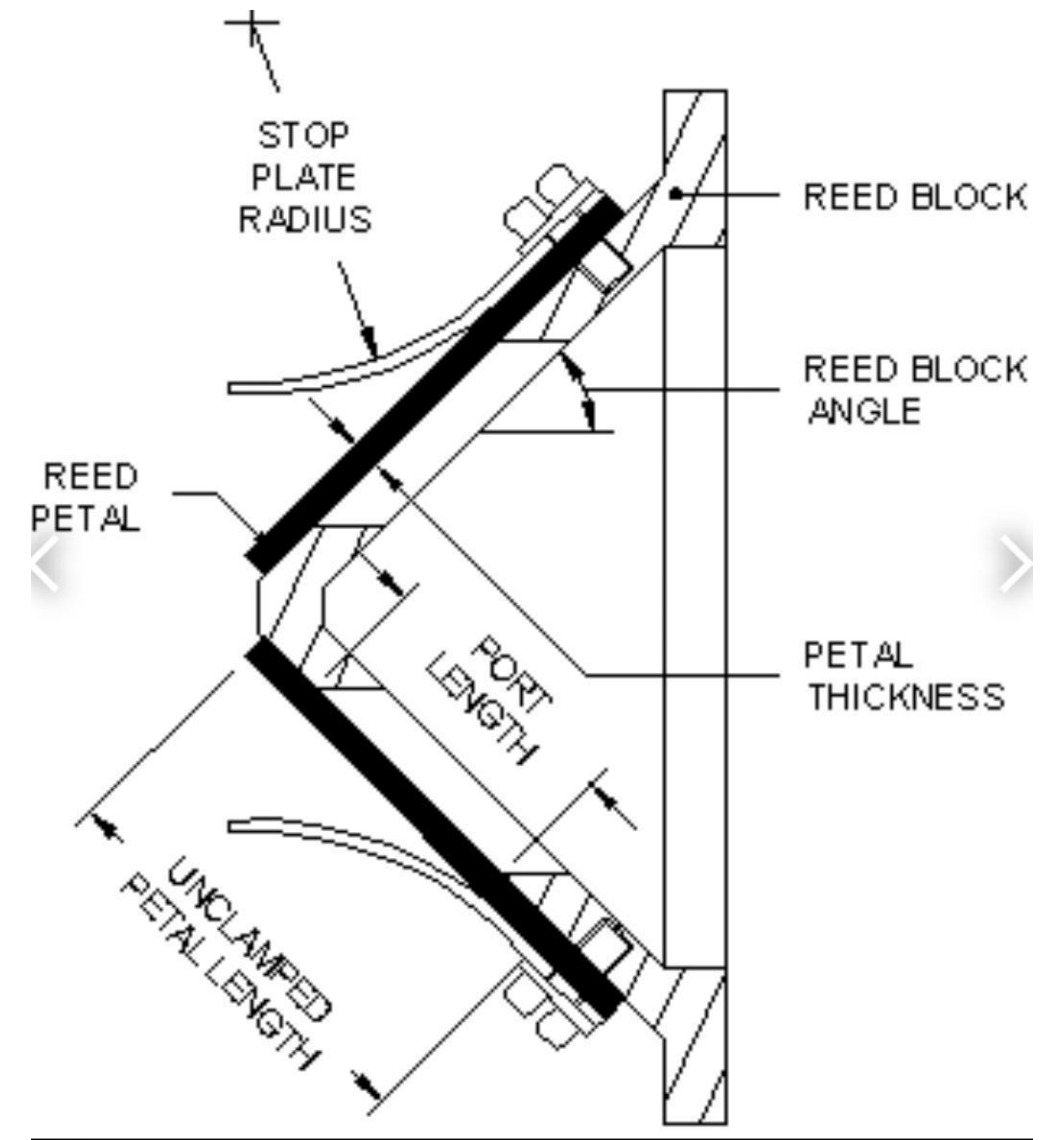



👉 The valves are operated by cams mounted on a camshaft. The camshaft gets motion from the crankshaft. As the camshaft turns, the cam operates the valve.



According to the location of the valves, the valve mechanism is of two types:



👉 Valve mechanism for operating the valve in engine block (straight poppet valve).

👉 Valve mechanism for operating the valve in the cylinder head (overhead poppet valve).



Valve Cooling



 It is obvious that the exhaust valve runs hotter than the inlet valve because the exhaust valve is always in contact with the hot gases while the inlet valve is somewhat cooled by the incoming fresh charge. The exhaust valve may actually become red hot during a short period of operation. The valve face is hottest and the valve stem is the coolest part of a valve.



👉 Temperature of valve

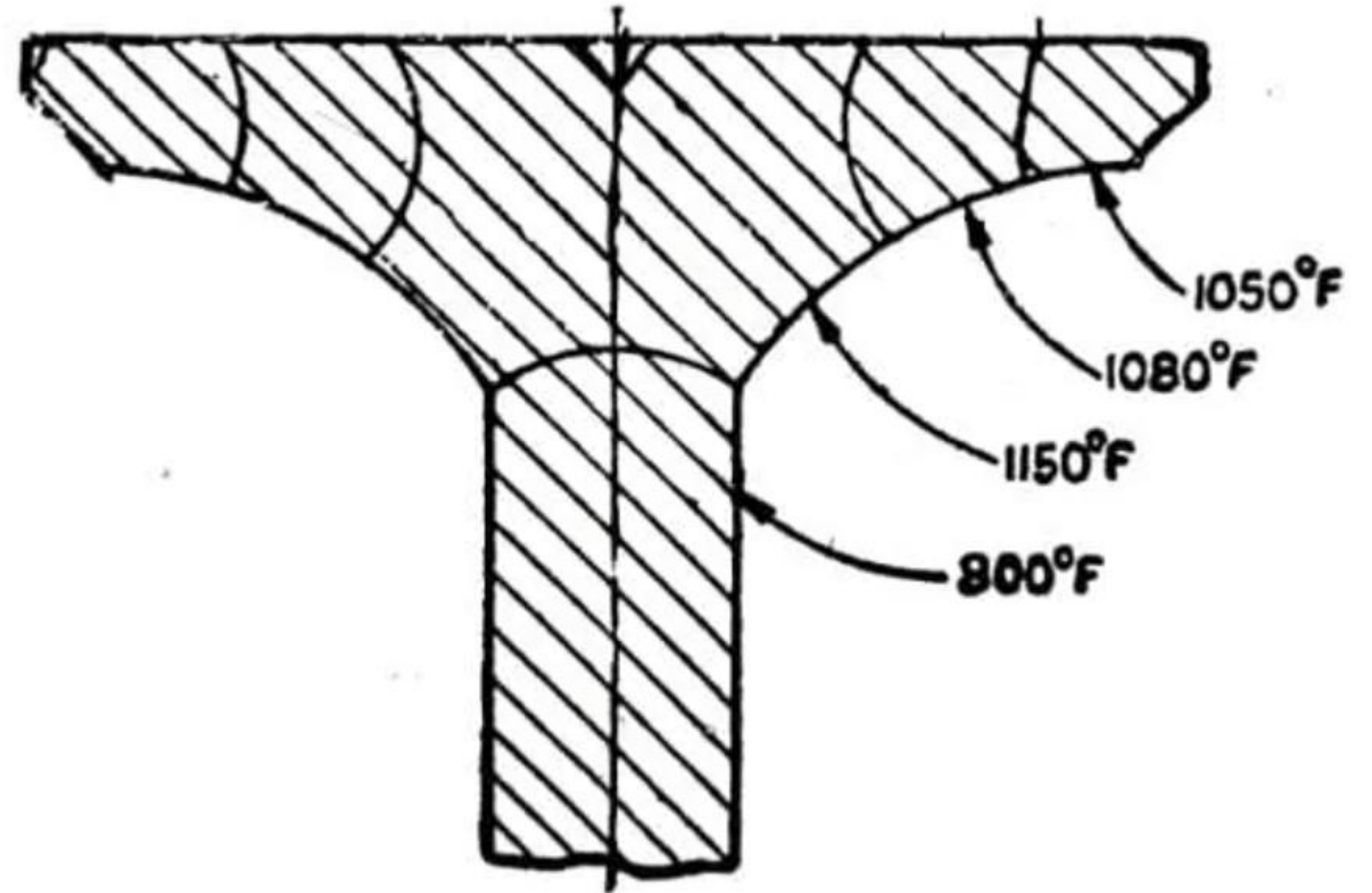



YouTube links

1. <https://youtu.be/8jTM5rPKI6M>

2. <https://youtu.be/fl1Hh0dyL1M>

3. <https://youtu.be/OgSn8GUxCDQ>



Thank You