



# **SNS COLLEGE OF TECHNOLOGY**

**Coimbatore-35**  
**An Autonomous Institution**



Accredited by NBA – AICTE and Accredited by NAAC – UGC with 'A+' Grade  
Approved by AICTE, New Delhi & Affiliated to Anna University, Chennai

## **DEPARTMENT OF ELECTRONICS & COMMUNICATION ENGINEERING**

### **19ECT312 – EMBEDDED SYSTEM DESIGN**

III YEAR/ VI SEMESTER  
1

#### **UNIT 2 :DEVICES AND EMERGING BUS STANDARDS**

#### **TOPIC 2.4 : Communication from serial devices-SPI**



# COMMUNICATION FROM SERIAL DEVICES



## Outline

- Introduction to Serial Buses
- UART
- SPI
- I2C



# COMMUNICATION FROM SERIAL DEVICES



## SPI

### Introduction

- What is it?
- Basic Serial Peripheral Interface (SPI)
- Capabilities
- Protocol
- Pro / Cons and Competitor
- Uses
- Conclusion



# COMMUNICATION FROM SERIAL DEVICES



## SPI

What is SPI?

- Serial Bus protocol
- Fast, Easy to use, Simple
- Everyone supports it

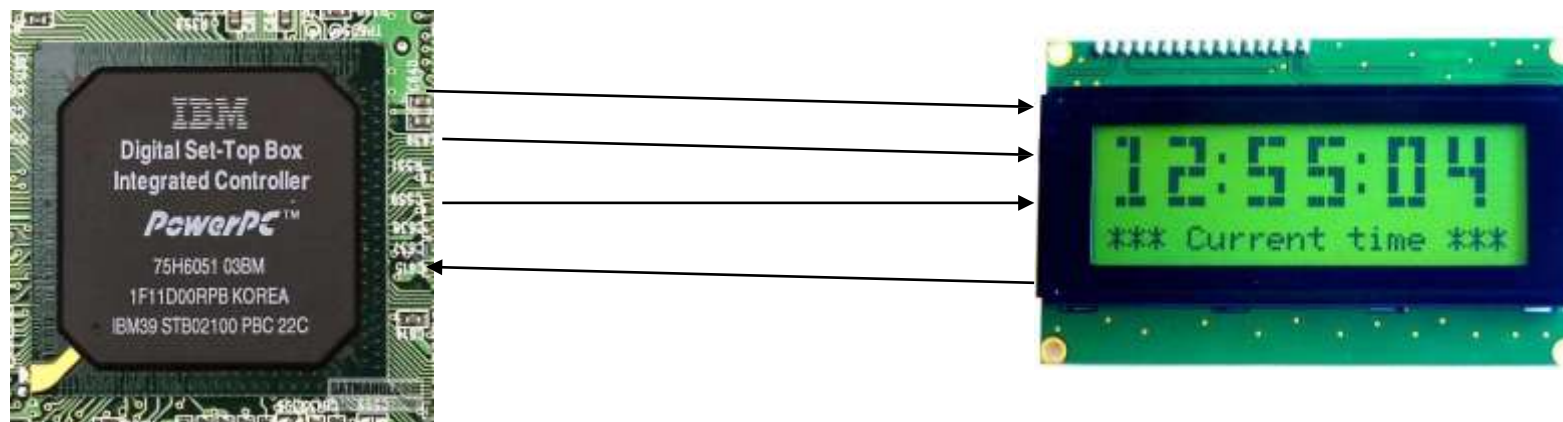



# COMMUNICATION FROM SERIAL DEVICES



## SPI

### SPI Basics

- A communication protocol using 4 wires
  - Also known as a 4 wire bus
- Used to communicate across small distances
- Multiple Slaves, Single Master
- Synchronized



# COMMUNICATION FROM SERIAL DEVICES



## SPI

### Capabilities of SPI

- Always Full Duplex
  - Communicating in two directions at the same time
  - Transmission need not be meaningful
- Multiple Mbps transmission speed
- Transfers data in 4 to 16 bit characters
- Multiple slaves
  - Daisy-chaining possible



# COMMUNICATION FROM SERIAL DEVICES



## SPI

### Protocol

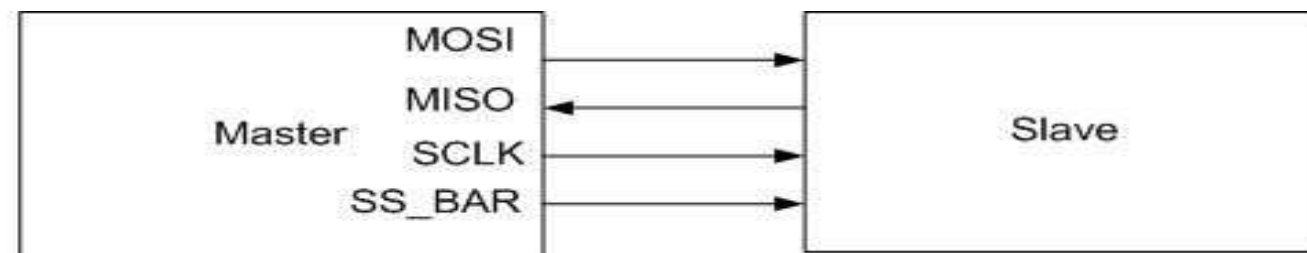

- Wires:
  - Master Out Slave In (MOSI)
  - Master In Slave Out (MISO)
  - System Clock (SCLK)
  - Slave Select 1...N
- Master Set Slave Select low
- Master Generates Clock
- Shift registers shift in and out data



# COMMUNICATION FROM SERIAL DEVICES



## SPI

### Wires in Detail

- MOSI – Carries data out of Master to Slave
- MISO – Carries data from Slave to Master
  - Both signals happen for every transmission
- SS\_BAR – Unique line to select a slave
- SCLK – Master produced clock to synchronize data transfer





# COMMUNICATION FROM SERIAL DEVICES



## SPI

### Shifting Protocol

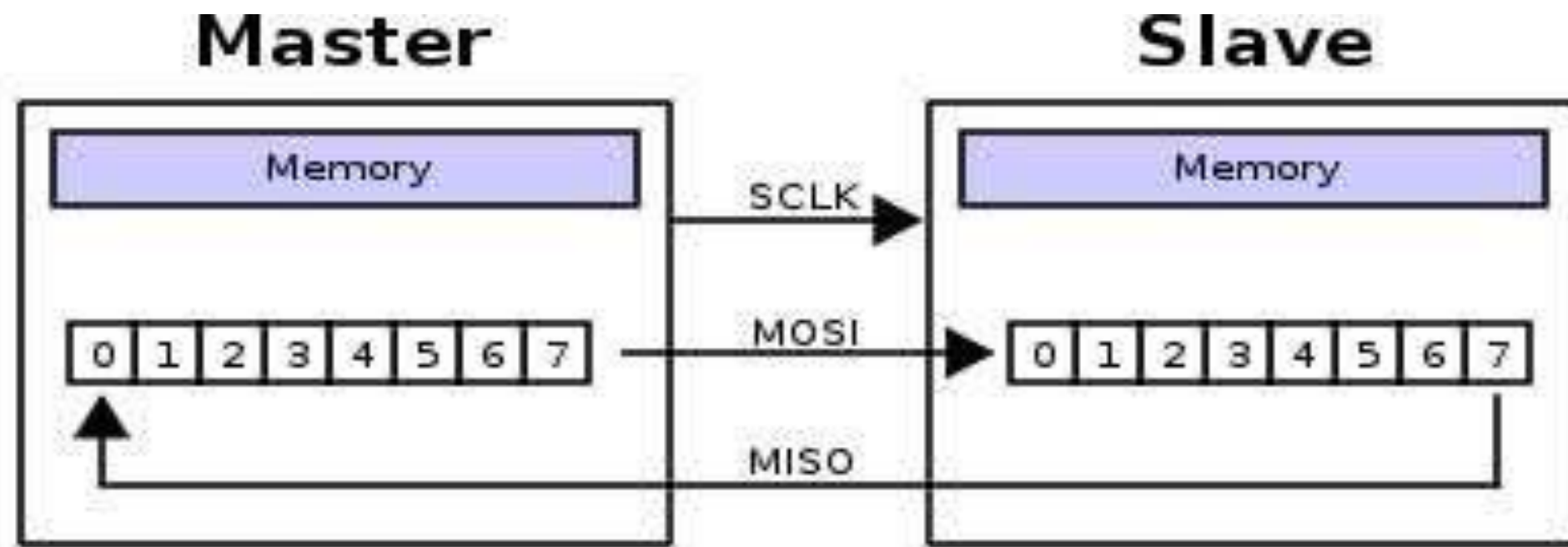

Master shifts out data to Slave, and shift in data from Slave

[http://upload.wikimedia.org/wikipedia/commons/thumb/b/bb/SPI\\_8-bit\\_circular\\_transfer.svg/400px-SPI\\_8-bit\\_circular\\_transfer.svg.png](http://upload.wikimedia.org/wikipedia/commons/thumb/b/bb/SPI_8-bit_circular_transfer.svg/400px-SPI_8-bit_circular_transfer.svg.png)



# COMMUNICATION FROM SERIAL DEVICES



## SPI

### Diagram

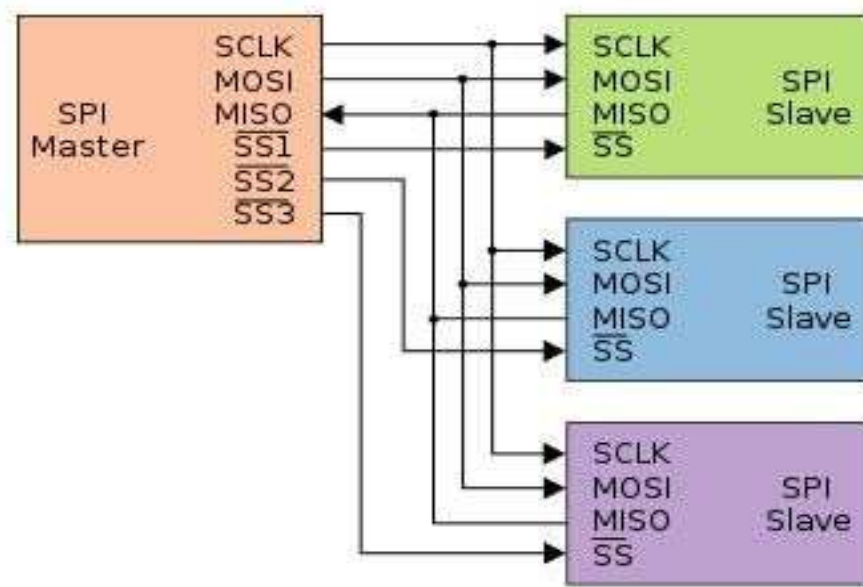
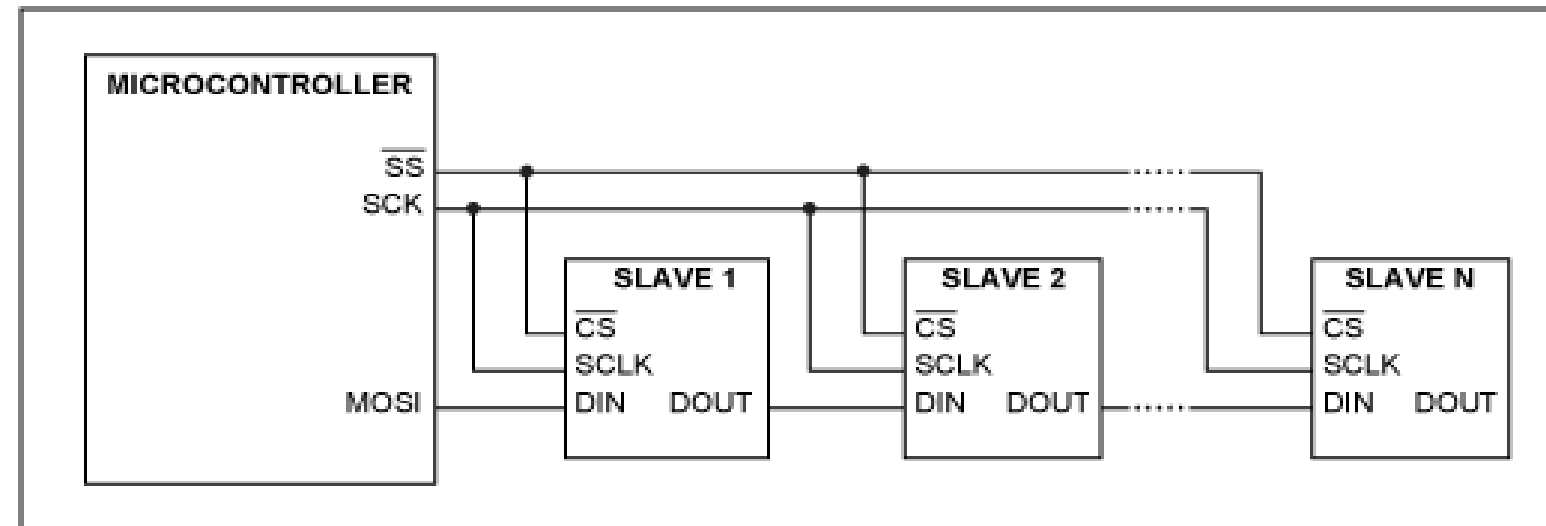

Some wires have been renamed

Master and multiple daisy-chained slaves

[http://www.maxim-ic.com/appnotes.cfm/an\\_pk/3947](http://www.maxim-ic.com/appnotes.cfm/an_pk/3947)

Master and multiple independent slaves

[http://upload.wikimedia.org/wikipedia/commons/thumb/f/fc/SPI\\_three\\_slaves.svg/350px-SPI\\_three\\_slaves.svg.png](http://upload.wikimedia.org/wikipedia/commons/thumb/f/fc/SPI_three_slaves.svg/350px-SPI_three_slaves.svg.png)



# COMMUNICATION FROM SERIAL DEVICES



## SPI

### Clock Phase (Advanced)

- Two phases and two polarities of clock
- Four modes
- Master and selected slave must be in same mode
- Master must change polarity and phase to communicate with slaves of different numbers



# COMMUNICATION FROM SERIAL DEVICES



## SPI

### Timing Diagram

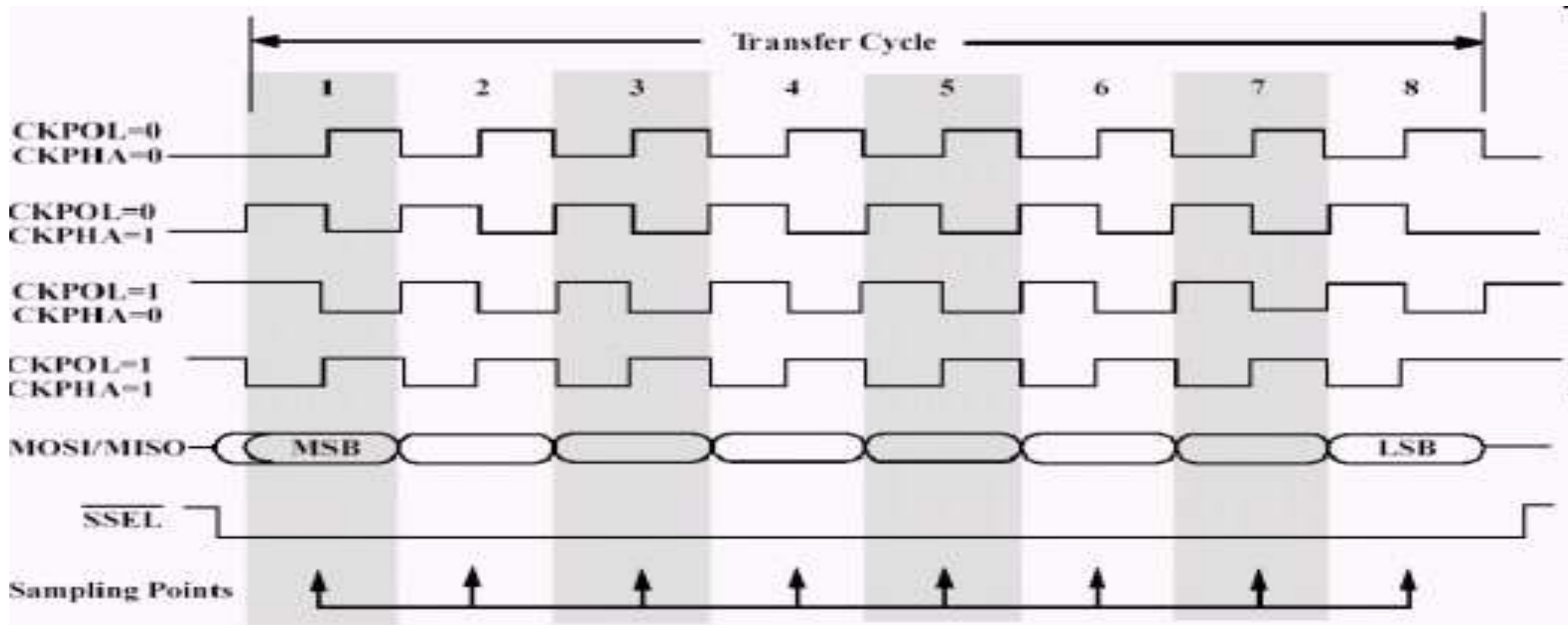

Timing Diagram – Showing Clock polarities and phases

<http://www.maxim-ic.com.cn/images/appnotes/3078/3078Fig02.gif>



# COMMUNICATION FROM SERIAL DEVICES



## SPI

### Pros and Cons

#### Pros:

- Fast and easy
  - Fast for point-to-point connections
  - Easily allows streaming/Constant data inflow
  - No addressing/Simple to implement
- Everyone supports it

#### Cons:

- SS makes multiple slaves very complicated
- No acknowledgement ability
- No inherent arbitration
- No flow control

### Uses

- Some Serial Encoders/Decoders, Converters, Serial LCDs, Sensors, etc.
- Pre-SPI serial devices



# COMMUNICATION FROM SERIAL DEVICES



## SPI

### Summary

- SPI – 4 wire serial bus protocol
  - MOSI MISO SS SCLK wires
- Full duplex
- Multiple slaves, One master
- Best for point-to-point streaming data
- Easily Supported



# SUMMARY & THANK YOU