



SNS COLLEGE OF TECHNOLOGY

Coimbatore-35
An Autonomous Institution



Accredited by NBA – AICTE and Accredited by NAAC – UGC with 'A+' Grade
Approved by AICTE, New Delhi & Affiliated to Anna University, Chennai

DEPARTMENT OF ELECTRONICS & COMMUNICATION ENGINEERING

OPTICAL AND MICROWAVE ENGINEERING

III YEAR/ VI SEMESTER

19ECB311 –OPTICAL AND MICROWAVE
ENGINEERING /E.CHRISTINA DALLY /AP
ECE/SNSCT

UNIT 3 – MICROWAVE MEASUREMENTS

TOPIC– MICROWAVE POWER MEASUREMENT



Guess the Topic????





LOW POWER MEASUREMENT



The measurement of Microwave power around 0.01mW to 10mW, can be understood as the measurement of low power.

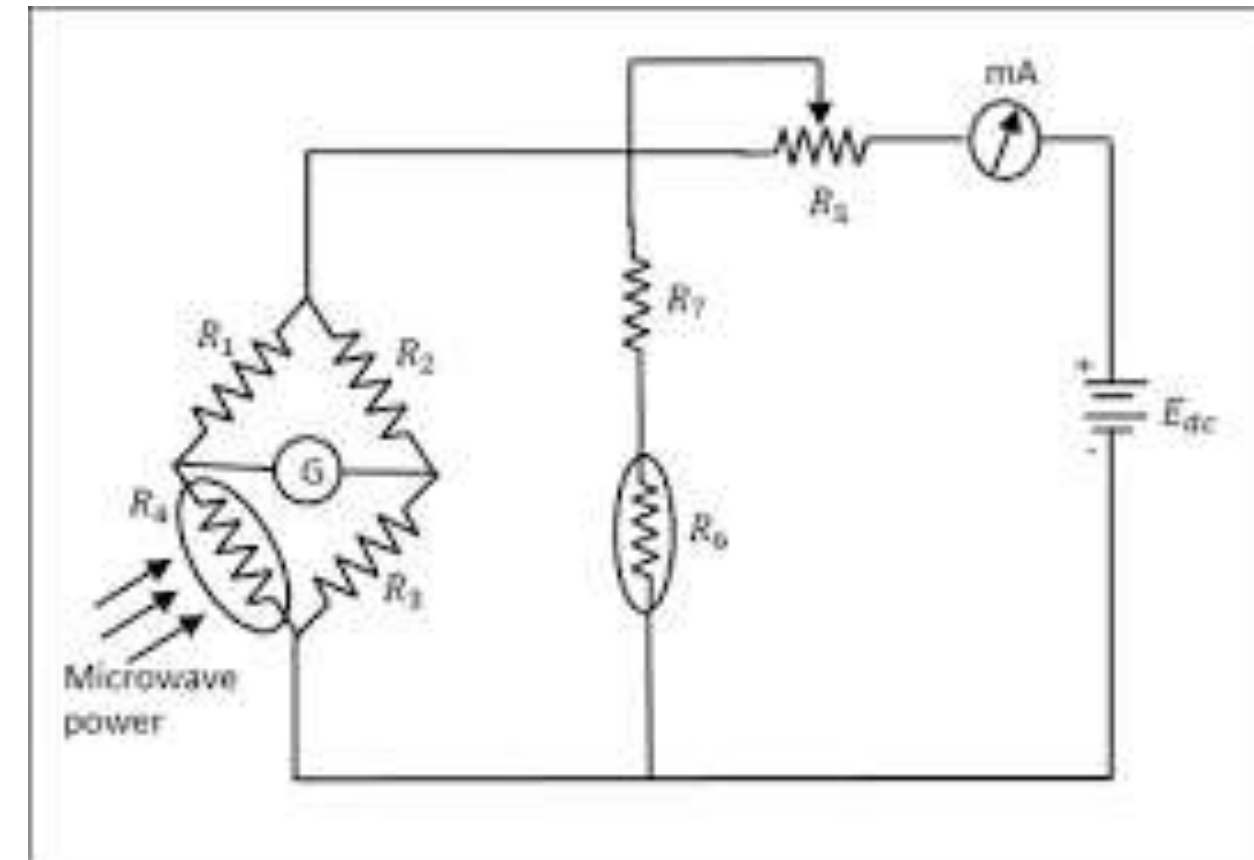



BOLOMETER

- Bolometer is a device which is used for low Microwave power measurements.
- The element used in bolometer could be of positive or negative temperature coefficient.
- For example, a barrater has a positive temperature coefficient whose resistance increases with the increase in temperature

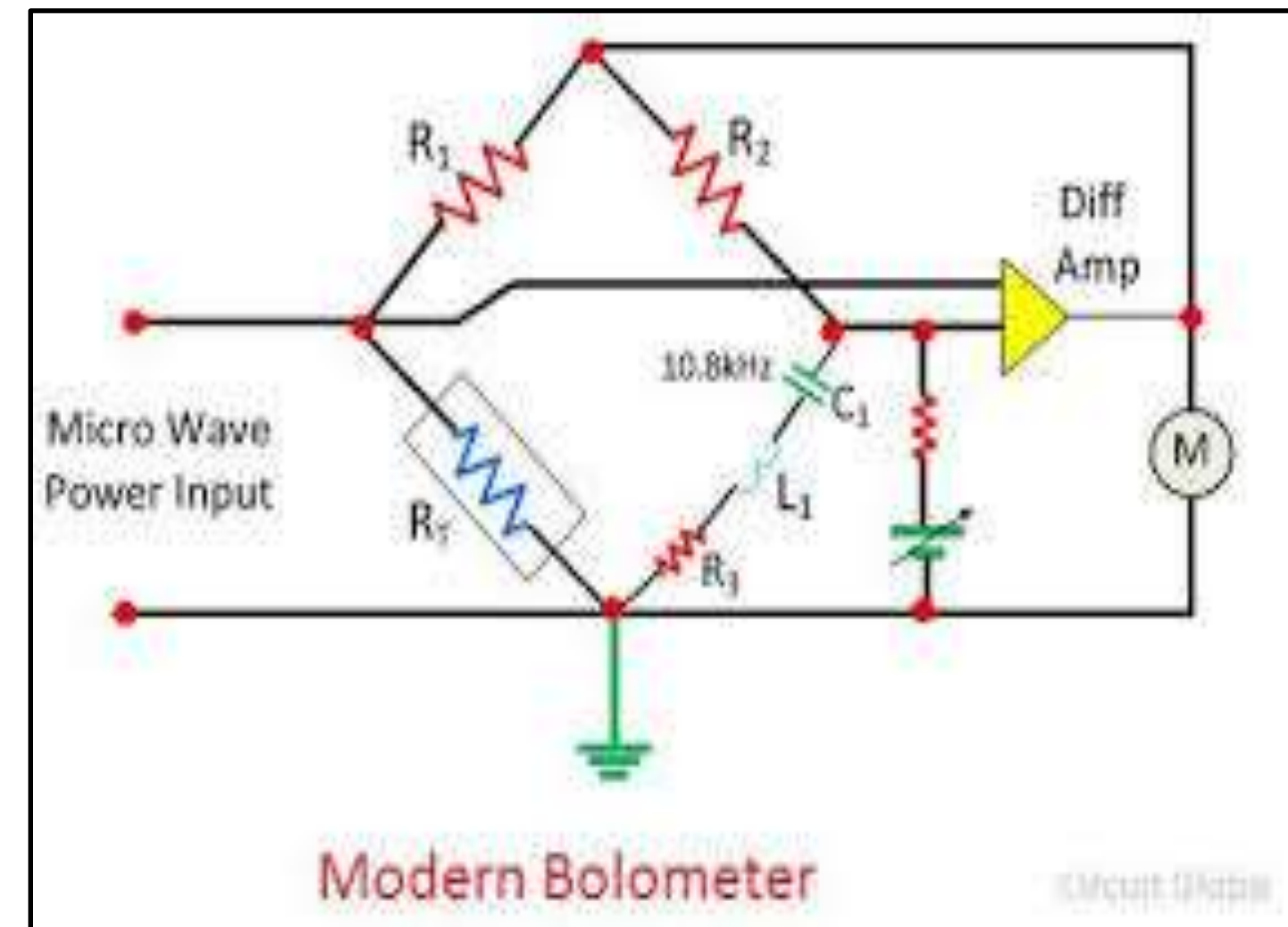



BOLOMETER



Any of them can be used in the bolometer, but the change in resistance is proportional to Microwave power applied for measurement. This bolometer is used in a bridge of the arms as one so that any imbalance caused, affects the output.

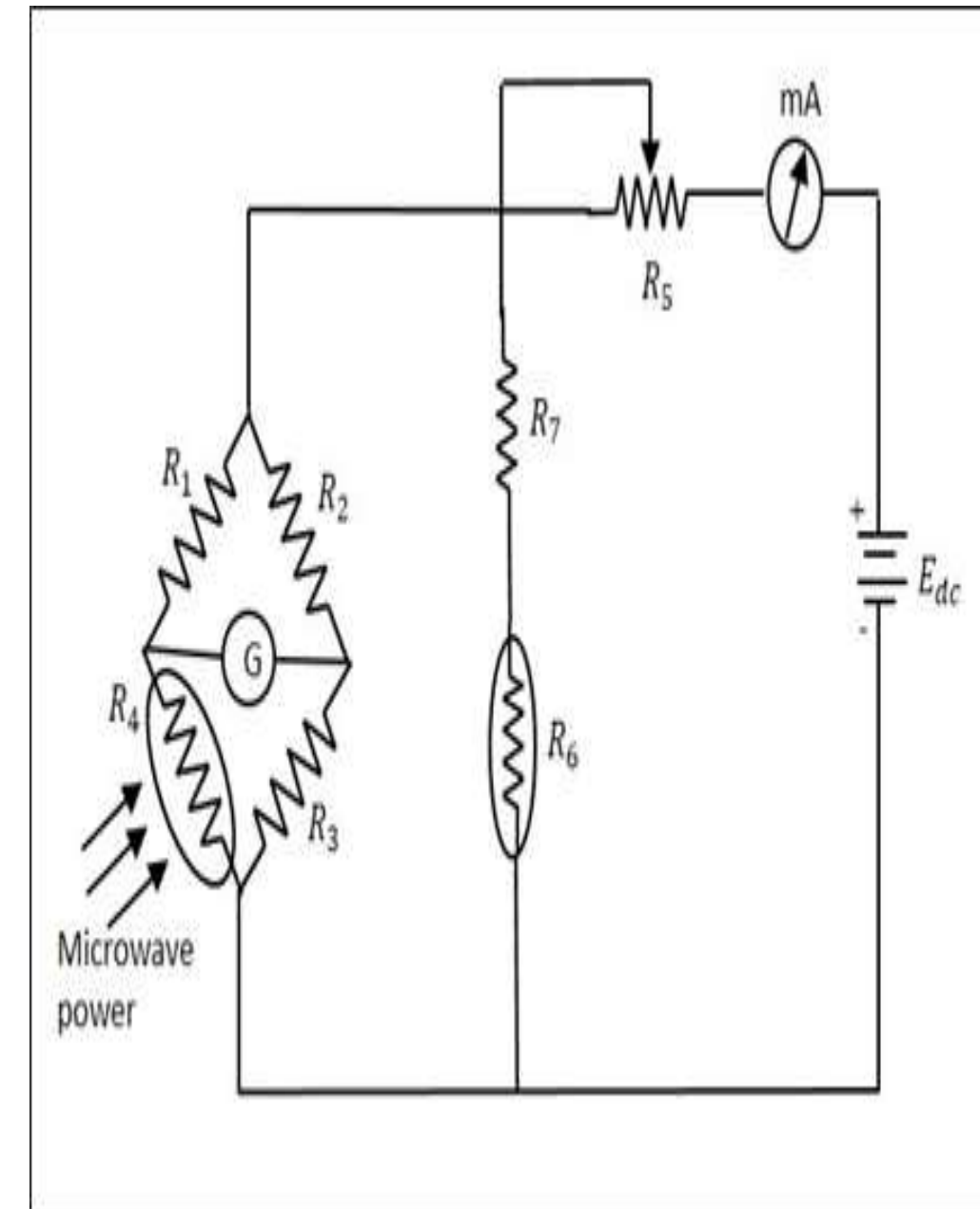



CALORIMETRIC METHOD



The measurement of Microwave power around 10mW to 1W, can be understood as the measurement of medium power.

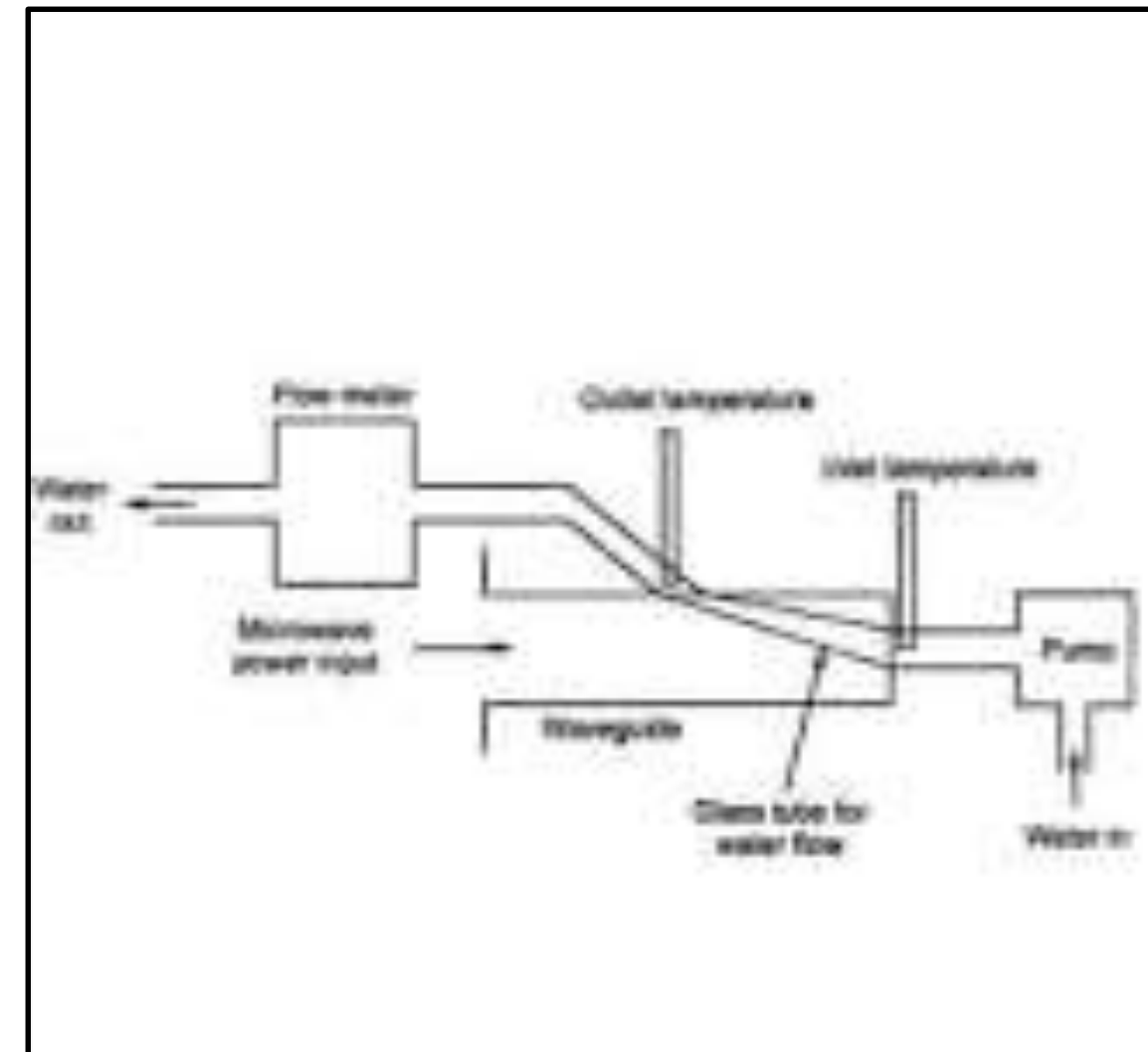



ACTIVITY TME



$$\begin{array}{r} \square + \square = 14 \\ + \\ \square - \square = 10 \\ \parallel \quad \parallel \\ 15 \quad 16 \end{array}$$



MICROWAVE POWER MEASUREMENTS



- > The measurement of Microwave power around 10W to 50KW, can be understood as the measurement of high power.
- >The change in temperature of the liquid before and after entering the load, is taken for the calibration of values.
- >The limitations in this method are like flow determination, calibration and thermal inertia, etc.

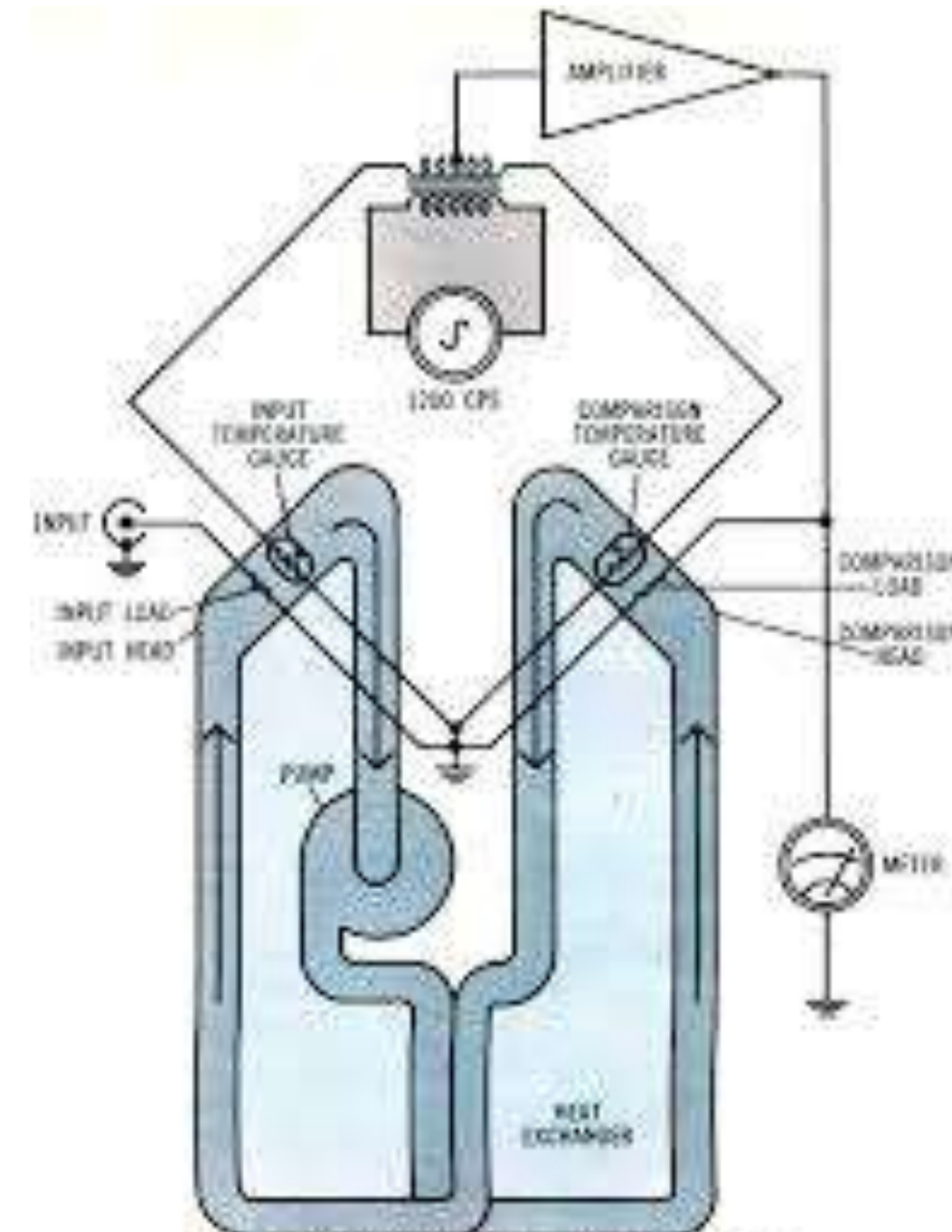
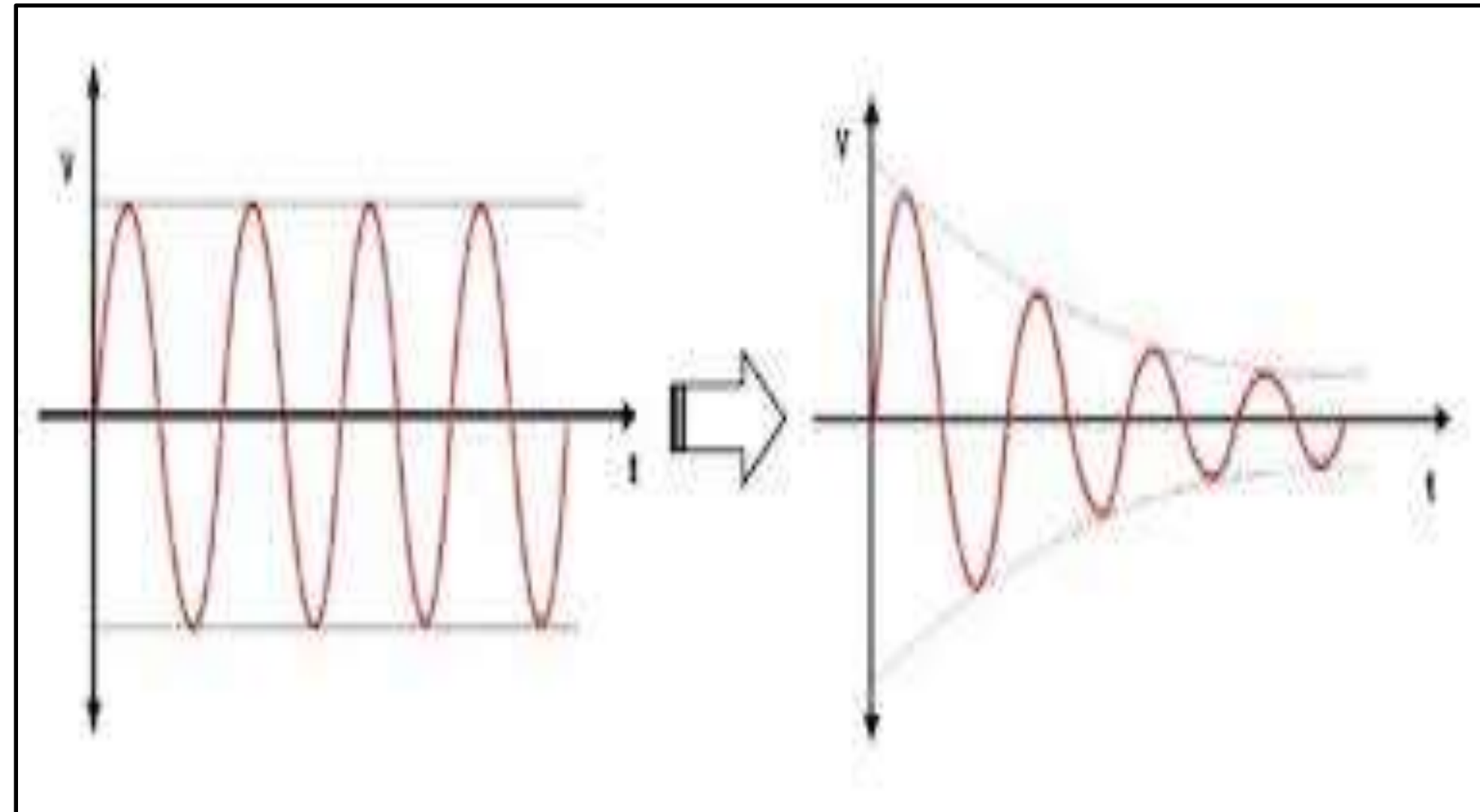

Fig. 1. Simplified diagram of a calorimetric power meter.



GUESS THE TOPIC????



3/20/2023



ATTENUATION MEASUREMENT



Microwave components and devices often provide some attenuation. The amount of attenuation offered can be measured in two ways. They are – Power ratio method and RF substitution method.

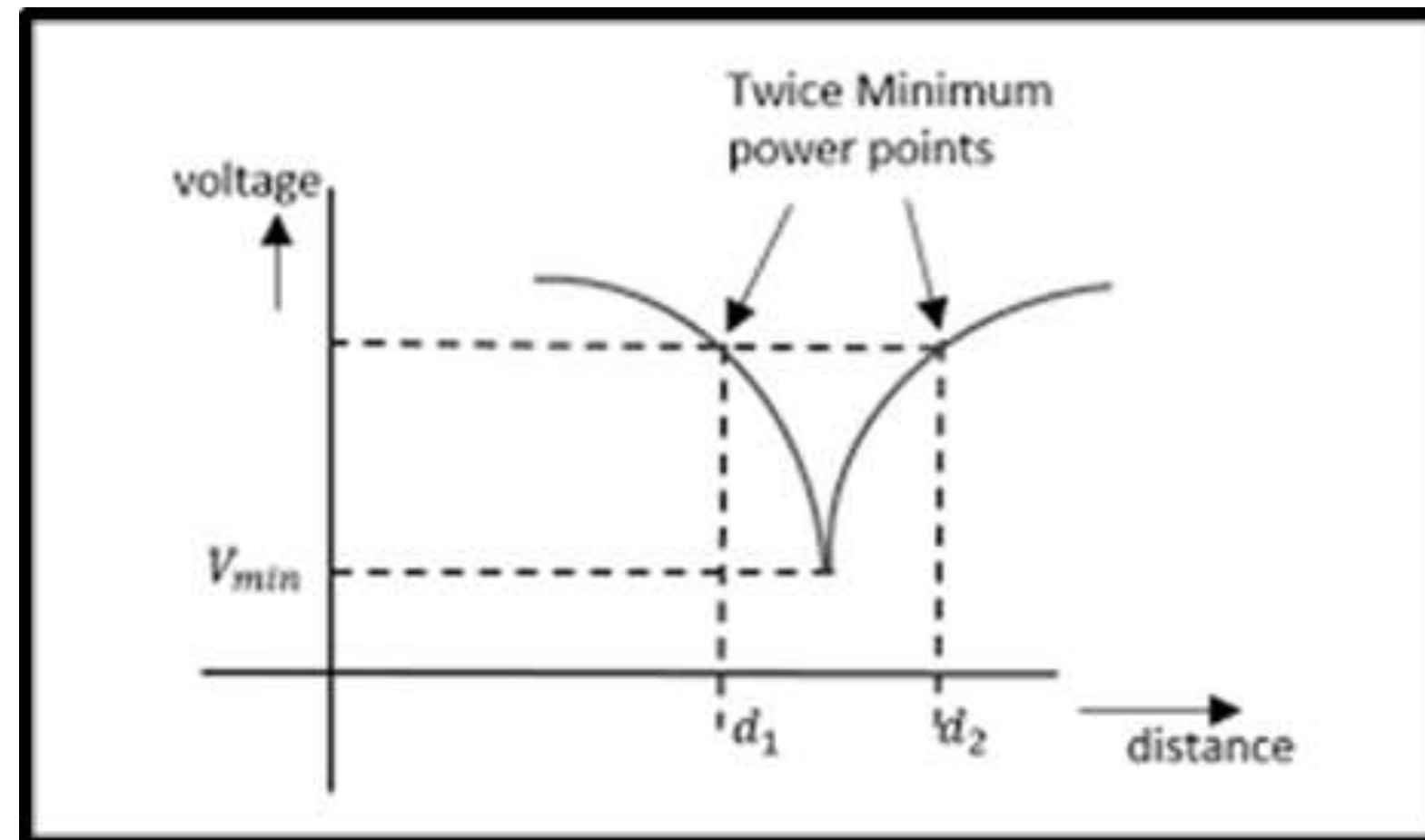

3/20/2023



ATTENUATION MEASUREMENT



Attenuation is the ratio of input power to the output power and is normally expressed in decibels.

$$\text{Attenuation in dBs} = 10 \log \frac{P_{in}}{P_{out}}$$

Where P_{in} = Input power and P_{out} = Output power

3/20/2023



ATTENUATION MEASUREMENT



Power Ratio Method

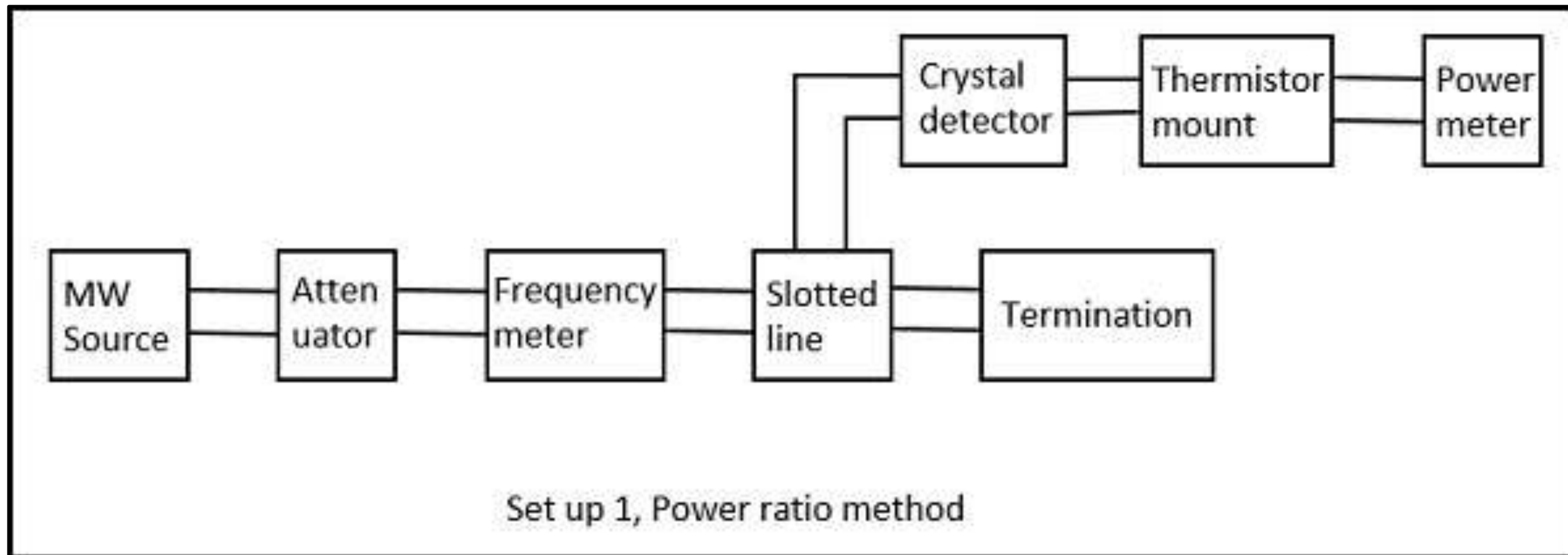

3/20/2023



POWER RATIO METHOD

The input and output power of the whole Microwave bench is done with the device whose attenuation has to be calculated.

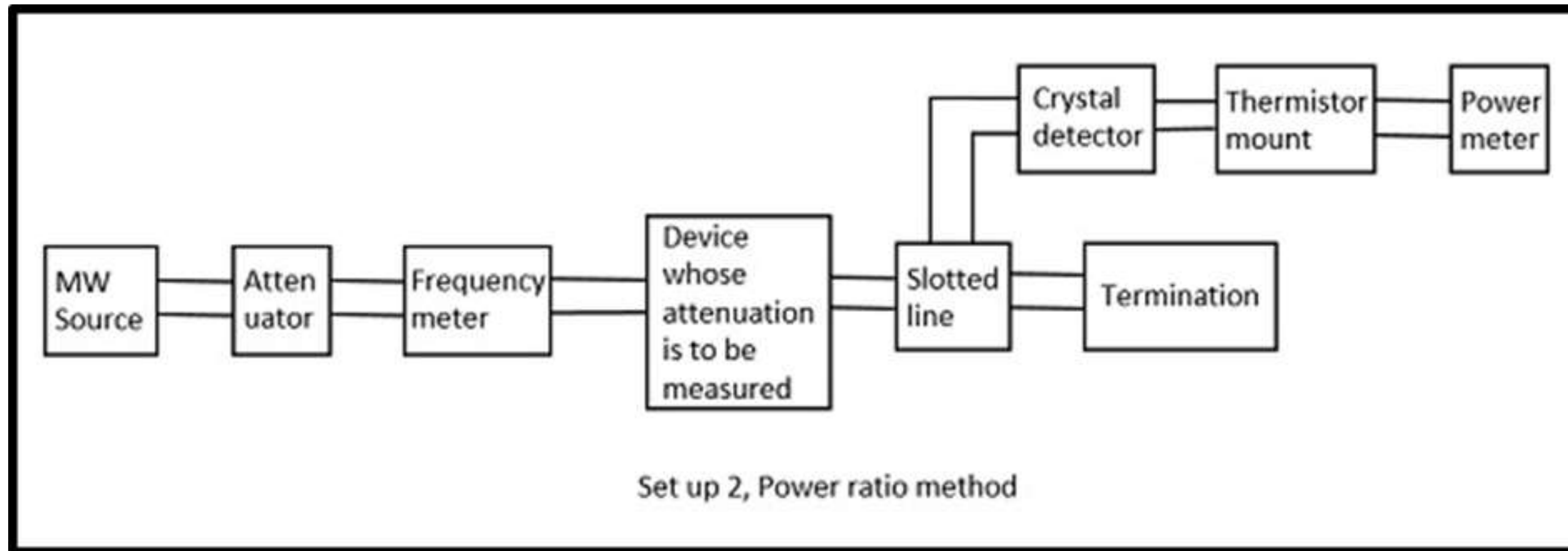

3/20/2023



MEASUREMENT OF PHASE SHIFT



To measure such phase shift, we use a comparison technique, by which we can calibrate the phase shift.

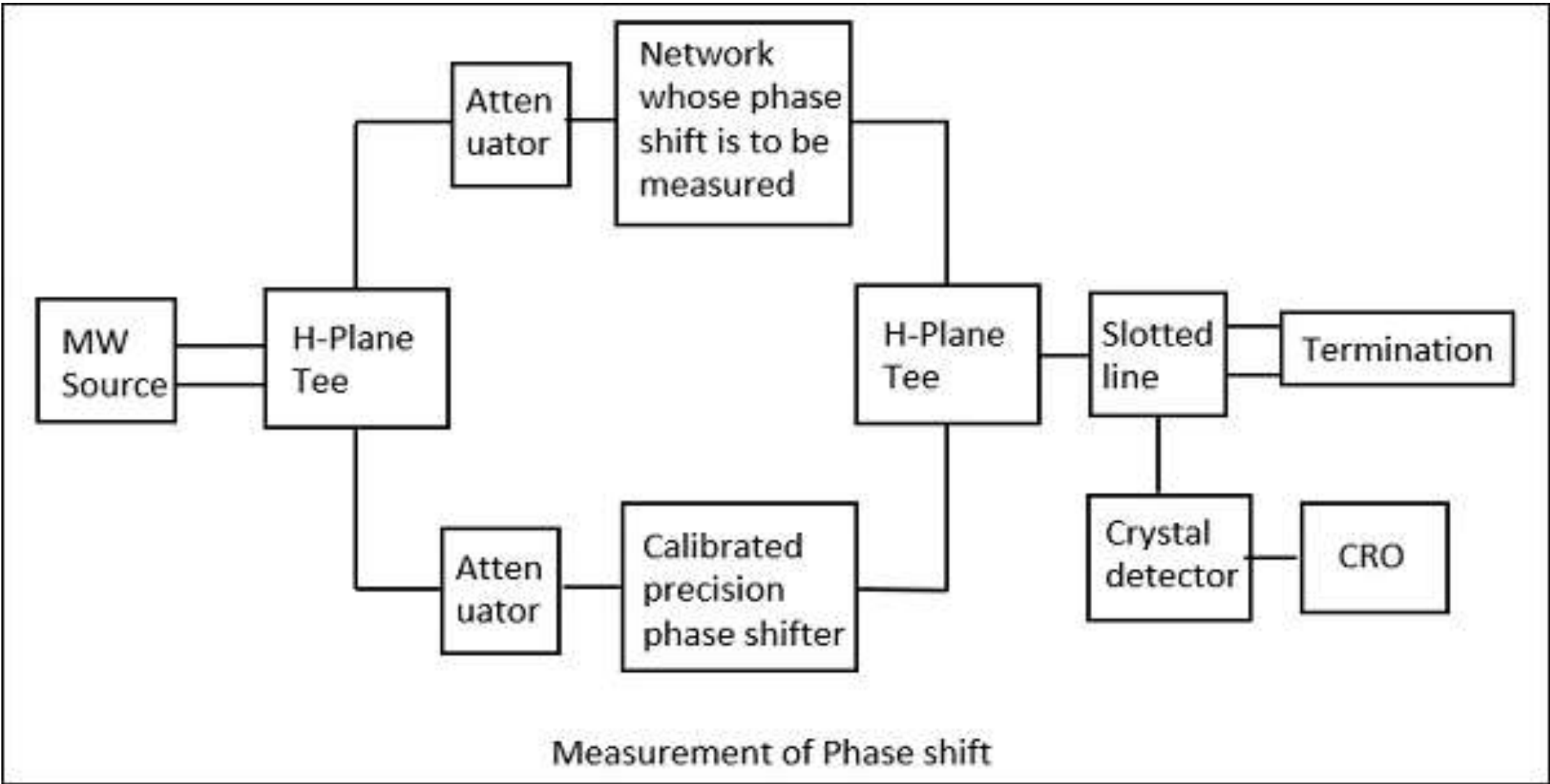

3/20/2023



ASSESSMENT TIME



Think, Pair, Share

What's the issue / question / topic?	What do I think about it?	What does my partner think?	What will we share?
			



THANK YOU