

## UNIT-1 CONDUCTION

### PART-A

#### 1. State Fourier's Law of conduction. [NOV-DEC 13] [NOV-DEC 14]

The rate of heat conduction is proportional to the area measured – normal to the direction of heat flow and to the temperature gradient in that direction.

$$Q \propto -A \frac{dT}{dx} \quad Q = -KA \frac{dT}{dx} \quad \text{where } A - \text{are in } m^2$$

$$\frac{dT}{dx} - \text{Temperature gradient in K/m} \quad K - \text{Thermal conductivity W/mK.}$$

#### 2. Define Thermal Conductivity.

Thermal conductivity is defined as the ability of a substance to conduct heat.

#### 3. Write down the equation for conduction of heat through a slab or plane wall.

$$\text{Heat transfer } Q = \frac{\Delta T_{\text{overall}}}{R} \quad \text{Where} \quad \Delta T = T_1 - T_2$$

$$R = \frac{L}{KA} - \text{Thermal resistance of slab}$$

$$L = \text{Thickness of slab,} \quad K = \text{Thermal conductivity of slab,} \quad A = \text{Area}$$

#### 4. Write down the equation for conduction of heat through a hollow cylinder.

$$\text{Heat transfer } Q = \frac{\Delta T_{\text{overall}}}{R} \quad \text{Where, } \Delta T = T_1 - T_2$$

$$R = \frac{1}{2\pi LK} \ln \left[ \frac{r_2}{r_1} \right] \text{ thermal resistance of slab}$$

$$L - \text{Length of cylinder, } K - \text{Thermal conductivity, } r_2 - \text{Outer radius, } r_1 - \text{inner radius}$$

#### 5. State Newton's law of cooling or convection law.

Heat transfer by convection is given by Newton's law of cooling

$$Q = hA (T_s - T_\infty)$$

Where

$$A - \text{Area exposed to heat transfer in } m^2, \quad h - \text{heat transfer coefficient in } W/m^2K$$

$$T_s - \text{Temperature of the surface in K,} \quad T_\infty - \text{Temperature of the fluid in K.}$$

#### 6. Write down the general equation for one dimensional steady state heat transfer in slab or plane wall with and without heat generation.

$$\frac{\partial^2 T}{\partial x^2} + \frac{\partial^2 T}{\partial y^2} + \frac{\partial^2 T}{\partial z^2} = \frac{1}{\alpha} \frac{\partial T}{\partial t} \quad \frac{\partial^2 T}{\partial x^2} + \frac{\partial^2 T}{\partial y^2} + \frac{\partial^2 T}{\partial z^2} + \frac{q}{K} = \frac{1}{\alpha} \frac{\partial T}{\partial t}$$

#### 7. Define overall heat transfer co-efficient.

The overall heat transfer by combined modes is usually expressed in terms of an overall conductance or overall heat transfer co-efficient 'U'.

$$\text{Heat transfer } Q = UA \Delta T.$$

#### 8. Write down the equation for heat transfer through composite pipes or cylinder.

$$\text{Heat transfer } Q = \frac{\Delta T_{\text{overall}}}{R}, \quad \text{Where, } \Delta T = T_a - T_b, \quad R = \frac{1}{2\pi L} \left[ \frac{1}{h_a r_1} + \frac{\ln \left[ \frac{r_2}{r_1} \right]}{K_1} + \frac{\ln \left[ \frac{r_1}{r_2} \right]}{K_2} + \frac{1}{h_b r_3} \right]$$

#### 9. Define critical thickness of insulation with its significance. [MAY-JUN 14]

Addition of insulating material on a surface does not reduce the amount of heat transfer rate always. In fact under certain circumstances it actually increases the heat loss up to certain thickness of

insulation. The radius of insulation for which the heat transfer is maximum is called critical radius of insulation, and the corresponding thickness is called critical thickness.

For cylinder, Critical radius =  $r_c = k/h$ ,

Where k- Thermal conductivity of insulating material,

h- heat transfer coefficient of surrounding fluid.

Significance: electric wire insulation may be smaller than critical radius. Therefore the plastic insulation may actually enhance the heat transfer from wires and thus keep their steady operating temperature at safer levels.

**10. Define fins (or) extended surfaces.**

It is possible to increase the heat transfer rate by increasing the surface of heat transfer. The surfaces used for increasing heat transfer are called extended surfaces(fins).

**11. State the applications of fins.**

The main applications of fins are

1. Cooling of electronic components
2. Cooling of motor cycle engines.
3. Cooling of transformers
4. Cooling of small capacity compressors

**12. Define Fin efficiency.**

The efficiency of a fin is defined as the ratio of actual heat transfer by the fin to the maximum possible heat transferred by the fin.

$$\eta_{fin} = \frac{Q_{fin}}{Q_{max}}$$

**13. Define Fin effectiveness.**

Fin effectiveness is the ratio of heat transfer with fin to that without fin

$$\text{Fin effectiveness} = \frac{Q_{with\ fin}}{Q_{without\ fin}}$$

**14. Write any two examples of heat conduction with heat generation. [MAY JUN 14]**

- i) Resistance heater wires - resistance heating in wires is conversion of electrical energy to heat and heat energy is conducted along the wire
- ii) A nuclear fuel rod - Heat is generated in rod and conducted along it

**15. How does transient heat transfer differ from steady heat transfer?**

The term steady implies no change with time at any point within the medium while transient implies variation with time or time dependence. Therefore, the temperature or heat flux remains unchanged with time during steady heat transfer through a medium at any location although both quantities may vary from one location to another. During transient heat transfer, the temperature and heat flux may vary with time as well as location.

**16. What is heat generation in a solid?**

In heat conduction analysis, the conversion of electrical, chemical, or nuclear energy into heat (or thermal) energy in solids is called heat generation.

**17. Write down the one-dimensional transient heat conduction equation for a plane wall with constant thermal conductivity and heat generation in its simplest form, and indicate what each variable represents.**

The one-dimensional transient heat conduction equation for a plane wall with constant thermal conductivity and heat generation is

$$\frac{\partial^2 T}{\partial x^2} + \frac{e_{gen}}{k} = \frac{1}{\alpha} \frac{\partial T}{\partial t}$$

Here T is the temperature, x is the space variable,  $e_{gen}$  is the heat generation per unit volume, k is the thermal conductivity,  $\alpha$  is the thermal diffusivity, and t is the time.

- 18. Consider one-dimensional heat conduction through a cylindrical rod of diameter D and length L. What is the heat transfer area of the rod if (a) the lateral surfaces of the rod are insulated and (b) the top and bottom surfaces of the rod are insulated?**

If the lateral surfaces of the rod are insulated, the heat transfer surface area of the cylindrical rod is the bottom or the top surface area of the rod,  $A_s = \frac{\pi D^2}{4}$

If the top and the bottom surfaces of the rod are insulated, the heat transfer area of the rod is the lateral surface area of the rod,  $A = \pi DL$

- 19. What does the thermal resistance of a medium represent? and Why are the convection and the radiation resistances at a surface in parallel instead of being in series?**

The thermal resistance of a medium represents the resistance of that medium against heat transfer. The convection and the radiation resistances at a surface are parallel since both the convection and radiation heat transfers occur simultaneously.

- 20. What is the difference between the fin effectiveness and the fin efficiency? The fins attached to a surface are determined to have an effectiveness of 0.9. Do you think the rate of heat transfer from the surface has increased or decreased as a result of the addition of these fins?**

The fin efficiency is defined as the ratio of actual heat transfer rate from the fin to the ideal heat transfer rate from the fin if the entire fin were at base temperature, and its value is between 0 and 1. Fin effectiveness is defined as the ratio of heat transfer rate from a finned surface to the heat transfer rate from the same surface if there were no fins, and its value is expected to be greater than 1. Heat transfer rate will decrease since a fin effectiveness smaller than 1 indicates that the fin acts as insulation.

- 21. What is lumped system analysis? When is it applicable? [NOV-DEC 14]**

In heat transfer analysis, some bodies are observed to behave like a "lump" whose entire body temperature remains essentially uniform at all times during a heat transfer process. The temperature of such bodies can be taken to be a function of time only. Heat transfer analysis which utilizes this idealization is known as the lumped system analysis. It is applicable when the Biot number (the ratio of conduction resistance within the body to convection resistance at the surface of the body) is less than or equal to 0.1.

- 22. What is the physical significance of the Biot number? Is the Biot number more likely to be larger for highly conducting solids or poorly conducting ones?**

Biot number represents the ratio of conduction resistance within the body to convection resistance at the surface of the body. The Biot number is more likely to be larger for poorly conducting solids since such bodies have larger resistances against heat conduction.

- 23. In what medium is the lumped system analysis more likely to be applicable: in water or in air? why?**

The lumped system analysis is more likely to be applicable in air than in water since the convection heat transfer coefficient and thus the Biot number is much smaller in air.

- 24. What is a semi-infinite medium? Give examples of solid bodies that can be treated as semi-infinite mediums for heat transfer purposes.**

A semi-infinite medium is an idealized body which has a single exposed plane surface and extends to infinity in all directions. The earth and thick walls can be considered to be semi-infinite media.

## PART B

1. A wall is constructed of several layers. The first layer consists of masonry brick 20 cm. thick of thermal conductivity 0.66 W/mK, the second layer consists of 3 cm thick mortar of thermal conductivity 0.6 W/mK, the third layer consists of 8 cm thick lime stone of thermal conductivity 0.58 W/mK and the outer layer consists of 1.2 cm thick plaster of thermal conductivity 0.6 W/mK. The heat transfer coefficient on the interior and exterior of the wall are 5.6 W/m<sup>2</sup>K and 11 W/m<sup>2</sup>K respectively. Interior room temperature is 22°C and outside air temperature is -5°C. Calculate
- Overall heat transfer coefficient
  - Overall thermal resistance
  - The rate of heat transfer
  - The temperature at the junction between the mortar and the limestone.

### Given Data

Thickness of masonry  $L_1 = 20\text{cm} = 0.20\text{ m}$

Thermal conductivity  $K_1 = 0.66\text{ W/mK}$

Thickness of mortar  $L_2 = 3\text{cm} = 0.03\text{ m}$

Thermal conductivity of mortar  $K_2 = 0.6\text{ W/mK}$

Thickness of limestone  $L_3 = 8\text{ cm} = 0.08\text{ m}$

Thermal conductivity  $K_3 = 0.58\text{ W/mK}$

Thickness of Plaster  $L_4 = 1.2\text{ cm} = 0.012\text{ m}$

Thermal conductivity  $K_4 = 0.6\text{ W/mK}$

Interior heat transfer coefficient  $h_a = 5.6\text{ W/m}^2\text{K}$

Exterior heat transfer co-efficient  $h_b = 11\text{ W/m}^2\text{K}$

Interior room temperature  $T_a = 22^\circ\text{C} + 273 = 295\text{ K}$

Outside air temperature  $T_b = -5^\circ\text{C} + 273 = 268\text{ K}$ .

### Solution:

Heat flow through composite wall is given by

$$Q = \frac{\Delta T_{\text{overall}}}{R} \text{ [From equation (13)] (or) [HMT Data book page No. 34]}$$

Where,  $\Delta T = T_a - T_b$

$$R = \frac{1}{h_a A} + \frac{L_1}{K_1 A} + \frac{L_2}{K_2 A} + \frac{L_3}{K_3 A} + \frac{L_4}{K_4 A} + \frac{1}{h_b A}$$
$$\Rightarrow Q = \frac{T_a - T_b}{\frac{1}{h_a A} + \frac{L_1}{K_1 A} + \frac{L_2}{K_2 A} + \frac{L_3}{K_3 A} + \frac{L_4}{K_4 A} + \frac{1}{h_b A}}$$
$$\Rightarrow Q/A = \frac{295 - 268}{\frac{1}{5.6} + \frac{0.20}{0.66} + \frac{0.03}{0.6} + \frac{0.08}{0.58} + \frac{0.012}{0.6} + \frac{1}{11}}$$

$$\boxed{\text{Heat transfer per unit area } Q/A = 34.56 \text{ W/m}^2}$$

We know, Heat transfer  $Q = UA (T_a - T_b)$  [From equation (14)]

Where  $U$  – overall heat transfer co-efficient

$$\Rightarrow U = \frac{Q}{A \times (T_a - T_b)}$$
$$\Rightarrow U = \frac{34.56}{295 - 268}$$

$$\boxed{\text{Overall heat transfer co-efficient } U = 1.28 \text{ W/m}^2 \text{K}}$$

We know

Overall Thermal resistance ( $R$ )

$$R = \frac{1}{h_a A} + \frac{L_1}{K_1 A} + \frac{L_2}{K_2 A} + \frac{L_3}{K_3 A} + \frac{L_4}{K_4 A} + \frac{1}{h_b A}$$

For unit Area

$$R = \frac{1}{h_a} + \frac{L_1}{K_1} + \frac{L_2}{K_2} + \frac{L_3}{K_3} + \frac{L_4}{K_4} + \frac{1}{h_b}$$
$$= \frac{1}{5.6} + \frac{0.20}{0.66} + \frac{0.03}{0.6} + \frac{0.08}{0.58} + \frac{0.012}{0.6} + \frac{1}{11}$$

$$\boxed{R = 0.78 \text{ K/W}}$$

**Interface temperature between mortar and the limestone  $T_3$**

Interface temperatures relation

$$\Rightarrow Q = \frac{T_a - T_1}{R_a} = \frac{T_1 - T_2}{R_1} = \frac{T_2 - T_3}{R_2} = \frac{T_3 - T_4}{R_3} = \frac{T_4 - T_5}{R_4} = \frac{T_5 - T_b}{R_b}$$

$$\Rightarrow Q = \frac{T_a - T_1}{R_a}$$

$$Q = \frac{295 - T_1}{1/h_a} \quad \left[ \because R_a = \frac{1}{h_a A} \right]$$

$$\Rightarrow Q/A = \frac{295 - T_1}{1/h_a}$$

$$\Rightarrow 34.56 = \frac{295 - T_1}{1/5.6}$$

$$\Rightarrow \boxed{T_1 = 288.8 \text{ K}}$$

$$\Rightarrow Q = \frac{T_1 - T_2}{R_1}$$

$$Q = \frac{288.8 - T_2}{\frac{L_1}{K_1 A}} \quad \left[ \because R_1 = \frac{L_1}{k_1 A} \right]$$

$$\Rightarrow Q/A = \frac{288.8 - T_2}{\frac{L_1}{K_1}}$$

$$\Rightarrow 34.56 = \frac{288.8 - T_2}{\frac{0.20}{0.66}}$$

$$\Rightarrow \boxed{T_2 = 278.3 \text{ K}}$$

$$\Rightarrow Q = \frac{T_2 - T_3}{R_2}$$

$$Q = \frac{278.3 - T_3}{\frac{L_2}{K_2 A}} \quad \left[ \because R_2 = \frac{L_2}{K_2 A} \right]$$

$$\Rightarrow Q/A = \frac{278.3 - T_3}{\frac{L_2}{K_2}}$$

$$\Rightarrow 34.56 = \frac{278.3 - T_3}{\frac{0.03}{0.6}}$$

$$\Rightarrow \boxed{T_3 = 276.5 \text{ K}}$$

Temperature between Mortar and limestone ( $T_3$  is 276.5 K)

2. A furnace wall made up of 7.5 cm of fire plate and 0.65 cm of mild steel plate. Inside surface exposed to hot gas at 650°C and outside air temperature 27°C. The convective heat transfer co-efficient for inner side is 60 W/m<sup>2</sup>K. The convective heat transfer co-efficient for outer side is 8W/m<sup>2</sup>K.

Calculate the heat lost per square meter area of the furnace wall and also find outside surface temperature.

**Given Data**

Thickness of fire plate  $L_1 = 7.5 \text{ cm} = 0.075 \text{ m}$

Thickness of mild steel  $L_2 = 0.65 \text{ cm} = 0.0065 \text{ m}$

Inside hot gas temperature  $T_a = 650^\circ\text{C} + 273 = 923 \text{ K}$

Outside air temperature  $T_b = 27^\circ\text{C} + 273 = 300^\circ\text{K}$

Convective heat transfer co-efficient for

Inner side  $h_a = 60 \text{ W/m}^2\text{K}$

Convective heat transfer co-efficient for

Outer side  $h_b = 8 \text{ W/m}^2\text{K}$ .

**Solution:**

(i) **Heat lost per square meter area (Q/A)**

Thermal conductivity for fire plate

$K_1 = 1035 \times 10^{-3} \text{ W/mK}$  [From HMT data book page No.11]

Thermal conductivity for mild steel plate

$K_2 = 53.6 \text{ W/mK}$  [From HMT data book page No.1]

Heat flow  $Q = \frac{\Delta T_{overall}}{R}$ , Where

$$\Delta T = T_a - T_b$$

$$R = \frac{1}{h_a A} + \frac{L_1}{K_1 A} + \frac{L_2}{K_2 A} + \frac{L_3}{K_3 A} + \frac{1}{h_b A}$$
$$\Rightarrow Q = \frac{T_a - T_b}{\frac{1}{h_a A} + \frac{L_1}{K_1 A} + \frac{L_2}{K_2 A} + \frac{L_3}{K_3 A} + \frac{1}{h_b A}}$$

[The term  $L_3$  is not given so neglect that term]

$$\Rightarrow Q = \frac{T_a - T_b}{\frac{1}{h_a A} + \frac{L_1}{K_1 A} + \frac{L_2}{K_2 A} + \frac{L_3}{K_3 A} + \frac{1}{h_b A}}$$

The term  $L_3$  is not given so neglect that term]

$$\Rightarrow Q = \frac{T_a - T_b}{\frac{1}{h_a A} + \frac{L_1}{K_1 A} + \frac{L_2}{K_2 A} + \frac{1}{h_b A}}$$

$$Q/A = \frac{923 - 300}{\frac{1}{60} + \frac{0.075}{1.035} + \frac{0.0065}{53.6} + \frac{1}{8}}$$

$$\boxed{Q/A = 2907.79 \text{ W/m}^2}$$

(ii) **Outside surface temperature  $T_3$**

We know that, Interface temperatures relation

$$Q = \frac{T_a - T_b}{R} = \frac{T_a - T_1}{R_a} = \frac{T_1 - T_2}{R_1} = \frac{T_2 - T_3}{R_2} = \frac{T_3 - T_b}{R_b} \dots\dots(A)$$

$$(A) \Rightarrow Q = \frac{T_3 - T_b}{R_b}$$

where

$$R_b = \frac{1}{h_b A}$$

$$\Rightarrow Q = \frac{T_3 - T_b}{\frac{1}{h_b A}}$$

$$\Rightarrow Q/A = \frac{T_3 - T_b}{\frac{1}{h_b}}$$

$$\Rightarrow 2907.79 = \frac{T_3 - 300}{\frac{1}{8}}$$

$$\boxed{T_3 = 663.473 \text{ K}}$$

3. A steel tube ( $K = 43.26 \text{ W/mK}$ ) of 5.08 cm inner diameter and 7.62 cm outer diameter is covered with 2.5 cm layer of insulation ( $K = 0.208 \text{ W/mK}$ ) the inside surface of the tube receives heat from a hot gas at the temperature of  $316^\circ\text{C}$  with heat transfer co-efficient of  $28 \text{ W/m}^2\text{K}$ . While the outer surface exposed to the ambient air at  $30^\circ\text{C}$  with heat transfer co-efficient of  $17 \text{ W/m}^2\text{K}$ . Calculate heat loss for 3 m length of the tube.



Steel tube thermal conductivity  $K_1 = 43.26 \text{ W/mK}$   
 Inner diameter of steel  $d_1 = 5.08 \text{ cm} = 0.0508 \text{ m}$   
 Inner radius  $r_1 = 0.0254 \text{ m}$   
 Outer diameter of steel  $d_2 = 7.62 \text{ cm} = 0.0762 \text{ m}$   
 Outer radius  $r_2 = 0.0381 \text{ m}$   
 Radius  $r_3 = r_2 + \text{thickness of insulation}$   
 Radius  $r_3 = 0.0381 + 0.025 \text{ m}$       $r_3 = 0.0631 \text{ m}$   
 Thermal conductivity of insulation  $K_2 = 0.208 \text{ W/mK}$   
 Hot gas temperature  $T_a = 316^\circ\text{C} + 273 = 589 \text{ K}$   
 Ambient air temperature  $T_b = 30^\circ\text{C} + 273 = 303 \text{ K}$   
 Heat transfer co-efficient at inner side  $h_a = 28 \text{ W/m}^2\text{K}$   
 Heat transfer co-efficient at outer side  $h_b = 17 \text{ W/m}^2\text{K}$   
 Length  $L = 3 \text{ m}$

**Solution :**

Heat flow  $Q = \frac{\Delta T_{\text{overall}}}{R}$  [From equation No.(19) or HMT data book Page No.35]

Where  $\Delta T = T_a - T_b$

$$R = \frac{1}{2\pi L} \left[ \frac{1}{h_a r_1} + \frac{1}{K_1} \ln \left[ \frac{r_2}{r_1} \right] + \frac{1}{K_2} \ln \left[ \frac{r_3}{r_2} \right] + \frac{1}{K_3} \ln \left[ \frac{r_4}{r_3} \right] + \frac{1}{h_b r_4} \right]$$

$$\Rightarrow Q = \frac{T_a - T_b}{\frac{1}{2\pi L} \left[ \frac{1}{h_a r_1} + \frac{1}{K_1} \ln \left[ \frac{r_2}{r_1} \right] + \frac{1}{K_2} \ln \left[ \frac{r_3}{r_2} \right] + \frac{1}{K_3} \ln \left[ \frac{r_4}{r_3} \right] + \frac{1}{h_b r_4} \right]}$$

[The terms  $K_3$  and  $r_4$  are not given, so neglect that terms]

$$\Rightarrow Q = \frac{T_a - T_b}{\frac{1}{2\pi L} \left[ \frac{1}{h_a r_1} + \frac{1}{K_1} \ln \left[ \frac{r_2}{r_1} \right] + \frac{1}{K_2} \ln \left[ \frac{r_3}{r_2} \right] + \frac{1}{h_b r_3} \right]}$$

$$\Rightarrow Q = \frac{589 - 303}{\frac{1}{2\pi \times 3} \left[ \frac{1}{28 \times 0.0254} + \frac{1}{43.26} \ln \left[ \frac{0.0381}{0.0254} \right] + \frac{1}{0.208} \ln \left[ \frac{0.0631}{0.0381} \right] + \frac{1}{17 \times 0.0631} \right]}$$

$$Q = 1129.42 \text{ W}$$

Heat loss  $Q = 1129.42 \text{ W}$ .

4. An aluminium alloy fin of 7 mm thick and 50 mm long protrudes from a wall, which is maintained at  $120^\circ\text{C}$ . The ambient air temperature is  $22^\circ\text{C}$ . The heat transfer coefficient and conductivity of the fin material are  $140 \text{ W/m}^2\text{K}$  and  $55 \text{ W/mK}$  respectively. Determine
- Temperature at the end of the fin
  - Temperature at the middle of the fin.
  - Total heat dissipated by the fin.

**Given**

Thickness  $t = 7\text{mm} = 0.007\text{ m}$   
Length  $L = 50\text{ mm} = 0.050\text{ m}$   
Base temperature  $T_b = 120^\circ\text{C} + 273 = 393\text{ K}$   
Ambient temperature  $T_\infty = 22^\circ + 273 = 295\text{ K}$   
Heat transfer co-efficient  $h = 140\text{ W/m}^2\text{K}$   
Thermal conductivity  $K = 55\text{ W/mK}$ .

**Solution :**

Length of the fin is 50 mm. So, this is short fin type problem. Assume end is insulated.

We know

Temperature distribution [Short fin, end insulated]

$$\frac{T - T_\infty}{T_b - T_\infty} = \frac{\cos h m [L - x]}{\cos h (mL)} \dots\dots(A)$$

[From HMT data book Page No.41]

**(i) Temperature at the end of the fin, Put  $x = L$**

$$\begin{aligned} (A) \Rightarrow \frac{T - T_\infty}{T_b - T_\infty} &= \frac{\cos h m [L - L]}{\cos h (mL)} \\ \Rightarrow \frac{T - T_\infty}{T_b - T_\infty} &= \frac{1}{\cos h (mL)} \quad \dots(1) \end{aligned}$$

where

$$m = \sqrt{\frac{hP}{KA}}$$

$$\begin{aligned} P = \text{Perimeter} &= 2 \times L \text{ (Approx)} \\ &= 2 \times 0.050 \end{aligned}$$

$$\boxed{P = 0.1\text{ m}}$$

$$A - \text{Area} = \text{Length} \times \text{thickness} = 0.050 \times 0.007$$

$$\boxed{A = 3.5 \times 10^{-4}\text{m}^2}$$

$$\Rightarrow m = \sqrt{\frac{hP}{KA}}$$

$$= \sqrt{\frac{140 \times 0.1}{55 \times 3.5 \times 10^{-4}}}$$

$$\boxed{m = 26.96}$$

$$\begin{aligned}
 (1) \Rightarrow \frac{T - T_{\infty}}{T_b - T_{\infty}} &= \frac{1}{\cos h (26.9 \times 0.050)} \\
 \Rightarrow \frac{T - T_{\infty}}{T_b - T_{\infty}} &= \frac{1}{2.05} \\
 \Rightarrow \frac{T - 295}{393 - 295} &= \frac{1}{2.05} \\
 \Rightarrow T - 295 &= 47.8 \\
 \Rightarrow \boxed{T = 342.8 \text{ K}}
 \end{aligned}$$

Temperature at the end of the fin  $T_{x=L} = 342.8 \text{ K}$

**(ii) Temperature of the middle of the fin,**

Put  $x = L/2$  in Equation (A)

$$\begin{aligned}
 (A) \Rightarrow \frac{T - T_{\infty}}{T_b - T_{\infty}} &= \frac{\cos hm [L-L/2]}{\cos h (mL)} \\
 \Rightarrow \frac{T - T_{\infty}}{T_b - T_{\infty}} &= \frac{\cos h 26.9 \left[ 0.050 - \frac{0.050}{2} \right]}{\cos h [26.9 \times (0.050)]} \\
 \Rightarrow \frac{T - 295}{393 - 295} &= \frac{1.234}{2.049} \\
 \Rightarrow \frac{T - 295}{393 - 295} &= 0.6025 \\
 \Rightarrow \boxed{T = 354.04 \text{ K}}
 \end{aligned}$$

Temperature at the middle of the fin

$$\boxed{T_{x=L/2} = 354.04 \text{ K}}$$

**(iii) Total heat dissipated**

[From HMT data book Page No.41]

$$\begin{aligned}
 \Rightarrow Q &= (hPKA)^{1/2} (T_b - T_{\infty}) \tan h (mL) \\
 \Rightarrow [140 \times 0.1 \times 55 \times 3.5 \times 10^{-4}]^{1/2} \times (393 - 295) \\
 &\quad \times \tan h (26.9 \times 0.050) \\
 \Rightarrow \boxed{Q = 44.4 \text{ W}}
 \end{aligned}$$

5. a) A furnace wall consists of 200 mm layer of refractory bricks, 6mm layer of steel plate and a 100 mm layer of insulation bricks. The maximum temperature of the wall is 1150 °C on the furnace side and the minimum temperature is 40 °C on the outer side of the wall. An accurate energy balance over the furnace shows that the heat loss from wall is 400 W/m<sup>2</sup>K. It is known that there is thin layer of air between the layers of refractory bricks and steel plate. Thermal conductivities for the three layers are 1.52, 45 and 0.138 W/m °C respectively. Find

- 1) To how many millimeters of insulation brick is the air layer equivalent?
- 2) What is the temperature of the outer surface of the steel plate?

$$R_c = \frac{1}{h_c}$$

$$R = \frac{L}{k}$$

Equivalent thickness is determined by

$$L = kR_c$$

- b) Find out the amount of heat transferred through an iron fin of length 50 mm, width 100mm and thickness 5mm. Assume  $k = 210 \text{ kJ/mh}^\circ\text{C}$  and  $h = 42 \text{ kJ/m}^2\text{h}^\circ\text{C}$  for the material of the fin and the temperature at the base of the fin as  $80^\circ\text{C}$ . Also determine the temperature at tip of the fin, if atmosphere temperature is  $20^\circ\text{C}$  [NOV DEC 14]

**Refer problem No. 4 & 10**

6. a) Derive general heat conduction equation in Cartesian coordinates.
- b) Compute the heat loss per square meter surface area of 40 cm thick furnace wall having surface temperature of  $300^\circ\text{C}$  and  $50^\circ\text{C}$  if the thermal conductivity  $k$  of the wall material is given by  $k = 0.005T - 5 \times 10^{-6} T^2$  where  $T = \text{Temperature in } ^\circ\text{C}$  [NOV DEC 14]

$$\left( \begin{array}{c} \text{Rate of heat} \\ \text{conduction at} \\ x, y, \text{ and } z \end{array} \right) - \left( \begin{array}{c} \text{Rate of heat} \\ \text{conduction} \\ \text{at } x + \Delta x, \\ y + \Delta y, \text{ and } z + \Delta z \end{array} \right) + \left( \begin{array}{c} \text{Rate of heat} \\ \text{generation} \\ \text{inside the} \\ \text{element} \end{array} \right) = \left( \begin{array}{c} \text{Rate of change} \\ \text{of the energy} \\ \text{content of} \\ \text{the element} \end{array} \right)$$

or

$$\dot{Q}_x + \dot{Q}_y + \dot{Q}_z - \dot{Q}_{x+\Delta x} - \dot{Q}_{y+\Delta y} - \dot{Q}_{z+\Delta z} + \dot{G}_{\text{element}} = \frac{\Delta E_{\text{element}}}{\Delta t}$$

$$\Delta E_{\text{element}} = E_{t+\Delta t} - E_t = mC(T_{t+\Delta t} - T_t) = \rho C \Delta x \Delta y \Delta z (T_{t+\Delta t} - T_t)$$

$$\dot{Q}_{\text{element}} = \dot{g} V_{\text{element}} = \dot{g} \Delta x \Delta y \Delta z$$

$$\dot{Q}_x + \dot{Q}_y + \dot{Q}_z - \dot{Q}_{x+\Delta x} - \dot{Q}_{y+\Delta y} - \dot{Q}_{z+\Delta z} + \dot{g} \Delta x \Delta y \Delta z = \rho C \Delta x \Delta y \Delta z \frac{T_{t+\Delta t} - T_t}{\Delta t}$$

Dividing by  $\Delta x \Delta y \Delta z$  gives

$$-\frac{1}{\Delta y \Delta z} \frac{\dot{Q}_{x+\Delta x} - \dot{Q}_x}{\Delta x} - \frac{1}{\Delta x \Delta z} \frac{\dot{Q}_{y+\Delta y} - \dot{Q}_y}{\Delta y} - \frac{1}{\Delta x \Delta y} \frac{\dot{Q}_{z+\Delta z} - \dot{Q}_z}{\Delta z} + \dot{g} = \rho C \frac{T_{t+\Delta t} - T_t}{\Delta t}$$

$$\frac{\partial}{\partial x} \left( k \frac{\partial T}{\partial x} \right) + \frac{\partial}{\partial y} \left( k \frac{\partial T}{\partial y} \right) + \frac{\partial}{\partial z} \left( k \frac{\partial T}{\partial z} \right) + \dot{g} = \rho C \frac{\partial T}{\partial t}$$

$$\frac{\partial^2 T}{\partial x^2} + \frac{\partial^2 T}{\partial y^2} + \frac{\partial^2 T}{\partial z^2} + \frac{\dot{g}}{k} = \frac{1}{\alpha} \frac{\partial T}{\partial t}$$

Sub values we have for cylinder

$$A_1 = 2\pi(60 \times 10^{-3})60$$

$$A_3 = 2\pi(160 \times 10^{-3})60$$

$$R_i = \frac{1}{h_1 A_1}$$

$$R_1 = \frac{\ln\left(\frac{r_2}{r_1}\right)}{2\pi L K_1}$$

$$R_2 = \frac{\ln\left(\frac{r_3}{r_2}\right)}{2\pi L K_2}$$

$$R_0 = \frac{1}{h_2 A_2}$$

$$R_{\text{total}} = R_i + R_1 + R_2 + R_0$$

$$Q = \frac{T_{\infty 1} - T_{\infty 2}}{R_{\text{total}}}$$

7. Alloy steel ball of 2 mm diameter heated to 800°C is quenched in a bath at 100°C. The material properties of the ball are  $K = 205 \text{ kJ/m hr K}$ ,  $\rho = 7860 \text{ kg/m}^3$ ,  $C_p = 0.45 \text{ kJ/kg K}$ ,  $h = 150 \text{ KJ/hr m}^2 \text{ K}$ . Determine (i) Temperature of ball after 10 second and (ii) Time for ball to cool to 400°C.

Diameter of the ball  $D = 12 \text{ mm} = 0.012 \text{ m}$

Radius of the ball  $R = 0.006 \text{ m}$

Initial temperature  $T_0 = 800^\circ\text{C} + 273 = 1073 \text{ K}$

Final temperature  $T_{\infty} = 100^{\circ}\text{C} + 273 = 373 \text{ K}$

Thermal conductivity  $K = 205 \text{ kJ/m hr K}$

$$\begin{aligned} &= \frac{205 \times 1000 \text{ J}}{3600 \text{ s m K}} \\ &= 56.94 \text{ W/mK} \quad [ \because \text{J/s} = \text{W} ] \end{aligned}$$

Density  $\rho = 7860 \text{ kg/m}^3$

Specific heat  $C_p = 0.45 \text{ kJ/kg K}$   
 $= 450 \text{ J/kg K}$

Heat transfer co-efficient  $h = 150 \text{ kJ/hr m}^2 \text{ K}$

$$\begin{aligned} &= \frac{150 \times 1000 \text{ J}}{3600 \text{ s m}^2 \text{ K}} \\ &= 41.66 \text{ W/m}^2 \text{ K} \end{aligned}$$

### Solution

#### Case (i) Temperature of ball after 10 sec.

For sphere,

$$\begin{aligned} \text{Characteristic Length } L_c &= \frac{R}{3} \\ &= \frac{0.006}{3} \end{aligned}$$

$$L_c = 0.002 \text{ m}$$

We know,

$$\begin{aligned} \text{Biot number } B_i &= \frac{hL_c}{K} \\ &= \frac{41.667 \times 0.002}{56.94} \end{aligned}$$

$$B_i = 1.46 \times 10^{-3} < 0.1$$

Biot number value is less than 0.1. So this is lumped heat analysis type problem.

For lumped parameter system,

$$\frac{T - T_{\infty}}{T_0 - T_{\infty}} = e^{\left[ \frac{-hA}{C_p \times V \times \rho} \times t \right]} \dots\dots\dots(1)$$

[From HMT data book Page No.48]

We know,

$$\text{Characteristics length } L_c = \frac{V}{A}$$

$$(1) \Rightarrow \frac{T - T_{\infty}}{T_0 - T_{\infty}} = e^{\left[ \frac{-h}{C_{\rho} \times L_c \times \rho} \times t \right]} \dots\dots\dots(2)$$

$$\Rightarrow \frac{T - 373}{1073 - 373} = e^{\left[ \frac{-41.667}{450 \times 0.002 \times 7860} \times 10 \right]}$$

$$\Rightarrow \boxed{T = 1032.95 \text{ K}}$$

**Case (ii) Time for ball to cool to 400°C**

$$\therefore T = 400^{\circ}\text{C} + 273 = 673 \text{ K}$$

$$(2) \Rightarrow \frac{T - T_{\infty}}{T_0 - T_{\infty}} = e^{\left[ \frac{-h}{C_{\rho} \times L_c \times \rho} \times t \right]} \dots\dots\dots(2)$$

$$\Rightarrow \frac{673 - 373}{1073 - 373} = e^{\left[ \frac{-41.667}{450 \times 0.002 \times 7860} \times t \right]}$$

$$\Rightarrow \ln \left[ \frac{673 - 373}{1073 - 373} \right] = \frac{-41.667}{450 \times 0.002 \times 7860} \times t$$

$$\Rightarrow \boxed{t = 143.849 \text{ s}}$$

8. Derive the general heat conduction equation in cylindrical coordinate and solve the following. Hot air at a temperature of 65 °C is flowing through steel pipe of 120 mm diameter. The pipe is Covered with two layers of different insulating materials of thickness 60 mm and 40 mm and their Corresponding thermal conductivities are 0.24 and 0.4 W/ m K. The inside and outside heat transfer coefficients are 60 W/m<sup>2</sup> K and 12 W/m<sup>2</sup> K respectively. The atmosphere is at 20°C. Find the rate of heat loss from 60 m length of pipe. **[MAY-JUN 14]**

In cylindrical coordinate  $(r, \Phi, z)$ ,

$$\frac{1}{r} \frac{\partial}{\partial r} \left( kr \frac{\partial T}{\partial r} \right) + \frac{1}{r^2} \frac{\partial}{\partial \Phi} \left( k \frac{\partial T}{\partial \Phi} \right) + \frac{\partial}{\partial z} \left( k \frac{\partial T}{\partial z} \right) + q = \rho c \frac{\partial T}{\partial \tau}$$

With  $k$  constant eqn. in 2.4 reduces to

$$\frac{1}{r} \frac{\partial}{\partial r} \left( r \frac{\partial T}{\partial r} \right) + \frac{1}{r^2} \frac{\partial^2 T}{\partial \Phi^2} + \frac{\partial^2 T}{\partial z^2} + \frac{q}{k} = \frac{1}{\alpha} \cdot \frac{\partial T}{\partial \tau}$$

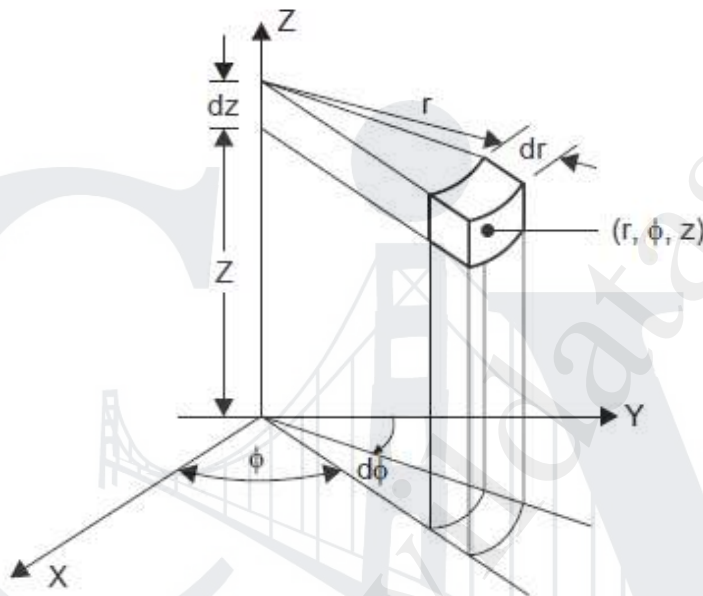

Elemental volume in cylindrical coordinates.

9. Steam in a heating system flows through tubes whose outer diameter is  $D_1 = 3$  cm and whose walls are maintained at a temperature of  $120^\circ\text{C}$ . Circular aluminum fins ( $k = 180 \text{ W/m} \cdot ^\circ\text{C}$ ) of outer diameter  $D_2 = 6$  cm and constant thickness  $t = 2$  mm are attached to the tube. The space between the fins is 3 mm, and thus there are 200 fins per meter length of the tube. Heat is transferred to the surrounding air at  $T_\infty = 25^\circ\text{C}$ , with a combined heat transfer coefficient of  $h = 60 \text{ W/m}^2 \cdot ^\circ\text{C}$ . Determine the increase in heat transfer from the tube per meter of its length as a result of adding fins.

$$\begin{aligned} A_{\text{no fin}} &= \pi D_1 L = \pi(0.03 \text{ m})(1 \text{ m}) = 0.0942 \text{ m}^2 \\ \dot{Q}_{\text{no fin}} &= h A_{\text{no fin}} (T_b - T_\infty) \\ &= (60 \text{ W/m}^2 \cdot ^\circ\text{C})(0.0942 \text{ m}^2)(120 - 25)^\circ\text{C} \\ &= 537 \text{ W} \end{aligned}$$



$$\begin{aligned} A_{\text{fin}} &= 2\pi(r_2^2 - r_1^2) + 2\pi r_2 t \\ &= 2\pi[(0.03 \text{ m})^2 - (0.015 \text{ m})^2] + 2\pi(0.03 \text{ m})(0.002 \text{ m}) \\ &= 0.00462 \text{ m}^2 \end{aligned}$$

$$\begin{aligned} \dot{Q}_{\text{fin}} &= \eta_{\text{fin}} \dot{Q}_{\text{fin, max}} = \eta_{\text{fin}} h A_{\text{fin}} (T_b - T_{\infty}) \\ &= 0.95(60 \text{ W/m}^2 \cdot ^\circ\text{C})(0.00462 \text{ m}^2)(120 - 25)^\circ\text{C} \\ &= 25.0 \text{ W} \end{aligned}$$

$$\begin{aligned} A_{\text{unfin}} &= \pi D_1 S = \pi(0.03 \text{ m})(0.003 \text{ m}) = 0.000283 \text{ m}^2 \\ \dot{Q}_{\text{unfin}} &= h A_{\text{unfin}} (T_b - T_{\infty}) \\ &= (60 \text{ W/m}^2 \cdot ^\circ\text{C})(0.000283 \text{ m}^2)(120 - 25)^\circ\text{C} \\ &= 1.60 \text{ W} \end{aligned}$$

$$\dot{Q}_{\text{total, fin}} = n(\dot{Q}_{\text{fin}} + \dot{Q}_{\text{unfin}}) = 200(25.0 + 1.6) \text{ W} = 5320 \text{ W}$$

$$\dot{Q}_{\text{increase}} = \dot{Q}_{\text{total, fin}} - \dot{Q}_{\text{no fin}} = 5320 - 537 = \mathbf{4783 \text{ W}} \quad (\text{per m tube length})$$

10. Copper plate fins of rectangular cross section having thickness  $t = 1 \text{ mm}$ , height  $L = 10 \text{ mm}$  and thermal conductivity  $k = 380 \text{ W/mK}$  are attached to a plane wall maintained at a temperature  $T_0 = 230^\circ\text{C}$ . Fins dissipate heat by convection in to ambient air at  $T = 30^\circ\text{C}$  with a heat transfer coefficient  $h = 40 \text{ W/m}^2 \text{ K}$ . Fins are spaced at  $8 \text{ mm}$  ( that is 125 fins per meter). Assume negligible heat loss from the tip.
- Determine the fin efficiency
  - Determine the fin effectiveness.
  - Determine the net rate of heat transfer per square meter of plane surface
  - What would be heat transfer rate from the plane wall if there were no fins attached?

$$\eta_{\text{insulated tip}} = \frac{\dot{Q}_{\text{fin}}}{\dot{Q}_{\text{fin, max}}} = \frac{\sqrt{hp k A_c} (T_b - T_{\infty}) \tanh aL}{h A_{\text{fin}} (T_b - T_{\infty})} = \frac{\tanh aL}{aL}$$

$$\varepsilon_{\text{fin}} = \frac{\dot{Q}_{\text{fin}}}{\dot{Q}_{\text{no fin}}} = \frac{\dot{Q}_{\text{fin}}}{h A_b (T_b - T_{\infty})} = \frac{\eta_{\text{fin}} h A_{\text{fin}} (T_b - T_{\infty})}{h A_b (T_b - T_{\infty})} = \frac{A_{\text{fin}}}{A_b} \eta_{\text{fin}}$$

$$Q_{\text{net}} = Q_{\text{fin}} + Q_{\text{unfin}} = 26.87 \text{ kW/m}^2$$

$$Q_{\text{nofin}} = 8 \text{ kW/m}^2$$

11. Derive the heat dissipation equation through pin fin with insulated end and solve the following. A temperature rise of 50 C in a circular shaft of 50 mm diameter is caused by the amount of heat generated due to friction in the bearing mounted on the crankshaft. The thermal conductivity of shaft material is 55 W/m K and heat transfer coefficient is 7 W/m<sup>2</sup> K. Determine the amount of heat transferred through shaft assume that the shaft is a rod of infinite length. [MAY-JUN 14]

$$\left( \begin{array}{l} \text{Rate of heat} \\ \text{conduction into} \\ \text{the element at } x \end{array} \right) = \left( \begin{array}{l} \text{Rate of heat} \\ \text{conduction from the} \\ \text{element at } x + \Delta x \end{array} \right) + \left( \begin{array}{l} \text{Rate of heat} \\ \text{convection from} \\ \text{the element} \end{array} \right)$$

$$\dot{Q}_{\text{cond},x} = \dot{Q}_{\text{cond},x+\Delta x} + \dot{Q}_{\text{conv}}$$

where

$$\dot{Q}_{\text{conv}} = h(p \Delta x)(T - T_{\infty})$$

Substituting and dividing by  $\Delta x$ , we obtain

$$\frac{\dot{Q}_{\text{cond},x+\Delta x} - \dot{Q}_{\text{cond},x}}{\Delta x} + hp(T - T_{\infty}) = 0$$

Taking the limit as  $\Delta x \rightarrow 0$  gives

$$\frac{d\dot{Q}_{\text{cond}}}{dx} + hp(T - T_{\infty}) = 0$$

From Fourier's law of heat conduction we have

$$\dot{Q}_{\text{cond}} = -kA_c \frac{dT}{dx}$$

$$\frac{d}{dx} \left( kA_c \frac{dT}{dx} \right) - hp(T - T_\infty) = 0$$

$$\frac{d^2\theta}{dx^2} - a^2\theta = 0$$

where

$$a^2 = \frac{hp}{kA_c}$$

and  $\theta = T - T_\infty$  is the *temperature excess*. At the fin base we have  $\theta_b = T_b - T_\infty$ .

Boundary condition at fin tip:

$$\left. \frac{d\theta}{dx} \right|_{x=L} = 0$$

Adiabatic fin tip:

$$\frac{T(x) - T_\infty}{T_b - T_\infty} = \frac{\cosh a(L - x)}{\cosh aL}$$

Adiabatic fin tip:

$$\begin{aligned} \dot{Q}_{\text{insulated tip}} &= -kA_c \left. \frac{dT}{dx} \right|_{x=0} \\ &= \sqrt{hpkA_c} (T_b - T_\infty) \tanh aL \end{aligned}$$

Sub values we have

$$\dot{Q}_{\text{insulated tip}} = 17.23 \text{ W}$$

12. (i) A turbine blade 6 cm long and having a cross sectional area 4.65 cm<sup>2</sup> and perimeter 12 cm is made of stainless steel ( k = 23.3 W/m K). The temperature at the root is 500 °C. The blade is exposed to a hot gas at 870 °C. The heat transfer coefficient between the blade surface and gas is 442 W/m<sup>2</sup> K. Determine the temperature distribution and rate of heat flow at the root of the blade. Assume the tip of the blade to be insulated.
- (ii) An ordinary egg can be approximated as 5 cm diameter sphere. The egg is initially at a uniform temperature of 5°C and is dropped in to boiling water at 95 °C. Taking the convection heat transfer coefficient to be h = 1200 W/m<sup>2</sup> °C. determine how long it will take for the center of the egg to reach 70 °C. [NOV-DEC 13]

$$Bi = \frac{hr_0}{k} = \frac{(1200 \text{ W/m}^2 \cdot \text{°C})(0.025 \text{ m})}{0.627 \text{ W/m} \cdot \text{°C}} = 47.8$$

$$\lambda_1 = 3.0753, \quad A_1 = 1.9958$$

$$\frac{T_o - T_\infty}{T_i - T_\infty} = A_1 e^{-\lambda_1^2 \tau} \longrightarrow \frac{70 - 95}{5 - 95} = 1.9958 e^{-(3.0753)^2 \tau} \longrightarrow \tau = 0.209$$

$$t = \frac{\tau r_o^2}{\alpha} = \frac{(0.209)(0.025 \text{ m})^2}{0.151 \times 10^{-6} \text{ m}^2/\text{s}} = 865 \text{ s}$$

## UNIT-2 CONVECTION

### PART-A

#### 1. Define convection.

Convection is a process of heat transfer that will occur between a solid surface and a fluid medium when they are at different temperatures.

#### 2. What is difference between free convection and forced convection?

If the fluid motion is produced due to change in density resulting from temperature gradients, the mode of heat transfer is said to be free convection and if the fluid motion is artificially created by means of an external force like a blower or fan, the type of heat transfer is known as forced convection.

#### 3. Define Reynolds number (Re) & Prandtl number (Pr).

**Reynolds number** is defined as the ratio of inertia force to viscous force.

$$\text{Re} = \frac{\text{Inertia force}}{\text{Viscous force}}$$

**Prandtl number** is the ratio of the momentum diffusivity of the thermal diffusivity.

$$\text{Pr} = \frac{\text{Momentum diffusivity}}{\text{Thermal diffusivity}}$$

#### 4. Define Nusselt number (Nu).

It is defined as the ratio of the heat flow by convection process under an unit temperature gradient to the heat flow rate by conduction under an unit temperature gradient through a stationary thickness (L) of metre.

$$\text{Nusselt number (Nu)} = \frac{Q_{\text{conv.}}}{Q_{\text{cond}}}$$

#### 5. Define Grashoff number (Gr) & Stanton number (St). [NOV-DEC 14]

It is defined as the ratio of product of inertia force and buoyancy force to the square of viscous force.

$$\text{Gr} = \frac{\text{Inertia force} \times \text{Buyoyancy force}}{(\text{Viscous force})^2}$$

**Stanton number** is the ratio of Nusselt number to the product of Reynolds number and Prandtl number.

$$St = \frac{Nu}{Re \times Pr}$$

**6. What is meant by Newtonian and non – Newtonian fluids?**

The fluids which obey the Newton's Law of viscosity are called Newtonian fluids and those which do not obey are called non – Newtonian fluids.

**7. What is meant by laminar flow and turbulent flow?**

**Laminar flow:** Laminar flow is sometimes called stream line flow. In this type of flow, the fluid moves in layers and each fluid particle follows a smooth continuous path. The fluid particles in each layer remain in an orderly sequence without mixing with each other.

**Turbulent flow:** In addition to the laminar type of flow, a distinct irregular flow is frequently observed in nature. This type of flow is called turbulent flow. The path of any individual particle is zig – zag and irregular. Fig. shows the instantaneous velocity in laminar and turbulent flow.

**8. What is meant by hydrodynamic boundary layer and thermal boundary layer?**

In hydrodynamic boundary layer, velocity of fluid is less than 99% of free stream velocity.

In thermal boundary layer, the temperature of the fluid is less than 99% of free stream temperature.

**9. Define boundary layer thickness.**

The thickness of the boundary layer has been defined as the distance from the surface at which the local velocity or temperature reaches 99% of the external velocity or temperature.

**10. What is the form of equation used to calculate heat transfer for flow through cylindrical pipes?**

$$Nu = 0.023 (Re)^{0.8} (Pr)^n$$

n = 0.4 for heating of fluids

n = 0.3 for cooling of fluids

**11 Differentiate viscous sublayer and buffer layer [MAY JUN 14]**

The very thin layer next to the wall where the viscous effects are dominant is the laminar sublayer or viscous sublayer. The velocity profile in this layer is nearly linear, and the flow is streamlined. Next to the laminar sublayer is the buffer layer, in which the turbulent effects are significant but not dominant of the diffusion effects

**12. Define Grashoff number and Prandtl number. [MAY JUN 14]**

The flow regime in natural convection is governed by the dimensionless Grashof number, which represents the ratio of the buoyancy force to the viscous force acting on the fluid

$$Gr_L = \frac{g\beta(T_s - T_\infty)L_c^3}{\nu^2}$$

The relative thickness of the velocity and the thermal boundary layers is best described by the dimensionless parameter Prandtl number.

$$Pr = \frac{\text{Molecular diffusivity of momentum}}{\text{Molecular diffusivity of heat}} = \frac{\nu}{\alpha} = \frac{\mu C_p}{k}$$

**13. Define the thermal boundary layer. [NOV-DEC 13]**

The flow region over the surface in which the temperature variation in the direction normal to the surface is significant is the thermal boundary layer.

Thermal boundary layer develops when a fluid at a specified temperature flows over a surface that is at a different temperature

**14. Why heat transfer coefficient for natural convection is much lesser than that of forced convection? [NOV-DEC 13]**

The convection heat transfer coefficient will usually be higher in forced convection and lower in free convection since heat transfer coefficient depends on the fluid velocity, and free convection involves lower fluid velocities.

**15. What is natural convection? How does it differ from forced convection? What force causes natural convection currents?**

Natural convection is the mode of heat transfer that occurs between a solid and a fluid which moves under the influence of natural means. Natural convection differs from forced convection in that fluid motion in natural convection is caused by natural effects such as buoyancy.

**16. How does the Rayleigh number differ from the Grashof number?**

Rayleigh number is the product of the Grashof and Prandtl numbers.

**17. Consider laminar natural convection from a vertical hot plate. Will the heat flux be higher at the top or at the bottom of the plate? Why?**

The heat flux will be higher at the bottom of the plate since the thickness of the boundary layer which is a measure of thermal resistance is the lowest there.

**18. Why are heat sinks with closely packed fins not suitable for natural convection heat transfer, although they increase the heat transfer surface area more?**

A heat sink with closely packed fins will have greater surface area for heat transfer, but smaller heat transfer coefficient because of the extra resistance the additional fins introduce to fluid flow through the inter fin passages.

**19. When is natural convection negligible and when is it not negligible in forced convection heat transfer?**

In combined natural and forced convection, the natural convection is negligible when  $Gr/Re^2 < 0.1$  Otherwise it is not.

**20. Under what conditions does natural convection enhance forced convection, and under what conditions does it hurt forced convection?**

In assisting or transverse flows, natural convection enhances forced convection heat transfer while in opposing flow it hurts forced convection.

**21. What is drag? What causes it? Why do we usually try to minimize it?**

The force a flowing fluid exerts on a body in the flow direction is called drag. Drag is caused by friction between the fluid and the solid surface, and the pressure difference between the front and back of the body. We try to minimize drag in order to reduce fuel consumption in vehicles, improve safety and durability of structures subjected to high winds, and to reduce noise and vibration.

**22. What is the difference between the upstream velocity and the free-stream velocity? For what types of flow are these two velocities equal to each other?**

The velocity of the fluid relative to the immersed solid body sufficiently far away from a body is called the free-stream velocity  $V_\infty$ . The upstream (or approach) velocity  $V$  is the velocity of the approaching fluid far ahead of the body. These two velocities are equal if the flow is uniform and the body is small relative to the scale of the free-stream flow.

**23. What is flow separation? What causes it? What is the effect of flow separation on the drag coefficient?**

At sufficiently high velocities, the fluid stream detaches itself from the surface of the body. This is called separation. It is caused by a fluid flowing over a curved surface at a high velocity (or by adverse pressure gradient). Separation increases the drag coefficient drastically.

**24. How is the hydrodynamic entry length defined for flow in a tube? Is the entry length longer in laminar or turbulent flow?**

The region from the tube inlet to the point at which the boundary layer merges at the centerline is called the hydrodynamic entry region, and the length of this region is called hydrodynamic entry length. The entry length is much longer in laminar flow than it is in turbulent flow. But at very low Reynolds numbers,  $L_h$  is very small ( $L = 1.2D$  at  $Re = 20$ ).

**25. How does surface roughness affect the heat transfer in a tube if the fluid flow is turbulent? what would be the effect if the flow in the tube were laminar?**

The tubes with rough surfaces have much higher heat transfer coefficients than the tubes with smooth surfaces. In the case of laminar flow, the effect of surface roughness on the heat transfer coefficient is negligible.

## PART B

1. Air at 20°C, at a pressure of 1 bar is flowing over a flat plate at a velocity of 3 m/s. if the plate maintained at 60°C, calculate the heat transfer per unit width of the plate. Assuming the length of the plate along the flow of air is 2m.

**Given :** Fluid temperature  $T_{\infty} = 20^{\circ}\text{C}$ , Pressure  $p = 1 \text{ bar}$ ,  
Velocity  $U = 3 \text{ m/s}$ , Plate surface temperature  $T_w = 60^{\circ}\text{C}$ ,  
Width  $W = 1 \text{ m}$ , Length  $L = 2 \text{ m}$ .

**Solution :** We know,

$$\text{Film temperature } T_f = \frac{T_w + T_{\infty}}{2}$$
$$= \frac{60 + 20}{2}$$
$$T_f = 40^{\circ}\text{C}$$

**Properties of air at 40°C:**

Density  $\rho = 1.129 \text{ Kg/m}^3$  Thermal conductivity  $K = 26.56 \times 10^{-3} \text{ W/mK}$ ,

Kinematic viscosity  $\nu = 16.96 \times 10^{-6} \text{ m}^2/\text{s}$ . Prandtl number  $\text{Pr} = 0.699$

We know, Reynolds number  $\text{Re} = \frac{UL}{\nu} = \frac{3 \times 2}{16.96 \times 10^{-6}}$   
 $= 35.377 \times 10^4$

$$\text{Re} = 35.377 \times 10^4 < 5 \times 10^5$$

Reynolds number value is less than  $5 \times 10^5$ , so this is laminar flow.

For flat plate, Laminar flow,

$$\text{Local Nusselt Number } \text{Nu}_x = 0.332 (\text{Re})^{0.5} (\text{Pr})^{0.333}$$

$$\text{Nu}_x = 0.332 (35.377 \times 10^4)^{0.5} \times (0.699)^{0.333}$$

$$\text{Nu}_x = 175.27$$

We know that,

$$\text{Local Nusselt Number } \text{Nu}_x = \frac{h_s \times L}{K}$$

$$\Rightarrow 175.27 = \frac{h_s \times 2}{26.56 \times 10^{-3}}$$

Local heat transfer coefficient  $h_x = 2.327 \text{ W/m}^2\text{K}$       We know,

Average heat transfer coefficient  $h = 2 \times h_x$        $h = 2 \times 2.327$

$$h = 4.65 \text{ W/m}^2\text{K}$$

Heat transfer  $Q = h A (T_w - T_\infty)$

$$= 4.65 \times 2 (60 - 20)$$

[ $\therefore$  Area = width  $\times$  length =  $1 \times 2 = 2$ ]

$$Q = 372 \text{ Watts.}$$

2. Air at  $30^\circ\text{C}$  flows over a flat plate at a velocity of  $2 \text{ m/s}$ . The plate is  $2 \text{ m}$  long and  $1.5 \text{ m}$  wide. Calculate the following:
- Boundary layer thickness at the trailing edge of the plate,
  - Total drag force,
  - Total mass flow rate through the boundary layer between  $x = 40 \text{ cm}$  and  $x = 85 \text{ cm}$ .

**Given:** Fluid temperature  $T_\infty = 30^\circ\text{C}$

Velocity       $U = 2 \text{ m/s}$

Length       $L = 2 \text{ m}$

Wide  $W$        $W = 1.5 \text{ m}$

To find:

Boundary layer thickness

Total drag force.

Total mass flow rate through the boundary layer between  $x = 40 \text{ cm}$  and  $x = 85 \text{ cm}$ .

**Solution:** Properties of air at  $30^\circ\text{C}$

$$\rho = 1.165 \text{ kg/m}^3$$

$$\nu = 16 \times 10^{-6} \text{ m}^2/\text{s}$$

$$\text{Pr} = 0.701$$

$$K = 26.75 \times 10^{-3} \text{ W/mK}$$

We know,



$$\text{Reynolds number } Re = \frac{UL}{\nu}$$

$$= \frac{2 \times 2}{16 \times 10^{-6}}$$

$$Re = 2.5 \times 10^5 < 5 \times 10^5$$

Since  $Re < 5 \times 10^5$ , flow is laminar

For flat plate, laminar flow, [from HMT data book, Page No.99]

Hydrodynamic boundary layer thickness

$$\begin{aligned} \delta_{hx} &= 5 \times x \times (Re)^{-0.5} \\ &= 5 \times 2 \times (2.5 \times 10^5)^{-0.5} \end{aligned}$$

$$\delta_{hx} = 0.02 \text{ m}$$

Thermal boundary layer thickness,

$$\begin{aligned} \delta_{tx} &= \delta_{hx} \times (Pr)^{-0.333} \\ &= 0.02 \times (0.701)^{-0.333} \end{aligned}$$

$$\delta_{TX} = 0.0225 \text{ m}$$

We know, Average friction coefficient,

$$\begin{aligned} \overline{C}_{fL} &= 1.328 (Re)^{-0.5} \\ &= 1.328 \times (2.5 \times 10^5)^{-0.5} \end{aligned}$$

$$\overline{C}_{fL} = 2.65 \times 10^{-3}$$

We know

$$\overline{C}_{fL} = \frac{t}{\frac{\rho U^2}{2}}$$

$$\Rightarrow 2.65 \times 10^{-3} = \frac{t}{\frac{1.165 \times (2)^2}{2}}$$

$$\Rightarrow \text{Average shear stress } t = 6.1 \times 10^{-3} \text{ N/m}^2$$

Drag force = Area  $\times$  Average shear stress

$$= 2 \times 1.5 \times 6.1 \times 10^{-3}$$

$$\text{Drag force} = 0.018 \text{ N}$$

Drag force on two sides of the plate

$$= 0.018 \times 2$$

$$= 0.036 \text{ N}$$

Total mass flow rate between  $x = 40 \text{ cm}$  and  $x = 85 \text{ cm}$ .

$$\Delta m = \frac{5}{8} \rho U [\delta_{hx=85} - \delta_{hx=40}]$$

Hydrodynamic boundary layer thickness

$$\begin{aligned} \delta_{hx=0.85} &= 5 \times x \times (\text{Re})^{-0.5} \\ &= 5 \times 0.85 \times \left[ \frac{U \times x}{\nu} \right]^{-0.5} \end{aligned}$$

$$= 5 \times 0.85 \times \left[ \frac{2 \times 0.85}{16 \times 10^{-6}} \right]^{-0.5}$$

$$\delta_{HX=0.85} = 0.0130 \text{ m}$$

$$\delta_{hx=0.40} = 5 \times x \times (\text{Re})^{-0.5}$$

$$= 5 \times 0.40 \times \left( \frac{U \times x}{\nu} \right)^{-0.5}$$

$$= 5 \times 0.40 \times \left( \frac{2 \times 0.40}{16 \times 10^{-6}} \right)^{-0.5}$$

$$\delta_{HX=0.40} = 8.9 \times 10^{-3} \text{ m}$$

$$(1) \Rightarrow \Delta m = \frac{5}{8} \times 1.165 \times 2 [0.0130 - 8.9 \times 10^{-3}]$$

$$\Delta m = 5.97 \times 10^{-3} \text{ Kg/s,}$$

3. In a surface condenser, water flows through staggered tubes while the air is passed in cross flow over the tubes. The temperature and velocity of air are 30°C and 8 m/s respectively. The longitudinal and transverse pitches are 22mm and 20mm respectively. The tube outside diameter is 18mm and tube surface temperature is 90°C. Calculate the heat transfer coefficient.

$$V_{\max} = \frac{S_T}{S_T - D} V$$

$$Re_D = \frac{\rho V_{\max} D}{\mu}$$

$$Nu_D = 0.27 Re_D^{0.63} Pr^{0.36} (Pr/Pr_s)^{0.25}$$

$$Nu_{D, N_L} = F Nu_D$$

$$h = \frac{Nu_{D, N_L} k}{D}$$

4. 250 Kg/hr of air are cooled from 100°C to 30°C by flowing through a 3.5 cm inner diameter pipe coil bent in to a helix of 0.6 m diameter. Calculate the value of air side heat transfer coefficient if the properties of air at 65°C are
- K = 0.0298 W/mK
  - $\mu = 0.003 \text{ Kg/hr} - \text{m}$
  - Pr = 0.7
  - $\rho = 1.044 \text{ Kg/m}^3$

**Given :** Mass flow rate in = 205 kg/hr

$$= \frac{205}{3600} \text{ Kg/s in} = 0.056 \text{ Kg/s}$$

Inlet temperature of air  $T_{mi} = 100^\circ\text{C}$

Outlet temperature of air  $T_{mo} = 30^\circ\text{C}$

Diameter  $D = 3.5 \text{ cm} = 0.035 \text{ m}$

$$\text{Mean temperature } T_m = \frac{T_{mi} + T_{mo}}{2} = 65^\circ\text{C}$$

**To find:** Heat transfer coefficient (h)

**Solution:**

$$\text{Reynolds Number } Re = \frac{UD}{\nu}$$

$$\text{Kinematic viscosity } \nu = \frac{\mu}{\rho}$$

$$\frac{0.003 \text{ Kg/s} \cdot \text{m}}{3600}$$
$$\frac{1.044 \text{ Kg/m}^3}$$

$$\nu = 7.98 \times 10^{-7} \text{ m}^2/\text{s}$$

$$\text{Mass flow rate in} = \rho A U$$

$$0.056 = 1.044 \times \frac{\pi}{4} \times D^2 \times U$$

$$0.056 = 1.044 \times \frac{\pi}{4} \times (0.035)^2 \times U$$

$$\Rightarrow U = 55.7 \text{ m/s}$$

$$(1) \Rightarrow Re = \frac{UD}{\nu}$$

$$= \frac{55.7 \times 0.035}{7.98 \times 10^{-7}}$$

$$Re = 2.44 \times 10^6$$

Since  $Re > 2300$ , flow is turbulent

For turbulent flow, general equation is ( $Re > 10000$ )

$$Nu = 0.023 \times (Re)^{0.8} \times (Pr)^{0.3}$$

This is cooling process, so  $n = 0.3$

$$\Rightarrow Nu = 0.023 \times (2.44 \times 10^6)^{0.8} \times (0.7)^{0.3}$$

$$Nu = 2661.7$$

We know that,  $Nu = \frac{hD}{K}$

$$2661.7 = \frac{h \times 0.035}{0.0298}$$

Heat transfer coefficient  $h = 2266.2 \text{ W/m}^2\text{K}$

5. a) Explain about velocity boundary layer on a flat plate

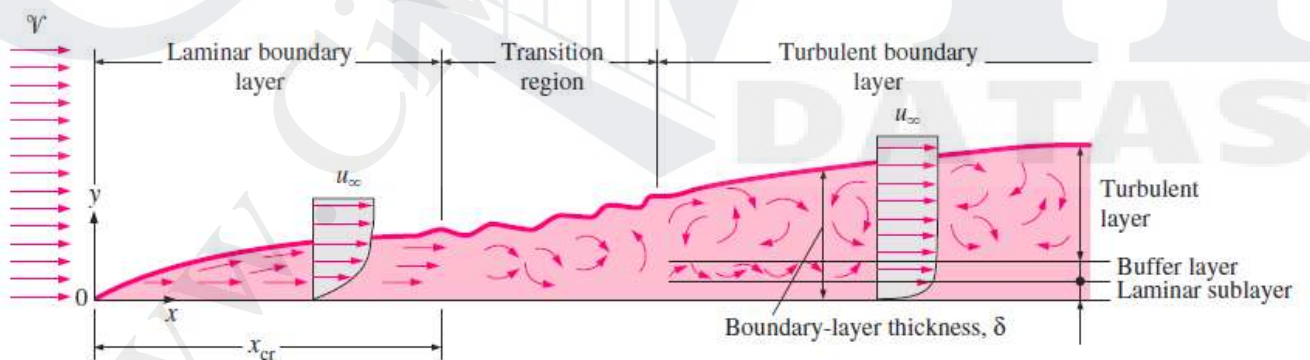

The development of the boundary layer for flow over a flat plate, and the different flow regimes.

b) Assuming that a man can be represented by a cylinder 30 cm in diameter and 1.7 m high with surface temperature of  $30^\circ\text{C}$ , calculate the heat he would lose while standing in a 36 kmph wind at  $10^\circ\text{C}$   
[NOV DEC 14]

$$Re = \frac{VD}{\nu}$$

$$Nu = \frac{hD}{k} = 0.3 + \frac{0.62 Re^{1/2} Pr^{1/3}}{[1 + (0.4/Pr)^{2/3}]^{1/4}} \left[ 1 + \left( \frac{Re}{282,000} \right)^{5/8} \right]^{4/5}$$

$$h = \frac{k}{D} Nu$$

$$A_s = pL = \pi DL$$

$$\dot{Q} = hA_s(T_s - T_\infty)$$

6. a) A metal plate 0.609 m high forms the vertical wall of an oven and is at a temperature of 161 °C. Within the oven air at a temperature of 93 °C and one atmosphere. Assuming that natural convection conditions hold near the plate, estimate the mean heat transfer coefficient and rate of heat transfer per unit width of the plate.

$$Ra_L = \frac{g\beta(T_s - T_\infty)L^3}{\nu^2} Pr$$

$$Nu = \left\{ 0.825 + \frac{0.387 Ra_L^{1/6}}{[1 + (0.492/Pr)^{9/16}]^{8/27}} \right\}^2$$

$$h = \frac{k}{L} Nu$$

Find surface area

$A_s$

$$\dot{Q} = hA_s(T_s - T_\infty)$$

b) A 10 mm diameter spherical steel ball at 260°C is immersed in air at 90°C. Estimate the rate of convective heat loss. [NOV DEC 14]

$$Ra_L = \frac{g\beta(T_s - T_\infty)L^3}{\nu^2} Pr$$

**Use Nusselt no for spherical configuration**

$$h = \frac{k}{L} Nu$$

**Find surface area of sphere and calculate rate of heat loss**

$$\dot{Q} = hA_s(T_s - T_\infty)$$

7. Engine oil flows through a 50 mm diameter tube at an average temperature of 147°C. The flow velocity is 80 cm/s. Calculate the average heat transfer coefficient if the tube wall is maintained at a temperature of 200°C and it is 2 m long.

**Given :** Diameter  $D = 50 \text{ mm} = 0.050 \text{ m}$

Average temperature  $T_m = 147^\circ\text{C}$

Velocity  $U = 80 \text{ cm/s} = 0.80 \text{ m/s}$

Tube wall temperature  $T_w = 200^\circ\text{C}$

Length  $L = 2 \text{ m}$

**To find:** Average heat transfer coefficient ( $h$ )

**Solution :** Properties of engine oil at 147°C

$$\rho = 816 \text{ Kg/m}^3$$

$$\nu = 7 \times 10^{-6} \text{ m}^2/\text{s}$$

$$\text{Pr} = 116$$

$$K = 133.8 \times 10^{-3} \text{ W/mK}$$

We know

$$\text{Reynolds number } Re = \frac{UD}{\nu}$$

$$= \frac{0.8 \times 0.05}{7 \times 10^{-6}}$$

$$Re = 5714.2$$

Since  $Re < 2300$  flow is turbulent

$$\frac{L}{D} = \frac{2}{0.050} = 40$$

$$10 < \frac{L}{D} < 400$$

For turbulent flow, ( $Re < 10000$ )

$$\text{Nusselt number } Nu = 0.036 (Re)^{0.8} (\text{Pr})^{0.33} \left(\frac{D}{L}\right)^{0.055}$$

$$Nu = 0.036 (5714.2)^{0.8} \times (116)^{0.33} \times \left(\frac{0.050}{2}\right)^{0.055}$$

$$Nu = 142.8$$

$$\text{We know } Nu = \frac{hD}{K}$$

$$\Rightarrow 142.8 = \frac{h \times 0.050}{133.8 \times 10^{-3}}$$

$$\Rightarrow h = 382.3 \text{ W/m}^2\text{K}$$

8. A thin 100 cm long and 10 cm wide horizontal plate is maintained at a uniform temperature of  $150^\circ\text{C}$  in a large tank full of water at  $75^\circ\text{C}$ . Estimate the rate of heat to be supplied to the plate to maintain constant plate temperature as heat is dissipated from either side of plate.

**Given :**



Length of horizontal plate  $L = 100 \text{ cm} = 1 \text{ m}$

Wide  $W = 10 \text{ cm} = 0.10 \text{ m}$

Plate temperature  $T_w = 150^\circ\text{C}$

Fluid temperature  $T_\infty = 75^\circ\text{C}$

**To find:** Heat loss (Q) from either side of plate

$$\text{Film temperature } T_f = \frac{T_w - T_\infty}{2}$$
$$= \frac{150 + 75}{2}$$

$$T_f = 112.5^\circ\text{C}$$

Properties of water at  $112.5^\circ\text{C}$

$$\rho = 951 \text{ Kg/m}^3$$

$$\nu = 0.264 \times 10^{-6} \text{ m}^2/\text{s}$$

$$\text{Pr} = 1.55$$

$$K = 683 \times 10^{-3} \text{ W/mK}$$

$$\text{Coefficient of thermal expansion } \beta = \frac{1}{T_f \text{ in K}} = \frac{1}{112.5 + 273}$$

$$\beta = 2.59 \times 10^{-3} \text{ K}^{-1}$$

$$\text{Grashof Number } Gr = \frac{g \times \beta \times L^3 \times \Delta T}{\nu^2}$$

For horizontal plate,

$$\text{Characteristic length } L_c = \frac{W}{2} = \frac{0.10}{2}$$

$$L_c = 0.05 \text{ m}$$

$$(1) \Rightarrow Gr = \frac{9.81 \times 2.59 \times 10^{-3} \times (0.05)^3 \times (150 - 75)}{(0.264 \times 10^{-6})^2}$$

$$Gr = 3.41 \times 10^9$$

$$Gr \text{ Pr} = 3.41 \times 10^9 \times 1.55$$

$$Gr \text{ Pr} = 5.29 \times 10^9$$

Gr Pr value is in between  $8 \times 10^6$  and  $10^{11}$

i.e.,  $8 \times 10^6 < Gr Pr < 10^{11}$

**For horizontal plate, upper surface heated:**

Nusselt number  $Nu = 0.15 (Gr Pr)^{0.333}$

$$\Rightarrow Nu = 0.15 [5.29 \times 10^9]^{0.333}$$

$$\Rightarrow Nu = 259.41$$

We know that,

$$\text{Nusselt number } Nu = \frac{h_u L_c}{K}$$

$$259.41 = \frac{h_u \times 0.05}{683 \times 10^{-3}}$$

$$h_u = 3543.6 \text{ W/m}^2\text{K}$$

Upper surface heated, heat transfer coefficient  $h_u = 3543.6 \text{ W/m}^2\text{K}$

**For horizontal plate, lower surface heated:**

Nusselt number  $Nu = 0.27 [Gr Pr]^{0.25}$

$$\Rightarrow Nu = 0.27 [5.29 \times 10^9]^{0.25}$$

$$Nu = 72.8$$

We know that,

$$\text{Nusselt number } Nu = \frac{h_l L_c}{K}$$

$$72.8 = \frac{h_l L_c}{K}$$

$$72.8 = \frac{h_l \times 0.05}{683 \times 10^{-3}}$$

$$h_l = 994.6 \text{ W/m}^2\text{K}$$

Lower surface heated, heat transfer coefficient  $h_l = 994.6 \text{ W/m}^2\text{K}$

Total heat transfer  $Q = (h_u + h_l) \times A \times \Delta T$

$$\begin{aligned} &= (h_u + h_f) \times W \times L \times (T_w - T_\infty) \\ &= (3543.6 + 994.6) \times 0.10 \times (150 - 75) \\ Q &= 34036.5 \text{ W} \end{aligned}$$

9. a) Explain in detail about boundary layer concept.

Refer q.no 5a

- b) An aeroplane flies with a speed of 450 km/h at a height where the surrounding air has a temperature of 1°C and pressure of 65 cm of Hg. The aeroplane wing idealized as a flat plate 6m long, 1.2m wide is maintained at 19 °C. If the flow is made parallel to the 1.2 m width calculate 1) Heat loss from the wing 2) Drag force on the wing. [NOV- DEC 13]

$$Re_L = \frac{\rho V L}{\mu}$$

$$C_f = 1.328 Re_L^{-0.5}$$

$$F_D = C_f A_s \frac{\rho V^2}{2}$$

$$Nu = \frac{hL}{k} = 0.664 Re_L^{0.5} Pr^{1/3}$$

$$h = \frac{k}{L} Nu$$

$$\dot{Q} = hA_s(T_\infty - T_s)$$

10. Explain development of hydrodynamic and thermal boundary layers with suitable figure and solve the following.

In a straight tube of 50mm diameter, water is flowing at 15 m/s. The tube surface temperature is maintained at 60°C and the flowing water is heated from the inlet temperature 15 °C to an outlet temperature of 45°C. Calculate the heat transfer coefficient from the tube surface to the water and length of the tube. [MAY-JUN 14]

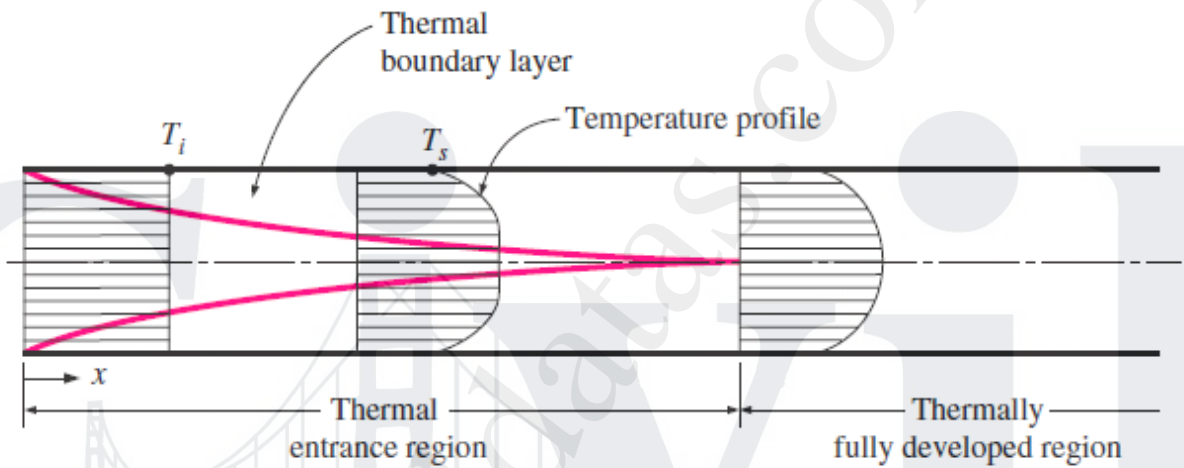
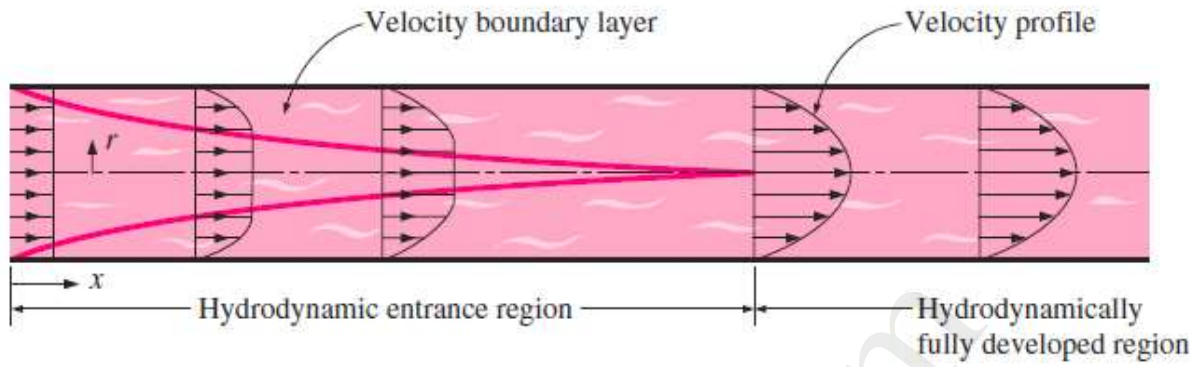

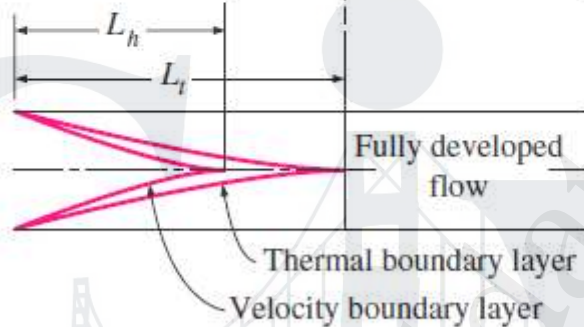
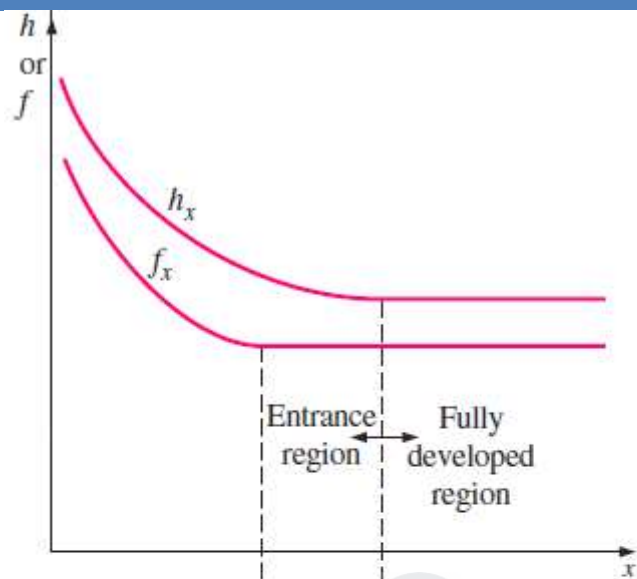

Variation of the friction factor and the convection heat transfer coefficient in the flow

$$\dot{Q} = \dot{m} C_p (T_e - T_i)$$

$$\Delta T_{\ln} = \frac{\Delta T_e - \Delta T_i}{\ln(\Delta T_e / \Delta T_i)}$$

Find h using the following expression

$$Nu = \frac{hD}{k} = 3.66$$

$$\dot{Q} = hA_s \Delta T_{\ln}$$

$$A_s = \frac{\dot{Q}}{h\Delta T_{ln}}$$

$$L = \frac{A_s}{\pi D}$$

11. A two stroke motor cycle petrol engine cylinder consists of 15 annular fins. If outside and inside diameters of each fin are 200 mm and 100 mm respectively. The average fin surface temperature is 475 °C and they are exposed in air at 25 °C. Calculate the heat transfer rate from the fins for the following condition (i) When motor cycle is at rest. (ii) when motor cycle is running at a speed of 60 km/h. The fin may be idealized as a single horizontal flat plate of same area. [NOV - DEC 13]

Refer unit 1 fin problems 9, 10, 11 along with Rayleigh no and Nusselt no for free and forced convection

## UNIT-3 PHASE CHANGE HEAT TRANSFER AND HEAT EXCHANGERS

### PART-A

#### 1. What is meant by Boiling and condensation?

The change of phase from liquid to vapour state is known as boiling.

The change of phase from vapour to liquid state is known as condensation.

#### 2. Give the applications of boiling and condensation.

Boiling and condensation process finds wide applications as mentioned below.

1. Thermal and nuclear power plant.
2. Refrigerating systems
3. Process of heating and cooling
4. Air conditioning systems

#### 3. What is meant by pool boiling? [NOV DEC 14]

If heat is added to a liquid from a submerged solid surface, the boiling process referred to as pool boiling. In this case the liquid above the hot surface is essentially stagnant and its motion near the surface is due to free convection and mixing induced by bubble growth and detachment.

**4. What is meant by Film wise and Drop wise condensation?**

The liquid condensate wets the solid surface, spreads out and forms a continuous film over the entire surface is known as film wise condensation.

In drop wise condensation the vapour condenses into small liquid droplets of various sizes which fall down the surface in a random fashion.

**5. Give the merits of drop wise condensation?**

In drop wise condensation, a large portion of the area of the plate is directly exposed to vapour. The heat transfer rate in drop wise condensation is 10 times higher than in film condensation.

**6. What is heat exchanger?**

A heat exchanger is defined as an equipment which transfers the heat from a hot fluid to a cold fluid.

**7. What are the types of heat exchangers?**

The types of heat exchangers are as follows

1. Direct contact heat exchangers
2. Indirect contact heat exchangers
3. Surface heat exchangers
4. Parallel flow heat exchangers
5. Counter flow heat exchangers
6. Cross flow heat exchangers
7. Shell and tube heat exchangers
8. Compact heat exchangers.

**8. What is meant by direct heat exchanger (or) open heat exchanger?**

In direct contact heat exchanger, the heat exchange takes place by direct mixing of hot and cold fluids.

**9. What is meant by indirect contact heat exchanger?**

In this type of heat exchangers, the transfer of heat between two fluids could be carried out by transmission through a wall which separates the two fluids.

**10. What is meant by Regenerators?**

In this type of heat exchangers, hot and cold fluids flow alternately through the same space.  
Examples: IC engines, gas turbines.

**11. What is meant by Recuperater (or) surface heat exchangers?**

This is the most common type of heat exchangers in which the hot and cold fluid do not come into direct contact with each other but are separated by a tube wall or a surface.

**12. What is meant by parallel flow and counter flow heat exchanger?**

In this type of heat exchanger, hot and cold fluids move in the same direction.

In this type of heat exchanger hot and cold fluids move in parallel but opposite directions.

**13. What is meant by shell and tube heat exchanger?**

In this type of heat exchanger, one of the fluids move through a bundle of tubes enclosed by a shell. The other fluid is forced through the shell and it moves over the outside surface of the tubes.

**14. What is meant by compact heat exchangers?**

There are many special purpose heat exchangers called compact heat exchangers. They are generally employed when convective heat transfer coefficient associated with one of the fluids is much smaller than that associated with the other fluid.

**15. What is meant by LMTD?**

We know that the temperature difference between the hot and cold fluids in the heat exchanger varies from point in addition various modes of heat transfer are involved. Therefore based on concept of appropriate mean temperature difference, also called logarithmic mean temperature difference, also called logarithmic mean temperature difference, the total heat transfer rate in the heat exchanger is expressed as

$$Q = U A (\Delta T)_m \text{ Where } U - \text{Overall heat transfer coefficient } W/m^2K \quad A - \text{Area } m^2$$

$(\Delta T)_m$  – Logarithmic mean temperature difference.

**16. What is meant by Fouling factor?**

We know the surfaces of a heat exchangers do not remain clean after it has been in use for some time. The surfaces become fouled with scaling or deposits. The effect of these deposits the value of overall heat transfer coefficient. This effect is taken care of by introducing an additional thermal resistance called the fouling resistance.

**17. What is meant by effectiveness? [NOV DEC 14]**

The heat exchanger effectiveness is defined as the ratio of actual heat transfer to the maximum possible heat transfer.

$$\text{Effectiveness } \varepsilon = \frac{\text{Actual heat transfer}}{\text{Maximum possible heat transfer}} = \frac{Q}{Q_{\max}}$$

**18. Distinguish the pool boiling from forced convection boiling. [NOV-DEC 13]**

Boiling is called pool boiling in the absence of bulk fluid flow, and flow boiling (or forced convection boiling) in the presence of it.

In pool boiling, the fluid is stationary, and any motion of the fluid is due to natural convection currents and the motion of the bubbles due to the influence of buoyancy.

**19. What are the limitations of LMTD method? How is  $\varepsilon$ -NTU method superior to LMTD method? [NOV-DEC 13]**

The LMTD cannot be used for determination of heat transfer rate and the outlet temperature of the hot and cold fluids for prescribed fluid mass flow rates and inlet temperatures when type and size of heat exchanger are specified.

Effectiveness NTU is superior for the above case because LMTD requires tedious iterations for the same.

**20. Write down the relation for overall heat transfer coefficient in heat exchanger with fouling factor. [MAY-JUN 13]**

Overall heat transfer coefficient in heat exchanger

$$\frac{1}{U_o A_o} = R = \frac{1}{h_i A_i} + \frac{R_{f,i}}{A_i} + \frac{\ln\left(\frac{D_o}{D_i}\right)}{2\pi k L} + \frac{R_{f,o}}{A_o} + \frac{1}{h_o A_o}$$

Where  $A_i = \pi D_i L$  and  $A_o = \pi D_o L$  are the areas of inner and outer surfaces, and  $R_{f,i}$  and  $R_{f,o}$  are the fouling factors at those surfaces.

**21. What are the different regimes involved in pool boiling? [MAY-JUN 13]**

Four different boiling regimes are observed in pool boiling they are natural convection boiling, nucleate boiling, transition boiling, and film boiling

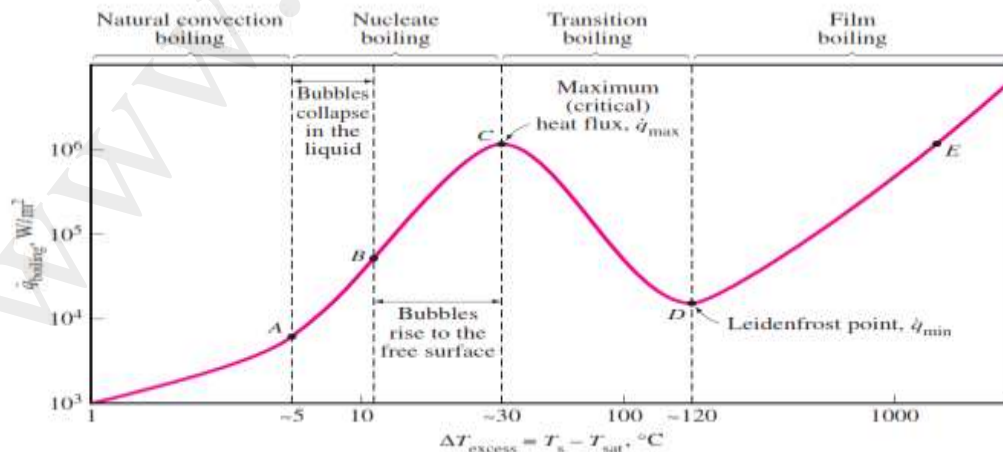



**22. What is boiling? What mechanisms are responsible for the very high heat transfer coefficients in nucleate boiling?**

Boiling is the liquid-to-vapor phase change process that occurs at a solid-liquid interface when the surface is heated above the saturation temperature of the liquid. The formation and rise of the bubbles and the liquid entrainment coupled with the large amount of heat absorbed during liquid-vapor phase change at essentially constant temperature are responsible for the very high heat transfer coefficients associated with nucleate boiling.

**23. What is the difference between evaporation and boiling?**

Both boiling and evaporation are liquid-to-vapor phase change processes, but evaporation occurs at the liquid-vapor interface when the vapor pressure is less than the saturation pressure of the liquid at a given temperature, and it involves no bubble formation or bubble motion. Boiling, on the other hand, occurs at the solid-liquid interface when a liquid is brought into contact with a surface maintained at a temperature  $T_s$  sufficiently above the saturation temperature  $T_{sat}$  of the liquid.

**24. What is condensation? How does it occur?**

Condensation is a vapor-to-liquid phase change process. It occurs when the temperature of a vapor is reduced below its saturation temperature  $T_{sat}$ . This is usually done by bringing the vapor into contact with a solid surface whose temperature  $T_s$  is below the saturation temperature  $T_{sat}$  of the vapor.

**PART B**

1. Water is boiled at the rate of 24 kg/h in a polished copper pan, 300 mm in diameter, at atmospheric pressure. Assuming nucleate boiling conditions calculate the temperature of the bottom surface of the pan.

**Given :**

$$m = 24 \text{ kg / h}$$
$$= \frac{24 \text{ kg}}{3600 \text{ s}}$$

$$m = 6.6 \times 10^{-3} \text{ kg/s}$$

$$d = 300 \text{ mm} = .3\text{m}$$

**Solution:**

We know saturation temperature of water is  $100^\circ\text{C}$

i.e.  $T_{sat} = 100^\circ\text{C}$

Properties of water at  $100^\circ\text{C}$

From HMT data book Page No.13

$$\text{Density } \rho_l = 961 \text{ kg/m}^3$$

$$\text{Kinematic viscosity } \nu = 0.293 \times 10^{-6} \text{ m}^2/\text{s}$$

$$\text{Prandtl number } P_r = 1.740$$

$$\text{Specific heat } C_{pl} = 4.216 \text{ kJ/kg K} = 4216 \text{ J/kg K}$$

$$\begin{aligned} \text{Dynamic viscosity } \mu_l &= \rho_l \times \nu \\ &= 961 \times 0.293 \times 10^{-6} \end{aligned}$$

$$\boxed{\mu_l = 281.57 \times 10^{-6} \text{ Ns/m}^2}$$

From steam table (R.S. Khumi Steam table Page No.4)  
At 100°C

$$\text{Enthalpy of evaporation } h_{fg} = 2256.9 \text{ kJ/kg}$$

$$\boxed{h_{fg} = 2256.9 \times 10^3 \text{ J/kg}}$$

Specific volume of vapour

$$V_g = 1.673 \text{ m}^3/\text{kg}$$

Density of vapour

$$\rho_v = \frac{1}{v_g}$$

$$\frac{1}{1.673}$$

$$\boxed{\rho_v = 0.597 \text{ kg/m}^3}$$

For nucleate boiling

$$\text{Heat flux } \frac{Q}{A} = \mu_l \times h_{fg} \left| \frac{g \times (\rho_l - \rho_v)}{\sigma} \right| \times \left| \frac{C_{pl} \times \Delta T}{C_{sf} \times h_{fg} P_r^{1.7}} \right|^3$$

We know transferred  $Q = m \times h_{fg}$

Heat transferred  $Q = m \times h_{fg}$ .

$$\frac{Q}{A} = \frac{m h_{fg}}{A}$$

$$\frac{Q}{A} = \frac{6.6 \times 10^{-3} \times 2256.9 \times 10^3}{\frac{\pi d^2}{4}}$$

$$= \frac{6.6 \times 10^{-3} \times 2256.9 \times 10^3}{\frac{\pi (.3)^2}{4}}$$

$$\boxed{\frac{Q}{A} = 210 \times 10^3 \text{ W/m}^2}$$

$\sigma$  = surface tension for liquid vapour interface

At 100°C (From HMT data book Page No.147)

$$\sigma = 58.8 \times 10^{-3} \text{ N/m}$$

For water – copper – Csf = Surface fluid constant = 013

$$C_{sf} = .013 \quad (\text{From HMT data book Page No.145})$$

Substitute,  $\mu$ ,  $h_{fg}$ ,  $\rho_l$ ,  $\rho_v$ ,  $\sigma$ , Cpl, hfg,  $\frac{Q}{A}$  and  $P_r$  values in Equation (1)

$$(1) \Rightarrow 210 \times 10^3 = 281.57 \times 10^{-6} \times 2256.9 \times 10^3$$

$$\left| \frac{9.81 \times 961 - 597}{58.8 \times 10^{-3}} \right|^{0.5}$$

$$\left| \frac{4216 \times \Delta T}{.013 \times 2256.9 \times 10^3 \times (1.74)^{1.7}} \right|^3$$

$$\Rightarrow \left| \frac{4216 \times \Delta T}{75229.7} \right| = 0.825$$

$$\Rightarrow \Delta T (.56)^3 = .825$$

$$\Rightarrow \Delta T \times .056 = 0.937$$

$$\Delta T - 16.7$$

We know that

$$\text{Excess temperature } \Delta T = T_w - T_{sat}$$

$$16.7 = T_w - 100^\circ\text{C}.$$

$$T_w = 116.7^\circ\text{C}$$

2. i) Explain about fouling factors.

## Fouling Factor

Considerable effort has been directed during the past decade toward the understanding of fouling. During operation, heat exchangers become fouled with an accumulation of deposits of one kind or another on heat transfer surfaces. As a result, the thermal resistance in the path of heat flow increases, which reduces the heat transfer rate. The economic penalty for fouling can be attributed to

1. Higher capital expenditure through oversized units
2. Energy losses due to thermal inefficiencies
3. Costs associated with periodic cleaning of heat exchangers
4. Loss of production during shutdown for cleaning

following six categories of fouling:

1. *Scaling or precipitation fouling*, the crystallization from solution of dissolved substance onto the heat transfer surface
2. *Particulate fouling*, the accumulation of finely divided solids suspended in the process fluid onto the heat transfer surface
3. *Chemical reaction fouling*, the deposit formation on the heat transfer surface by chemical reaction
4. *Corrosion fouling*, the accumulation of corrosion products on the heat transfer surface
5. *Biological fouling*, the attachment of microorganisms to a heat transfer surface
6. *Solidification fouling*, the crystallization of a pure liquid or one component from the liquid phase on a subcooled heat transfer surface

ii) Hot oil with a capacity rate of 2500 W/K flows through a double pipe heat exchanger. It enters at 360 °C and leaves at 300 °C. Cold fluid enters at 30 °C and leaves at 200 °C. If the overall heat transfer coefficient is 800 W/m<sup>2</sup>K, determine the heat exchanger area required for 1) parallel flow and 2) Counter flow. [NOV DEC 14]

heat capacity rate  $C_h = 2500 \text{ W/K}$

$U = 800 \text{ W/m}^2\text{K}$

$T_{hi} = 360 \text{ }^\circ\text{C}$ ,  $T_{ho} = 300 \text{ }^\circ\text{C}$

$T_{ci} = 30 \text{ }^\circ\text{C}$   $T_{co} = 200 \text{ }^\circ\text{C}$

Find  $A = ?$

$Q = U A (\text{LMTD})$

Also  $Q_{\text{hot fluid}} = C_h \cdot \Delta T = 150000 \text{ W}$

Calculate  $\text{Lmtd}$  for parallel and counter flow

LMTD for parallel flow = 192.64 K

LMTD for counter flow = 210.2 K

the heat exchanger area required for

1) parallel flow

$$A = 0.973 \text{ m}^2$$

2) Counter flow

$$A = 0.892 \text{ m}^2$$

3. a) A vertical tube of 50 mm outside diameter and 2 m long is exposed to steam at atmospheric pressure. The outer surface of the tube is maintained at a temperature of 84 °C by circulating cold water through the tube. Determine the rate of heat transfer and also the condensate mass flow rate.

[NOV DEC 14]

Properties at film temperature  $80+100/2 = 90 \text{ C}$

$$\rho_l = 965.3 \text{ kg/m}^3$$

$$\mu_l = 0.315 \times 10^{-3} \text{ kg/m} \cdot \text{s}$$

$$\nu_l = \mu_l / \rho_l = 0.326 \times 10^{-6} \text{ m}^2/\text{s}$$

$$C_{pl} = 4206 \text{ J/kg} \cdot \text{°C}$$

$$k_l = 0.675 \text{ W/m} \cdot \text{°C}$$

The modified latent heat vaporization

$$h_{fg}^* = h_{fg} + 0.68 C_{pl} (T_{\text{sat}} - T_s)$$

$$H_{fg} = 2314 \times 10^3 \text{ J/kg}$$

$$\text{Re} = 1287$$

$$h = 5848 \text{ W/m}^2 \text{ K}$$

$$\dot{Q} = h A_s (T_{\text{sat}} - T_s)$$

$$A_s = 0.31416 \text{ m}^2$$

$$Q = 36.7 \text{ kW}$$

$$\dot{m}_{\text{condensation}} = \frac{\dot{Q}}{h_{fg}^*}$$

$$m = 0.0158 \text{ kg/s}$$

4. A Nickel wire carrying electric current of 1.5 mm diameter and 50 cm long, is submerged in a water bath which is open to atmospheric pressure. Calculate the voltage at the burn out point, if at this point the wire carries a current of 200A.

**Given :**

$$D = 1.5\text{mm} = 1.5 \times 10^{-3} \text{ m}; L = 50 \text{ cm} = 0.50\text{m}; \text{Current } I = 200\text{A}$$

**Solution**

We know saturation temperature of water is 100°C  
i.e.  $T_{\text{sat}} = 100^\circ\text{C}$

Properties of water at 100°C  
(From HMT data book Page No.11)

$$\rho_l = 961 \text{ kg/m}^3$$

$$\nu = 0.293 \times 10^{-6} \text{ m}^2 / \text{s}$$

$$Pr = 1.740$$

$$Cpl = 4.216 \text{ kJ/kg K} = 4216 \text{ J/kg K}$$

$$\mu_l = \rho_l \times \nu = 961 \times 0.293 \times 10^{-6}$$

$$\mu_l = 281.57 \times 10^{-6} \text{ Ns/m}^2$$

From steam Table at 100°C

R.S. Khurmi Steam table Page No.4

$$h_{fg} = 2256.9 \text{ kJ/kg}$$

$$h_{fg} = 2256.9 \times 10^3 \text{ J/kg}$$

$$\nu_g = 1.673 \text{ m}^3 / \text{kg}$$

$$\rho_v = \frac{1}{\nu_g} = \frac{1}{1.673} = 0.597 \text{ kg/m}^3$$

$\sigma$  = Surface tension for liquid – vapour interface  
At 100°C

$$\sigma = 58.8 \times 10^{-3} \text{ N/m} \text{ (From HMT data book Page No.147)}$$

For nucleate pool boiling critical heat flux (AT burn out)

$$\frac{Q}{A} = 0.18 \times h_{fg} \times \rho v \left[ \frac{\sigma \times g \times (\rho l - \rho v)^{0.25}}{\rho v^2} \right] \text{---1}$$

(From HMT data book Page No.142)

Substitute  $h_{fg}$ ,  $\rho l$ ,  $\rho v$ ,  $\sigma$  values in Equation (1)

$$(1) \Rightarrow \frac{Q}{A} = 0.18 \times 2256.9 \times 10^3 \times 0.597$$

$$\left[ \frac{58.8 \times 10^{-3} \times 9.81 (961 - .597)}{.597^2} \right]^{0.25}$$

$$\boxed{\frac{Q}{A} = 1.52 \times 10^6 \text{ W/m}^2}$$

We know

Heat transferred  $Q = V \times I$

$$\frac{Q}{A} = \frac{V \times I}{A}$$

$$1.52 \times 10^6 = \frac{V \times 200}{\pi d L} \quad \therefore A = \pi d L$$

$$1.52 \times 10^6 = \frac{V \times 200}{\pi \times 1.5 \times 10^{-3} \times .50}$$

$$\boxed{V = 17.9 \text{ volts}}$$

5. Water is boiling on a horizontal tube whose wall temperature is maintained at  $15^\circ\text{C}$  above the saturation temperature of water. Calculate the nucleate boiling heat transfer coefficient. Assume the water to be at a pressure of 20 atm. And also find the change in value of heat transfer coefficient when
- The temperature difference is increased to  $30^\circ\text{C}$  at a pressure of 10 atm.
  - The pressure is raised to 20 atm at  $\Delta T = 15^\circ\text{C}$

**Given :**

Wall temperature is maintained at  $15^\circ\text{C}$  above the saturation temperature.

$$T_w = 115^\circ\text{C}. \quad \therefore T_{\text{sat}} = 100^\circ\text{C} \quad T_w = 100 + 15 = 115^\circ\text{C}$$

$$= p = 10 \text{ atm} = 10 \text{ bar}$$

case (i)

$$\Delta T = 30^\circ\text{C}; p = 10 \text{ atm} = 10 \text{ bar}$$

case (ii)

$$p = 20 \text{ atm} = 20 \text{ bar}; \Delta T = 15^\circ\text{C}$$

**Solution:**

We know that for horizontal surface, heat transfer coefficient

$$h = 5.56 (\Delta T)^3 \text{ From HMT data book Page No.128}$$
$$h = 5.56 (T_w - T_{sat})^3$$
$$= 5.56 (115 - 100)^3$$

$$h = 18765 \text{ w/m}^2\text{K}$$

Heat transfer coefficient other than atmospheric pressure

$$h_p = hp^{0.4} \text{ From HMT data book Page No.144}$$
$$= 18765 \times 10^{0.4}$$

$$\text{Heat transfer coefficient } h_p = 47.13 \times 10^3 \text{ W/m}^2\text{K}$$

**Case (i)**

$P = 100 \text{ bar } \Delta T = 30^\circ\text{C}$  From HMT data book Page No.144

Heat transfer coefficient

$$h = 5.56 (\Delta T)^3 = 5.56(30)^3$$

$$h = 150 \times 10^3 \text{ W/m}^2\text{K}$$

Heat transfer coefficient other than atmospheric pressure

$$h_p = hp^{0.4}$$
$$= 150 \times 10^3 (10)^{0.4}$$

$$h_p = 377 \times 10^3 \text{ W/m}^2\text{K}$$

**Case (ii)**

$P = 20 \text{ bar; } \Delta T = 15^\circ\text{C}$

Heat transfer coefficient  $h = 5.56 (\Delta T)^3 = 5.56 (15)^3$

$$h = 18765 \text{ W/m}^2\text{K}$$

Heat transfer coefficient other than atmospheric pressure

$$h_p = hp^{0.4}$$
$$= 18765 (20)^{0.4}$$

$$h_p = 62.19 \times 10^3 \text{ W/m}^2\text{K}$$

6. A vertical flat plate in the form of fin is 500m in height and is exposed to steam at atmospheric pressure. If surface of the plate is maintained at  $60^\circ\text{C}$ . calculate the following.



- i) The film thickness at the trailing edge
  - ii). Overall heat transfer coefficient
  - iii). Heat transfer rate
  - iv). The condensate mass flow rate.
- Assume laminar flow conditions and unit width of the plate.

**Given :**

Height ore length  $L = 500 \text{ mm} = 5\text{m}$

Surface temperature  $T_w = 60^\circ\text{C}$

**Solution**

We know saturation temperature of water is  $100^\circ\text{C}$

i.e.  $T_{\text{sat}} = 100^\circ\text{C}$

(From R.S. Khurmi steam table Page No.4

$$h_{fg} = 2256.9\text{kJ/kg}$$

$$h_{fg} = 2256.9 \times 10^3 \text{ j/kg}$$

We know

$$\text{Film temperature } T_f = \frac{T_w + T_{\text{sat}}}{2}$$

$$= \frac{60 + 100}{2}$$

$$T_f = 80^\circ\text{C}$$

Properties of saturated water at  $80^\circ\text{C}$

(From HMT data book Page No.13)

$$\rho = 974 \text{ kg/m}^3$$

$$\nu = 0.364 \times 10^{-6} \text{ m}^2/\text{s}$$

$$k = 668.7 \times 10^{-3} \text{ W/mk}$$

$$\mu = \rho \times \nu = 974 \times 0.364 \times 10^{-6}$$

$$\mu = 354.53 \times 10^{-6} \text{ Ns/m}^2$$

1. Film thickness  $\delta_x$

We know for vertical plate

Film thickness

$$\delta_x = \left( \frac{4\mu K \times x \times (T_{\text{sat}} - T_w)}{g \times h_{fg} \times \rho^2} \right)^{0.25}$$

Where

$$X = L = 0.5 \text{ m}$$

$$\delta_x = \frac{4 \times 354.53 \times 10^{-6} \times 668.7 \times 10^{-3} \times 0.5 \times 100 - 60}{9.81 \times 2256.9 \times 10^3 \times 974^2}$$
$$\delta_x = 1.73 \times 10^{-4} \text{ m}$$

2. Average heat transfer coefficient (h)

For vertical surface Laminar flow

$$h = 0.943 \left[ \frac{k_3 \times \rho^2 \times g \times h_{fg}}{\mu \times L \times T_{\text{sat}} - T_w} \right]^{0.25}$$

The factor 0.943 may be replaced by 1.13 for more accurate result as suggested by Mc Adams

$$1.13 \left( \frac{(668.7 \times 10^{-3})^3 \times (974)^2 \times 9.81 \times 2256.9 \times 10^3}{354.53 \times 10^{-6} \times 1.5 \times 100 - 60} \right)^{0.25}$$

$$h = 6164.3 \text{ W/m}^2\text{k.}$$

3. Heat transfer rate Q

We know

$$\begin{aligned} Q &= hA(T_{\text{sat}} - T_w) \\ &= h \times L \times W \times (T_{\text{sat}} - T_w) \\ &= 6164.3 \times 0.5 \times 1 \times 100 - 60 \end{aligned}$$

$$Q = 123286 \text{ W}$$

4. Condensate mass flow rate m

We know

$$Q = m \times h_{fg}$$

$$m = \frac{Q}{h_{fg}}$$

$$m = \frac{123286}{2256.9 \times 10^3}$$

$$m = 0.054 \text{ kg/s}$$

7. A condenser is to design to condense 600 kg/h of dry saturated steam at a pressure of 0.12 bar. A square array of 400 tubes, each of 8 mm diameters is to be used. The tube surface is maintained at 30°C. Calculate the heat transfer coefficient and the length of each tube.

**Given :**

$$m = 600 \text{ kg/h} = \frac{600}{3600} \text{ kg/s} = 0.166 \text{ kg/s}$$

$$m = 0.166 \text{ kg/s}$$

Pressure  $P = 0.12 \text{ bar}$  No. of tubes = 400

$$\text{Diameter } D = 8 \text{ mm} = 8 \times 10^{-3} \text{ m}$$

$$\text{Surface temperature } T_w = 30^\circ\text{C}$$

### Solution

Properties of steam at 0.12 bar From R.S. Khurmi steam table Page No.7

$$T_{\text{sat}} = 49.45^\circ\text{C}$$

$$h_{\text{fg}} = 2384.3 \text{ kJ/kg}$$

$$h_{\text{fg}} = 2384.9 \times 10^3 \text{ J/kg}$$

We know

$$\text{Film temperature } T_f = \frac{T_w + T_{\text{sat}}}{2}$$

$$= \frac{30 + 49.45}{2}$$

$$T_f = 39.72^\circ\text{C} = 40^\circ\text{C}$$

Properties of saturated water at 40°C

From HMT data book Page No.13

$$\rho = 995 \text{ kg/m}^3$$

$$\nu = .657 \times 10^{-6} \text{ m}^2/\text{s}$$

$$k = 628.7 \times 10^{-3} \text{ W/mk}$$

$$\mu = \rho \times \nu = 995 \times 0.657 \times 10^{-6}$$

$$\mu = 653.7 \times 10^{-6} \text{ Ns/m}^2$$

with 400 tubes a  $20 \times 20$  tube of square array could be formed

$$\text{i.e. } N = \sqrt{400} = 20$$

$$N = 20$$

For horizontal bank of tubes heat transfer coefficient.

$$h = 0.728 \left[ \frac{K^3 \rho^2 g h_{fg}}{\mu D (T_{sat} - T_w)} \right]^{0.25}$$

From HMT data book Page No.150

$$h = 0.728 \left[ \frac{(628 \times 10^{-3})^3 \times (995)^2 \times 9.81 \times 2384.3 \times 10^3}{653.7 \times 10^{-6} \times 20 \times 8 \times 10^{-3} \times (49.45 - 30)} \right]^{0.25}$$

$$h = 5304.75 \text{ W/m}^2\text{K}$$

We know

Heat transfer

$$Q = hA(T_{sat} - T_w)$$

No. of tubes = 400

$$Q = 400 \times h \times \pi \times D \times L \times (T_{sat} - T_w)$$

$$Q = 400 \times 5304.75 \times \pi \times 8 \times 10^{-3} \times 1 \times (49.45 - 30)$$

$$Q = 1.05 \times 10^6 \times L \dots\dots 1$$

We know

$$Q = m \times h_{fg}$$

$$= 0.166 \times 2384.3 \times 10^3$$

$$Q = 0.3957 \times 10^6 \text{ W}$$

$$= 0.3957 \times 10^6 = 1.05 \times 10^6 L$$

$$L = 0.37 \text{ m}$$

8. Steam at 0.080 bar is arranged to condense over a 50 cm square vertical plate. The surface temperature is maintained at 20°C. Calculate the following.
- Film thickness at a distance of 25 cm from the top of the plate.
  - Local heat transfer coefficient at a distance of 25 cm from the top of the plate.
  - Average heat transfer coefficient.
  - Total heat transfer
  - Total steam condensation rate.

What would be the heat transfer coefficient if the plate is inclined at 30° with horizontal plane.

**Given :**

Pressure P = 0.080 bar

Area A = 50 cm × 50 cm = 50 × 050 = 0.25 m<sup>2</sup>

Surface temperature  $T_w = 20^\circ\text{C}$

Distance  $x = 25 \text{ cm} = .25 \text{ m}$

### Solution

Properties of steam at 0.080 bar

(From R.S. Khurmi steam table Page no.7)

$$T_{\text{satj/kg}} = 41.53^\circ\text{C}$$

$$h_{\text{fg}} = 2403.2 \text{ kJ/kg} = 2403.2 \times 10^3 \text{ J/kg}$$

We know

$$\text{Film temperature } T_f = \frac{T_w + T_{\text{sat}}}{2}$$

$$= \frac{20 + 41.53}{2}$$

$$T_f = 30.76^\circ\text{C}$$

Properties of saturated water at  $30.76^\circ\text{C} = 30^\circ\text{C}$

From HMT data book Page No.13

$$\rho = 997 \text{ kg/m}^3$$

$$\nu = 0.83 \times 10^{-6} \text{ m}^2/\text{s}$$

$$k = 612 \times 10^{-3} \text{ W/mK}$$

$$\mu = \rho \times \nu = 997 \times 0.83 \times 10^{-6}$$

$$\mu = 827.51 \times 10^{-6} \text{ Ns/m}^2$$

a. Film thickness

We know for vertical surfaces

$$\delta x = \left( \frac{4\mu K \times x \times (T_{\text{sat}} - T_w)}{g \times h_{\text{fg}} \times \rho^2} \right)^{0.25}$$

(From HMT data book Page No.150)

$$\delta_x = \frac{4 \times 827.51 \times 10^{-6} \times 612 \times 10^{-3} \times .25 \times (41.53 - 20)100}{9.81 \times 2403.2 \times 10^3 \times 997^2}$$

$$\delta_x = 1.40 \times 10^{-4} \text{ m}$$

b. Local heat transfer coefficient  $h_x$  Assuming Laminar flow

$$h_x = \frac{k}{\delta x}$$

$$h_x = \frac{612 \times 10^{-3}}{1.46 \times 10^{-4}}$$

$$h_x = 4,191 \text{ W/m}^2\text{K}$$

c. Average heat transfer coefficient  $h$

(Assuming laminar flow)

$$h = 0.943 \left[ \frac{k^3 \times \rho^2 \times g \times h_{\text{fg}}}{\mu \times L \times T_{\text{sat}} - T_w} \right]^{0.25}$$

The factor 0.943 may be replaced by 1.13 for more accurate result as suggested by Mc adams

$$h = 0.943 \left[ \frac{k^3 \rho^2 g h_{\text{fg}}}{\mu \times L \times T_{\text{sat}} - T_w} \right]^{0.25}$$

Where  $L = 50 \text{ cm} = .5 \text{ m}$

$$h = 1.13 \left| \frac{(612 \times 10^{-3})^3 \times (997)^2 \times 9.81 \times 2403.2 \times 10^3}{827.51 \times 10^{-6} \times .5 \times 41.53 - 20} \right|^{0.25}$$

$$h = 5599.6 \text{ W/m}^2\text{k}$$

d. Heat transfer (Q)

We know

$$Q = hA(T_{\text{sat}} - T_w)$$

$$h \times A \times (T_{\text{sat}} - T_w) \\ = 5599.6 \times 0.25 \times (41.53 - 20)$$

$$Q = 30.139.8 \text{ W}$$

e. Total steam condensation rate (m)

We know Heat transfer

$$Q = m \times h_{\text{fg}}$$

$$m = \frac{Q}{h_{\text{fg}}}$$

$$m = \frac{30.139.8}{2403.2 \times 10^3}$$

$$m = 0.0125 \text{ kg/s}$$

f. If the plate is inclined at  $\theta$  with horizontal

$$h_{\text{inclined}} = h_{\text{vertical}} \times \sin \theta^{1/4}$$

$$h_{\text{inclined}} = h_{\text{vertical}} \times (\sin 30)^{1/4}$$

$$h_{\text{inclined}} = 5599.6 \times \left(\frac{1}{2}\right)^{1/4}$$

$$h_{\text{inclined}} = 4.708.6 \text{ W/m}^2\text{k}$$

Let us check the assumption of laminar film condensation

We know

$$\text{Reynolds Number } R_e = \frac{4m}{w\mu}$$

where

$$W = \text{width of the plate} = 50\text{cm} = .50\text{m}$$

$$R_e = \frac{4 \times .0125}{0.50 \times 827.51 \times 10^{-6}}$$

$$R_e = 120.8 < 1800$$

So our assumption laminar flow is correct.

9. Derive an expression for LMTD in Parallel flow and Counter flow heat exchangers.

changes in kinetic and potential energy, an energy balance on each fluid in a differential section of the heat exchanger can be expressed as

$$\delta\dot{Q} = -\dot{m}_h C_{ph} dT_h$$

and

$$\delta\dot{Q} = \dot{m}_c C_{pc} dT_c$$

That is, the rate of heat loss from the hot fluid at any section of a heat exchanger is equal to the rate of heat gain by the cold fluid in that section. The temperature change of the hot fluid is a *negative* quantity, and so a *negative sign* is added to make the heat transfer rate  $\dot{Q}$  a positive quantity.

Solving the equations above for  $dT_h$  and  $dT_c$  gives

$$dT_h = -\frac{\delta\dot{Q}}{\dot{m}_h C_{ph}}$$

and

$$dT_c = \frac{\delta\dot{Q}}{\dot{m}_c C_{pc}}$$

Taking their difference, we get

$$dT_h - dT_c = d(T_h - T_c) = -\delta\dot{Q} \left( \frac{1}{\dot{m}_h C_{ph}} + \frac{1}{\dot{m}_c C_{pc}} \right)$$

The rate of heat transfer in the differential section of the heat exchanger can also be expressed as

$$\delta\dot{Q} = U(T_h - T_c) dA_s$$

Substituting this equation into Eq. 13-20 and rearranging gives

$$\frac{d(T_h - T_c)}{T_h - T_c} = -U dA_s \left( \frac{1}{\dot{m}_h C_{ph}} + \frac{1}{\dot{m}_c C_{pc}} \right)$$

$$\delta\dot{Q} = U(T_h - T_c) dA_s$$

$$\frac{d(T_h - T_c)}{T_h - T_c} = -U dA_s \left( \frac{1}{\dot{m}_h C_{ph}} + \frac{1}{\dot{m}_c C_{pc}} \right)$$

$$\ln \frac{T_{h, out} - T_{c, out}}{T_{h, in} - T_{c, in}} = -UA_s \left( \frac{1}{\dot{m}_h C_{ph}} + \frac{1}{\dot{m}_c C_{pc}} \right)$$

$$\Delta T_{lm} = \frac{\Delta T_1 - \Delta T_2}{\ln (\Delta T_1 / \Delta T_2)}$$

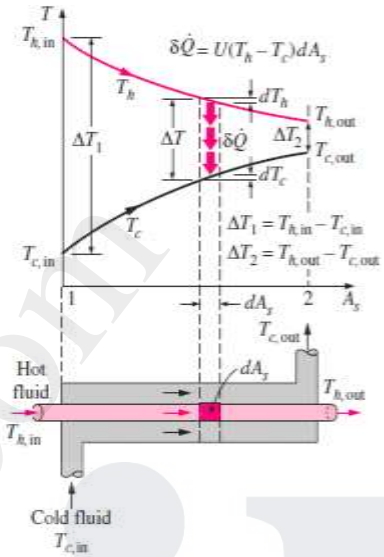

Variation of the fluid temperatures in a parallel-flow double-pipe heat exchanger.



10. Explain nucleate boiling and solve the following.

A wire of 1mm diameter and 150 mm length is submerged horizontally in water at 7 bar. The wire carries current of 131.5 ampere with an applied voltage of 2.15 Volt. If the surface of the wire is maintained at 180 °C, calculate the heat flux and boiling heat transfer coefficient. [MAY-JUN 14]

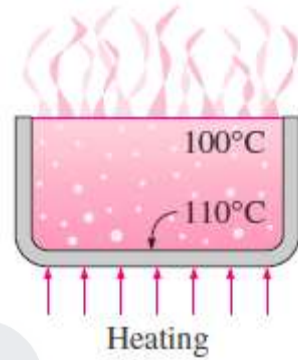

Nucleate boiling

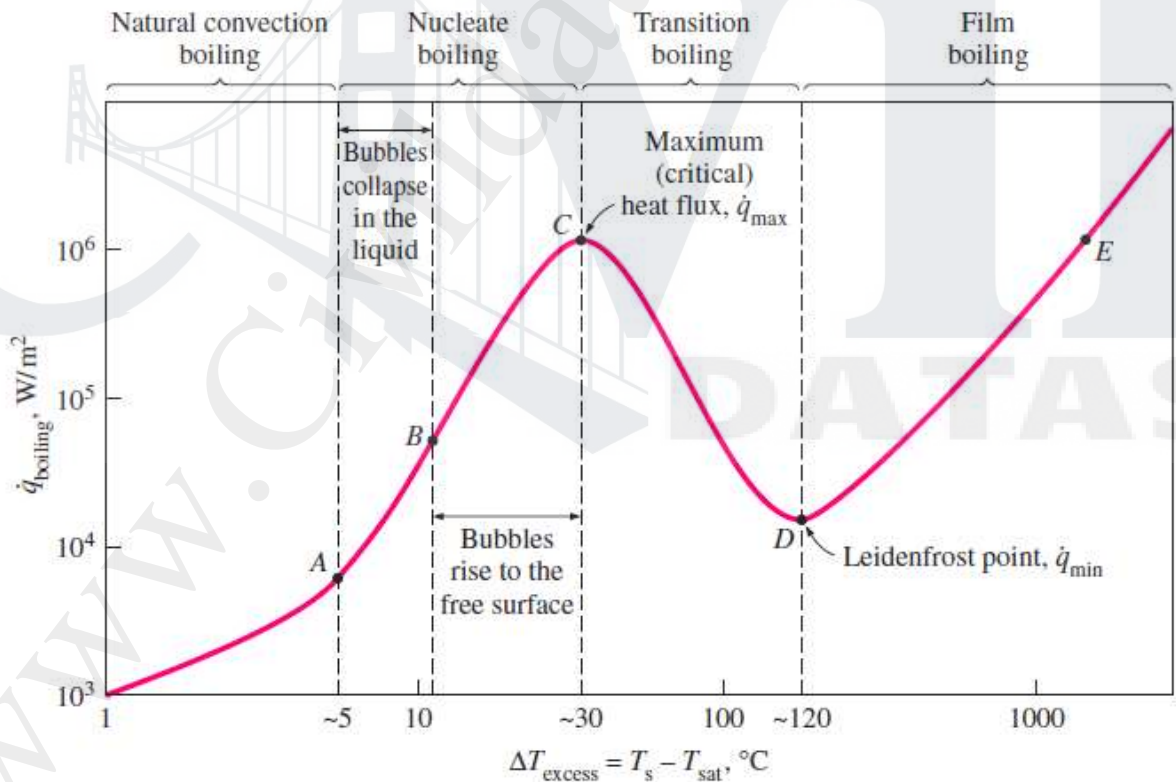

## Nucleate Boiling (between Points A and C)

The first bubbles start forming at point A of the boiling curve at various preferential sites on the heating surface. The bubbles form at an increasing rate at an increasing number of nucleation sites as we move along the boiling curve toward point C.

The nucleate boiling regime can be separated into two distinct regions. In region A–B, *isolated bubbles* are formed at various preferential nucleation sites on the heated surface. But these bubbles are dissipated in the liquid shortly after they separate from the surface. The space vacated by the rising bubbles is filled by the liquid in the vicinity of the heater surface, and the process is repeated. The stirring and agitation caused by the entrainment of the liquid to the heater surface is primarily responsible for the increased heat transfer coefficient and heat flux in this region of nucleate boiling.

In region B–C, the heater temperature is further increased, and bubbles form at such great rates at such a large number of nucleation sites that they form numerous *continuous columns of vapor* in the liquid. These bubbles move all the way up to the free surface, where they break up and release their vapor content. The large heat fluxes obtainable in this region are caused by the combined effect of liquid entrainment and evaporation.

11. Classify heat exchangers, draw temperature distribution in a condenser and evaporator and derive the Expression for effectiveness of parallel flow heat exchanger by NTU method. [MAY-JUN 14]

$$\dot{Q} = UA_x \Delta T_{lm}$$

$$\varepsilon = \frac{\dot{Q}}{\dot{Q}_{max}} = \frac{\text{Actual heat transfer rate}}{\text{Maximum possible heat transfer rate}}$$

$$\dot{Q} = C_c(T_{c, out} - T_{c, in}) = C_h(T_{h, in} - T_{h, out})$$

$$\Delta T_{max} = T_{h, in} - T_{c, in}$$

$$\dot{Q}_{max} = C_{min}(T_{h, in} - T_{c, in})$$

$$\dot{Q} = \varepsilon \dot{Q}_{\max} = \varepsilon C_{\min}(T_{h, \text{in}} - T_{c, \text{in}})$$

$$\ln \frac{T_{h, \text{out}} - T_{c, \text{out}}}{T_{h, \text{in}} - T_{c, \text{in}}} = -\frac{UA_s}{C_c} \left(1 + \frac{C_c}{C_h}\right) \quad (13-34)$$

$$T_{h, \text{out}} = T_{h, \text{in}} - \frac{C_c}{C_h}(T_{c, \text{out}} - T_{c, \text{in}}) \quad (13-35)$$

Substituting this relation into Eq. 13-34 after adding and subtracting  $T_{c, \text{in}}$  gives

$$\ln \frac{T_{h, \text{in}} - T_{c, \text{in}} + T_{c, \text{in}} - T_{c, \text{out}} - \frac{C_c}{C_h}(T_{c, \text{out}} - T_{c, \text{in}})}{T_{h, \text{in}} - T_{c, \text{in}}} = -\frac{UA_s}{C_c} \left(1 + \frac{C_c}{C_h}\right)$$

which simplifies to

$$\ln \left[ 1 - \left(1 + \frac{C_c}{C_h}\right) \frac{T_{c, \text{out}} - T_{c, \text{in}}}{T_{h, \text{in}} - T_{c, \text{in}}} \right] = -\frac{UA_s}{C_c} \left(1 + \frac{C_c}{C_h}\right) \quad (13-36)$$

We now manipulate the definition of effectiveness to obtain

$$\varepsilon = \frac{\dot{Q}}{\dot{Q}_{\max}} = \frac{C_c(T_{c, \text{out}} - T_{c, \text{in}})}{C_{\min}(T_{h, \text{in}} - T_{c, \text{in}})} \longrightarrow \frac{T_{c, \text{out}} - T_{c, \text{in}}}{T_{h, \text{in}} - T_{c, \text{in}}} = \varepsilon \frac{C_{\min}}{C_c}$$

Substituting this result into Eq. 13-36 and solving for  $\varepsilon$  gives the following relation for the effectiveness of a *parallel-flow* heat exchanger:

$$\varepsilon_{\text{parallel flow}} = \frac{1 - \exp \left[ -\frac{UA_s}{C_c} \left(1 + \frac{C_c}{C_h}\right) \right]}{\left(1 + \frac{C_c}{C_h}\right) \frac{C_{\min}}{C_c}} \quad (13-37)$$

Taking either  $C_c$  or  $C_h$  to be  $C_{\min}$  (both approaches give the same result), the relation above can be expressed more conveniently as

$$\varepsilon_{\text{parallel flow}} = \frac{1 - \exp \left[ -\frac{UA_s}{C_{\min}} \left(1 + \frac{C_{\min}}{C_{\max}}\right) \right]}{1 + \frac{C_{\min}}{C_{\max}}} \quad (13-38)$$

Temperature distribution of Condenser and Evaporator

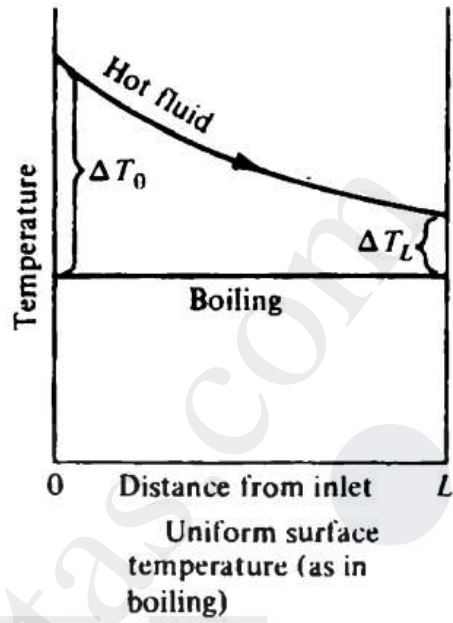
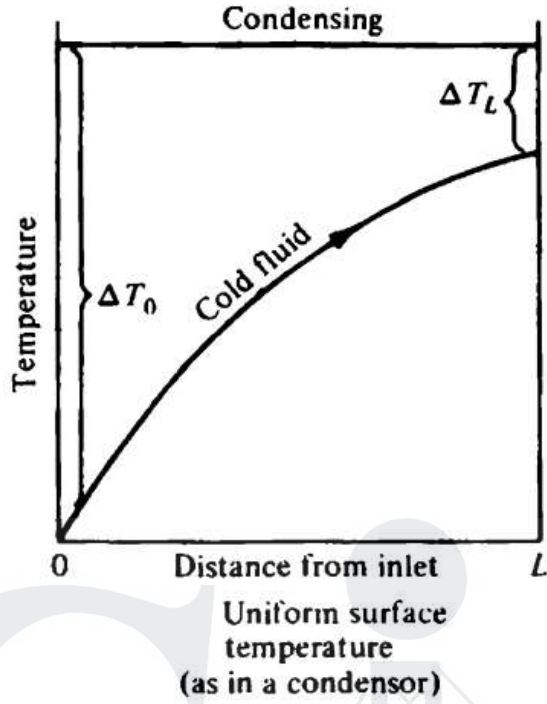

12. (i) Explain the various regions of flow boiling in detail.  
(ii) The outer surface of a vertical tube, which is 1m long and has an outer diameter of 80mm, is exposed to saturated steam at atmospheric pressure and is maintained at 50 °C by the flow of cool water through the tube. What is the rate of heat transfer to coolant and what is the rate at which steam is condensed at the surface? [NOV-DEC 13]

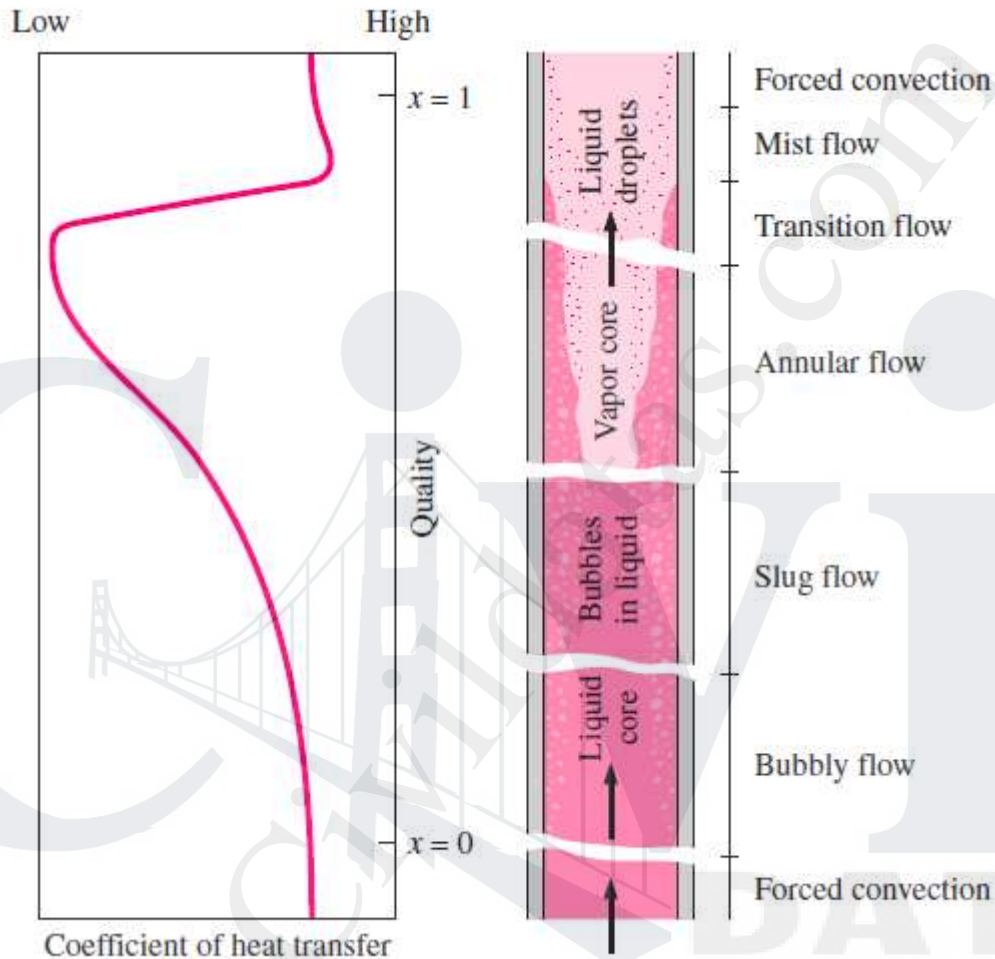

The different stages encountered in flow boiling in a heated tube are illustrated in Figure together with the variation of the heat transfer coefficient along the tube. Initially, the liquid is subcooled and heat transfer to the liquid is by *forced convection*. Then bubbles start forming on the inner surfaces of the tube, and the detached bubbles are drafted into the mainstream. This gives the fluid flow a bubbly appearance, and thus the name *bubbly flow regime*. As the fluid is heated further, the bubbles grow in size and eventually coalesce into slugs of vapor. Up to half of the volume in the tube in this *slug-flow regime* is occupied by vapor. After a while the core of the flow consists

of vapor only, and the liquid is confined only in the annular space between the vapor core and the tube walls. This is the *annular-flow regime*, and very high heat transfer coefficients are realized in this regime. As the heating continues, the annular liquid layer gets thinner and thinner, and eventually dry spots start to appear on the inner surfaces of the tube. The appearance of dry spots is accompanied by a sharp decrease in the heat transfer coefficient. This *transition regime* continues until the inner surface of the tube is completely dry. Any liquid at this moment is in the form of droplets suspended in the vapor core, which resembles a mist, and we have a *mist-flow regime* until all the liquid droplets are vaporized. At the end of the mist-flow regime we have saturated vapor, which becomes superheated with any further heat transfer.

Ref problem 3

## UNIT-4 RADIATION

### PART-A

#### 1. Define emissive power [E] and monochromatic emissive power. [ $E_{b\lambda}$ ]

The emissive power is defined as the total amount of radiation emitted by a body per unit time and unit area. It is expressed in  $W/m^2$ .

The energy emitted by the surface at a given length per unit time per unit area in all directions is known as monochromatic emissive power.

#### 2. What is meant by absorptivity, reflectivity and transmissivity?

- Absorptivity is defined as the ratio between radiation absorbed and incident radiation.
- Reflectivity is defined as the ratio of radiation reflected to the incident radiation.
- Transmissivity is defined as the ratio of radiation transmitted to the incident radiation.

#### 3. What is black body and gray body?

Black body is an ideal surface having the following properties.

A black body absorbs all incident radiation, regardless of wave length and direction. For a prescribed temperature and wave length, no surface can emit more energy than black body.

If a body absorbs a definite percentage of incident radiation irrespective of their wave length, the body is known as gray body. The emissive power of a gray body is always less than that of the black body.

#### 4. State Planck's distribution law. [NOV-DEC 13]

The relationship between the monochromatic emissive power of a black body and wave length of a radiation at a particular temperature is given by the following expression, by Planck.

$$E_{b\lambda} = \frac{C_1 \lambda^{-5}}{e \left( \frac{C_2}{\lambda T} \right) - 1}$$

Where  $E_{b\lambda}$  = Monochromatic emissive power  $W/m^2$

$$\begin{aligned}\lambda &= \text{Wave length} - m \\ c_1 &= 0.374 \times 10^{-15} \text{ W m}^2 \\ c_2 &= 14.4 \times 10^{-3} \text{ mK}\end{aligned}$$

### 5. State Wien's displacement law.

The Wien's law gives the relationship between temperature and wave length corresponding to the maximum spectral emissive power of the black body at that temperature.

$$\lambda_{\text{mas}} T = c_3$$

Where  $c_3 = 2.9 \times 10^{-3}$  [Radiation constant]

$$\Rightarrow \lambda_{\text{mas}} T = 2.9 \times 10^{-3} \text{ mK}$$

### 6. State Stefan – Boltzmann law.

The emissive power of a black body is proportional to the fourth power of absolute temperature.

$$E_b \propto T^4$$

$$E_b = \sigma T^4$$

Where  $E_b$  = Emissive power  $W/m^2$

$\sigma$  = Stefan Boltzmann constant =  $5.67 \times 10^{-8} \text{ W/m}^2 \text{ K}^4$

T = Temperature, K

### 7. Define Emissivity.

It is defined as the ability of the surface of a body to radiate heat. It is also defined as the ratio of emissive power of any body to the emissive power of a black body of equal temperature.

$$\text{Emissivity } \varepsilon = \frac{E}{E_b}$$

### 8. State Kirchhoff's law of radiation.

This law states that the ratio of total emissive power to the absorptivity is constant for all surfaces which are in thermal equilibrium with the surroundings. This can be written as

$$\frac{E_1}{\alpha_1} = \frac{E_2}{\alpha_2} = \frac{E_3}{\alpha_3}$$

It also states that the emissivity of the body is always equal to its absorptivity when the body remains in thermal equilibrium with its surroundings.

$\alpha_1 = E_1$ ;  $\alpha_2 = E_2$  and so on.

### 9. Define intensity of radiation ( $I_b$ ).

It is defined as the rate of energy leaving a space in a given direction per unit solid angle per unit area of the emitting surface normal to the mean direction in space.

$$I_n = \frac{E_b}{\pi}$$

### 10. State Lambert's cosine law.

It states that the total emissive power  $E_b$  from a radiating plane surface in any direction proportional to the cosine of the angle of emission

$$E_b \propto \cos \theta$$

### 11. What is the use of radiation shield? [NOV DEC 14]

Radiation shields constructed from low emissivity (high reflective) materials. It is used to reduce the net radiation transfer between two surfaces.

### 12. Define irradiation (G) and radiosity (J)

It is defined as the total radiation incident upon a surface per unit time per unit area. It is expressed in  $W/m^2$ .

It is used to indicate the total radiation leaving a surface per unit time per unit area. It is expressed in  $W/m^2$ .

**13. What is meant by shape factor?**

The shape factor is defined as the fraction of the radiative energy that is diffused from on surface element and strikes the other surface directly with no intervening reflections. It is represented by  $F_{ij}$ . Other names for radiation shape factor are view factor, angle factor and configuration factor.

**14. How radiation from gases differs from solids? [NOV DEC 13]**

A participating medium emits and absorbs radiation throughout its entire volume thus gaseous radiation is a volumetric phenomenon, solid radiation is a surface phenomena  
Gases emit and absorb radiation at a number of narrow wavelength bands. This is in contrast to solids, which emit and absorb radiation over the entire spectrum.

**15. Define irradiation and emissive power. [MAY JUN 14]**

The radiation flux incident on a surface from all directions is called irradiation (irradiation represents the rate at which radiation energy is incident on a surface per unit area of the surface) The radiation flux for emitted radiation is the emissive power (the rate at which radiation energy is emitted per unit area of the emitting surface)

**16. What does the view factor represent? When is the view factor from a surface to itself not zero?**

The view factor  $F_{i,j}$  represents the fraction of the radiation leaving surface  $i$  that strikes surface  $j$  directly. The view factor from a surface to itself is non-zero for concave surfaces.

**17. Write down any two shape factor algebra. [MAY-JUN 14]**

$$F_{22} = 0$$

summation rule:  $F_{21} + F_{22} = 1 \rightarrow F_{21} = 1$

reciprocity rule:  $A_1 F_{12} = A_2 F_{21} \rightarrow F_{12} = \frac{A_2}{A_1} F_{21} = \frac{D}{\pi D} (1) = \frac{2}{\pi} = 0.64$

$$F_{22} = 0$$

summation rule:  $F_{21} + F_{22} + F_{23} = 1 \rightarrow F_{21} = F_{23} = 0.5$  (symmetry)

summation rule:  $F_{22} + F_{2 \rightarrow (1+3)} = 1 \rightarrow F_{2 \rightarrow (1+3)} = 1$

reciprocity rule:  $A_2 F_{2 \rightarrow (1+3)} = A_{(1+3)} F_{(1+3) \rightarrow 2}$

$$\rightarrow F_{(1+3) \rightarrow 2} = F_{(1+3) \rightarrow \text{sur}} = \frac{A_2}{A_{(1+3)}} (1) = \frac{a}{2b}$$

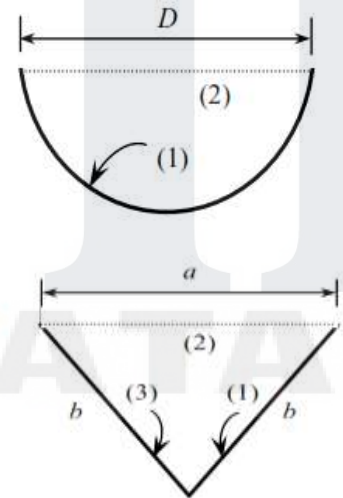

**19. What is a radiation shield? Why is it used?**

Radiation heat transfer between two surfaces can be reduced greatly by inserting a thin, high reflectivity (low emissivity) sheet of material between the two surfaces. Such highly reflective thin plates or shells are known as radiation shields. Multilayer radiation shields constructed of about 20 shields per cm. thickness separated by evacuated space are commonly used in cryogenic and space applications to minimize heat transfer. Radiation shields are also used in temperature measurements of fluids to reduce the error caused by the radiation effect.

**20. What is a blackbody? Does a blackbody actually exist?**

A blackbody is a perfect emitter and absorber of radiation. A blackbody does not actually exist. It is an idealized body that emits the maximum amount of radiation that can be emitted by a surface at a given temperature.



**21. What are the factors involved in radiation by a body? [NOV DEC 14]**

Radiation heat exchange between surfaces depends on the orientation of the surfaces relative to each other and this dependence on orientation is accounted by factor called view factor.

**PART B**

1. A Calculate the following for an industrial furnace in the form of a black body and emitting radiation at 2500 °C (i) Monochromatic emissive power at 1.2 μm length. ii) Wave length at which the emission is maximum. iii) Maximum emissive power iv) Total emissive power, and v) Total emissive power of the furnace if it is assumed as a real surface with emissivity equal to 0.9

[NOV DEC 14]

**Given:** Surface temperature  $T = 2773 \text{ K}$      $7 \mu\text{m}$      $\epsilon = 0.9$

**Solution: 1. Monochromatic Emissive Power :**

From Planck's distribution law, we know

$$E_{b\lambda} = \frac{C_1 \lambda^{-5}}{\left(\frac{C_2}{\lambda T}\right)_{-1}}$$

[From HMT data book, Page No.71]

Where

$$c_1 = 0.374 \times 10^{-15} \text{ W m}^2$$

$$c_2 = 14.4 \times 10^{-3} \text{ mK}$$

$$\lambda = 1 \times 10^{-6} \text{ m}$$

[Given]

**2. Maximum wave length ( $\lambda_{\text{max}}$ )**

From Wien's law, we know

$$\lambda_{\text{max}} T = 2.9 \times 10^{-3} \text{ mK}$$

**3. Maximum emissive power ( $E_{b\lambda}$ ) max:**

Maximum emissive power

$$(E_{b\lambda})_{\text{max}} = 1.307 \times 10^{-5} T^5$$

$$= 1.307 \times 10^{-5} \times (3000)^5$$

$$(E_{b\lambda})_{\text{max}} = 3.17 \times 10^{12} \text{ W/m}^2$$

**4. Total emissive power ( $E_b$ ):**

From Stefan – Boltzmann law, we know that

$$E_b = \sigma T^4$$

[From HMT data book Page No.71]

Where  $\sigma$  = Stefan – Boltzmann constant  
 $= 5.67 \times 10^{-8} \text{ W/m}^2\text{K}^4$

### 5. Total emissive power of a real surface:

$$(E_b)_{\text{real}} = \varepsilon \sigma T^4$$

Where  $\varepsilon$  = Emissivity = 0.85

2. Two parallel plates of size 1 m by 1m spaced 0.5 m apart are located in a very large room, the walls of which are maintained at temperature of 27 °C. One plate is maintained at a temperature of 900°C and other at 400 °C. Their emissivities are 0.2 and 0.5 respectively. If the plates exchange heat between themselves and surroundings, find the net heat transfer to each plate and to room. Consider only the plate surfaces facing each other. [NOV DEC 14]

Refer Problem 9 & 10

3. Two black square plates of size 2 by 2 m are placed parallel to each other at a distance of 0.5 m. One plate is maintained at a temperature of 1000°C and the other at 500°C. Find the heat exchange between the plates.

**Given:** Area  $A = 2 \times 2 = 4 \text{ m}^2$

$$T_1 = 1000^\circ\text{C} + 273$$

$$= 1273 \text{ K}$$

$$T_2 = 500^\circ\text{C} + 273$$

$$= 773 \text{ K}$$

Distance = 0.5 m

**To find :** Heat transfer (Q)

**Solution :** We know Heat transfer general equation is

$$\text{where } Q_{12} = \frac{\sigma [T_1^4 - T_2^4]}{\frac{1 - \epsilon_1}{A_1 \epsilon_1} + \frac{1}{A_1 F_{12}} + \frac{1 - \epsilon_2}{A_1 \epsilon_2}} \quad [\text{From equation No.(6)}]$$

For black body  $\epsilon_1 = \epsilon_2 = 1$

$$\Rightarrow Q_{12} = \sigma [T_1^4 - T_2^4] \times A_1 F_{12}$$

$$= 5.67 \times 10^{-8} [(1273)^4 - (773)^4] \times 4 \times F_{12}$$

$$\boxed{Q_{12} = 5.14 \times 10^5 F_{12}} \quad \dots\dots(1)$$

Where  $F_{12}$  – Shape factor for square plates

In order to find shape factor  $F_{12}$ , refer HMT data book, Page No.76.

$$\text{X axis} = \frac{\text{Smaller side}}{\text{Distance between planes}}$$

$$= \frac{2}{0.5}$$

$$\boxed{\text{X axis} = 4}$$

Curve  $\rightarrow 2$  [Since given is square plates]

X axis value is 4, curve is 2. So corresponding Y axis value is 0.62.

i.e.,  $\boxed{F_{12} = 0.62}$

$$(1) \Rightarrow Q_{12} = 5.14 \times 10^5 \times 0.62$$

$$\boxed{Q_{12} = 3.18 \times 10^5 \text{ W}}$$

4. A gas mixture contains 20%  $\text{CO}_2$  and 10%  $\text{H}_2\text{O}$  by volume. The total pressure is 2 atm. The temperature of the gas is  $927^\circ\text{C}$ . The mean beam length is 0.3 m. Calculate the emissivity of mixture

**Given :** Partial pressure of  $\text{CO}_2$ ,  $P_{\text{CO}_2} = 20\% = 0.20 \text{ atm}$

Partial pressure of  $\text{H}_2\text{O}$ ,  $P_{\text{H}_2\text{O}} = 10\% = 0.10 \text{ atm}$ .

Total pressure  $P = 2 \text{ atm}$

Temperature  $T = 927^\circ\text{C} + 273$   
 $= 1200 \text{ K}$

Mean beam length  $L_m = 0.3 \text{ m}$

**To find:** Emissivity of mixture ( $\epsilon_{\text{mix}}$ ).

**Solution : To find emissivity of CO<sub>2</sub>**

$$P_{\text{CO}_2} \times L_m = 0.2 \times 0.3$$

$$P_{\text{CO}_2} \times L_m = 0.06 \text{ m - atm}$$

From HMT data book, Page No.90, we can find emissivity of CO<sub>2</sub>.

From graph, Emissivity of CO<sub>2</sub> = 0.09

$$\varepsilon_{\text{CO}_2} = 0.09$$

**To find correction factor for CO<sub>2</sub>**

Total pressure, P = 2 atm

$$P_{\text{CO}_2} L_m = 0.06 \text{ m - atm.}$$

From HMT data book, Page No.91, we can find correction factor for CO<sub>2</sub>

From graph, correction factor for CO<sub>2</sub> is 1.25

$$C_{\text{CO}_2} = 1.25$$

$$\varepsilon_{\text{CO}_2} \times C_{\text{CO}_2} = 0.09 \times 1.25$$

$$\varepsilon_{\text{CO}_2} \times C_{\text{CO}_2} = 0.1125$$

**To find emissivity of H<sub>2</sub>O:**

$$P_{\text{H}_2\text{O}} \times L_m = 0.1 \times 0.3$$

$$P_{\text{H}_2\text{O}} L_m = 0.03 \text{ m - atm}$$

From HMT data book, Page No.92, we can find emissivity of H<sub>2</sub>O.

From graph Emissivity of H<sub>2</sub>O = 0.048

$$\varepsilon_{\text{H}_2\text{O}} = 0.048$$

**To find correction factor for H<sub>2</sub>O:**

$$\frac{P_{\text{H}_2\text{O}} + P}{2} = \frac{0.1 + 2}{2} = 1.05$$

$$\frac{P_{\text{H}_2\text{O}} + P}{2} = 1.05,$$

$$P_{\text{H}_2\text{O}} L_m = 0.03 \text{ m - atm}$$

From HMT data book, Page No.92 we can find emission of H<sub>2</sub>O

5. a) A furnace of 2 m × 1.5 m × 1.5 m size contains gases at 1500 K while the walls are at 500 K. The gas contains 18% of CO<sub>2</sub> and 12% of water vapour by volume. Determine the heat exchange from the gases to the walls. The total pressure is 2 atm. Assume black surface.

b) In a furnace of  $2 \times 1.5 \times 1$  m size, floor is at 1000 K and other surfaces are at 600 K. The surface emissivity for the floor is 0.8 and for the other surfaces it is 0.5. Determine the heat exchange by radiation from (i) floor to each of side walls and (ii) floor to roof.

Refer problem 4

6. Consider the  $5\text{m} \times 5\text{m} \times 5\text{m}$  cubical furnace, whose surfaces closely approximate black surfaces. The base, top, and side surfaces of the furnace are maintained at uniform temperatures of 800 K, 1500 K, and 500 K, respectively. Determine (a) the net rate of radiation heat transfer between the base and the side surfaces, (b) the net rate of radiation heat transfer between the base and the top surface, and (c) the net radiation heat transfer from the base surface.

$$\dot{Q}_{1 \rightarrow 3} = A_1 F_{1 \rightarrow 3} \sigma (T_1^4 - T_3^4)$$

$$F_{1 \rightarrow 1} + F_{1 \rightarrow 2} + F_{1 \rightarrow 3} = 1$$

$$\begin{aligned} \dot{Q}_{1 \rightarrow 3} &= (25 \text{ m}^2)(0.8)(5.67 \times 10^{-8} \text{ W/m}^2 \cdot \text{K}^4)[(800 \text{ K})^4 - (500 \text{ K})^4] \\ &= 394 \times 10^3 \text{ W} = 394 \text{ kW} \end{aligned}$$

$$\begin{aligned} \dot{Q}_{1 \rightarrow 2} &= A_1 F_{1 \rightarrow 2} \sigma (T_1^4 - T_2^4) \\ &= (25 \text{ m}^2)(0.2)(5.67 \times 10^{-8} \text{ W/m}^2 \cdot \text{K}^4)[(800 \text{ K})^4 - (1500 \text{ K})^4] \\ &= -1319 \times 10^3 \text{ W} = -1319 \text{ kW} \end{aligned}$$

$$\begin{aligned} \dot{Q}_1 &= \sum_{j=1}^3 \dot{Q}_{1 \rightarrow j} = \dot{Q}_{1 \rightarrow 1} + \dot{Q}_{1 \rightarrow 2} + \dot{Q}_{1 \rightarrow 3} \\ &= 0 + (-1319 \text{ kW}) + (394 \text{ kW}) \\ &= -925 \text{ kW} \end{aligned}$$

7. a) Two very large parallel plates are maintained at uniform temperatures  $T_1=800$  K and  $T_2=500$  K and have emissivities  $\epsilon_1=0.2$  and  $\epsilon_2=0.7$  respectively. Determine the net rate of radiation heat transfer between the two surfaces per unit surface area of the plates.

$$\dot{q}_{12} = \frac{\dot{Q}_{12}}{A} = \frac{\sigma(T_1^4 - T_2^4)}{\frac{1}{\epsilon_1} + \frac{1}{\epsilon_2} - 1} = \frac{(5.67 \times 10^{-8} \text{ W/m}^2 \cdot \text{K}^4)[(800 \text{ K})^4 - (500 \text{ K})^4]}{\frac{1}{0.2} + \frac{1}{0.7} - 1}$$

$$= 3625 \text{ W/m}^2$$

b) A thin aluminum sheet with an emissivity of 0.1 on both sides is placed between two very large parallel plates that are maintained at uniform temperatures  $T_1=800 \text{ K}$  and  $T_2=500 \text{ K}$  and have emissivities  $\epsilon_1= 0.2$  and  $\epsilon_2 =0.7$  respectively. Determine the net rate of radiation heat transfer between the two plates per unit surface area of the plates and compare the result to without the shield.

$$\dot{q}_{12, \text{ one shield}} = \frac{\dot{Q}_{12, \text{ one shield}}}{A} = \frac{\sigma(T_1^4 - T_2^4)}{\left(\frac{1}{\epsilon_1} + \frac{1}{\epsilon_2} - 1\right) + \left(\frac{1}{\epsilon_{3,1}} + \frac{1}{\epsilon_{3,2}} - 1\right)}$$

$$= \frac{(5.67 \times 10^{-8} \text{ W/m}^2 \cdot \text{K}^4)[(800 \text{ K})^4 - (500 \text{ K})^4]}{\left(\frac{1}{0.2} + \frac{1}{0.7} - 1\right) + \left(\frac{1}{0.1} + \frac{1}{0.1} - 1\right)}$$

$$= 806 \text{ W/m}^2$$

8. a) Consider a cylindrical furnace with  $r=H= 1\text{m}$ . The top (surface 1) and the base (surface 2) of the furnace has emissivities  $\epsilon_1= 0.8$  and  $\epsilon_2 =0.4$  respectively, and are maintained at uniform temperatures  $T_1=700 \text{ K}$  and  $T_2=500 \text{ K}$ . The side surface closely approximates a blackbody and is maintained at a temperature of  $T_3 = 400 \text{ K}$ . Determine the net rate of radiation heat transfer at each surface during steady operation and explain how these surfaces can be maintained at specified temperatures.

$$A_1 = A_2 = \pi r_o^2 = \pi(1 \text{ m})^2 = 3.14 \text{ m}^2$$

$$A_3 = 2\pi r_o H = 2\pi(1 \text{ m})(1 \text{ m}) = 6.28 \text{ m}^2$$

$$F_{11} + F_{12} + F_{13} = 1 \rightarrow F_{13} = 1 - F_{11} - F_{12} = 1 - 0 - 0.38 = 0.62$$

$$A_1 F_{13} = A_3 F_{31} \rightarrow F_{31} = F_{13}(A_1/A_3) = (0.62)(0.314/0.628) = 0.31$$

$$\dot{Q}_1 = A_1[F_{1 \rightarrow 2}(J_1 - J_2) + F_{1 \rightarrow 3}(J_1 - J_3)]$$

$$= (3.14 \text{ m}^2)[0.38(11,418 - 4562) + 0.62(11,418 - 1452)] \text{ W/m}^2$$

$$= 27.6 \times 10^3 \text{ W} = 27.6 \text{ kW}$$

$$\begin{aligned}\dot{Q}_2 &= A_2[F_{2 \rightarrow 1}(J_2 - J_1) + F_{2 \rightarrow 3}(J_2 - J_3)] \\ &= (3.12 \text{ m}^2)[0.38(4562 - 11,418) + 0.62(4562 - 1452)] \text{ W/m}^2 \\ &= -2.13 \times 10^3 \text{ W} = -2.13 \text{ kW}\end{aligned}$$

$$\begin{aligned}\dot{Q}_3 &= A_3[F_{3 \rightarrow 1}(J_3 - J_1) + F_{3 \rightarrow 2}(J_3 - J_2)] \\ &= (6.28 \text{ m}^2)[0.31(1452 - 11,418) + 0.31(1452 - 4562)] \text{ W/m}^2 \\ &= -25.5 \times 10^3 \text{ W} = -25.5 \text{ kW}\end{aligned}$$

$$\dot{Q}_1 + \dot{Q}_2 + \dot{Q}_3 = 27.6 + (-2.13) + (-25.5) \cong 0$$

b) A furnace is shaped like a long equilateral triangular duct. The width of each side is 1 m. The base surface has an emissivity of 0.7 and is maintained at a uniform temperature of 600 K. The heated left-side surface closely approximates a blackbody at 1000 K. The right-side surface is well insulated. Determine the rate at which heat must be supplied to the heated side externally per unit length of the duct in order to maintain these operating conditions.

$$\begin{aligned}\dot{Q}_1 &= \frac{(56,700 - 7348) \text{ W/m}^2}{\frac{1 - 0.7}{0.7 \times 1 \text{ m}^2} + \left[ (0.5 \times 1 \text{ m}^2) + \frac{1}{\frac{1}{(0.5 \times 1 \text{ m}^2)} + \frac{1}{(0.5 \times 1 \text{ m}^2)}} \right]^{-1}} \\ &= 28.0 \times 10^3 = 28.0 \text{ kW}\end{aligned}$$

9. (i) A truncated cone has top and bottom diameters of 10 and 20 cm and a height of 10 cm. Calculate the shape factor between the top surface and the side and also the shape factor between the side and itself.

$$F_{1 \rightarrow 1} + F_{1 \rightarrow 2} + F_{1 \rightarrow 3} = 1$$

$$A_i F_{i \rightarrow j} = A_j F_{j \rightarrow i}$$

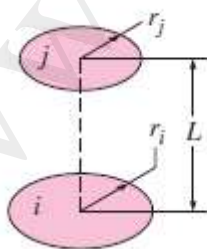

$$R_i = r_i/L \text{ and } R_j = r_j/L$$

$$S = 1 + \frac{1 + R_j^2}{R_i^2}$$

$$F_{i \rightarrow j} = \frac{1}{2} \left\{ S - \left[ S^2 - 4 \left( \frac{r_j}{r_i} \right)^2 \right]^{1/2} \right\}$$

(ii) Emissivities of two large parallel plates maintained at 800 °C and 300 °C and 0.3 and 0.5 respectively. Find the net radiant heat exchange per square meter for these plates [NOV DEC13]

$$\dot{q}_{12} = \frac{\dot{Q}_{12}}{A} = \frac{\sigma(T_1^4 - T_2^4)}{\frac{1}{\epsilon_1} + \frac{1}{\epsilon_2} - 1}$$

10. A 12 mm outside diameter pipe carries a cryogenic fluid at 90 K. Another pipe of 15 mm outside diameter and at 290 K surrounds it coaxially and the space between the pipes is completely evacuated (i) determine the radiant heat flow for 3.5 m length of pipe if the surface emissivity for both surface is 0.25 (ii) Calculate the percentage reduction in heat flow if a shield of 13.5 mm diameter and 0.06 surface emissivity is placed between pipes. [NOV-DEC 13]

$$\dot{q}_{12} = \frac{\dot{Q}_{12}}{A} = \frac{\sigma(T_1^4 - T_2^4)}{\frac{1}{\epsilon_1} + \frac{1}{\epsilon_2} - 1}$$

$$\dot{Q}_{12, \text{one shield}} = \frac{A\sigma(T_1^4 - T_2^4)}{\left(\frac{1}{\epsilon_1} + \frac{1}{\epsilon_2} - 1\right) + \left(\frac{1}{\epsilon_{3,1}} + \frac{1}{\epsilon_{3,2}} - 1\right)}$$

11. State laws of radiation and solve the following.

Assuming the sun to be black body emitting radiation with maximum intensity at  $\lambda = 0.5 \mu\text{m}$ , Calculate the surface temperature of the sun and the heat flux at its surface [MAY-JUN 14]

**Ans key**

The surface temp is found to be 5400 °C

Surface heat flux of sun 400 W/m<sup>2</sup>

12. Derive the relation for heat exchange between infinite parallel planes and solve.

Consider double wall as two infinite parallel planes. The emissivity of the wall is 0.3 and 0.8 respectively. The space between the walls is evacuated. Find the heat transfer/unit area when inner and outer surface temperatures are 300 K and 260 K. To Reduce the heat flow, a shield of polished aluminum with  $\epsilon = 0.05$  is inserted between the walls. Find the reduction in heat transfer.

[MAY-JUN 14]

$$\dot{q}_{12} = \frac{\dot{Q}_{12}}{A} = \frac{\sigma(T_1^4 - T_2^4)}{\frac{1}{\epsilon_1} + \frac{1}{\epsilon_2} - 1}$$



$$\dot{Q}_{12, \text{one shield}} = \frac{A\sigma(T_1^4 - T_2^4)}{\left(\frac{1}{\epsilon_1} + \frac{1}{\epsilon_2} - 1\right) + \left(\frac{1}{\epsilon_{3,1}} + \frac{1}{\epsilon_{3,2}} - 1\right)}$$

## UNIT-5 MASS TRANSFER

### PART-A

#### 1. What is mass transfer?

The process of transfer of mass as a result of the species concentration difference in a mixture is known as mass transfer.

#### 2. Give the examples of mass transfer.

Some examples of mass transfer.

1. Humidification of air in cooling tower
2. Evaporation of petrol in the carburetor of an IC engine.
3. The transfer of water vapour into dry air.

#### 3. List Out the various modes of mass transfer? [NOV DEC 14]

There are basically two modes of mass transfer,

- (i) Diffusion mass transfer
- (ii) Convective mass transfer

#### 4. What is molecular diffusion?

The transport of water on a microscopic level as a result of diffusion from a region of higher concentration to a region of lower concentration in a mixture of liquids or gases is known as molecular diffusion.

#### 5. What is Eddy diffusion?

When one of the diffusion fluids is in turbulent motion, eddy diffusion takes place.

#### 6. What is convective mass transfer?

Convective mass transfer is a process of mass transfer that will occur between surface and a fluid medium when they are at different concentration.

#### 7. State Fick's law of diffusion. [MAY JUN 14] [NOV DEC 13] [NOV DEC 14]

The diffusion rate is given by the Fick's law, which states that molar flux of an element per unit area is directly proportional to concentration gradient.

$$\frac{m_a}{A} = -D_{ab} \frac{dC_a}{dx}$$

where,

$$\frac{m_a}{A} \text{ - Molar flux, } \frac{\text{kg -mole}}{\text{s-m}^2}$$

$D_{ab}$  Diffusion coefficient of species a and b,  $\text{m}^2 / \text{s}$

$$\frac{dC_a}{dx} \text{ - concentration gradient, } \text{kg/m}^3$$

#### 8. What is free convective mass transfer?

If the fluid motion is produced due to change in density resulting from concentration gradients, the mode of mass transfer is said to be free or natural convective mass transfer.

Example : Evaporation of alcohol.

#### 9. Define forced convective mass transfer.

If the fluid motion is artificially created by means of an external force like a blower or fan, that type of mass transfer is known as convective mass transfer.

Example: The evaluation of water from an ocean when air blows over it.

**10. Define Schmidt Number.**

It is defined as the ratio of the molecular diffusivity of momentum to the molecular diffusivity of mass.

$$Sc = \frac{\text{Molecular diffusivity of momentum}}{\text{Molecular diffusivity of mass}}$$

**11. Define Sherwood Number.**

It is defined as the ratio of concentration gradients at the boundary.

$$Sc = \frac{h_m x}{D_{ab}}$$

$h_m$  = Mass transfer coefficient, m/s

$D_{ab}$  = Diffusion coefficient, m<sup>2</sup>/s

$x$  = Length, m

**12. Define Schmidt and Lewis number. What is the physical significance of each? [NOV DEC 13]**

The dimensionless **Schmidt number** is defined as the ratio of momentum diffusivity to mass diffusivity  $Sc = \nu/D_{AB}$ , and it represents the relative magnitudes of momentum and mass diffusion at molecular level in the velocity and concentration boundary layers, respectively. The Schmidt number diffusivity corresponds to the *Prandtl number* in heat transfer. A Schmidt number of *unity* indicates that momentum and mass transfer by diffusion are comparable, and velocity and concentration boundary layers almost coincide with each other.

The dimensionless **Lewis number** is defined as the ratio of thermal diffusivity to mass diffusivity  $Le = \alpha / D_{AB}$  and it represents the relative magnitudes of heat and mass diffusion at molecular level in the thermal and concentration boundary layers, respectively. A Lewis number of unity indicates that heat and mass diffuse at the same rate, and the thermal and concentration boundary layers coincide.

**13. Write down the analogous terms in heat and mass transfer. [MAY-JUN 14]**

Schmidt number is analogous to Prandtl number.

Sherwood number is analogous to Nusselt number.

**14. Does a mass transfer process have to involve heat transfer? Describe a process that involves both heat and mass transfer.**

In steady operation, the mass transfer process does not have to involve heat transfer. However, a mass transfer process that involves phase change (evaporation, sublimation, condensation, melting etc.) must involve heat transfer. For example, the evaporation of water from a lake into air (mass transfer) requires the transfer of latent heat of water at a specified temperature to the liquid water at the surface (heat transfer).

**15. Express mass convection in an analogous manner to heat transfer on a mass basis, and identify all the quantities in the expression and state their units.**

Mass convection is expressed on a mass basis in an analogous manner to heat transfer as

$$\dot{m}_{conv} = h_{mass} A_s (\rho_{A,s} - \rho_{A,\infty})$$

where  $h_{mass}$  is the average mass transfer coefficient in m/s,  $A_s$  is the surface area in m<sup>2</sup> and  $\rho_{A,s}$  and  $\rho_{A,\infty}$  are the densities of species A at the surface (on the fluid side) and the free stream respectively.

**16. What is permeability? How is the permeability of a gas in a solid related to the solubility of the gas in that solid?**

The permeability is a measure of the ability of a gas to penetrate a solid. The permeability of a gas in a solid, P, is related to the solubility of the gas by  $P = S D_{AB}$  where  $D_{AB}$  is the diffusivity of the gas in the solid.

**17. How does the mass diffusivity of a gas mixture change with (a) temperature and (b) Pressure?**

The mass diffusivity of a gas mixture ( $a$ ) increases with increasing temperature and ( $a$ ) decreases with increasing pressure.

**18. How does mass transfer differ from bulk fluid flow? Can mass transfer occur in a homogeneous medium?**

Bulk fluid flow refers to the transportation of a fluid on a macroscopic level from one location to another in a flow section by a mover such as a fan or a pump. Mass flow requires the presence of two regions at different chemical compositions, and it refers to the movement of a chemical species from a high concentration region towards a lower concentration one relative to the other chemical species present in the medium.

Mass transfer cannot occur in a homogeneous medium.

**19. How is the concentration of a commodity defined? How is the concentration gradient defined? How is the diffusion rate of a commodity related to the concentration gradient?**

The concentration of a commodity is defined as the amount of that commodity per unit volume. The concentration gradient  $dC/dx$  is defined as the change in the concentration  $C$  of a commodity per unit length in the direction of flow  $x$ . The diffusion rate of the commodity is expressed as

$$\dot{Q} = -k_{diff} A \frac{dC}{dx}$$

where  $A$  is the area normal to the direction of flow and  $k$  is the diffusion coefficient of the medium which is a measure of how fast a commodity diffuses in the medium.

**20. Give examples for (a) liquid-to-gas, (b) solid-to liquid, (c) solid-to-gas, and (d) gas-to liquid mass transfer.**

Examples of different kinds of diffusion processes:

- (a) Liquid-to-gas: A barrel of gasoline left in an open area will eventually evaporate and diffuse into air.
- (b) Solid-to-liquid: A spoon of sugar in a cup of tea will eventually dissolve and move up.
- (c) Solid-to gas: camphor left in a closet will sublime and diffuse into the air.
- (d) Gas-to-liquid: Air dissolves in water.

**21. Both Fourier's law of heat conduction and Fick's law of mass diffusion can be expressed as  $Q = kA(dT/dx)$ . What,  $k$ ,  $A$ , and  $T$  represent in (a) heat conduction and (b) mass diffusion?**

In the relation  $Q = kA(dT/dx)$ , the quantities  $Q$ ,  $k$ ,  $A$ , and  $T$  represent the following in heat conduction and mass diffusion

$Q$  = Rate of heat transfer in heat conduction, and rate of mass transfer in mass diffusion.

$k$  = Thermal conductivity in heat conduction, and mass diffusivity in mass diffusion.

$A$  = Area normal to the direction of flow in both heat and mass transfer.

$T$  = Temperature in heat conduction, and concentration in mass diffusion.

**22. What do (a) homogeneous reactions and (b) heterogeneous reactions represent in mass transfer? To what do they correspond in heat transfer?**

(a) *Homogenous reactions* in mass transfer represent the generation of a species within the medium. Such reactions are analogous to internal heat generation in heat transfer.

(b) *Heterogeneous reactions* in mass transfer represent the generation of a species at the surface as a result of chemical reactions occurring at the surface. Such reactions are analogous to specified surface heat flux in heat transfer.

## PART B

1. Hydrogen gases at 3 bar and 1 bar are separated by a plastic membrane having thickness 0.25 mm. the binary diffusion coefficient of hydrogen in the plastic is  $9.1 \times 10^{-3} \text{ m}^2/\text{s}$ . The solubility of hydrogen in the membrane is  $2.1 \times 10^{-3} \frac{\text{kg-mole}}{\text{m}^3 \text{ bar}}$

An uniform temperature condition of 20° is assumed.  
 Calculate the following

- Molar concentration of hydrogen on both sides
- Molar flux of hydrogen
- Mass flux of hydrogen

**Given Data:**

Inside pressure  $P_1 = 3$  bar

Outside pressure  $P_2 = 1$  bar

Thickness,  $L = 0.25$  mm =  $0.25 \times 10^{-3}$  m

Diffusion coefficient  $D_{ab} = 9.1 \times 10^{-8}$  m<sup>2</sup>/s

Solubility of hydrogen =  $2.1 \times 10^{-3} \frac{\text{kg-mole}}{\text{m}^3 \text{-bar}}$

Temperature  $T = 20^\circ\text{C}$

**To find**

Molar concentration on both sides  $C_{a1}$  and  $C_{a2}$

Molar flux

Mass flux

**Solution :**

1. Molar concentration on inner side,

$C_{a1} = \text{Solubility} \times \text{inner pressure}$

$$C_{a2} = 2.1 \times 10^{-3} \times 3$$

$$C_{a1} = 6.3 \times 10^{-3} \frac{\text{kg - mole}}{\text{m}^3}$$

Molar concentration on outer side

$C_{a1} = \text{solubility} \times \text{Outer pressure}$

$$C_{a2} = 2.1 \times 10^{-3} \times 1$$

$$C_{a2} = 2.1 \times 10^{-3} \frac{\text{kg - mole}}{\text{m}^3}$$

2. We know  $\frac{m_o}{A} = \frac{D_{ab}}{L} [C_{a1} - C_{a2}]$

$$\text{Molar flux, } = \frac{9.1}{.25 \times 10^{-3}} \frac{(6.3 \times 10^{-3} - 2.1 \times 10^{-3})}{1.2 - 0}$$

$$\frac{m_a}{A} = 1.52 \times 10^{-6} \frac{\text{kg-mole}}{\text{s-m}^2}$$

3. Mass flux = Molar flux  $\times$  Molecular weight

$$= 1.52 \times 10^{-6} \frac{\text{kg - mole}}{\text{s - m}^2} \times 2 \text{ mole}$$

[  $\because$  Molecular weight of  $\text{H}_2$  is 2 ]

$$\text{Mass flux} = 3.04 \times 10^{-6} \frac{\text{kg}}{\text{s - m}^2}$$

2. a) Oxygen at 25°C and pressure of 2 bar is flowing through a rubber pipe of inside diameter 25 mm and wall thickness 2.5 mm. The diffusivity of O<sub>2</sub> through rubber is  $0.21 \times 10^{-9} \text{ m}^2/\text{s}$  and the solubility of O<sub>2</sub> in rubber is  $3.12 \times 10^{-3} \frac{\text{kg-mole}}{\text{m}^3\text{-bar}}$ . Find the loss of O<sub>2</sub> by diffusion per metre length of pipe.
- b) An open pan 210 mm in diameter and 75 mm deep contains water at 25°C and is exposed to dry atmospheric air. Calculate the diffusion coefficient of water in air. Take the rate of diffusion of water vapour is  $8.52 \times 10^{-4} \text{ kg/h}$ .

**Given data:**

Temperature,  $T = 25^\circ\text{C}$

Inside pressure  $P_1 = 2 \text{ bar}$

Inner diameter  $d_1 = 25 \text{ mm}$

Inner radius  $r_1 = 12.5 \text{ mm} = 0.0125 \text{ m}$

Outer radius  $r_2 = \text{inner radius} + \text{Thickness}$

$$= 0.0125 + 0.0025$$

$$r_2 = 0.015 \text{ m}$$

Diffusion coefficient,  $D_{ab} = 0.21 \times 10^{-9} \text{ m}^2/\text{s}$

Solubility,  $= 3.12 \times 10^{-3} \frac{\text{kg-mole}}{\text{m}^3}$

Molar concentration on outer side,

$C_{a2} = \text{Solubility} \times \text{Outer pressure}$

$$C_{a2} = 3.12 \times 10^{-3} \times 0$$

$$C_{a2} = 0$$

[Assuming the partial pressure of O<sub>2</sub> on the outer surface of the tube is zero]

We know,

$$\frac{m_a}{A} = \frac{D_{ab} [C_{a1} - C_{a2}]}{L}$$

$$\text{For cylinders, } L = r_2 - r_1; A = \frac{2\pi L (r_2 - r_1)}{\ln \left[ \frac{r_2}{r_1} \right]}$$

$$\begin{aligned} \text{Molar flux, (1)} &\Rightarrow \frac{m_a}{2\pi L(r_2 - r_1)} = \frac{D_{ab} [C_{a1} - C_{a2}]}{(r_2 - r_1)} \\ &\Rightarrow m_a = \frac{2\pi L D_{ab} [C_{a1} - C_{a2}]}{\ln \frac{r_2}{r_1}} \quad [ \because \text{Length} = 1\text{m} ] \\ m_a &= 4.51 \times 10^{-11} \frac{\text{kg-mole}}{\text{s}} \end{aligned}$$

3. a) An open pan of 150 mm diameter and 75 mm deep contains water at 25°C and is exposed to atmospheric air at 25°C and 50% R.H. Calculate the evaporation rate of water in grams per hour. b) Air at 10°C with a velocity of 3 m/s flows over a flat plate. The plate is 0.3 m long. Calculate the mass transfer coefficient.

**Given :**

Diameter,  $d = 150\text{mm} = .150\text{m}$   
 Deep  $(x_2 - x_1) = 75 \text{ mm} = .075\text{m}$   
 Temperature,  $T = 25 + 273 = 298 \text{ K}$   
 Relative humidity = 50%

**To find**

Evaporation rate of water in grams per hour

**Solution:**

Diffusion coefficient ( $D_{ab}$ ) [water + air] at 25°C

$$= 93 \times 10^{-3} \text{ m}^2 / \text{h}$$

$$\Rightarrow D_{ab} = \frac{93 \times 10^{-3}}{3600} \text{ m}^2 / \text{s}$$

$$\boxed{D_{ab} = 2.58 \times 10^{-5} \text{ m}^2 / \text{s}}$$

Atmospheric air 50% RH (2)

We know that, for isothermal evaporation,

Molar flux,

$$\frac{m_a}{A} = \frac{D_{ab}}{GT} \frac{P}{(x_2 - x_1)} \ln \left[ \frac{P - P_{w2}}{P - P_{w1}} \right] \dots\dots(1)$$

where,

$$A - \text{Area} = \frac{\pi}{4} d^2 = \frac{\pi}{4} \times (.150)^2$$

$$[\text{Area} = 0.0176 \text{ m}^2]$$

$$G - \text{Universal gas constant} = 8314 \frac{\text{J}}{\text{kg-mole-K}}$$

$$P - \text{Total pressure} = 1 \text{ bar} = 1 \times 10^5 \text{ N/m}^2$$

$P_{w1}$  - Partial pressure at the bottom of the test tube corresponding to saturation temperature 25°C

At 25°C

$$P_{w1} = 0.03166 \text{ bar}$$

$$P_{w1} = 0.03166 \times 10^5 \text{ N/m}^2$$

$P_{w2}$  = Partial pressure at the top of the test pan corresponding to 25°C and 50% relative humidity.

At 25°C

$$P_{w2} = 0.03166 \text{ bar} = 0.03166 \times 10^5 \times 0.50$$

$$P_{w2} = 0.03166 \times 10^5 \times 0.50$$

$$P_{w2} = 1583 \text{ N/m}^2$$

$$(1) \Rightarrow \frac{a}{0.0176}$$

$$= \frac{2.58 \times 10^{-5}}{8314 \times 298} \times \frac{1 \times 10^5}{0.075} \times \ln \left[ \frac{1 \times 10^5 - 1583}{1 \times 10^5 - 0.03166 \times 10^5} \right]$$

$$\text{Molar rate of water vapour, } m_a = 3.96 \times 10^{-9} \frac{\text{kg-mole}}{\text{s}}$$

$$\begin{aligned} \text{Mass rate of water vapour} &= \text{Molar rate of water vapour} \times \text{Molecular weight of steam} \\ &= 3.96 \times 10^{-9} \times 18 \end{aligned}$$

$$\text{Mass rate of water vapour} = 7.13 \times 10^{-8} \text{ kg/s.}$$

$$= 7.13 \times 10^{-8} \times \frac{1000\text{g}}{3600\text{h}}$$

$$\boxed{\text{Mass rate of water vapour} = 0.256 \text{ g/h}}$$

4. Explain Reynold's number, Sherwood number, Schmidt number and solve the following.  
A vessel contains a binary mixture of oxygen and nitrogen with partial pressures in the ratio 0.21 and 0.79 at 15 C. The total pressure of the following mixture is 1.1 bar. Calculate the following.  
i) Molar concentrations ii) Mass densities iii) Mass fractions iv) Molar fractions of each species.  
[MAY-JUN 14]

Sherwood number is defined as the ratio of concentration gradients at the boundary.

$$Sc = \frac{h_m x}{D_{ab}}$$

$h_m$  – Mass transfer coefficient, m/s

$D_{ab}$  – Diffusion coefficient,  $\text{m}^2/\text{s}$

$x$  – Length, m

Schmidt number is defined as the ratio of the molecular diffusivity of momentum to the molecular diffusivity of mass.

$$Sc = \frac{\text{Molecular diffusivity of momentum}}{\text{Molecular diffusivity of mass}}$$

Molar concentration

$$M = \sum y_i M_i$$

Mass fraction

$$w_{N_2} = y_{N_2} \frac{M_{N_2}}{M}$$



$$w_{O_2} = y_{O_2} \frac{M_{O_2}}{M}$$

5. Air is contained in a tyre tube of surface area  $0.5 \text{ m}^2$  and wall thickness  $10 \text{ mm}$ . The pressure of air drops from  $2.2 \text{ bar}$  to  $2.18 \text{ bar}$  in a period of  $6 \text{ days}$ . The solubility of air in the rubber is  $0.72 \text{ m}^3$  of air per  $\text{m}^3$  of rubber at  $1 \text{ bar}$ . Determine the diffusivity of air in rubber at the operating temperature of  $300 \text{ K}$  if the volume of air in the tube is  $0.028 \text{ m}^3$ .

$$\dot{N}_{\text{diff, A, wall}} = CD_{AB}A \frac{y_{A,1} - y_{A,2}}{L} = D_{AB}A \frac{C_{A,1} - C_{A,2}}{L} = \frac{y_{A,1} - y_{A,2}}{\bar{R}_{\text{diff, wall}}}$$

6. A 3-cm-diameter Stefan tube is used to measure the binary diffusion coefficient of water vapor in air at  $20^\circ\text{C}$  at an elevation of  $1600 \text{ m}$  where the atmospheric pressure is  $83.5 \text{ kPa}$ . The tube is partially filled with water, and the distance from the water surface to the open end of the tube is  $40 \text{ cm}$ . Dry air is blown over the open end of the tube so that water vapor rising to the top is removed immediately and the concentration of vapor at the top of the tube is zero. In  $15 \text{ days}$  of continuous operation at constant pressure and temperature, the amount of water that has evaporated is measured to be  $1.23 \text{ g}$ . Determine the diffusion coefficient of water vapor in air at  $20^\circ\text{C}$  and  $83.5 \text{ kPa}$ .

$$y_{\text{vapor}, 0} = y_{A, 0} = \frac{P_{\text{vapor}, 0}}{P} = \frac{2.34 \text{ kPa}}{83.5 \text{ kPa}} = 0.0280$$

$$C = \frac{P}{R_u T} = \frac{83.5 \text{ kPa}}{(8.314 \text{ kPa} \cdot \text{m}^3/\text{kmol} \cdot \text{K})(293 \text{ K})} = 0.0343 \text{ kmol/m}^3$$

$$A = \pi D^2/4 = \pi(0.03 \text{ m})^2/4 = 7.069 \times 10^{-4} \text{ m}^2$$

$$\dot{N}_A = \dot{N}_{\text{vapor}} = \frac{\dot{m}_{\text{vapor}}}{M_{\text{vapor}}} = \frac{1.23 \times 10^{-3} \text{ kg}}{(15 \times 24 \times 3600 \text{ s})(18 \text{ kg/kmol})} = 5.27 \times 10^{-11} \text{ kmol/s}$$

$$D_{AB} = 3.06 \times 10^{-5} \text{ m}^2/\text{s}$$

7. a) Dry air at atmospheric pressure blows across a thermometer that is enclosed in a dampened cover. This is the classical wet-bulb thermometer. The thermometer reads a temperature of  $18^\circ\text{C}$ . What is the temperature of the dry air? (Without using psychrometric chart)

b) If the airstream in above problem is at 32°C, while the wet-bulb temperature remains at 18 °C, calculate the relative humidity of the airstream. (Without using psychrometric chart)

$$\left( \begin{array}{l} \text{Rate of heat} \\ \text{transfer from} \\ \text{air to wet} \\ \text{cover} \end{array} \right) = \left( \begin{array}{l} \text{heat removed} \\ \text{by evaporation} \\ \text{of water from} \\ \text{cover} \end{array} \right)$$

$$Ah_m(T_\infty - T_w) = Ak_m(c_w - c_\infty)h_{fg}$$

$$\frac{h_m}{k_m}(T_\infty - T_w) = (c_w - c_\infty)h_{fg}$$

$$\rho c_p \left( \frac{\alpha}{D} \right)^{2/3} (T_\infty - T_w) = (c_w - c_\infty)h_{fg}$$

$$c_w = \frac{P_w M_w}{R T_w}$$

8. During a certain experiment involving the flow of dry air at 25°C and 1 atm at a free stream velocity of 2 m/s over a body covered with a layer of naphthalene, it is observed that 12 g of naphthalene has sublimated in 15 min. The surface area of the body is 0.3 m<sup>2</sup>. Both the body and the air were kept at 25°C during the study. The vapor pressure of naphthalene at 25°C is 11 Pa and the mass diffusivity of naphthalene in air at 25°C is  $D_{AB} = 0.61 \times 10^{-5}$  m<sup>2</sup>/s. Determine the heat transfer coefficient under the same flow conditions over the same geometry.

$$w_{A,s} = \frac{P_{A,s}}{P} \left( \frac{M_A}{M_{\text{air}}} \right) = \frac{11 \text{ Pa}}{101,325 \text{ Pa}} \left( \frac{128.2 \text{ kg/kmol}}{29 \text{ kg/kmol}} \right) = 4.8 \times 10^{-4}$$

$$\dot{m}_{\text{evap}} = \frac{m}{\Delta t} = \frac{0.012 \text{ kg}}{(15 \times 60 \text{ s})} = 1.33 \times 10^{-5} \text{ kg/s}$$

$$h_{\text{mass}} = \frac{\dot{m}}{\rho A_s (w_{A,s} - w_{A,\infty})} = \frac{1.33 \times 10^{-5} \text{ kg/s}}{(1.184 \text{ kg/m}^3)(0.3 \text{ m}^2)(4.8 \times 10^{-4} - 0)} = 0.0780 \text{ m/s}$$

$$\begin{aligned}
 h_{\text{heat}} &= \rho C_p h_{\text{mass}} \left( \frac{\alpha}{D_{AB}} \right)^{2/3} \\
 &= (1.184 \text{ kg/m}^3)(1007 \text{ J/kg} \cdot ^\circ\text{C})(0.0776 \text{ m/s}) \left( \frac{2.141 \times 10^{-5} \text{ m}^2/\text{s}}{0.61 \times 10^{-5} \text{ m}^2/\text{s}} \right)^{2/3} \\
 &= \mathbf{215 \text{ W/m}^2 \cdot ^\circ\text{C}}
 \end{aligned}$$

9. Explain different modes of mass transfer and derive the general mass diffusion equation in stationary media. [MAY-JUN 14]

$$\frac{\partial^2 C_a}{\partial x^2} + \frac{\partial^2 C_a}{\partial y^2} + \frac{\partial^2 C_a}{\partial z^2} = \frac{1}{D} \frac{\partial C_a}{\partial \tau}$$

$$\frac{N_a}{A} = -D_{ab} \frac{dC_a}{dx}$$

$$\frac{N_b}{A} = -D_{ba} \frac{dC_b}{dx} = -D_{ba} \frac{d(1 - C_a)}{dx} = D_{ba} \frac{dC_a}{dx}$$

$$\frac{N_a}{A} = -\frac{N_b}{A} \text{ and so } D_{ab} = D_{ba}$$

$$\frac{N_b}{A} = -\frac{N_a}{A}, \text{ and } (C_{a1} - C_{a2}) = (C_{b2} - C_{b1})$$

$$\frac{N_a}{A} = \frac{D}{RT} \frac{P_{a1} - P_{a2}}{(x_2 - x_1)}$$

$$N_a = (C_{a1} - C_{a2})/R$$

$$R_p = \frac{L}{D_{ab}A}$$

$$R_{cyl} = \frac{\ln(r_2 / r_1)}{2\pi D_{ab} L}$$

$$R_{sp} = \frac{1}{4\pi D_{ab}} \left[ \frac{1}{r_1} - \frac{1}{r_2} \right]$$

10. Air at 35 °C and 1 atmosphere flows at a velocity of 60 m/s (i) a flat plate 0.5 m long (ii) a sphere 5 cm in diameter. Calculate the mass transfer coefficient of water in air. Neglect the concentration of vapor in air. [NOV-DEC 13]

Refer problem No 3

11. a) Discuss about steady state equimolar counter diffusion.  
b) Hydrogen gas is maintained at pressure of 2.4 bar and 1 bar on opposite sides of a plastic membrane 0.3 mm thick. The binary diffusion coefficient of hydrogen in the plastic is  $8.6 \times 10^{-8} \text{ m}^2/\text{s}$  and solubility of hydrogen in the membrane is  $0.00145 \text{ kg mole} / \text{m}^3 \cdot \text{Bar}$ . Calculate under uniform temperature conditions of 24 °C the following (1) Molar concentration of hydrogen at the opposite faces of the membrane, and (2) Molar and mass diffusion flux of hydrogen through the membrane.
12. a) Air at 20 °C ( $\rho = 1.205 \text{ kg/m}^3$ ,  $\nu = 15.06 \times 10^{-6} \text{ m}^2/\text{s}$ ,  $D = 4.166 \times 10^{-5} \text{ m}^2/\text{s}$ ), flows over a tray (length = 320 mm, width = 420 mm) full of water with a velocity of 2.8 m/s. The total pressure of moving air is 1 atm and the partial pressure of water present in the air is 0.0068 bar. If the temperature of the water surface is 15 °C, Calculate the evaporation rate of water.

$$D_{AB} = D_{\text{H}_2\text{O-air}} = 1.87 \times 10^{-10} \frac{T^{2.072}}{P}$$

$$Sc = \frac{\nu}{D_{AB}}$$

$$Sh = 0.15(Gr Sc)^{1/3}$$

$$h_{\text{mass}} = \frac{\text{Sh}D_{AB}}{L_c}$$

$$\dot{m}_v = h_{\text{mass}} A_s (\rho_{v,s} - \rho_{v,\infty})$$

$$\dot{Q}_{\text{evap}} = \dot{m}_v h_{fg}$$

