



SNS COLLEGE OF TECHNOLOGY



AN AUTONOMOUS INSTITUTION

**Approved by AICTE New Delhi & Affiliated to Anna University Chennai
Accredited by NBA & Accredited by NAAC with “A+” Grade, Recognized by UGC**

COIMBATORE

DEPARTMENT OF CIVIL ENGINEERING

19GET102 – BASIC CIVIL AND MECHANICAL ENGINEERING

I YEAR / I SEMESTER

Unit 1 : Civil Engineering Materials and Surveying

Topic : Tests on Stones



Tests on Stones

- There are various tests on building stones to know its properties and suitability for various construction works.
- Tests on building stones provides physical and chemical properties as well as strength and hardness properties.



Tests on Stones

Following are different tests on building stones:

1. Acid test
2. Attrition test
3. Crushing test
4. Crystalline test
5. Freezing and thawing test
6. Hardness Test
7. Impact test
8. Water absorption test
9. Microscopic Test
10. Smith's Test



Acid Test

- This test is carried out to understand the presence of **calcium carbonate** in building stone.
- A sample of stone weighing about 50 to 100 gm is taken.
- It is placed in a solution of **hydrochloric acid** having strength of one percent and is kept there for seven days. Solution is agitated at intervals.
- A good building stone maintains its sharp edges and keeps its surface free from powder at the end of this period.
- If the edges are broken and powder is formed on the surface, it indicates the presence of calcium carbonate and such a stone will have poor weathering quality.
- This test is usually carried out on sandstones.



Acid Test





Attrition Test

- This test is done to find out the rate of wear of stones, which are used in road construction.
- The results of the test indicates the resisting power of stones against the grinding action under traffic.

The following procedure is adopted:

- ❖ Samples of stones is broken into pieces about 60mm size.
- ❖ Such pieces, weighing 5 kg are put in both the cylinders of Deval's attrition test machine. Diameter and length of cylinder are respectively 20 cm and 34 cm.



Attrition Test





Attrition Test

- ❖ Cylinders are closed. Their axes make an angle of 30 degree with the horizontal.
- ❖ Cylinders are rotated about the horizontal axis for 5 hours at the rate of 30 rpm.
- ❖ After this period, the contents are taken out from the cylinders and they are passed through a sieve of 1.5mm mesh.
- ❖ Quality of material which is retained on the sieve is weighed.
- ❖ Percentage wear worked out as follows:

$$\text{Percentage wear} = (\text{Loss in Weight}/\text{Initial Weight}) \times 100$$

- Maximum abrasion value is 30%



Crushing Strength Test

- ✓ For conducting this test, a specimen of size $40 \times 40 \times 40$ mm is prepared from parent stone.
- ✓ Afterward, the sides are finely dressed and placed in water for three days.
- ✓ The saturated specimen is provided with a layer of Plaster of Paris on its top also bottom surfaces to get even surface so that load applied is distributed uniformly.
- ✓ Uniform load distribution could be obtained satisfactorily by providing a pair of 5 mm thick plywood instead of using Plaster of Paris layer also.
- ✓ The specimen so placed in the compression testing machine is loaded in the rate of 14 N/mm^2 per minute. The crushing load is noted.
- ✓ Then crushing strength is equal to this crushing load divided by the area where the load is applied.
- ✓ At least three specimens must be tested, and the average ought to be taken as crushing strength.



Crushing Strength Test

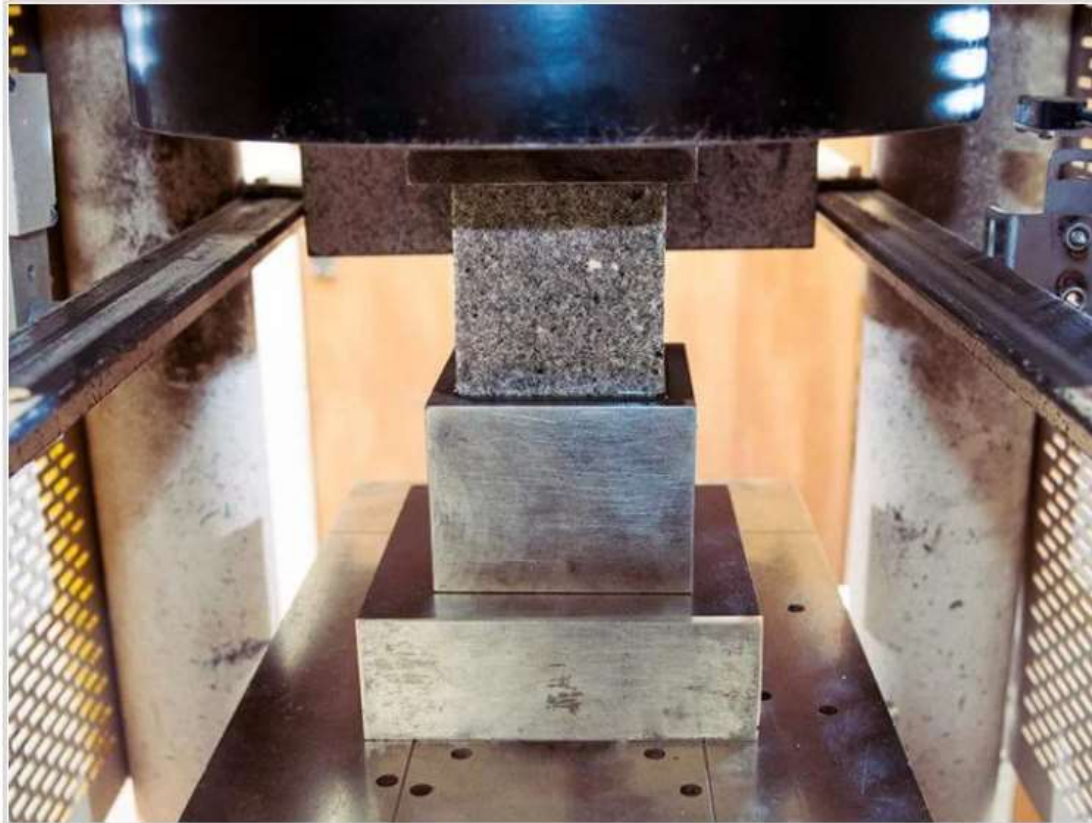



Crystalline Test

- To determine the durability or weathering quality of the stone.
- At least four cubes of stone with side as 40 mm are taken. They are dried for 72 hours and weighted.
- They are then immersed in a 14% solution of Na_2SO_4 for 2 hours.
- They are dried at 100 degrees C and weighted. The difference in weight is noted.
- This the procedure of drying, weighing, immersion, and reweighting is repeated at least 5 times.
- Each time, a change in weight noted, and it is expressed as a percentage of the original weight.



Freezing and Thawing Test

- Stone specimen is kept immersed in water for 24 hours.
- It is then placed in a freezing machine at -12 deg C for 24 hours.
- Then it is thawed or warmed at atmospheric temperature.
- This should be done in shade to prevent any effect due to wind, sun rays, rain etc. this procedure is repeated several times and the behaviour of stone is carefully observed.



Hardness Test

For determining the hardness of a stone, the test is carried out as follows:

- ✓ A cylinder of diameter 25mm and height 25mm is taken out from the sample of stone.
- ✓ It is weighed.
- ✓ The sample is placed in **Dorry's testing machine** and it is subjected to a pressure of 1250 gm.
- ✓ Annular steel disc machine is then rotated at a speed of 28 rpm.
- ✓ During the rotation of the disc, coarse sand of standard specification is sprinkled on the top of disc.
- ✓ After 1000 revolutions, specimen is taken out and weighed.
- ✓ The coefficient of hardness is found out from the following equation:

$$\text{Coefficient of hardness} = 20 - (\text{Loss of weight in gm}/3)$$



Hardness Test





Impact Test

The resistance of stones to impact is found by conducting tests in impacting the testing machine.

- ✓ A cylinder of diameter 25mm and height 25mm is taken out from the sample of stone.
- ✓ It is placed on the machine. And taken a 2kg stone sample at 24 hours put in the oven.
- ✓ Fill the cylinder cup in three-layer.
- ✓ Each layer 25 times compacted.
- ✓ Take the weight of the cylinder.
- ✓ Falling the hammer 15-time blow allowed to fall axially in a vertical direction over a specimen in an impact testing machine.
- ✓ The Hight of the first blow is 1cm, that of the second below 2cm, that of the third below 3cm.



Impact Test





Impact Test

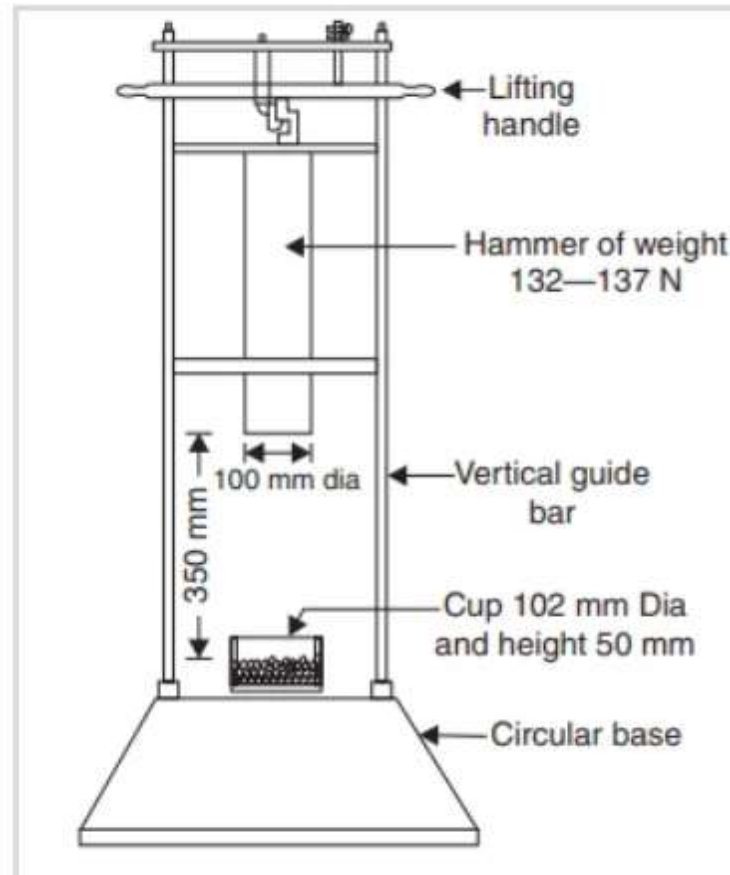



Impact Test

- ✓ Blow at which specimen breaks is noted. If it is nth blow, 'n' represents the **toughness index of stone.**

$$\text{Impact value} = w2 * 100 / W1$$

- Where, W1 = passing stone in a 12.5mm sieve before falling hammer
- w2 = after falling hammer wt. of stone



Microscopic Test

- The sample of the test is subjected to microscopic examination.
- The sections of stones are taken and placed under the microscope to study the various properties such as
 - Average grain size
 - Existence of pores, fissures, veins and shakes
 - Mineral constituents
 - Nature of cementing material
 - Presence of any harmful substance
 - Texture of stones etc.



Smith's Test

- This test is performed to find out the presence of soluble matter in a sample of stone.
- Few chips or pieces of stone are taken and they are placed in a glass tube.
- The tube is then filled with clear water.
- After about an hour, the tube is vigorously stirred or shaken.
- Presence of earthy matter will convert the clear water into dirty water.
- If water remains clear, stone will be durable and free from any soluble matter.



Water Absorption Test

- With this test **cube specimen weighing about 50 grams** are Ready, and the test is carried out at the steps given below:
 - Note the weight of dry specimens as **W1**.
 - Place the specimen in water for **24 hours**.
 - Take out the specimen, wipe out the surface with a piece of cloth, and weigh the specimen. Let its weight be **W2**.
 - Suspend the specimen freely in weight and water it. Let its weight be **W3**.
 - Place the specimen in boiling water for **5 hours**.
 - Then take it out, wipe the surface with a cloth, and weigh it. Let this weight be **W4**.
- Then,



Water Absorption Test

- Percentage absorption by weight = $(W_2 - W_1) / W_1 \times 100$ (1)
- Percentage absorption by volume = $(W_2 - W_1) / (W_2 - W_3) \times 100$ (2)
- Percentage porosity by volume = $(W_4 - W_1) / (W_2 - W_3) \times 100$ (3)
- Density = $W_1 / (W_2 - W_1) \times 100$ (4)
- Specific Gravity = $W_1 / (W_2 - W_3) \times 100$ (5)
- Saturation Coefficient = Water Absorption / Total Porosity = $(W_2 - W_1) / (W_4 - W_1)$



Thank You!!