



# **SNS COLLEGE OF TECHNOLOGY**

Kurumbapalayam (Po), Coimbatore – 641 107

**An Autonomous Institution**

Accredited by NBA – AICTE and Accredited by NAAC – UGC with 'A' Grade  
Approved by AICTE, New Delhi & Affiliated to Anna University, Chennai

## **DEPARTMENT OF ELECTRONICS AND COMMUNICATION ENGINEERING**

**COURSE NAME : 19ECB201-ANALOG ELECTRONIC CIRCUITS**

**II YEAR /III SEMESTER**

**Unit 4- OSCILLATORS & MULTIVIBRATOR CIRCUITS**

**Topic 4 : RC Phase Shift and Wein Bridge Oscillators**





# Application of Oscillators



- Communication Systems
- Control signals

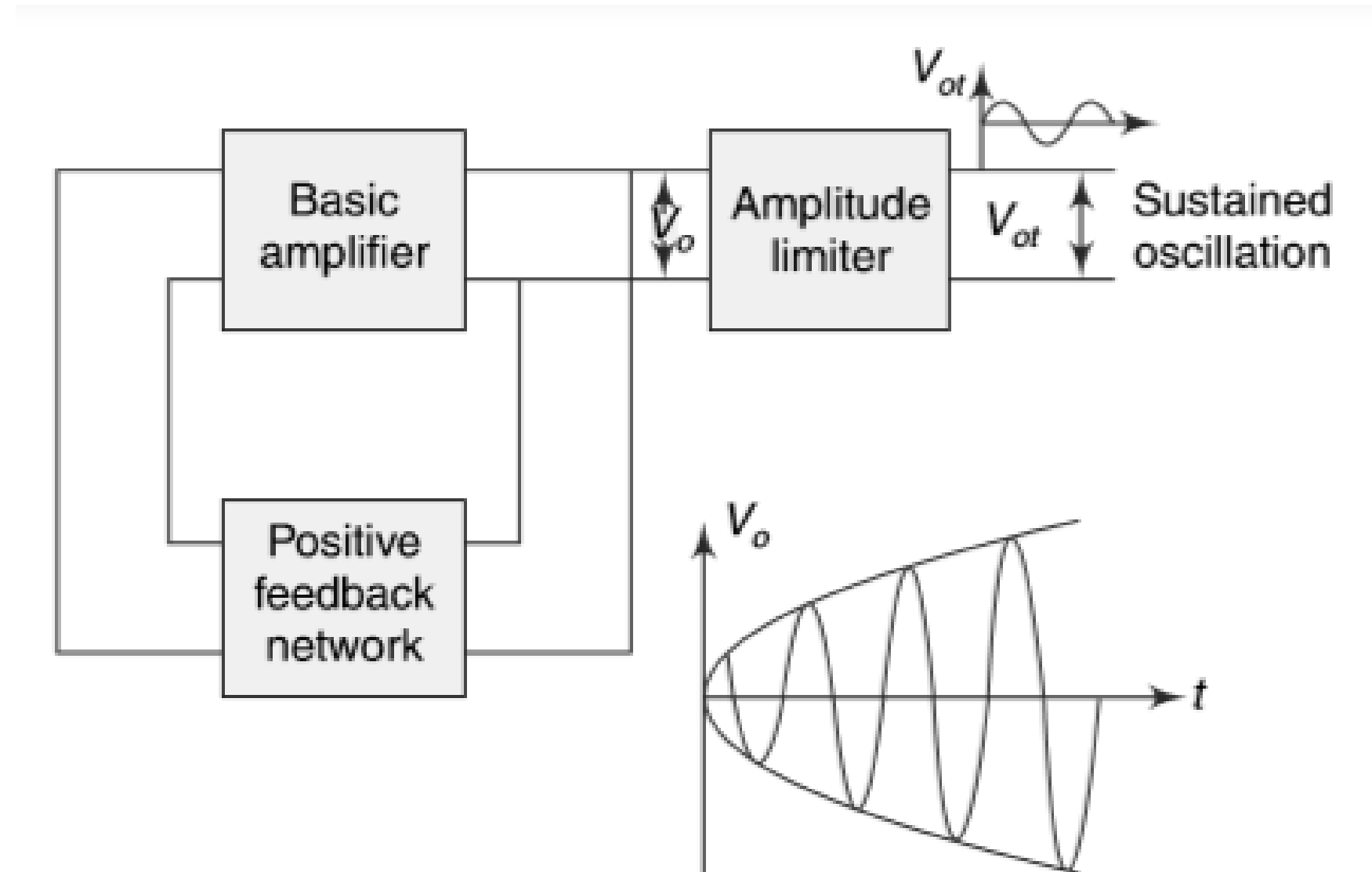



# RC Phase Shift Oscillator Circuit



- NPN transistor
- Conditions for oscillations
- Positive Feedback

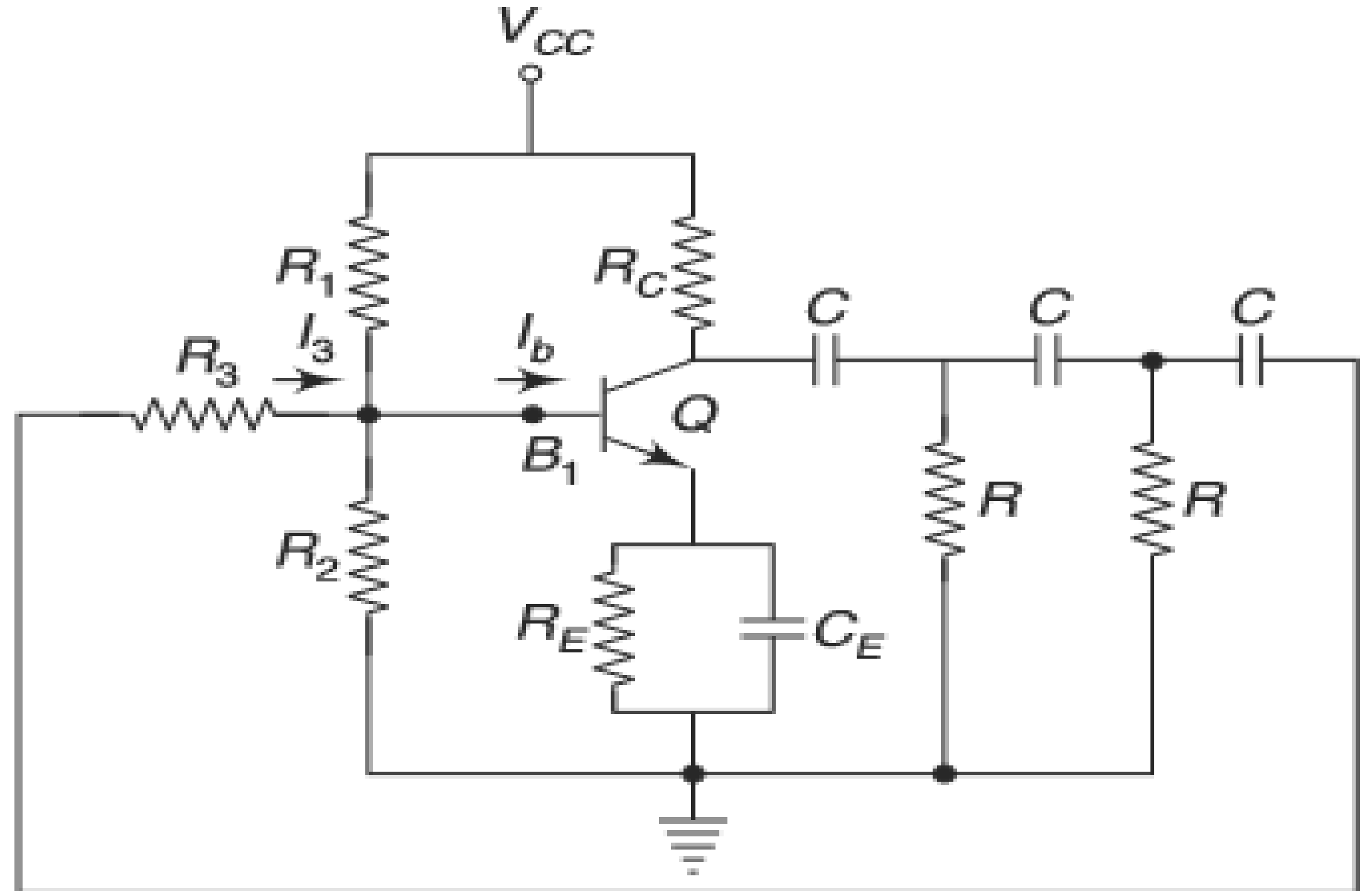



# Mechanism of Start of Oscillation

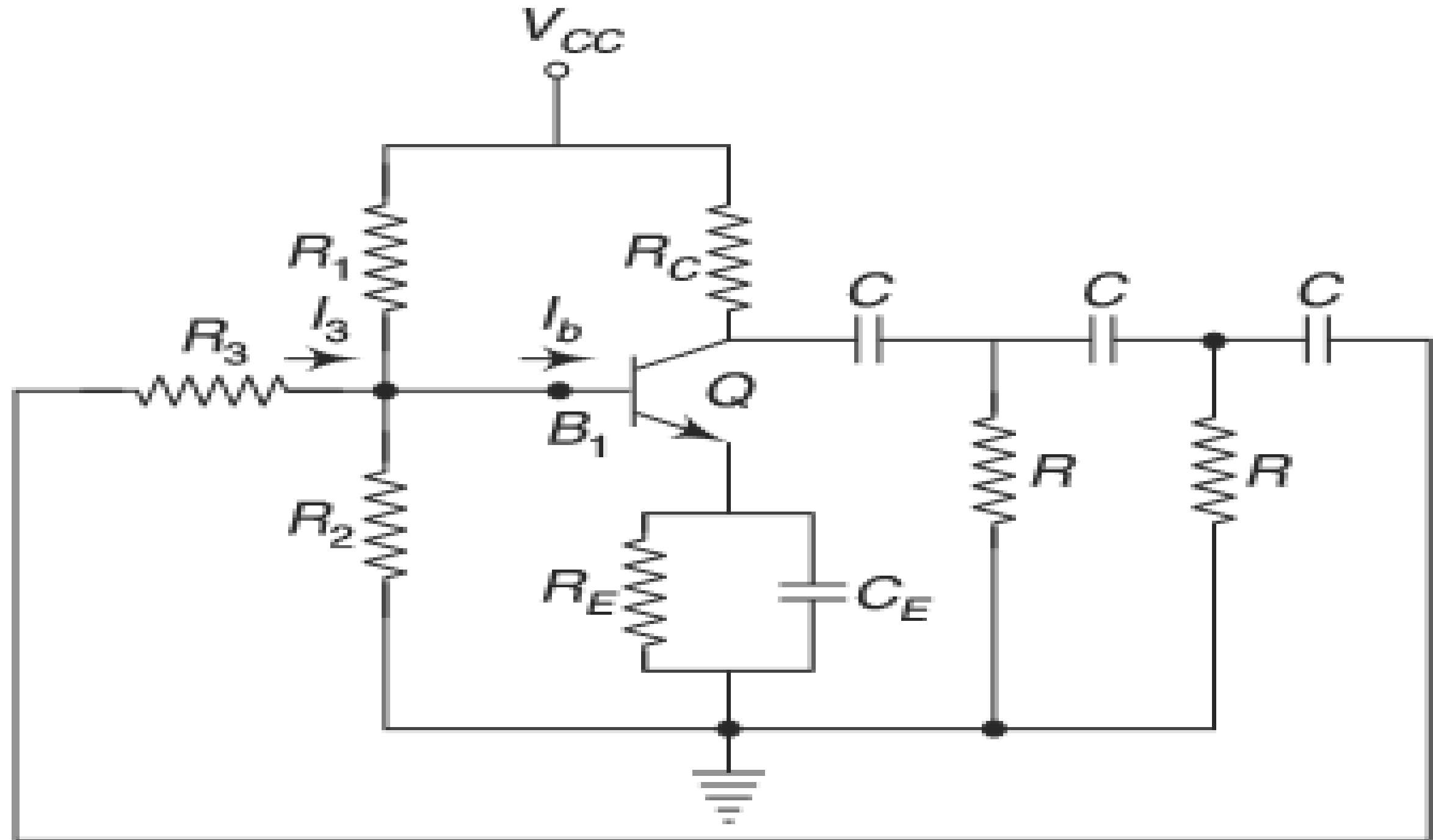



# Stabilization of Amplitude

Amplitude Limiting

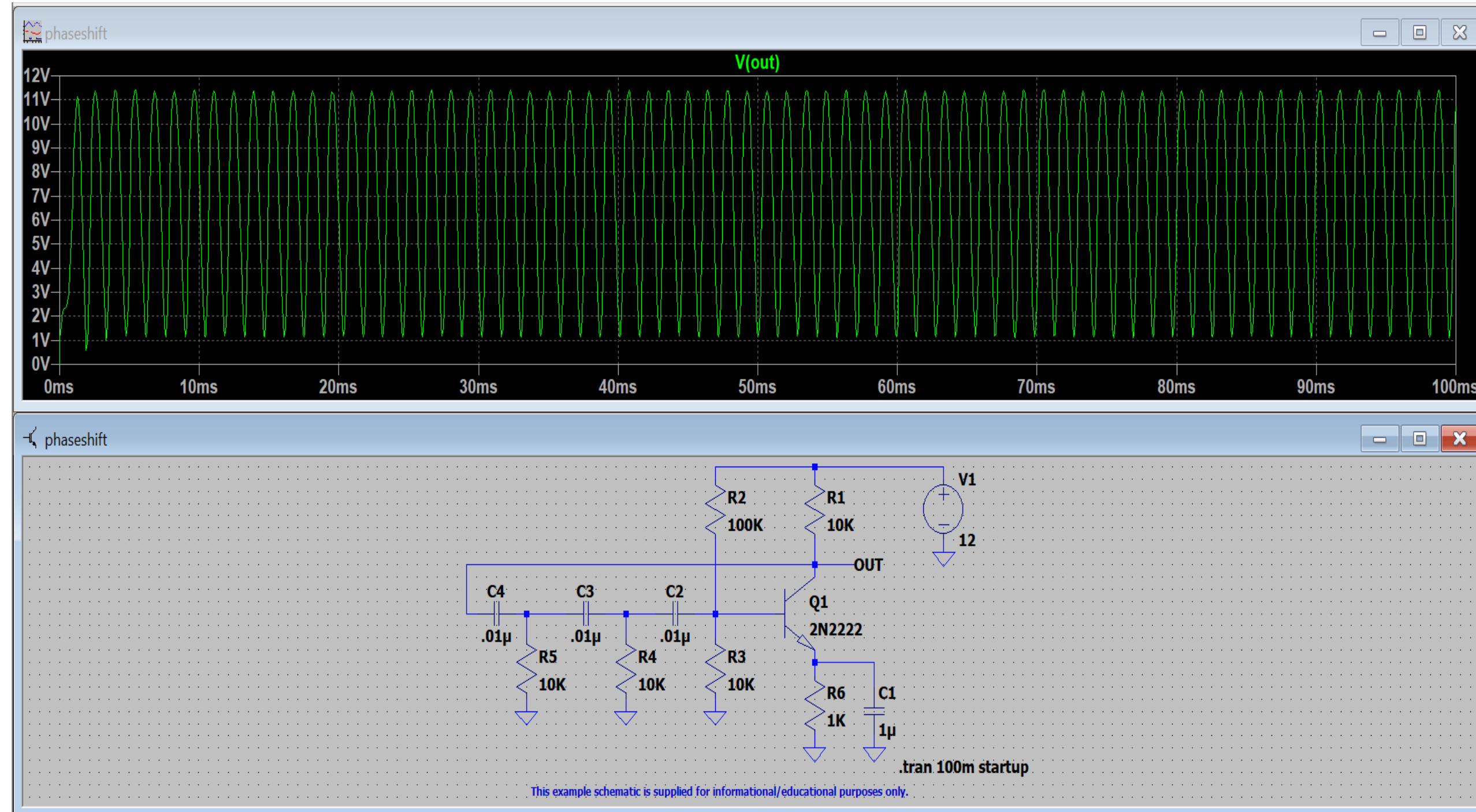



# Frequency of Oscillation

$$f_o = \frac{1}{2\pi RC\sqrt{6}}$$

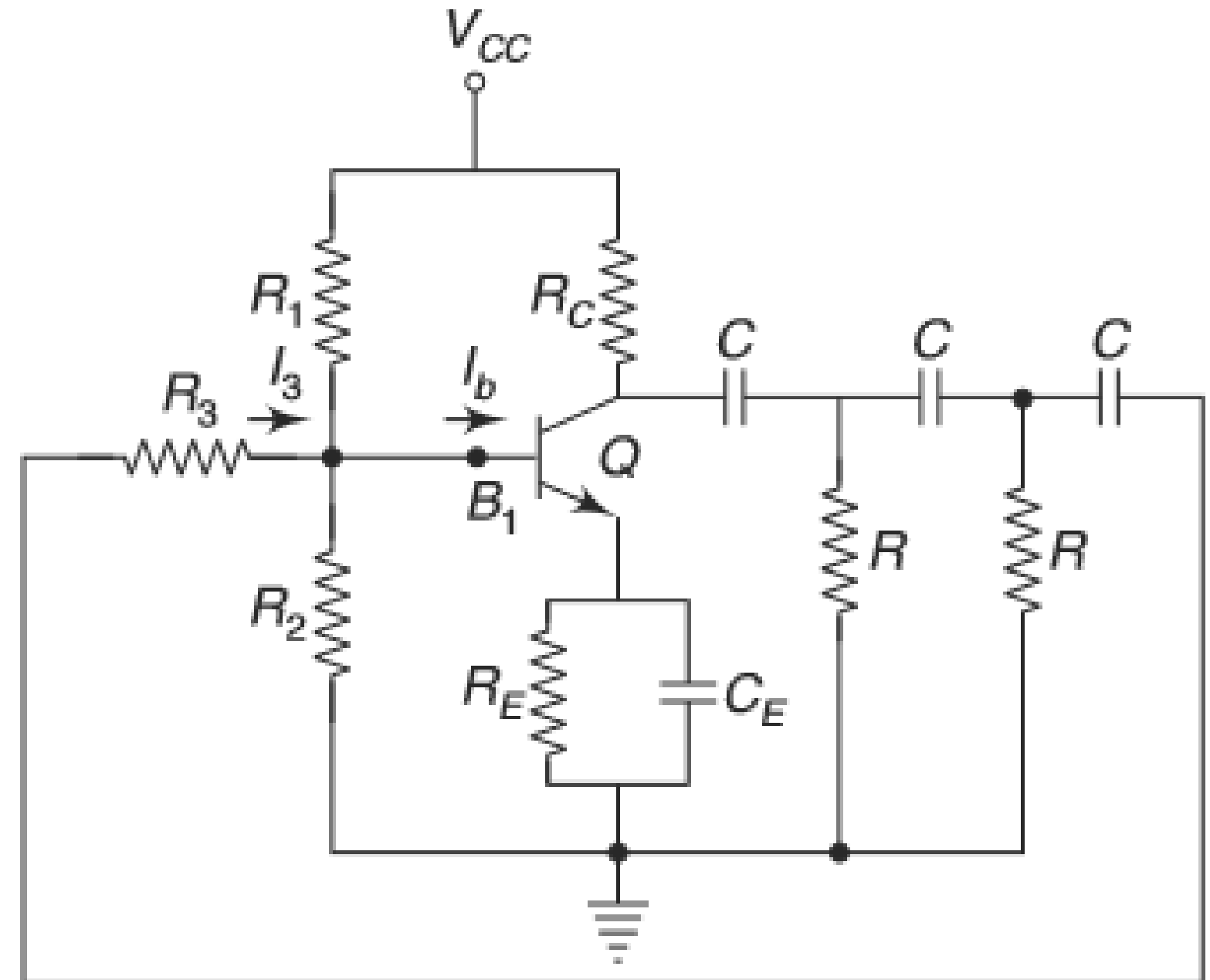



## Role of RC Network

Phase shift of each RC stage is 60 degree

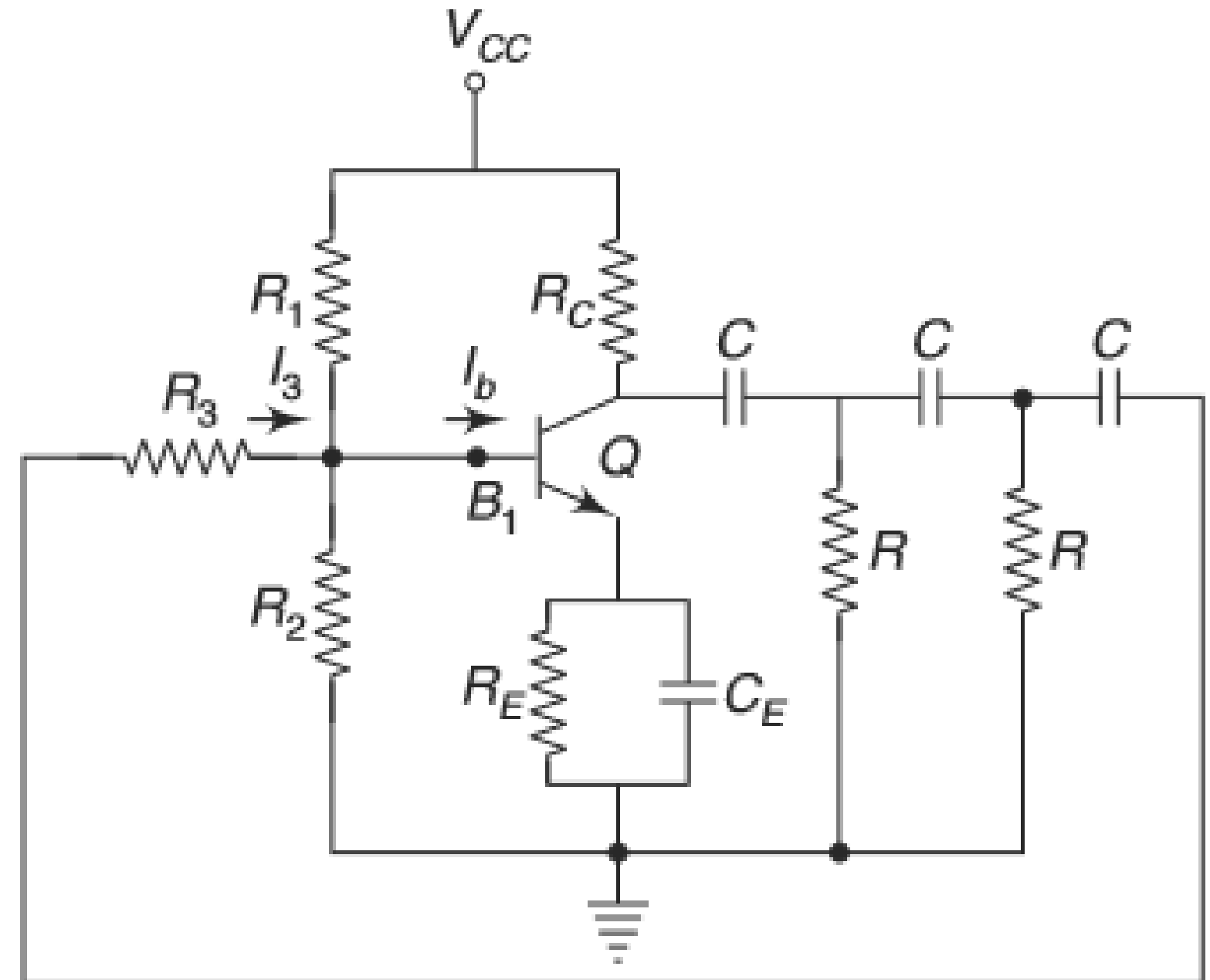



# Amplitude Limiting by RC Stages



Signal compressed by RC stages

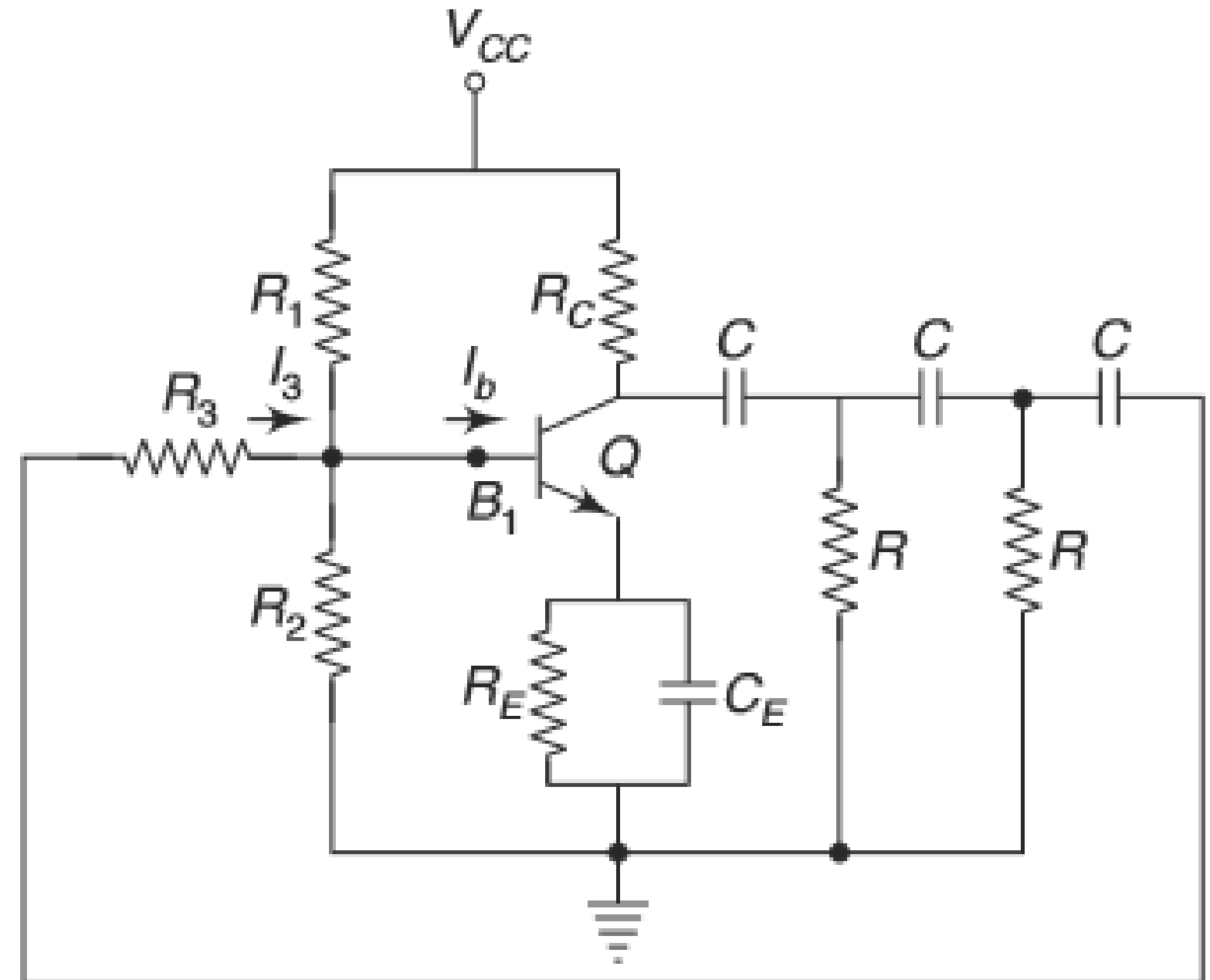





# Wein Bridge Oscillator

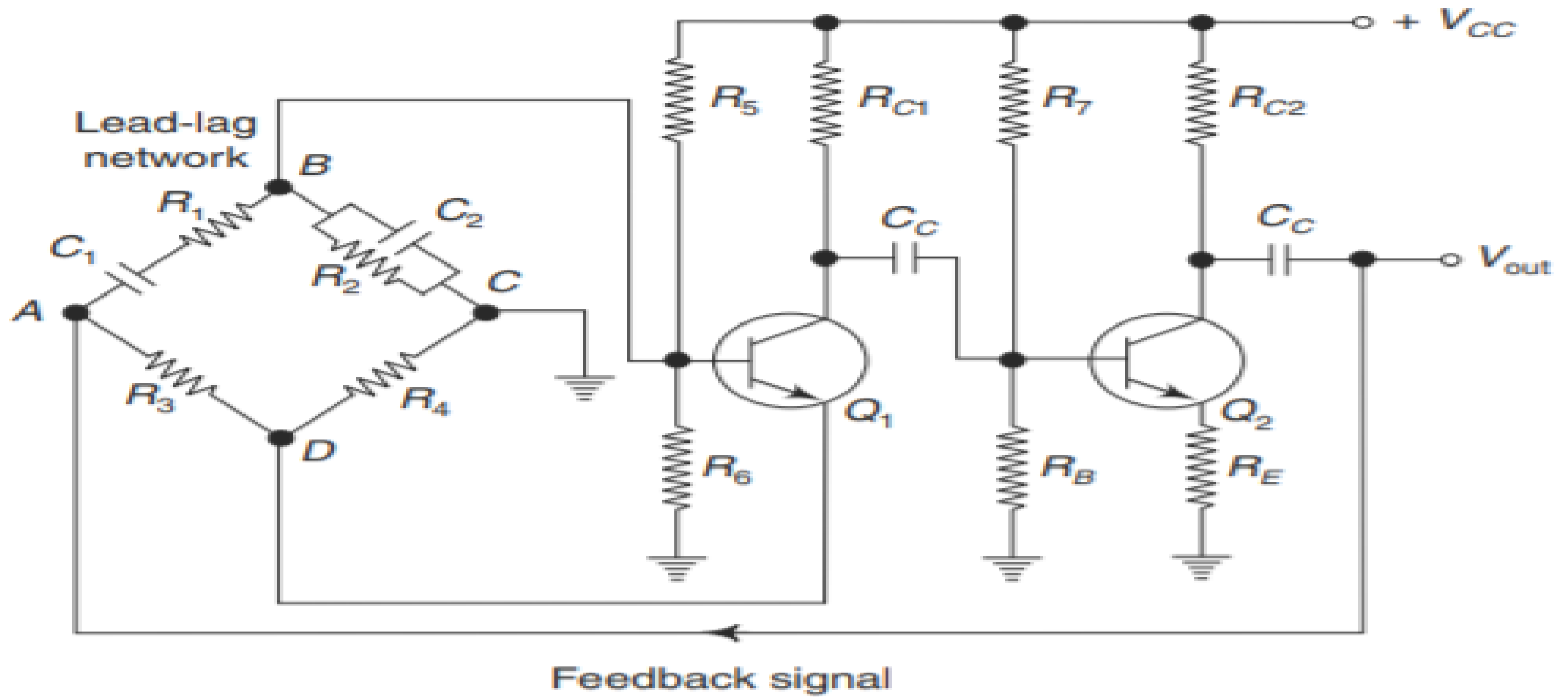



# Wein Bridge Oscillator



- The feedback network consists of a lead-lag network ( $R_1 - C_1$  and  $R_2 - C_2$ ) and a voltage divider ( $R_3 - R_4$ ).

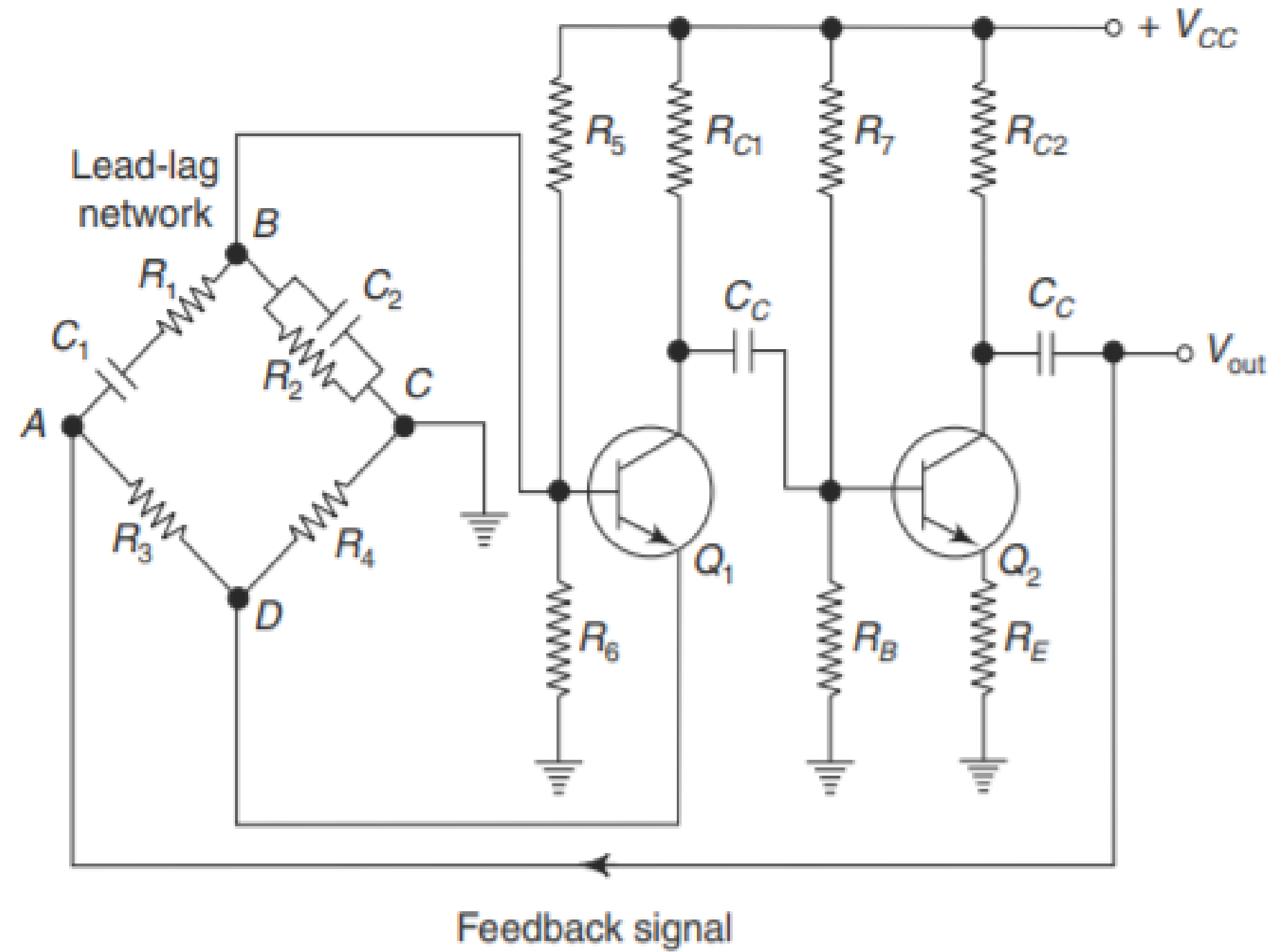



# Wein Bridge Oscillator

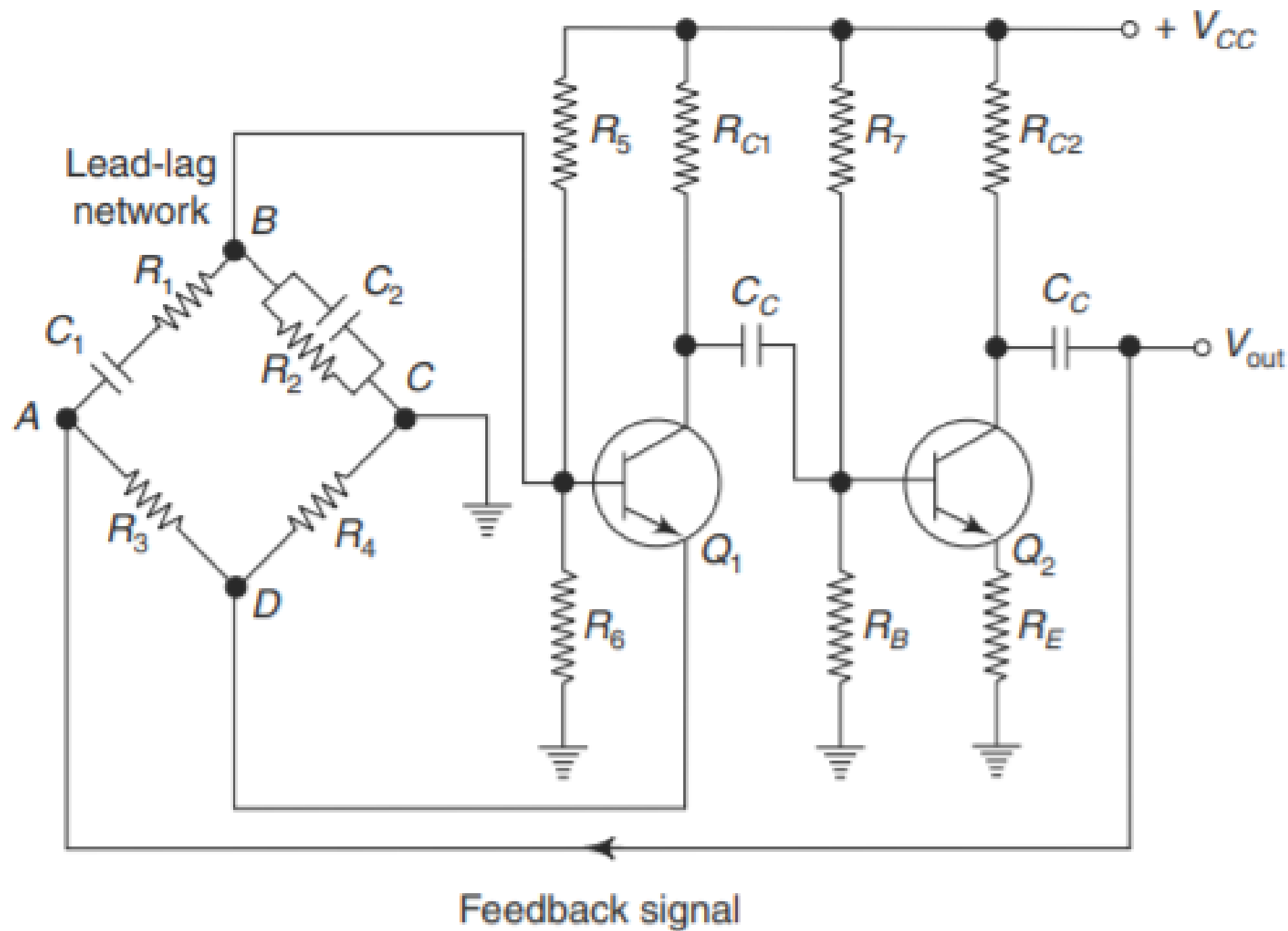

- The lead-lag network provides a positive feedback to the input of the first stage and the voltage divider provides a negative feedback to the emitter of Q1.



# Frequency of Oscillation

$$f_o = \frac{1}{2\pi\sqrt{R_1 R_2 C_1 C_2}}$$

$$= \frac{1}{2\pi RC}, \text{ if } R_1 = R_2 = R \text{ and } C_1 = C_2 = C.$$



# Problem-I



In an RC phase shift oscillator, if  $R_1 = R_2 = R_3 = 200 \text{ k}\Omega$  and  $C_1 = C_2 = C_3 = 100 \text{ pF}$ . Find the frequency of oscillations.

The frequency of an RC phase shift oscillator is given by

$$\begin{aligned} f_o &= \frac{1}{2\pi RC\sqrt{6}} \\ &= \frac{1}{2\pi \times 200 \times 10^3 \times 100 \times 10^{-12} \sqrt{6}} \\ &= 3.248 \text{ kHz} \end{aligned}$$



## Problem-II



In a Wien-bridge oscillator, if the value of  $R$  is  $100 \text{ k}\Omega$ , and frequency of oscillation is  $10 \text{ kHz}$ , find the value of capacitor  $C$ .

*Solution* The operating frequency of a Wien-bridge oscillator is given by

$$f_o = \frac{1}{2\pi RC}$$

Therefore,

$$C = \frac{1}{2\pi R f_o}$$
$$= \frac{1}{2\pi \times 100 \times 10^3 \times 10 \times 10^3} = 159 \text{ pF}$$



# Assessment 1



Determine the frequency of oscillations when a RC phase-shift oscillator has  $R = 10 \text{ k}\Omega$ ,  $C = 0.01 \text{ }\mu\text{F}$  and  $R_C = 2.2 \text{ k}\Omega$ . Also, find the minimum current gain needed for this purpose.





# References



Electronic Devices and Circuits By Salivahanan

**Thank You**