



# **SNS COLLEGE OF TECHNOLOGY**

## **An Autonomous Institution**

### **Coimbatore-35**



Accredited by NBA – AICTE and Accredited by NAAC – UGC with 'A+' Grade  
Approved by AICTE, New Delhi & Affiliated to Anna University, Chennai

## **DEPARTMENT OF ELECTRONICS & COMMUNICATION ENGINEERING**

### **19ECB301-ANALOG AND DIGITAL COMMUNICATION**

III YEAR/ V SEMESTER

#### **UNIT 2 – RADIO TRANSMITTER & RECEIVER**

TOPIC – RECEIVER TYPES-AM RECEIVERS

---



## RADIO RECEIVER



- Intercept the electromagnetic waves in the receiving antenna to produce the desired RF modulated carrier.
- Select the desired signal and reject the unwanted signal.
- Amplify the RF signal.
- Detect the RF carrier to get back the original modulation frequency voltage.
- Amplify the modulation frequency voltage



## FEATURES OF RECEIVER



- Simplicity of operation
- Good fidelity
- Good selectivity
- Average sensitivity
- Adaptability to different types of aerials



## FEATURES OF RECEIVER

If receiver has poor selectivity.....





## FEATURES OF RECEIVER

If receiver has poor sensitivity....

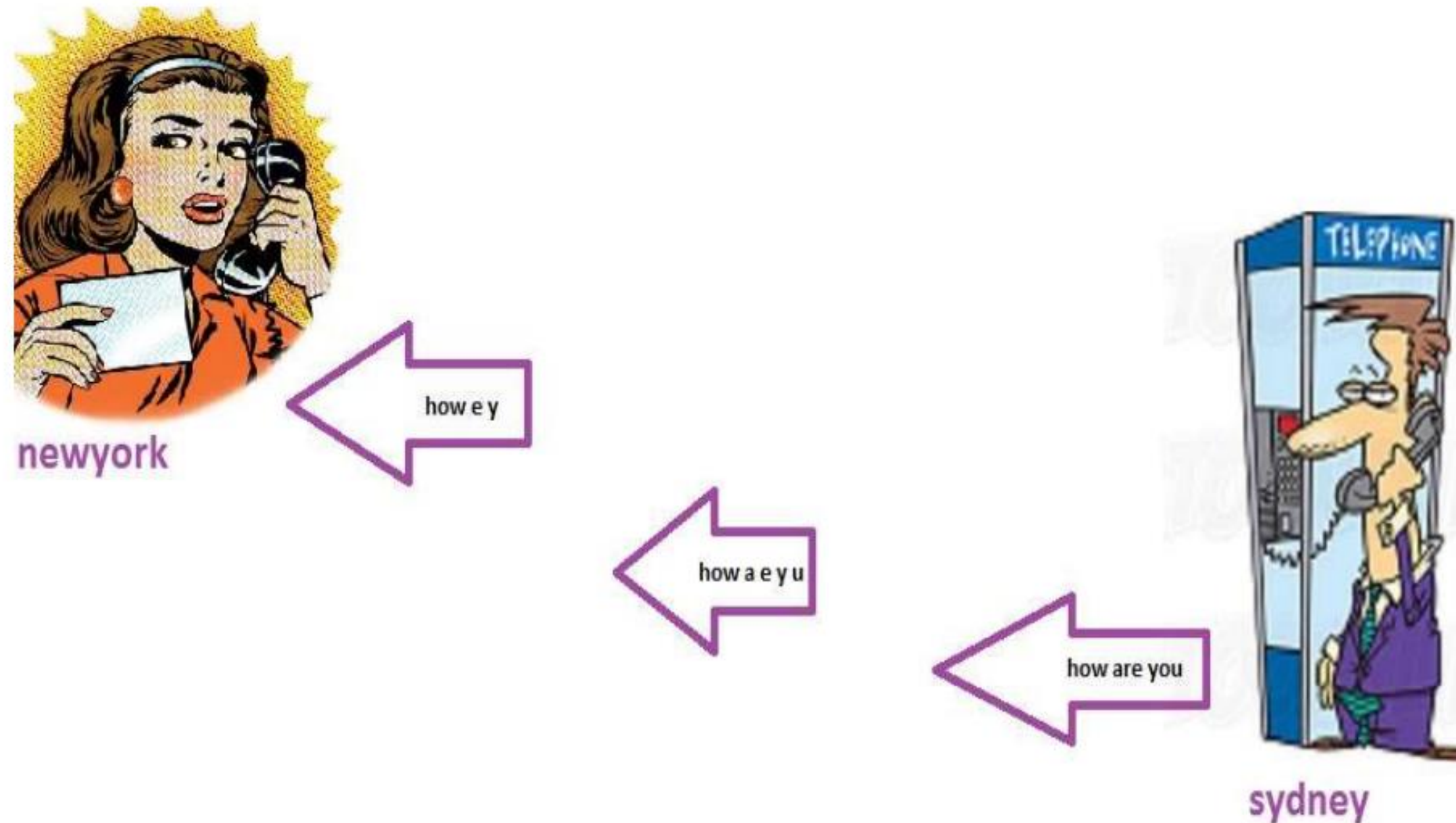



## FEATURES OF RECEIVER



If receiver has poor fidelity...





## AM RADIO RECEIVER



Radio receiver is an electronic equipment which picks up the desired signal, reject the unwanted signal and demodulate the carrier signal to get back the original modulating signal.





# AM RADIO RECEIVER



## Function of Radio-receiver

- Select desired signal and reject unwanted signal
- Amplify the R.F. signal
- Demodulate the selected signal





# TYPES OF AM RADIO RECEIVER



## Types of AM-Receiver

1. TRF-Receiver
2. Superhetrodyne AM-Receiver

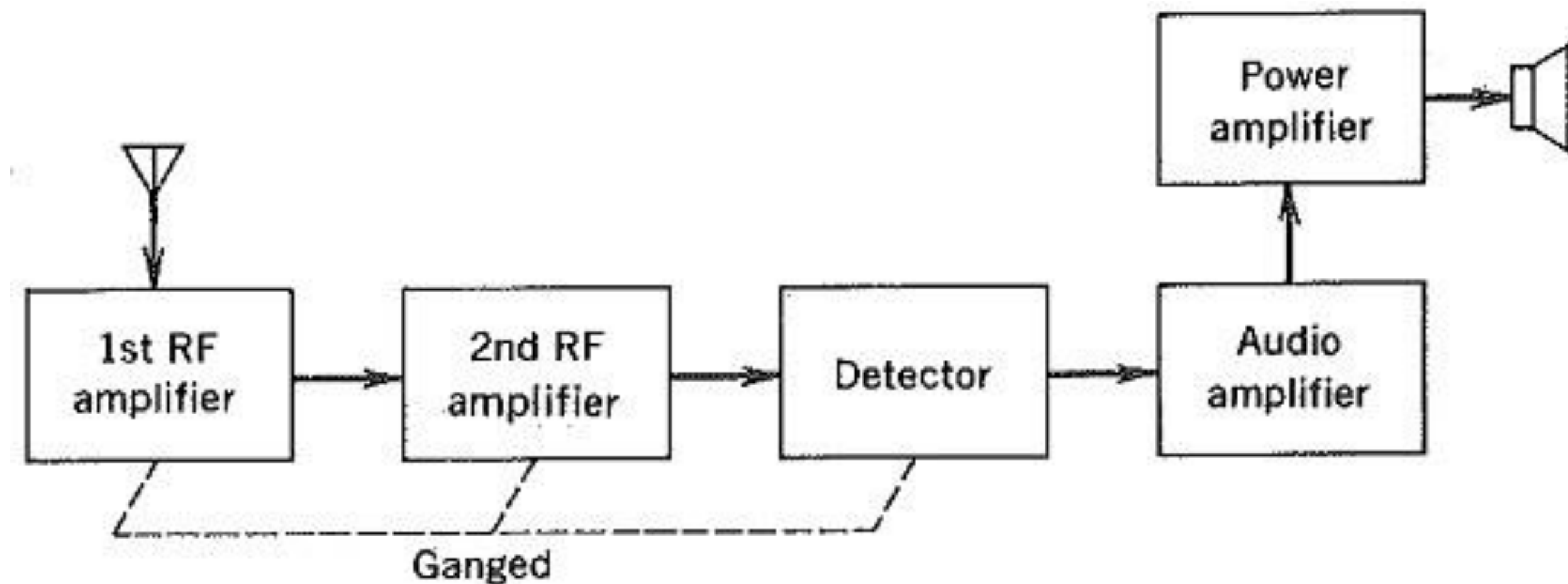

**The TRF receiver.**



## TUNED RADIO FREQUENCY RECEIVER



A tuned radio frequency receiver (or TRF receiver) is a type of radio receiver that is usually composed of one or more tuned radio frequency (RF) amplifier stages followed by a detector (demodulator) circuit to extract the audio signal and an audio frequency amplifier. Popular in the 1920s, it could be tedious to operate because each stage must be individually tuned to the station's frequency. By the mid 1930s it was replaced by the superheterodyne receiver invented by Edwin Armstrong



# TUNED RADIO FREQUENCY RECEIVER





## WORKING OPERATION



**The classic TRF receivers of the 1920s and 30s consisted of three sections:**

- One or more tuned RF amplifier stages. These amplify the signal of the desired station to a level sufficient to drive the detector, while rejecting all other signals picked up by the antenna
- a detector, which extracts the audio (modulation) signal from the radio carrier signal by rectifying it
- optionally, but almost always included, one or more audio amplifier stages which increase the power of the audio signal



## ADVANTAGES



- They amplify defined frequency.
- Signal to noise ratio at output is good.
- They are well suited for radio transmitters and receiver.
- The band of frequency over which amplification is required can be varied



## DISADVANTAGES



- Since they used inductor and capacitor as tuning the element, the circuit is bulky and costly.
- They are not suitable to amplify audio frequencies
- If the band of the frequency is increased, design become complex



# SUPERHETERODYNE RECEIVER

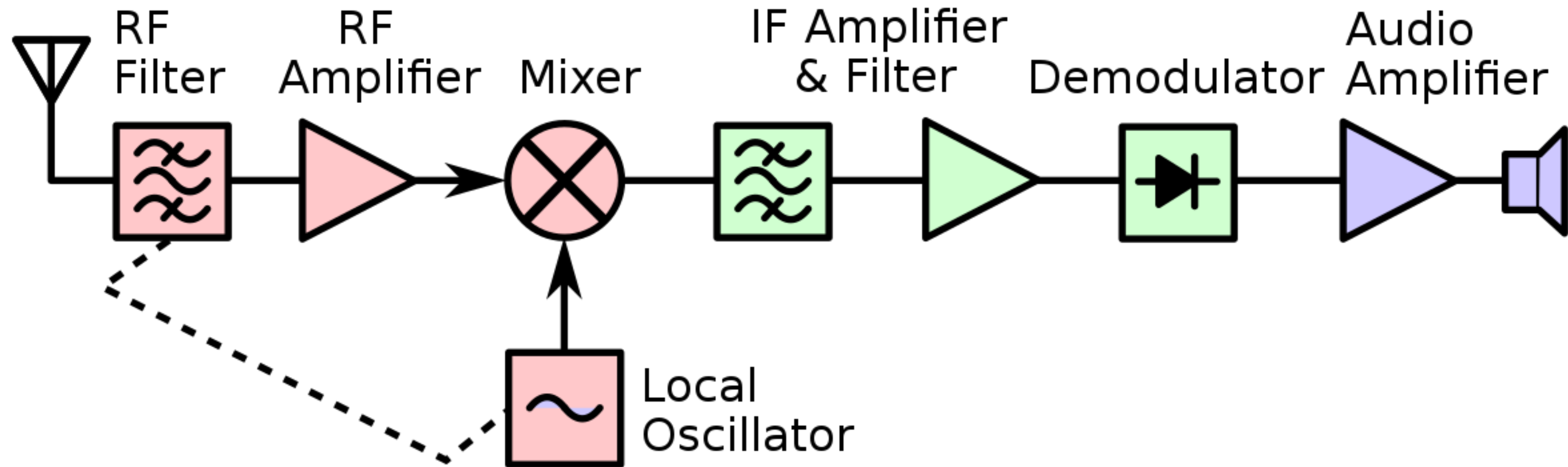



# SUPERHETERODYNE RECEIVER



## FRONT END AMPLIFIER AND TUNING BLOCK

- To receive a radio signal a suitable antenna is required.
- Signal enter the front end circuitry from the antenna.
- This circuit block performs two main functions.
- ❑ **TUNING**:- Broad band tuning is applied to RF (radio frequency)stage. The purpose of this to reject the signals on the image frequency and accept those on the wanted frequency.
  - It must also be able to track the local oscillator so that as the receiver is tuned, so the RF tuning remains on the required frequency.
  - Typically the selectivity provided at this stage is not high.
  - Its main purpose is to reject signals on the image frequency which is at a frequency equal to twice that of the IF away from the wanted frequency.
- ❑ **AMPLIFICATION**:- In amplification, the level is carefully chosen so that it does not overload the mixer when strong signals are present. But enables the signals to be amplified sufficiently to ensure a good signal to noise ratio is achieved.
  - The amplifier must also be a low noise design.





# SUPERHETERODYNE RECEIVER



## LOCAL OSCILLATOR AND MIXER

- The signal is then fed into a circuit where it is mixed with a sine wave from a variable frequency oscillator known as the LOCAL OSCILLATOR(LO).
- The mixer uses a non-linear component to produce both sum and difference beat frequencies signals, each one containing the modulation contained in the desired signal.
- The output of the mixer may include the original RF signal at  $f_{RF}$ , the local oscillator signal at  $f_{LO}$ , and the two new heterodyne frequencies  $f_{RF} + f_{LO}$  and  $f_{RF} - f_{LO}$ .
- IF band pass filter removes all but the desired IF signal at  $f_{IF}$ . The IF signal contains the original modulation that the received radio signal had at  $f_{RF}$ .
- The frequency of the local oscillator  $f_{LO}$  is set so the desired reception radio frequency  $f_{RF}$  mixes to  $f_{IF}$ .
- There are two choices for the local oscillator frequency because the dominant mixer products are at  $f_{RF} \pm f_{LO}$ .
- If the local oscillator frequency is less than the desired reception frequency. It is called **LOW –SIDE INJECTION** ( $f_{IF} = f_{RF} - f_{LO}$ ).
- If the local oscillator is higher, then it is called **HIGH SIDE INJECTION** ( $f_{IF} = f_{LO} - f_{RF}$ ).



## SUPERHETERODYNE RECEIVER



- If  $f_{LO}$  is set to  $f_{RF} + f_{IF}$  then an incoming radio signal at  $f_{LO} + f_{IF}$  will also produce a heterodyne at  $f_{IF}$ . This is called the image frequency and must be rejected by the tuned circuits in RF stage.
- The image frequency is  $2f_{IF}$  higher than  $f_{RF}$ , so employing a higher IF frequency  $f_{IF}$  increases the receiver's image rejection without requiring additional selectivity in RF stage.
- To suppress the unwanted image the tuning of the RF stage and LO may need to track each other.
- The tracking can be done with a multi section variable capacitor some varactors driven by a common control voltage.
- A RF amplifier may have tuned circuits at both its input and its output. So three or more tuned circuits may be tracked.
- In practice the RF and LO frequencies need to track closely but not perfectly.



# SUPERHETERODYNE RECEIVER



## INTERMEDIATE FREQUENCY AMPLIFIER

- The stages of an intermediate frequency amplifier are tune to a fixed frequency that does not change as the receiving frequency changes.
- The IF amplifier is selective around its center frequency  $f_{IF}$ .
- Typically the IF center frequency  $f_{IF}$  is chosen to be less than the desired reception frequency  $f_{RF}$ .
- The choice has some performance advantages.
- FIRST, it is easier and less expensive to get high selectivity at a lower frequency, for the same bandwidth, a tuned circuit at a lower frequency needs a lower Q. stated another way, for the same filter technology a higher center stages to achieve the same selectivity bandwidth.
- SECOND, it is easier and less expensive to get high gain at a lower frequency.
- When used at high frequencies, many amplifiers show a constant gain-bandwidth product characteristic.



## SUPERHETERODYNE RECEIVER



- Usually the intermediate frequency is lower than the reception frequency  $f_{RF}$ , but in some modern receivers a higher IF frequency is used to minimize problems with image rejection or gain the benefits of fixed tuned stages.
- In early superhet's, the IF stage often a regenerative stage providing the sensitivity with fewer components, such superhet's were called super gainers or regenerodynes.
- ❖ To see how this operates in reality take the example of two signals, one at 6MHz and another at 6.1 MHz also take the example of IF situated at 1MHz.
- ❖ If the local oscillator is set to 5MHz the two signals generated by mixer as a result of 6 MHz signal fall at 1MHz and 11MHz. Naturally the 11MHz signal is rejected, but the one at 1MHz pass through the IF stage.
- ❖ The signal at 6.1MHz produces a signal at 1.1MHz and this falls outside bandwidth of the IF, so the only signal to pass through the IF is that from the signal 6MHz.



# SUPERHETERODYNE RECEIVER



## BANDPASS FILTER

- ❖ The IF stage includes a filter &- or multiple tuned circuits in order to achieve the desired selectivity.
- ❖ This filtering must therefore have a band pass equal to or less than the frequency spacing between adjacent broadcast channels.
- ❖ Ideally a filter would have a high attenuation to adjacent channels, but maintain a flat response across the desired signal spectrum in order to retain the quality of the received signals.
- ❖ This may be obtained using one or more dual tuned IF transformers, a quartz crystal filter, or a multiple ceramic crystal filter.



# SUPERHETERODYNE RECEIVER



## DEMODULATION

- ◆ The received signal is now processed by the demodulator stage where the audio signal is recovered and then further amplified.
- ◆ AM demodulator requires the simple rectification of the RF signal, and a simple RC low pass filter to remove remnants of the intermediate frequency.
- ◆ Different demodulators are required for different types of transmission, and they include,
  - **AM Diode detector**:- This is the most basic form of detector and this circuit block would simple consist of a diode and possibly a small capacitor to remove any remaining RF. The detector is cheap and its performance is adequate, requiring a sufficient voltage to overcome the diode forward drop.
  - **SYNCHRONOUS AM DETECTOR**:- This form of AM detector block is used in where improved performance is needed. It mixes the incoming AM signal with another on the same frequency as the carrier.



# SUPERHETERODYNE RECEIVER



- ❖ **SSB PRODUCT DETECTOR** - It consists of a mixer and a local oscillator, often termed a beat frequency oscillator (BFO) or carrier insertion oscillator (CIO). This form of detector is used for Morse code transmission where the BFO is used to create an audible tone in line with the one-off keying of the transmitter carrier.
- ❖ **BASIC FM DETECTOR** - As an FM signal carries no amplitude variations a demodulator block that senses frequency variations is required. It should also be insensitive to amplitude variations as these could add extra noise. Simple FM detectors such as the Foster Seeley or ratio detectors can be made from discrete components although they do require the use of transformers.
- ❖ **PLL FM DETECTOR** - A Phase locked loop can be used to make a good FM detector. The incoming FM signal can be fed into the reference input, and the VCO drive voltage used to provide the detected audio output.
- ❖ **QUADRATURE FM DETECTOR** - This form of FM detector block is widely used within IC's. It is simple to implement and provides good linear output.



# SUPERHETERODYNE RECEIVER



## AUDIO AMPLIFIER

- The output from the demodulator is the recovered audio.
- This is passed in to the audio stages where they are amplified and presented to the head phones or loud speakers.





## SUPERHETERODYNE RECEIVER



### ADVANTAGES AND DRAWBACKS OF THE SUPERHETERODYNE DESIGN

- ◆ Super heterodyne receiver have essentially replaced all previous receiver designs.
- ◆ The superhet receivers offers superior sensitivity, frequency stability and selectivity.
- ◆ Compared with the tuned radio frequency receiver design, superhet's offer better stability because tunable oscillator is more easily realized than a tunable amplifier.
- ◆ Operating at a lower frequency , IF filters can give narrower pass bands at the same Q factor than an equivalent RF filter.
- ◆ Regenerative and super regenerative receivers offered a high sensitivity. But often suffer from stability problems making them difficult to operate.



# SUPERHETERODYNE RECEIVER



## DRAWBACKS

### LOCAL OSCILLATOR RADIATION

- ◆ It is difficult to keep stray radiation from oscillator below the level that a nearby receiver can detect.
- ◆ The receiver's local oscillator can act like a low power CW transmitter.
- ◆ Consequently, there can be mutual interference in the operation of two or more superhet receivers in close proximity.
- ◆ The method of significantly reducing the local oscillator radiation from the receiver's antenna is to use an RF amplifier between the receiver's antenna and its mixer stage.



**THANK YOU**