



SNS COLLEGE OF TECHNOLOGY

(An Autonomous Institution)



COIMBATORE-35

Accredited by NBA-AICTE and Accredited by NAAC – UGC with A+ Grade
Approved by AICTE, New Delhi & Affiliated to Anna University, Chennai

UNIT 1

DEPARTMENT OF ELECTRICAL & ELECTRONICS ENGINEERING

Voltage Imbalance

19EEE307 – Power Quality Engineering
IV year / VII Semester

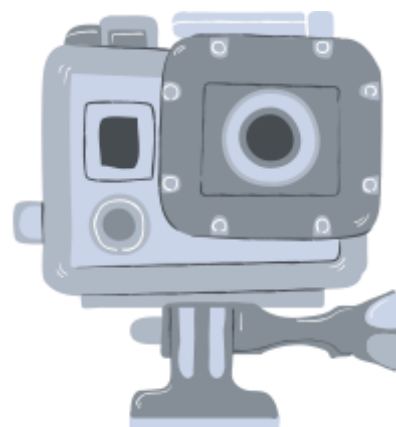

07.09.2022

19EET307 / PQE / S.Bharath / AP -EEE

01/10



INTRODUCTION



- It is a condition in which the voltages of the **three phases of the supply are not equal in magnitude**
- Magnitude may not even be equally displaced in time
- It is the cause of single phase loads in three phase circuits
- **Restricted to within 5%**



Voltage Imbalance

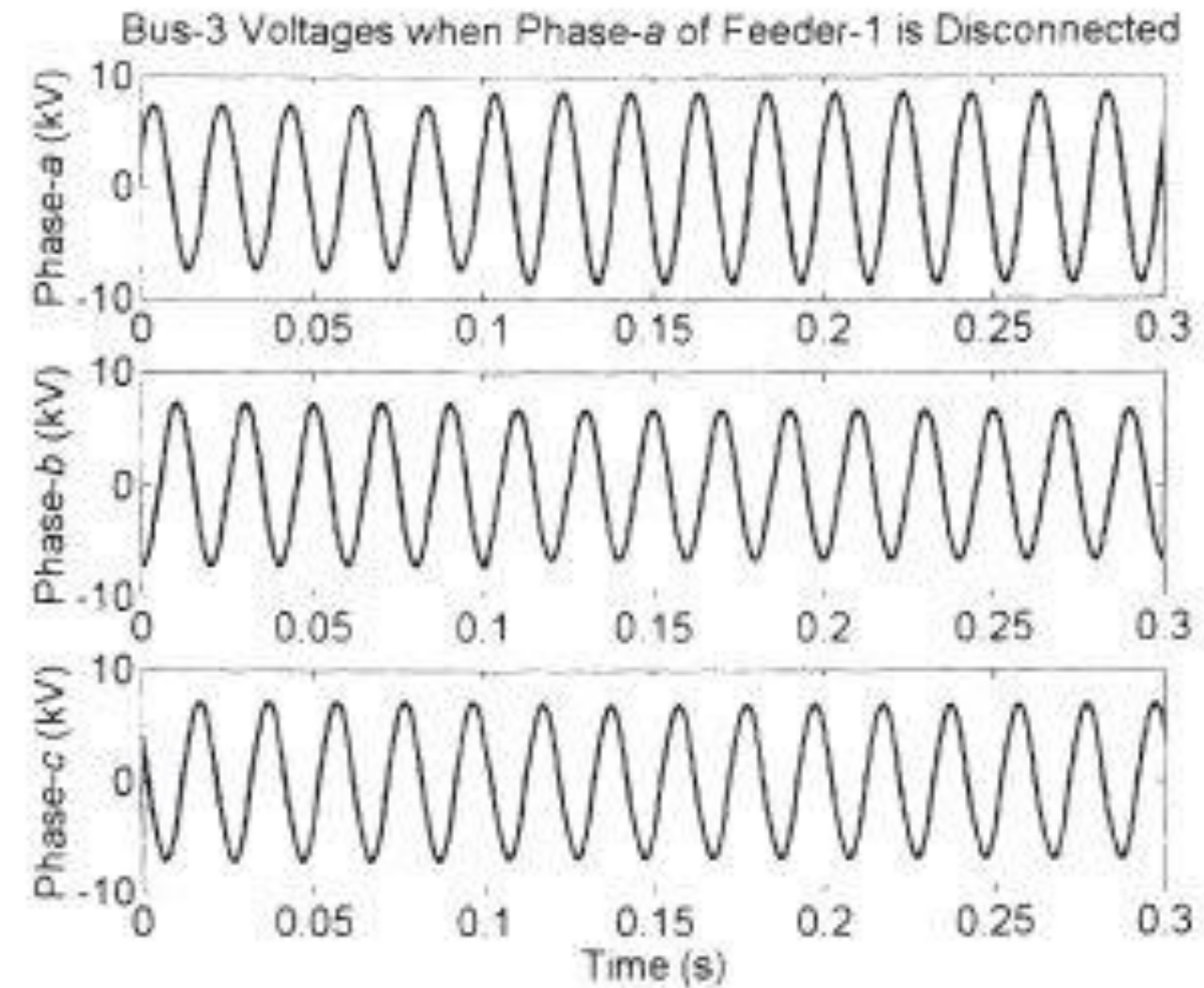
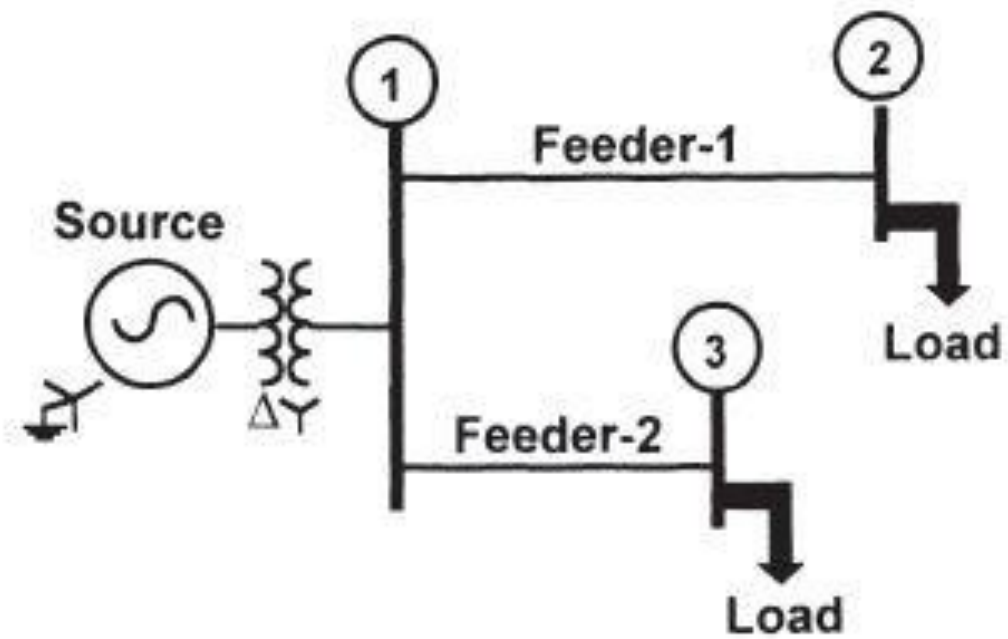



Voltage Fluctuation

- Systemic random variation in supply voltage
- Rapid change in supply voltage is called voltage flicker
- Caused by rapid variations in current magnitude of loads
- Flow of large inrush current causing voltage dip of the bus when the device is connected
 - Main cause of voltage flicker is arc loads like arc furnaces, arc welding and arc lamp
 - Melting cycle divided into three categories – Drilling (reduced voltage and power), Melting (full voltage and power) and Reheating period
 - Starting of large motors can cause the voltage to flicker, as it require a large inrush current during the starting

Causes



Voltage Fluctuations

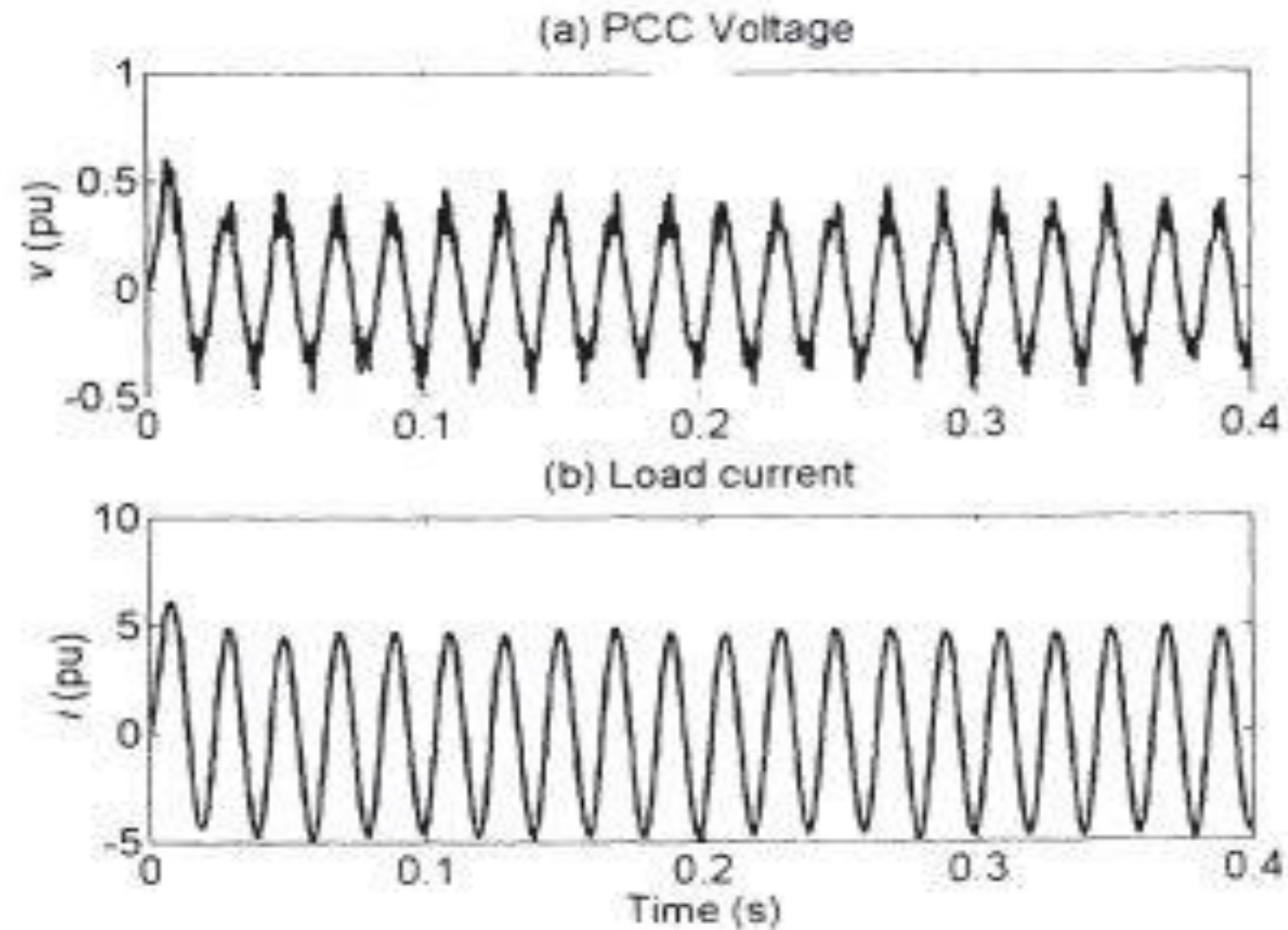



Summary





KEEP
LEARNING..
Thank u

SEE YOU IN NEXT CLASS