



# **SNS COLLEGE OF TECHNOLOGY**

**Coimbatore-35  
An Autonomous Institution**



Accredited by NBA – AICTE and Accredited by NAAC – UGC with 'A+' Grade  
Approved by AICTE, New Delhi & Affiliated to Anna University, Chennai

## **DEPARTMENT OF ELECTRONICS & COMMUNICATION ENGINEERING**

### **16EC303–VLSI DESIGN**

III YEAR/ V SEMESTER

UNIT 1 –MOS TRANSISTOR PRINCIPLE

TOPIC 8 –STICK DIAGRAM



# OUTLINE



- INTRODUCTION
- CMOS INVERTER
- MAPPING:STICK DIAGRAM -> CMOS TRANSISTOR CIRCUIT
- NMOS INVERTER-STICK DIAGRAM
- STATIC CMOS NAND GATE
- STATIC CMOS NOR GATE
- STATIC CMOS EXAMPLES-2 STYLES
- ACTIVITY
- EULER PATH
- YOUTUBE VIDEO
- ASSESSMENT



# STICK DIAGRAMS-INTRODUCTION



- Intermediate representation between circuit diagram and layout
- Symbolic design is "Sticks" layout.
- Metal-wire
- VDD-power supply
- POLY-Polysilicon (Gate)
- NDIFF-N diffusion(Source)
- PDIFF-P diffusion(Drain)
- VSS-Ground
- A,B-Input
- Y-Output

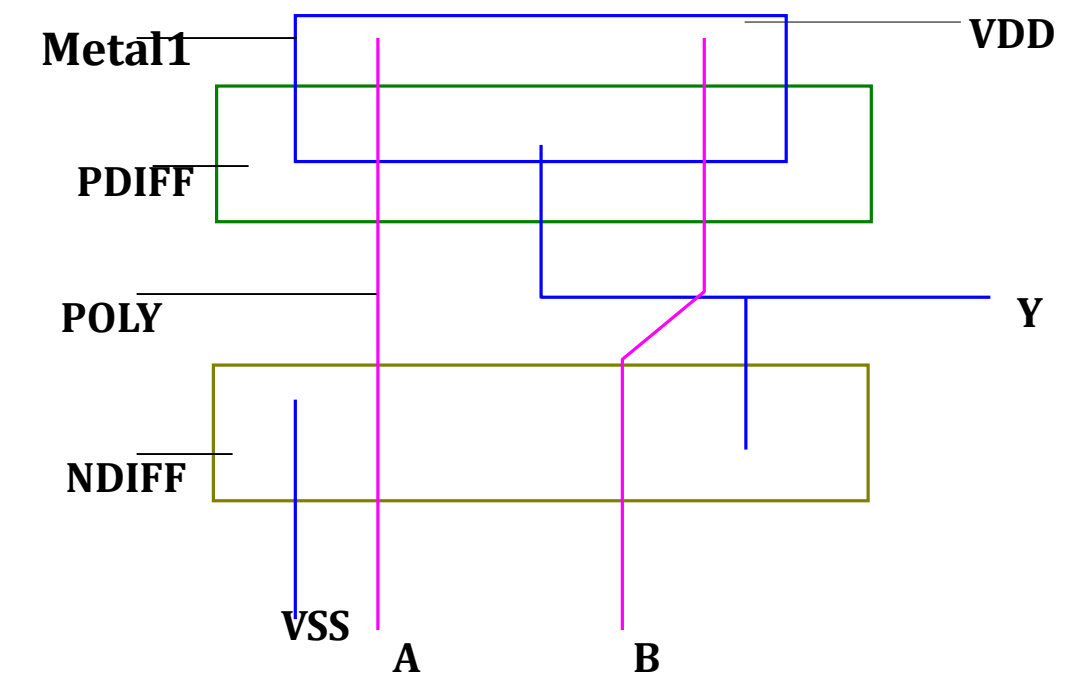
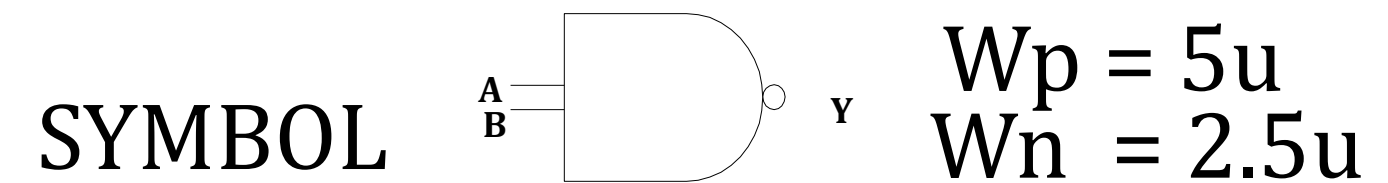

## Symbol and Stick Diagram of 2 inputs NAND gate



# CMOS INVERTER STICK DIAGRAM

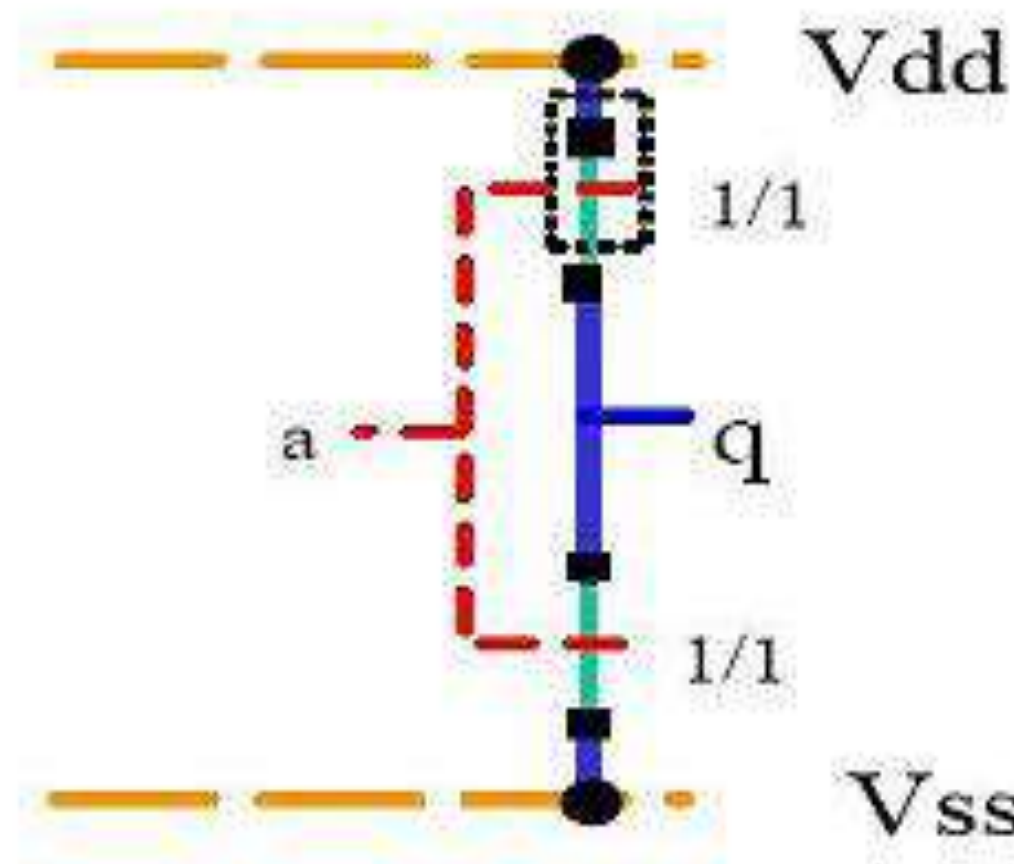
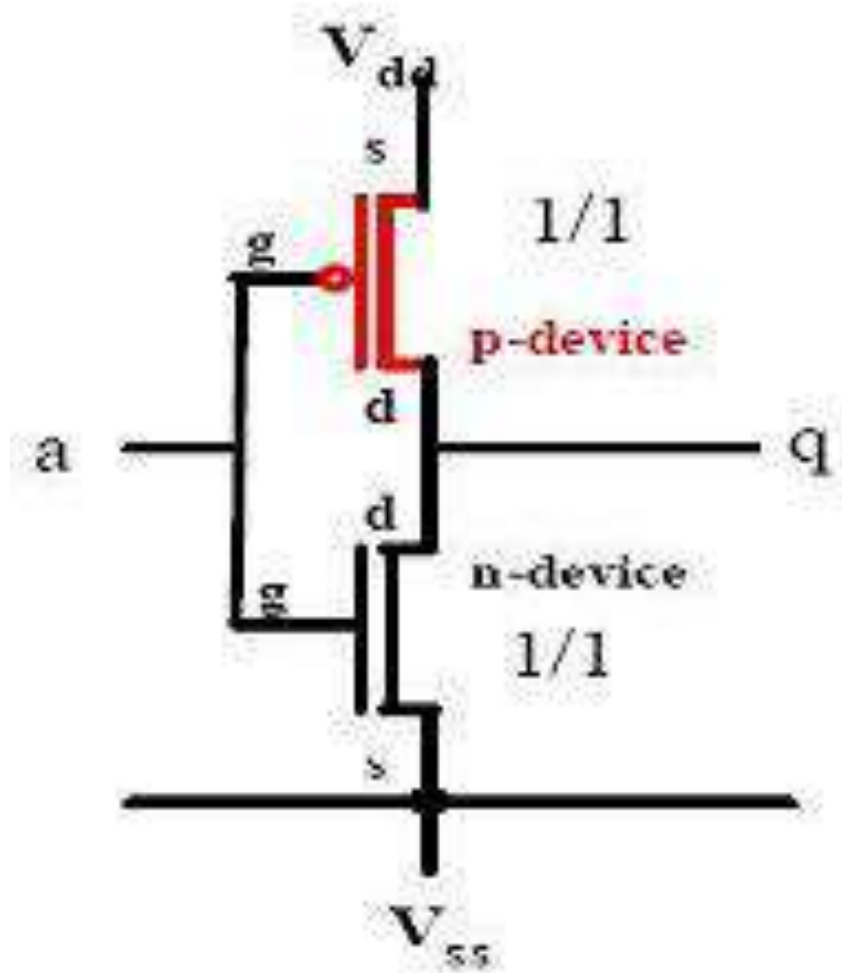

- Key
- Contact Cut
  - Metal1 to Metal2 Cut
  - Metal 1
  - Metal 2
  - Active
  - - - Poly
  - N well



# MAPPING:STICK DIAGRAM -> CMOS TRANSISTOR CIRCUIT

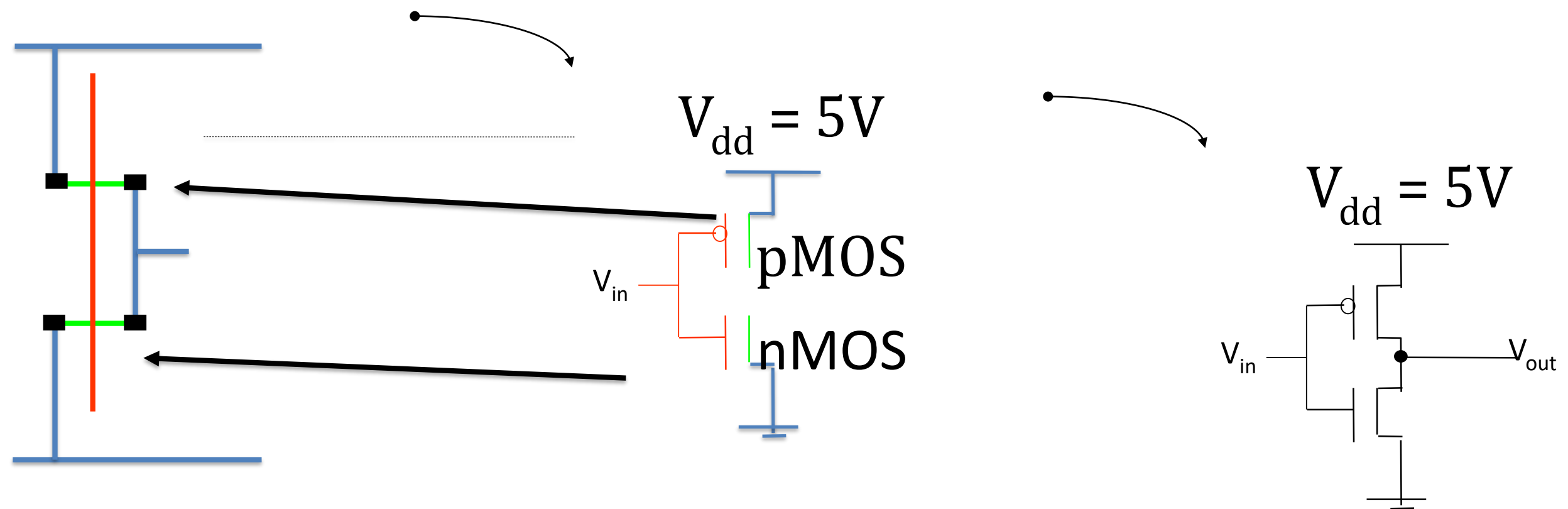



# NMOS INVERTER COLOURED STICK DIAGRAM



\* Note the depletion mode device

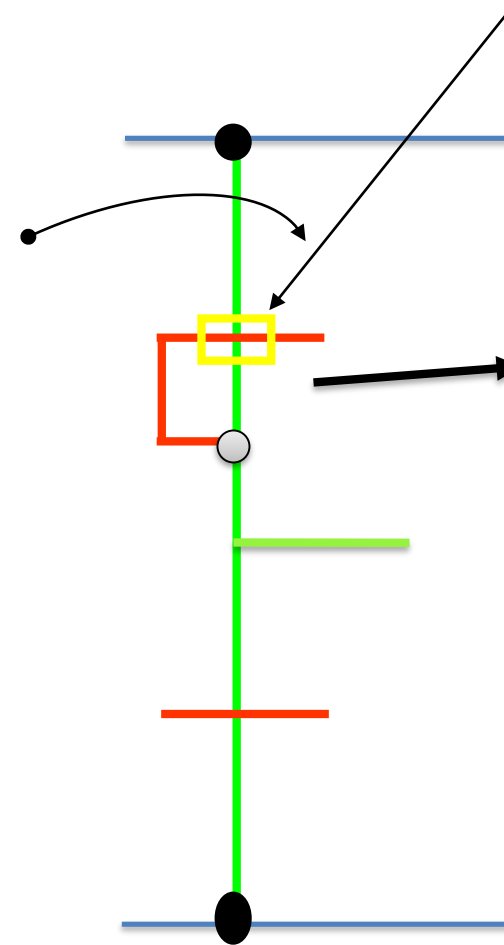
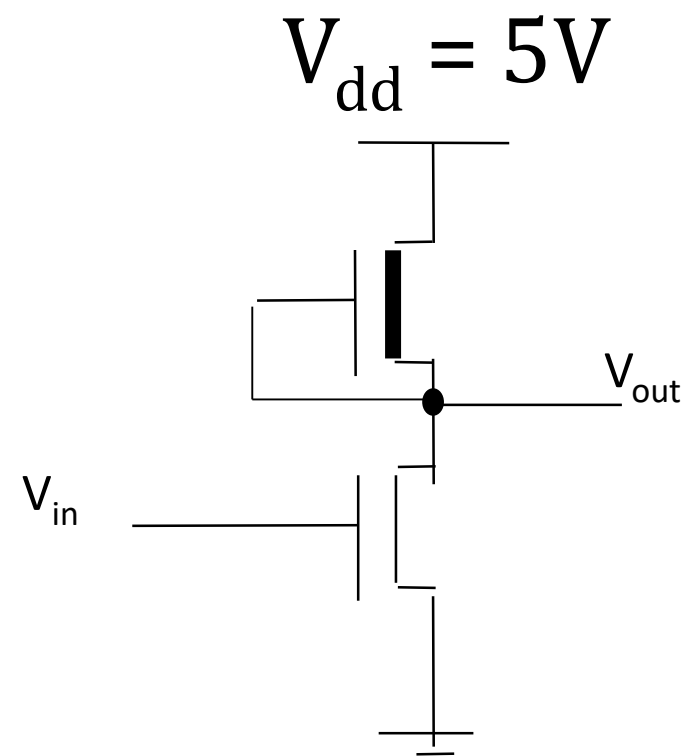



# STATIC CMOS NAND GATE

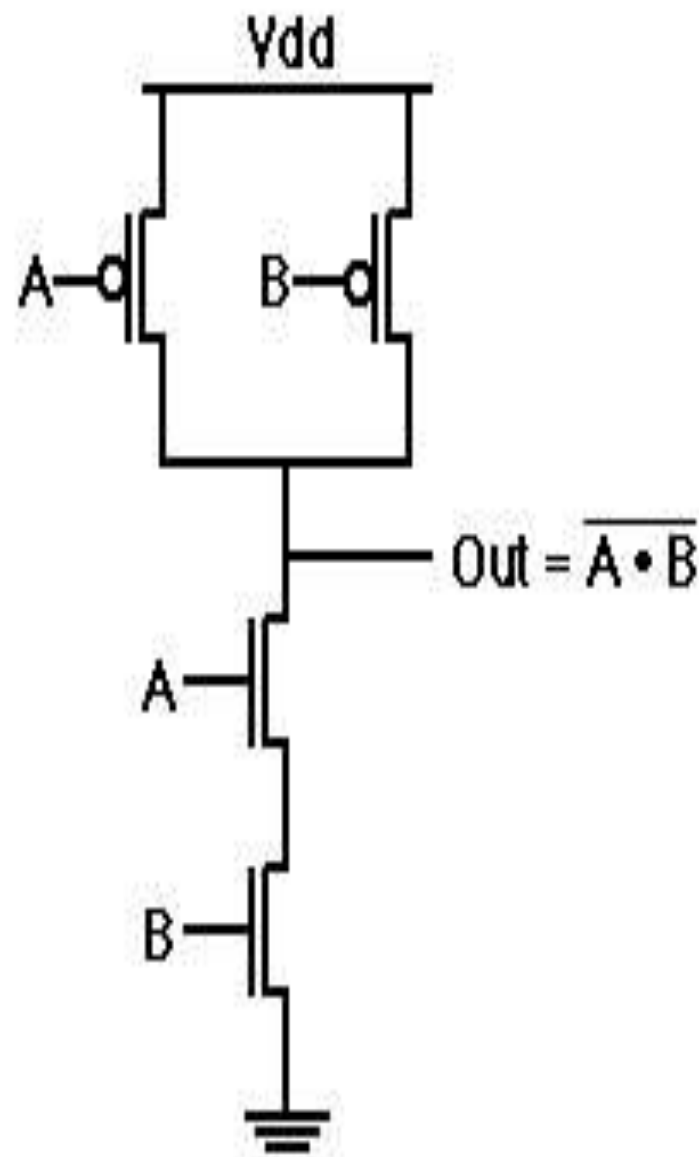

A	B	$\overline{A \cdot B}$
0	0	1
0	1	1
1	0	1
1	1	0

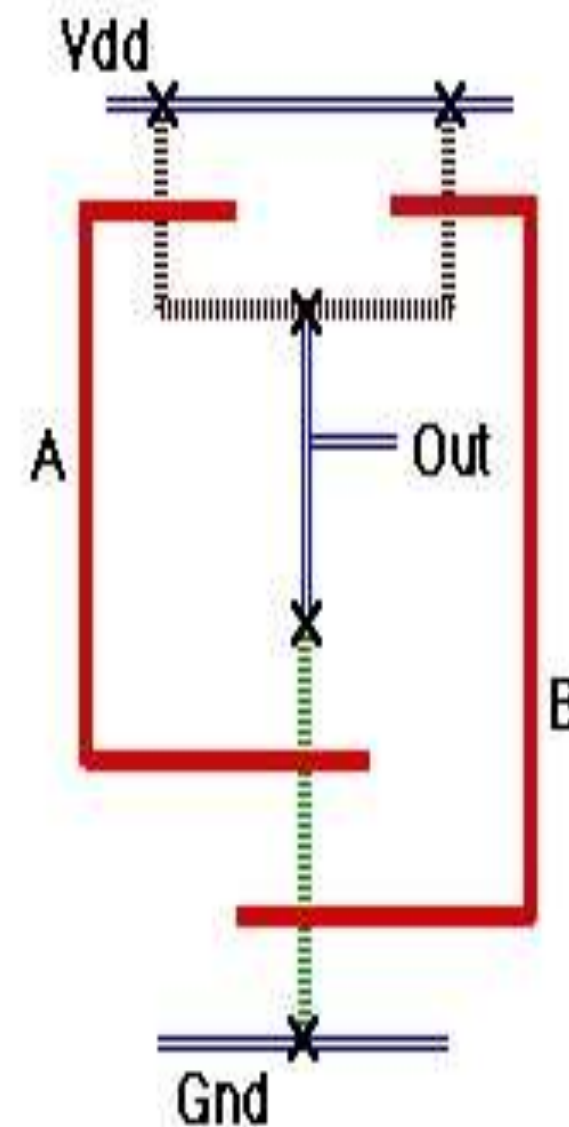

--Pull Down:  
Connect to  
ground If A=1  
**AND** B=1  
--Pull Up:  
Connect to VDD  
If A=0 **OR** B=0



# STATIC CMOS NOR GATE

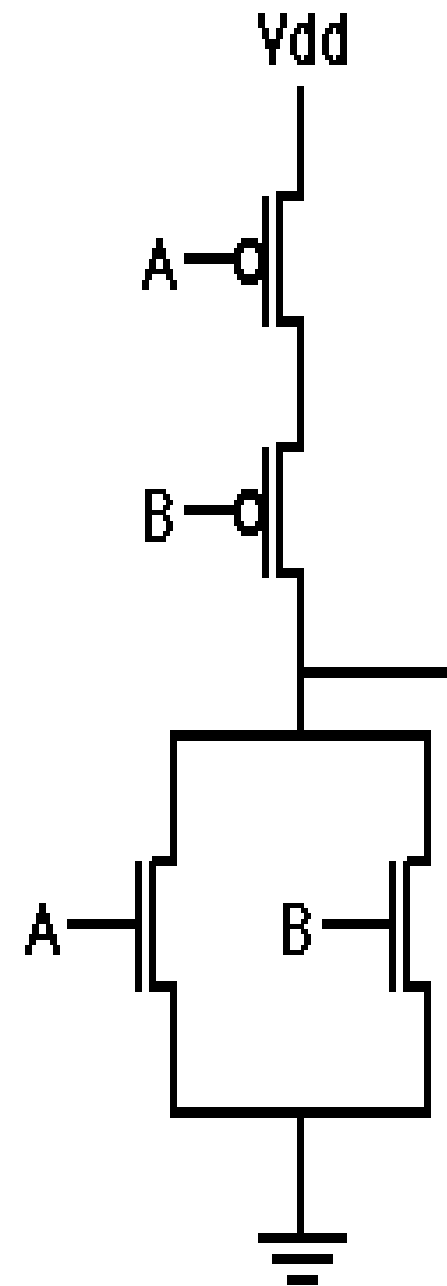

Out =  $\overline{A+B}$

A	B	$\overline{A+B}$
0	0	1
0	1	0
1	0	0
1	1	0

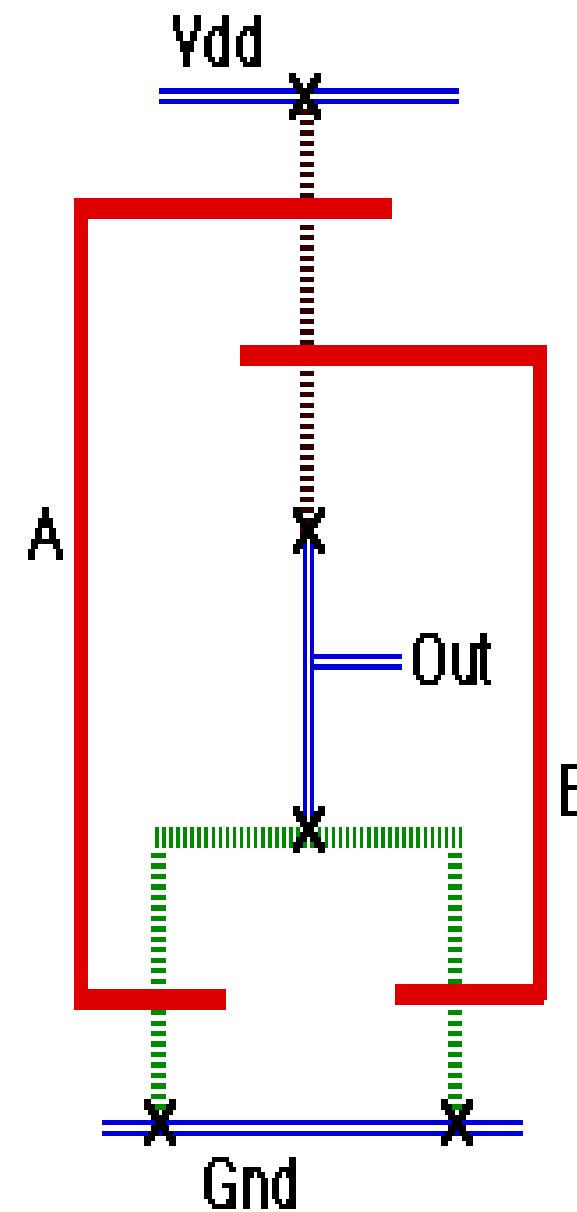

--Pull Down:  
Connect to  
ground If A=1 **OR**  
B=1  
--Pull Up:  
Connect to VDD  
If A=0 **AND** B=0





# STATIC CMOS DESIGN EXAMPLE STICK DIAGRAM

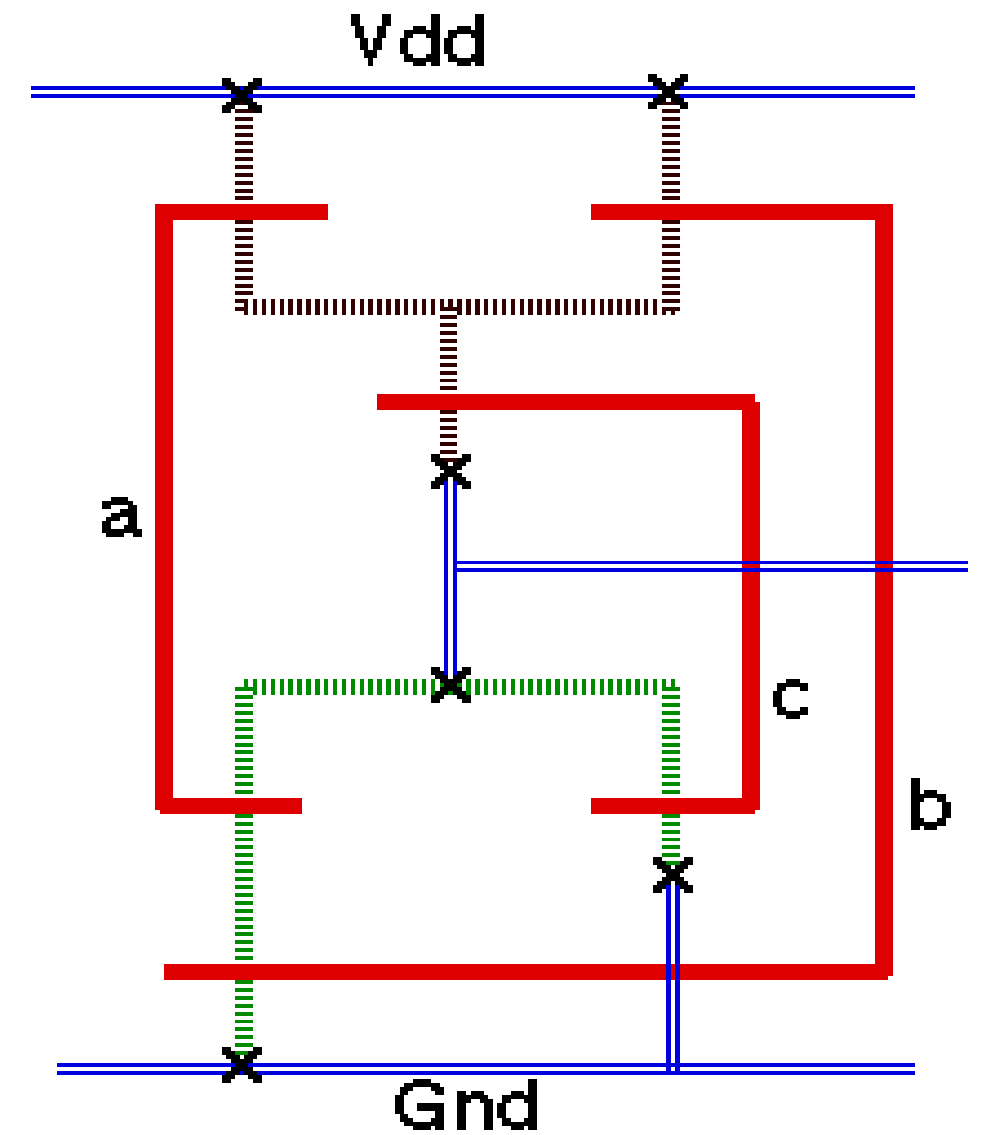
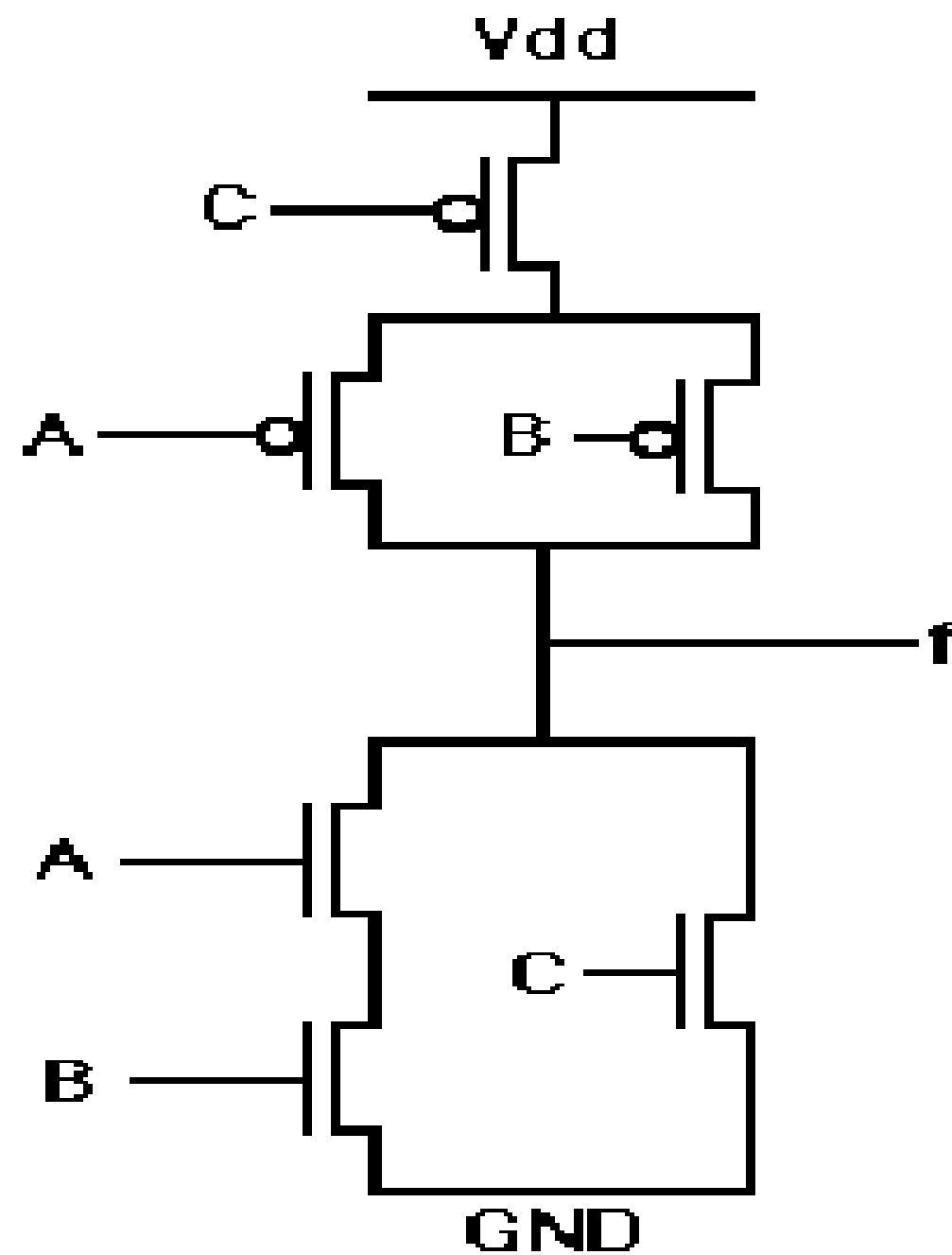

Example:  $f = \overline{a \cdot b} + c$



# STICK DIAGRAM 2 (DIFFERENT LAYOUT STYLE TO PREVIOUS BUT SAME FUNCTION BEING IMPLEMENTED)

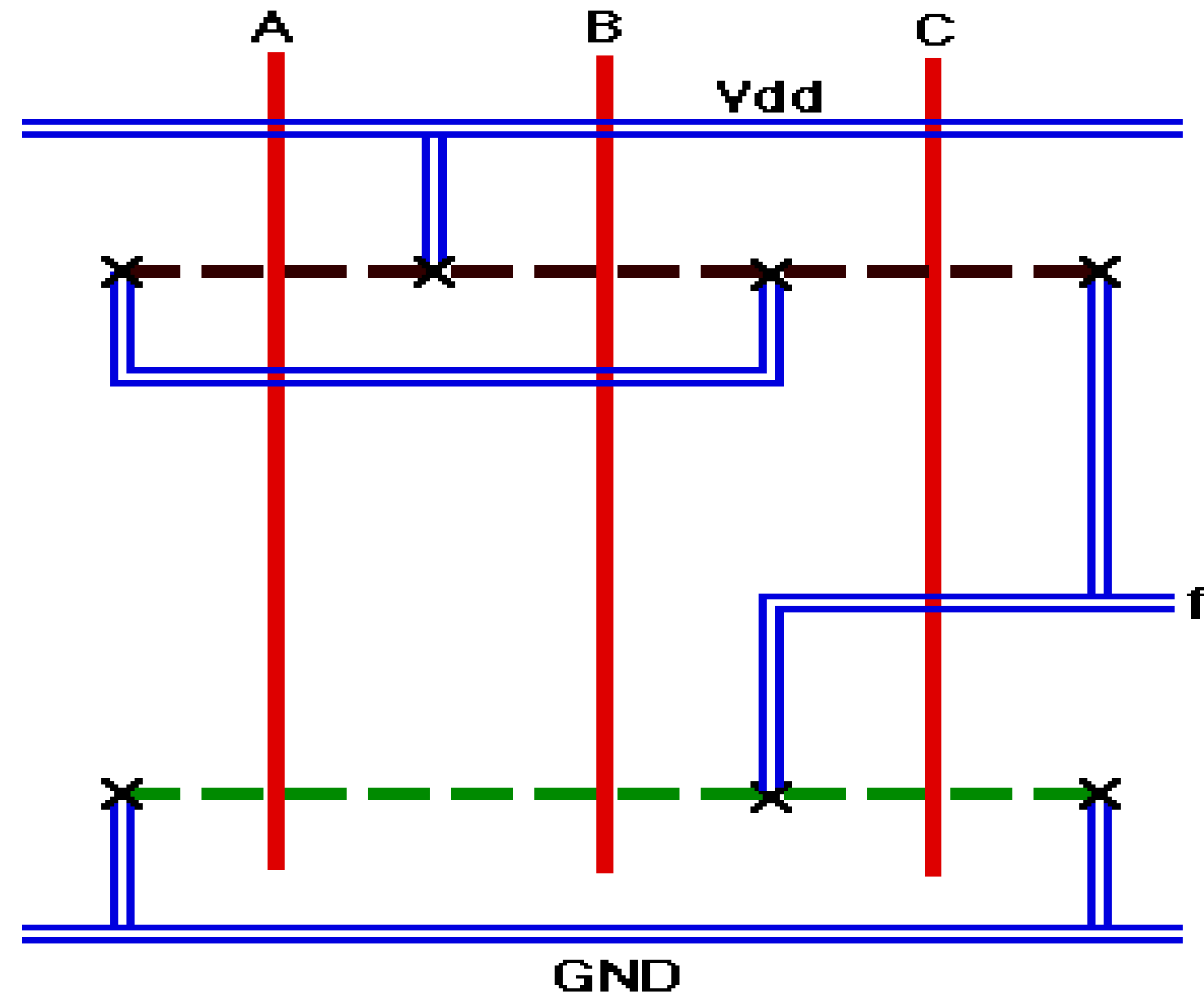
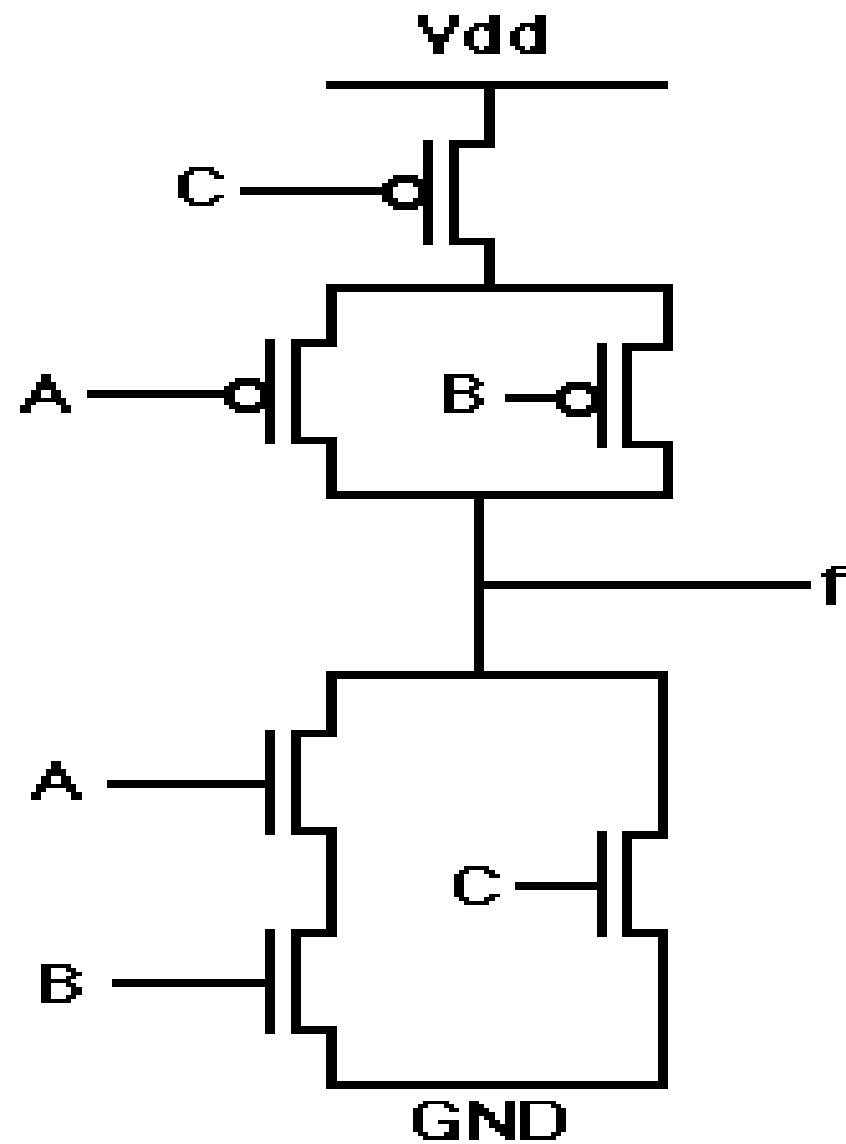

Example:  $f = \overline{(A \cdot B)} + C$



# COMPLEX LOGIC GATES LAYOUT



EX:  $F=AB+E+CD$

## Euler paths

Circuit to graph (convert)

1) Vertices are source/Drain connections

2) Edges are transistors

Find p and n Euler paths

$$F = (AB)+E+(CD)$$

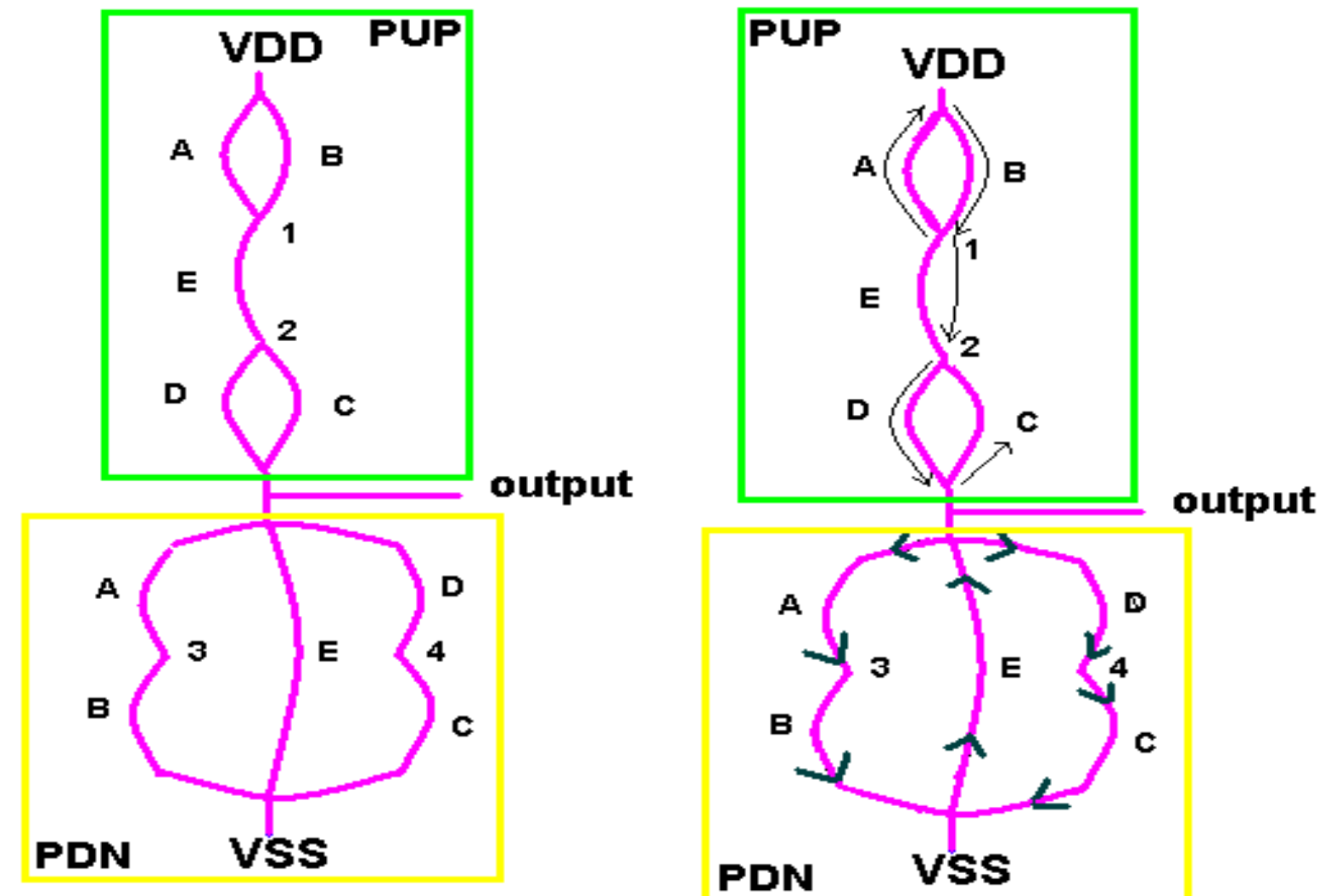

EULER PATH = {A,B,E,D,C}



## CLASS ROOM ACTIVITY



(A). 97 (B). 87 (C). 82 (D). 45



# EULER PATH



EULER PATH = {A,B,E,D,C}

- METAL 1
- POLY
- ACTIVE

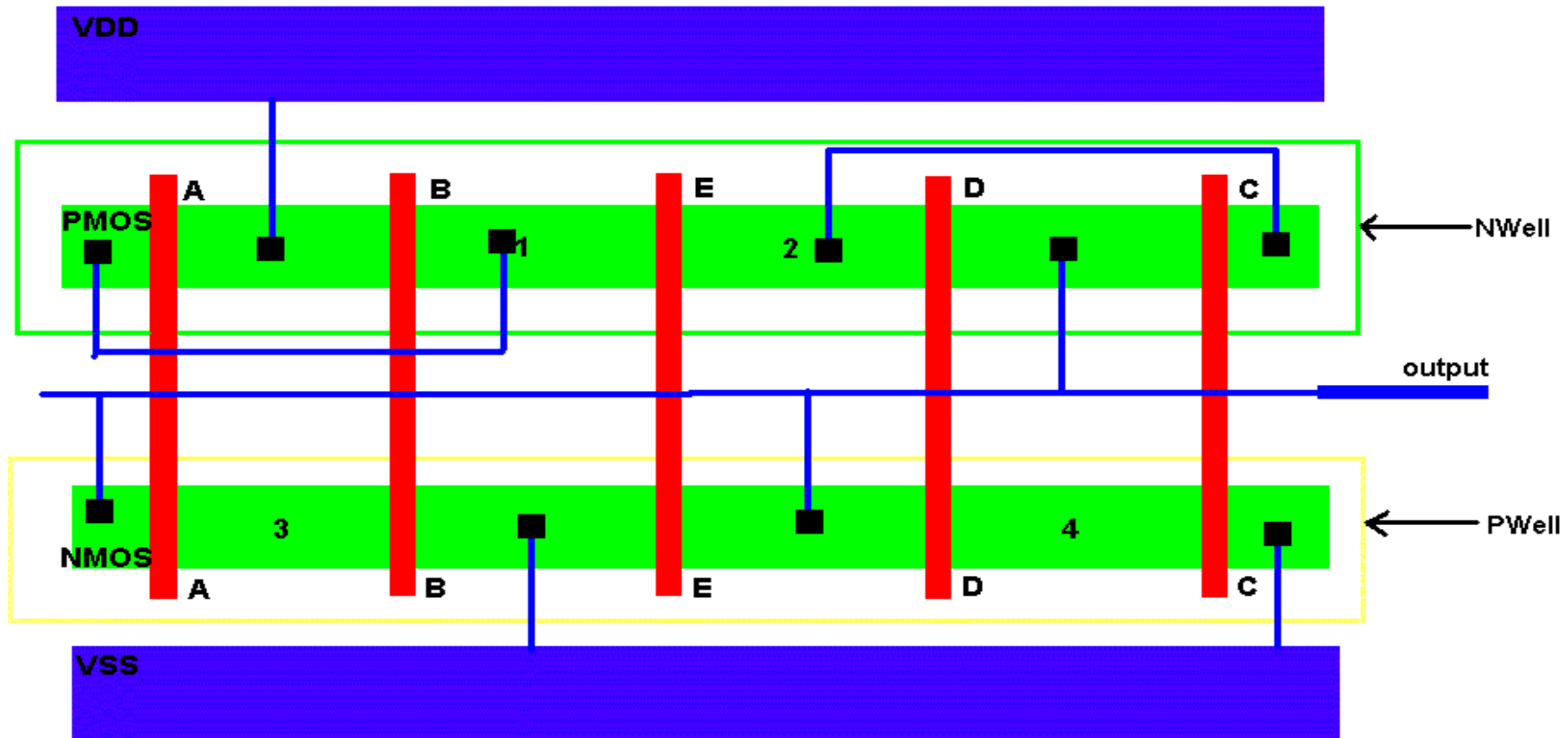



## PMOS & NMOS



- This notation indicates only the relative positioning of the various design components.
- The absolute coordinates of these elements are determined automatically by the editor using a compactor.
- The compactor translates the design rules into a set of constraints on the component positions, and solve a constrained optimization problem that attempts to minimize the area or cost function.

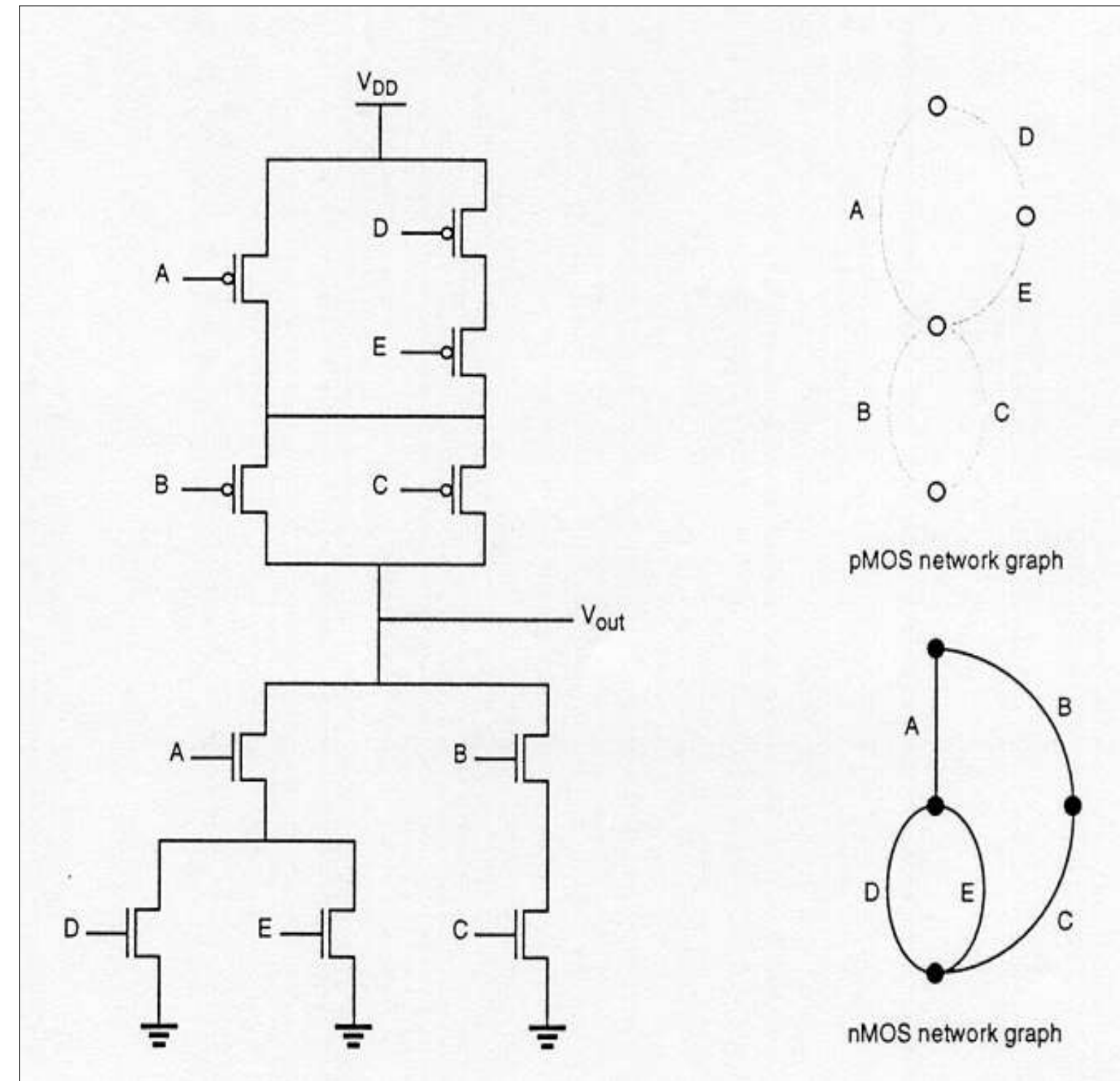



# EULER GRAPH-STICK DIAGRAM COMPARISON

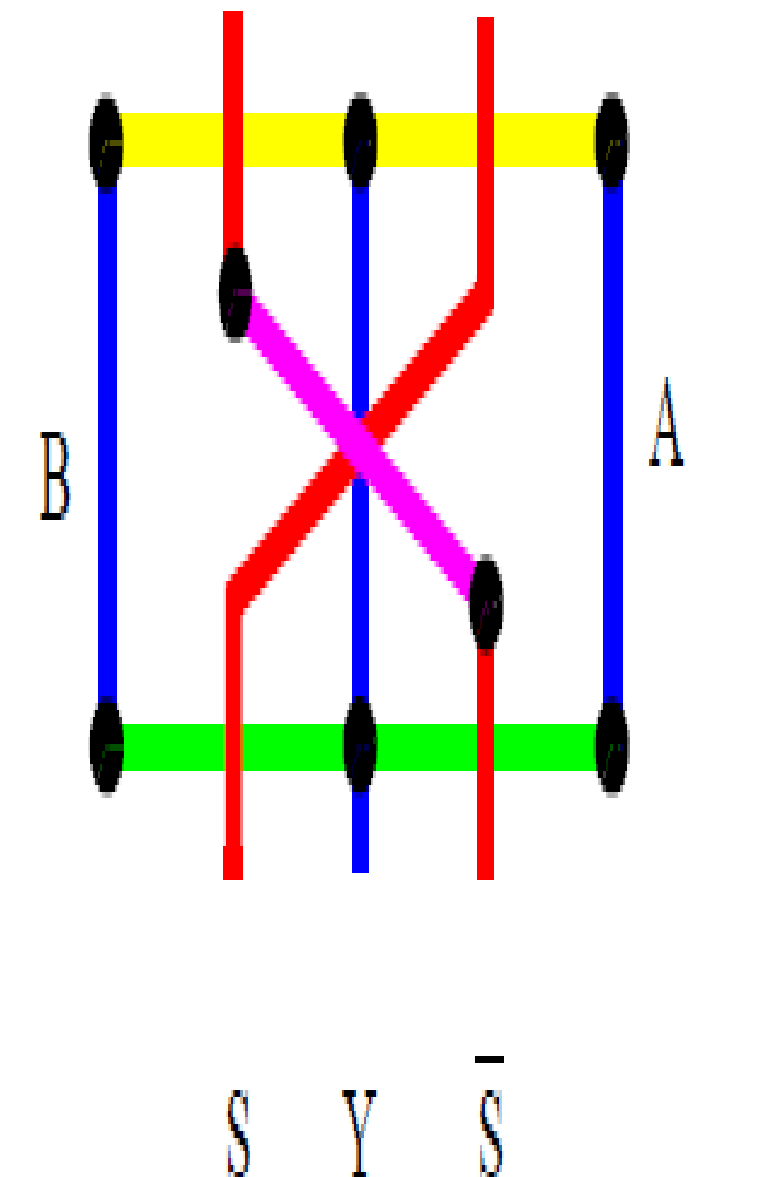
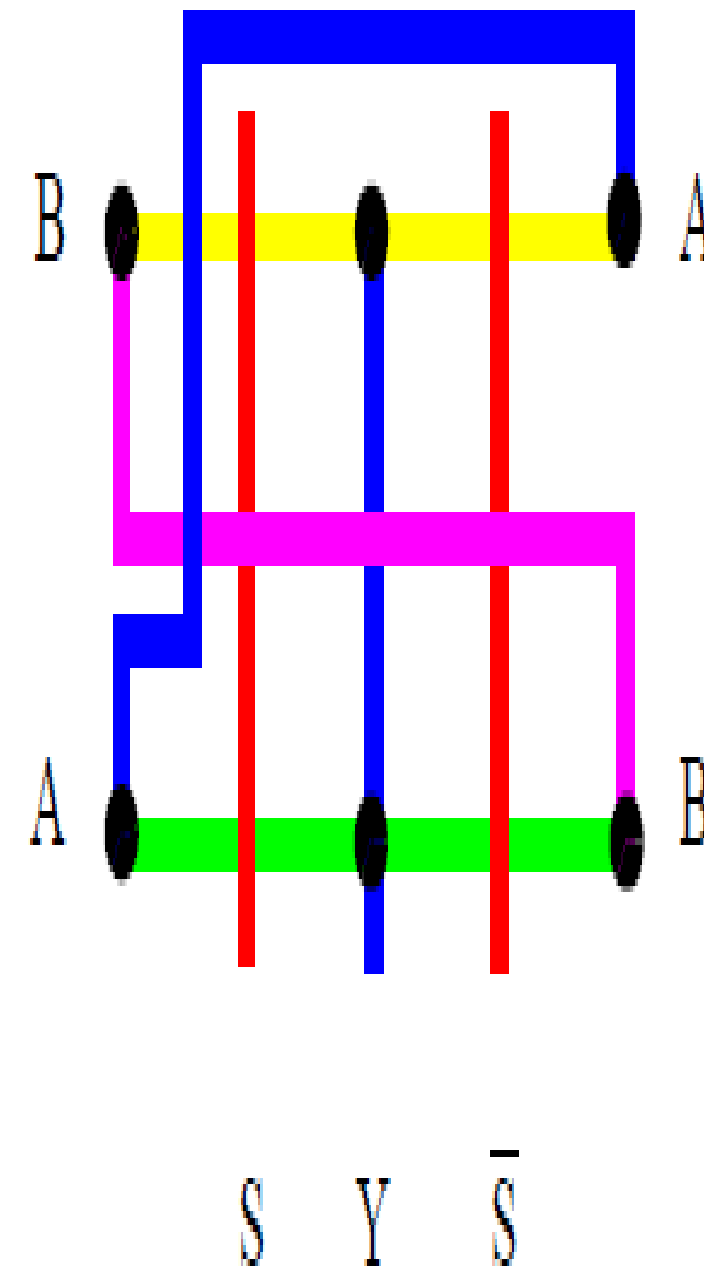
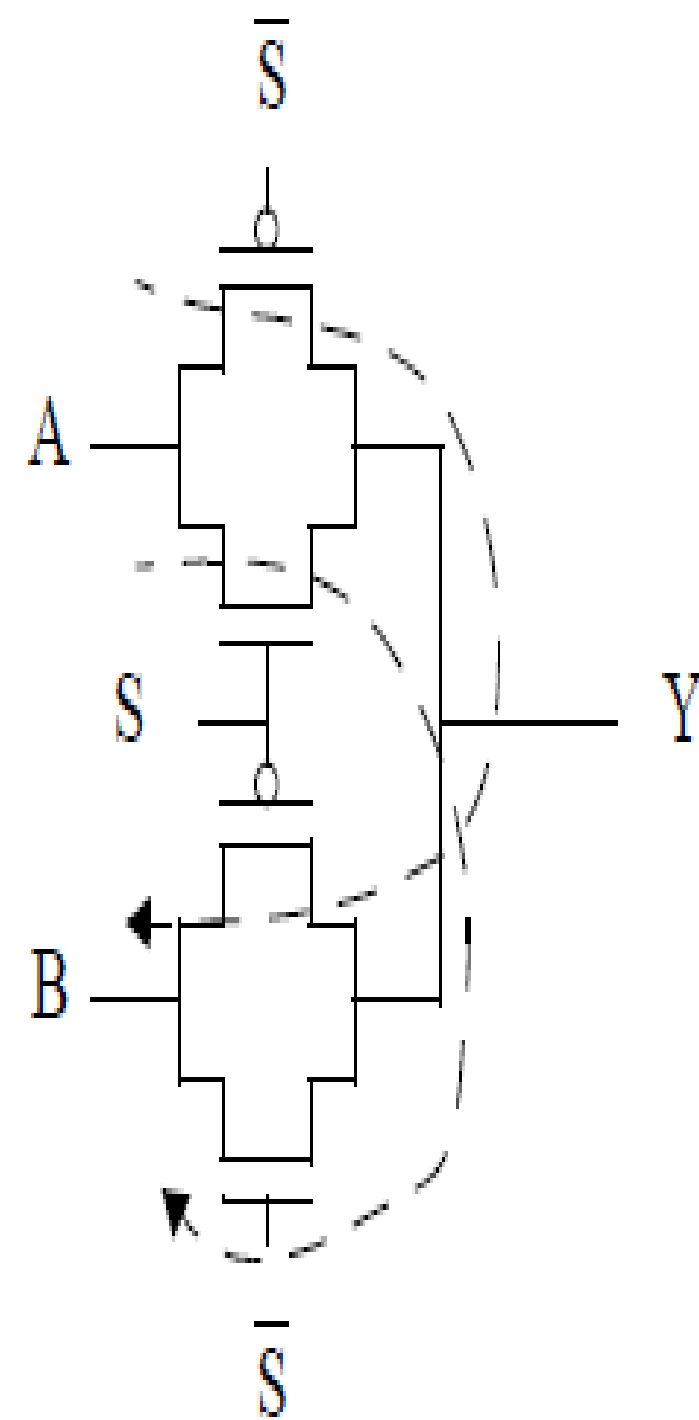
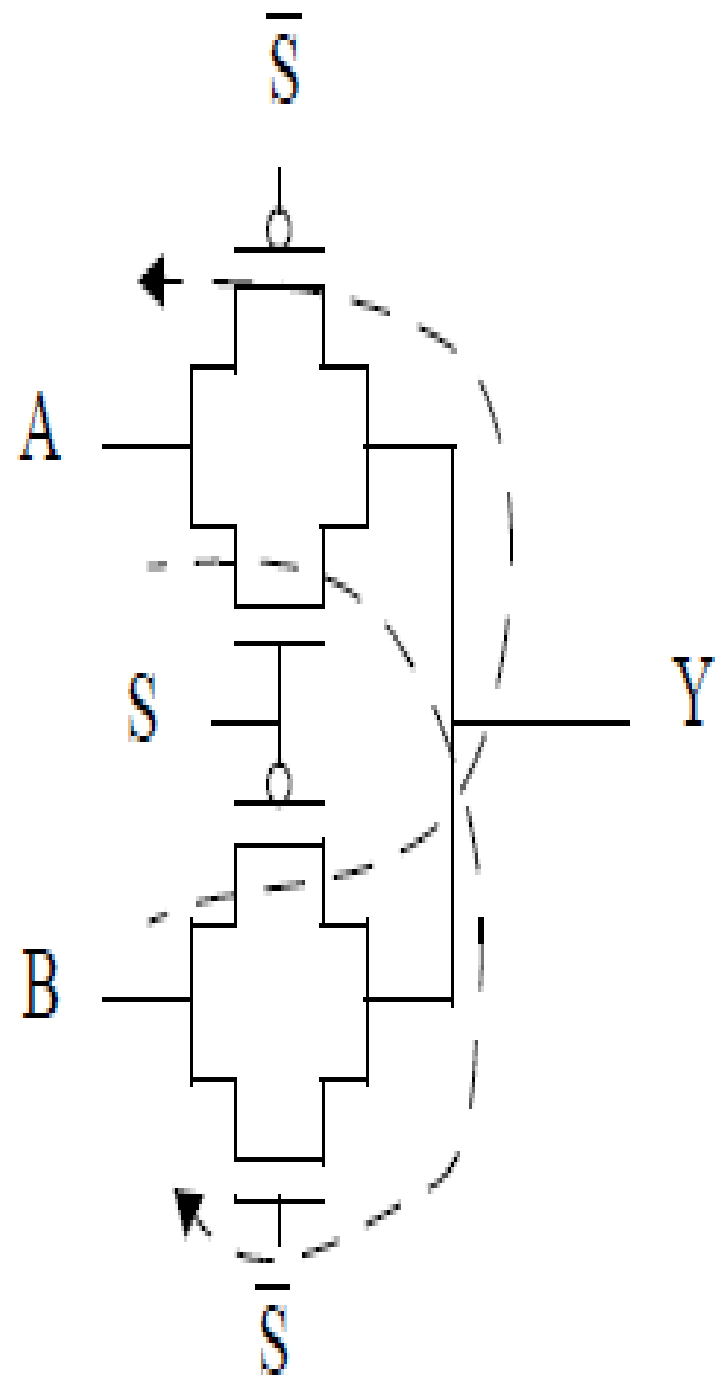



## YOUTUBE VIDEO LINK



STICK DIAGRAM - simplified (VLSI)

<https://www.youtube.com/watch?v=wqRGa5s0Umc&t=212s>





# ASSESSMENT- CMOS INVERTER COLOURED STICK DIAGRAM



1.DRAW THE CMOS  
INVERTER STICK  
DIAGRAM  
2.DRAW THE CMOS  
NAND GATE

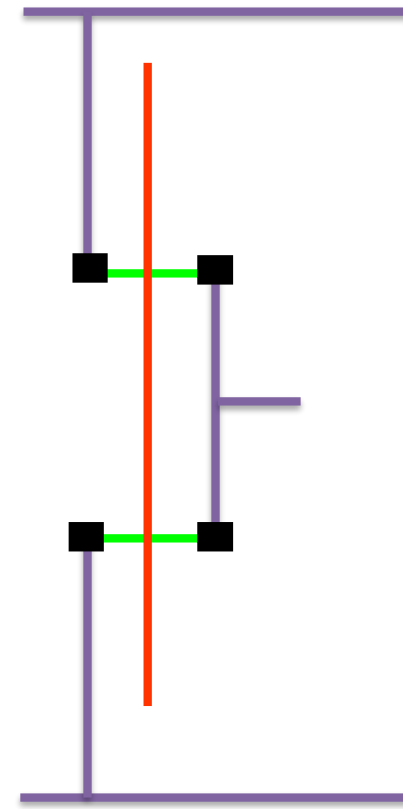

3.TELL ME THE  
COLOR CODING  
NAME ??????????



## ADVANTAGE & DISADVANTAGE



- **ADVANTAGE** : Designer does not have to worry about design rules, because the compactor ensures that the final layout is physically correct.
- **DISADVANTAGE** : The outcome of the compaction phase is often unpredictable. The resulting layout can be less dense than what is obtained with the manual approach. It does not show exact placement, transistor sizes, wire lengths, wire widths, tub boundaries.

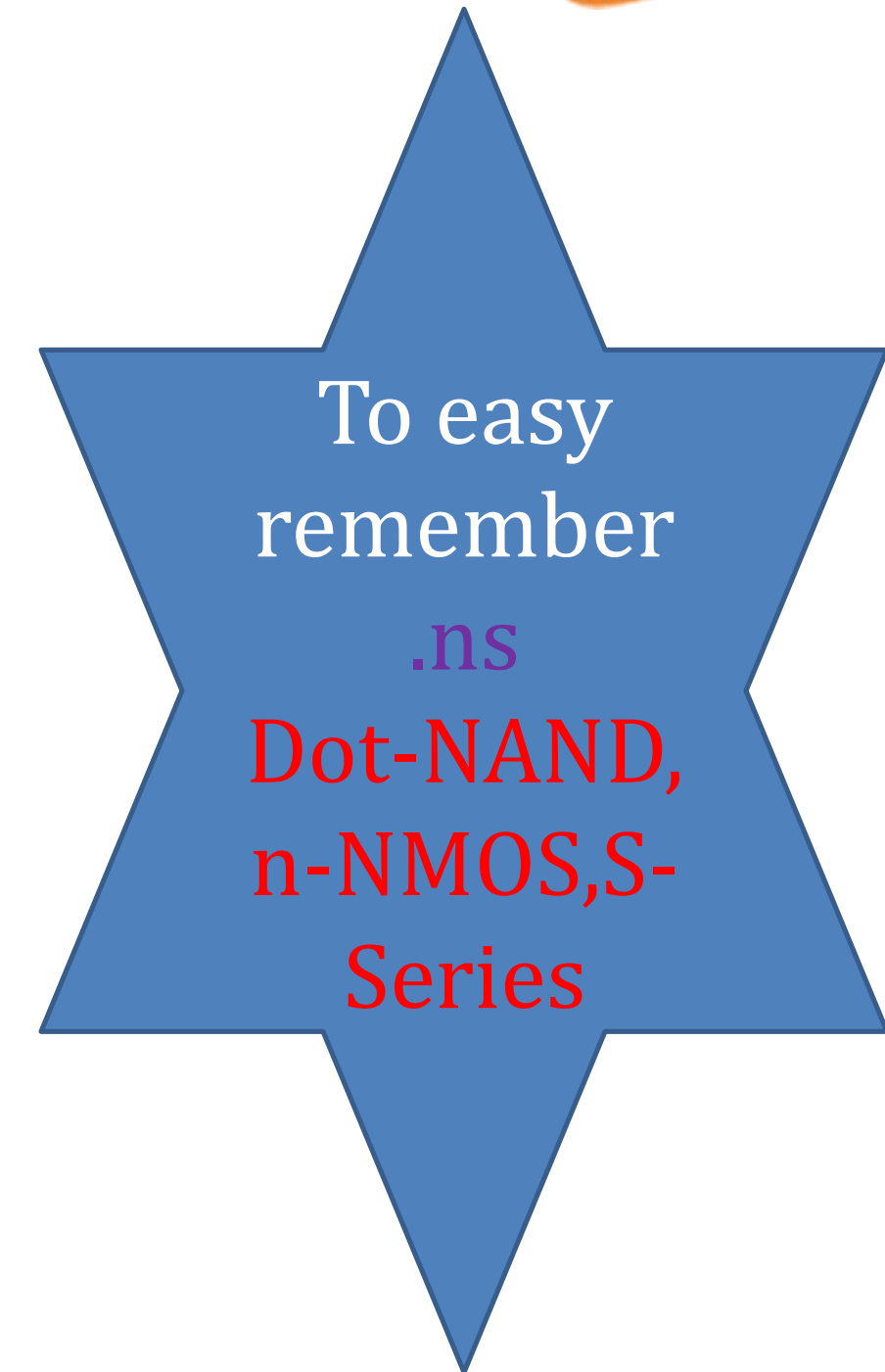



## SUMMARY & THANK YOU