

19EE502	POWER ELECTRONICS AND DRIVES	3	0	0	0	3
----------------	-------------------------------------	----------	----------	----------	----------	----------

COURSE OBJECTIVE	
1.	To acquire knowledge on the fundamentals of PE devices and drives.
2.	To understand the operation, topologies, characteristics and performance parameters of a DC converter (Controller rectifier & DC-DC converter).
3.	To learn the different modulation techniques of pulse width modulated inverters and study different configuration of AC-AC converter.
4.	To understand the operation and control of converter fed DC drive and chopper fed DC drive.
5.	To understand the operation and control of inverter fed AC drive.
<hr/>	
UNIT I	POWER SEMICONDUCTOR DEVICES 9
Structure, and operating characteristics of Power Diode, SCR, power BJT, MOSFET and IGBT, Switching characteristics, firing and protection circuits	
<hr/>	
UNIT II	DC CONVERTER 9
AC-DC Converters: 2 pulse, 3 pulse and 6 pulse converters – performance parameters – effect of source impedance	
DC to DC converters: step down chopper – step up chopper – control strategies – classification – switched mode regulators – buck, boost, buck boost converter – Introduction to SMPS	
<hr/>	
UNIT III	INVERTER 9
DC to AC converters: Single phase and three phase voltage source inverters (120° & 180° mode) – PWM techniques – Current source inverters – harmonic control – Introduction to UPS	
AC to AC Converters: Single phase AC voltage controllers, multistage control – single phase cyclo converters – Introduction to matrix converters	
<hr/>	
UNIT IV	INTRODUCTION TO DRIVES AND DC MOTOR DRIVES 9
Introduction to Drives: Fundamentals of Drive dynamics – Basic Elements- Modes of operation – Characteristics of electrical and mechanical loads-Classes of duty	
DC Motor drives: Single phase and three phase converter fed D.C motor drive. Chopper fed drives, input filter design. Braking and speed reversal of DC motor drives using choppers	
<hr/>	
UNIT V	AC MOTOR DRIVES 9
Induction Motor Drives: V/f control, rotor resistance control-slip power recovery schemes – voltage source and current source inverter fed induction motor drives	
Synchronous Motor drives: Synchronous motor control – analysis with electronic commutation – concept of self-control – stator current control and marginal angle control	
L: 45 T: 0 P:0 TOTAL:45 PERIODS	

TEXTBOOKS	
1.	Bimbra, P.S., “Power Electronics” Khanna Publishers, New Delhi, 7 th Revised Edition, 2022 (Unit I-III).
2.	Ion Boldea, Syed A. Nasar, “Electric Drives”, CRC Press, New Delhi 2016 (Unit IV-V).
REFERENCES	
1.	Ned Mohan, Tore. Undel, M., William. P. Robbins, “Power Electronics: Converters, Applications and Design” John Wiley & Sons, 3 rd Edition, 2007.
2.	Theodore Wildi, “Electrical Machines, Drives and Power Systems”, Pearson India, New Delhi, 6 th Edition, 2013.
3.	Krishnan, R., “Electric Motor Drives – Modeling, Analysis and Control”, Prentice-Hall of India, 2015.
4.	Bose, B.K., “Modern Power Electronics and A.C. Drives”, Academic Press, 2006
WEB RESOURCES	
1.	https://nptel.ac.in/courses/108101038
2.	https://nptel.ac.in/courses/108105066
3.	https://nptel.ac.in/courses/108104140

COURSE OUTCOMES	
At the end of the course, the student will be able to	
CO1: Demonstrate the operation and dynamic characteristics of power electronic devices.	
CO2 : Evaluate the performance characteristics of n-pulse converter and DC-DC converter.	
CO3 : Select suitable PWM technique with effective harmonic reduction.	
CO4 : Analyse the steady state behaviour of a DC drive.	
CO5 : Analyse the steady state behavior of a AC drive.	

UNIT – I

Power semiconductor devices and commutation circuits

Introduction to power electronics:

Power Electronics is a field which combines Power (electric power), Electronics and Control systems. Power engineering deals with the static and rotating power equipment for the generation, transmission and distribution of electric power. Electronics deals with the study of solid state semiconductor power devices and circuits for Power conversion to meet the desired control objectives (to control the output voltage and output power). Power electronics may be defined as the subject of applications of solid state power semiconductor devices (Thyristors) for the control and conversion of electric power. Power electronics deals with the study and design of Thyristorised power controllers for variety of application like Heat control, Light/Illumination control, Motor control - AC/DC motor drives used in industries, High voltage power supplies, Vehicle propulsion systems, High voltage direct current (HVDC) transmission.

Power Electronics refers to the process of controlling the flow of current and voltage and converting it to a form that is suitable for user loads. The most desirable power electronic system is one whose efficiency and reliability is 100%.

Take a look at the following block diagram. It shows the components of a Power Electronic system and how they are interlinked.

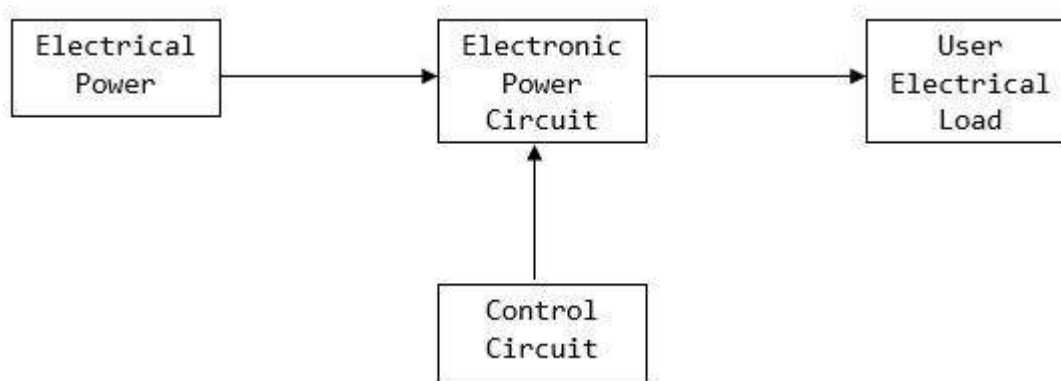

Figure: 1.1. Block diagram of DC power supply

A power electronic system converts electrical energy from one form to another and ensures the following is achieved –

- Maximum efficiency
- Maximum reliability
- Maximum availability
- Minimum cost
- Least weight
- Small size

Applications of Power Electronics are classified into two types – Static Applications and Drive Applications.

Static Applications

This utilizes moving and/or rotating mechanical parts such as welding, heating, cooling, and electroplating and DC power.

DC Power Supply

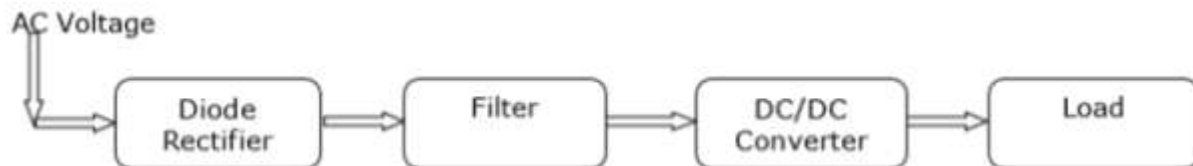

Figure: 1.2. Block diagram of DC power supply

Drive Applications

Drive applications have rotating parts such as motors. Examples include compressors, pumps, conveyer belts and air conditioning systems.

Air Conditioning System

Power electronics is extensively used in air conditioners to control elements such as compressors. A schematic diagram that shows how power electronics is used in air conditioners is shown below.

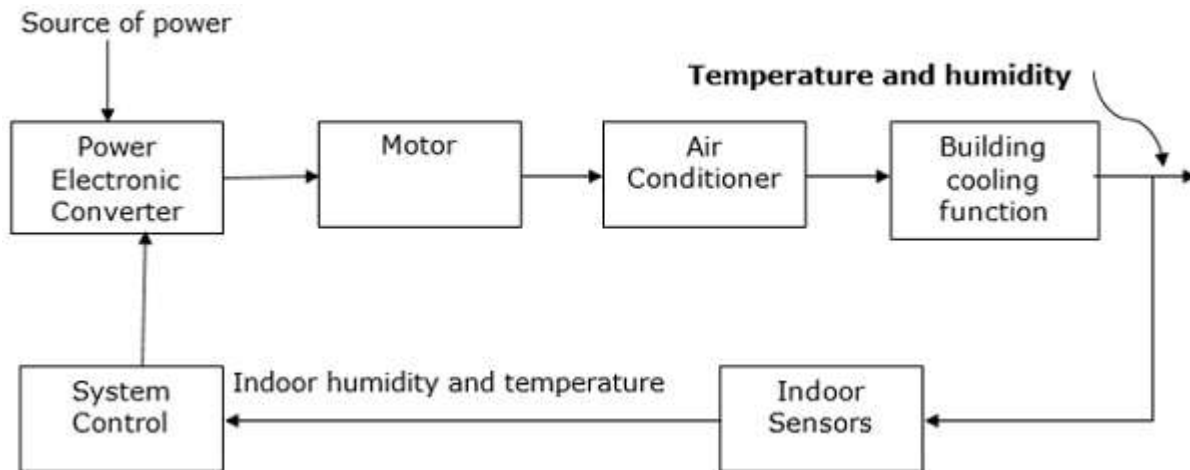

Figure: 1.3. Block diagram of Air Conditioning System

Power electronic applications

Commercial applications Heating Systems Ventilating, Air Conditioners, Central Refrigeration, Lighting, Computers and Office equipments, Uninterruptible Power Supplies (UPS), Elevators, and Emergency Lamps

Domestic applications Cooking Equipments, Lighting, Heating, Air Conditioners, Refrigerators & Freezers, Personal Computers, Entertainment Equipments, UPS

Industrial applications Pumps, compressors, blowers and fans Machine tools, arc furnaces, induction furnaces, lighting control circuits, industrial lasers, induction heating, welding equipments

Aerospace applications Space shuttle power supply systems, satellite power systems, aircraft power systems.

Telecommunications Battery chargers, power supplies (DC and UPS), mobile cell phone battery chargers

Transportation Traction control of electric vehicles, battery chargers for electric vehicles, electric locomotives, street cars, trolley buses, automobile electronics including engine controls

Utility systems High voltage DC transmission (HVDC), static VAR compensation (SVC), Alternative energy sources (wind, photovoltaic), fuel cells, energy storage systems, induced draft fans and boiler feed water pumps

Types of power electronic converters

1. Rectifiers (AC to DC converters): These converters convert constant ac voltage to variable dc output voltage.
2. Choppers (DC to DC converters): Dc chopper converts fixed dc voltage to a controllable dc output voltage.
3. Inverters (DC to AC converters): An inverter converts fixed dc voltage to a variable ac output voltage.
4. AC voltage controllers: These converters converts fixed ac voltage to a variable ac output voltage at same frequency.
5. Cycloconverters: These circuits convert input power at one frequency to output power at a different frequency through one stage conversion.

Power semiconductor devices

- i. Power Diodes.
- ii. Power transistors (BJT's).
- iii. Power MOSFETS.
- iv. IGBT's.
- v. Thyristors

Thyristors are a family of p-n-p-n structured power semiconductor switching devices

Power diodes

Power diodes are made of silicon p-n junction with two terminals, anode and cathode. P-N junction is formed by alloying, diffusion and epitaxial growth. Modern techniques in diffusion and epitaxial processes permit desired device characteristics. The diodes have the following advantages High mechanical and thermal reliability High peak inverse voltage Low reverse current Low forward voltage drop High efficiency Compactness.

Power transistors

Power transistors are devices that have controlled turn-on and turn-off characteristics. These devices are used a switching devices and are operated in the saturation region resulting in low on-state voltage drop. They are turned on when a current signal is given to base or control terminal. The transistor remains on so long as the control signal is present. The switching speed of modern transistors is much higher than that of thyristors and is used extensively in dc-dc and dc-ac converters. However their

voltage and current ratings are lower than those of thyristors and are therefore used in low to medium power applications. Power transistors are classified as follows

- o Bipolar junction transistors(BJTs)
- o Metal-oxide semiconductor field-effect transistors(MOSFETs)
- o Static Induction transistors(SITs)
- o Insulated-gate bipolar transistors(IGBTs)

Advantages of BJT'S

- i. BJT's have high switching frequencies since their turn-on and turn-off time are low.
- ii. The turn-on losses of a BJT are small.
- iii. BJT has controlled turn-on and turn-off characteristics since base drive control is possible.
- iv. BJT does not require commutation circuits

Demerits of BJT

- i. Drive circuit of BJT is complex.
- ii. It has the problem of charge storage which sets a limit on switching frequencies.
- iii. It cannot be used in parallel operation due to problems of negative temperature coefficient.

Thyristors – Silicon Controlled Rectifiers (SCR's)

A silicon controlled rectifier or semiconductor-controlled rectifier is a four-layer solidstate current-controlling device. The name "silicon controlled rectifier" is General Electric's trade name for a type of thyristor.

SCRs are mainly used in electronic devices that require control of high voltage and power. This makes them applicable in medium and high AC power operations such as motor control function.

An SCR conducts when a gate pulse is applied to it, just like a diode. It has four layers of semiconductors that form two structures namely; NPNP or PNP. In addition, it has three junctions labeled as J1, J2 and J3 and three terminals(anode, cathode and a gate). An SCR is diagrammatically represented as shown below.

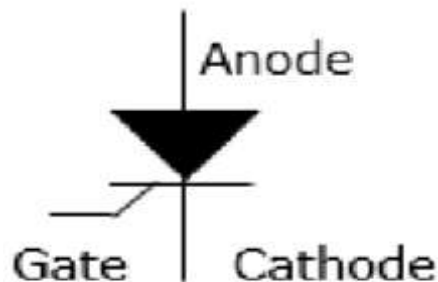

Figure: 1.4. Symbol of thyristor

The anode connects to the P-type, cathode to the N-type and the gate to the P-type as shown below.

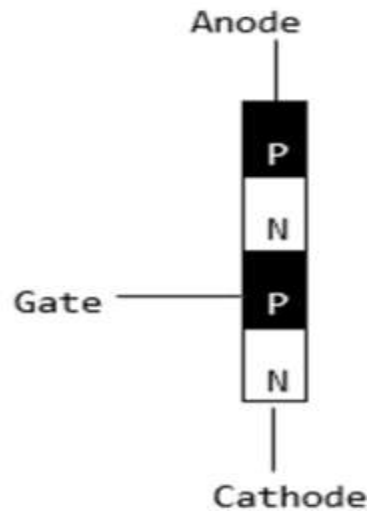

Figure: 1.5. Structure of thyristor

In an SCR, the intrinsic semiconductor is silicon to which the required dopants are infused. However, doping a PNPJ junction is dependent on the SCR application.

Modes of Operation in SCR

- OFF state (forward blocking mode) – Here the anode is assigned a positive voltage, the gate is assigned a zero voltage (disconnected) and the cathode is assigned a negative voltage. As a result, Junctions J1 and J3 are in forward bias while J2 is in reverse bias. J2 reaches its breakdown avalanche value and starts to conduct. Below this value, the resistance of J1 is significantly high and is thus said to be in the off state.
- ON state (conducting mode) – An SCR is brought to this state either by increasing the potential difference between the anode and cathode above the avalanche voltage or by applying a positive signal at the gate. Immediately the SCR starts to conduct, gate voltage is no longer needed to maintain the ON state and is, therefore, switched off by –
 - Decreasing the current flow through it to the lowest value called holding current
 - Using a transistor placed across the junction.
- Reverse blocking – This compensates the drop in forward voltage. This is due to the fact that a low doped region in P1 is needed. It is important to note that the voltage ratings of forward and reverse blocking are equal.

Characteristics of Thyristor

A thyristor is a four layer 3 junction p-n-p-n semiconductor device consisting of at least three p-n junctions, functioning as an electrical switch for high power operations. It has three basic terminals, namely the anode, cathode and the gate mounted on the semiconductor layers of the device. The symbolic diagram and the basic circuit diagram for determining the characteristics of thyristor is shown in the figure below,

V-I Characteristics of a Thyristor

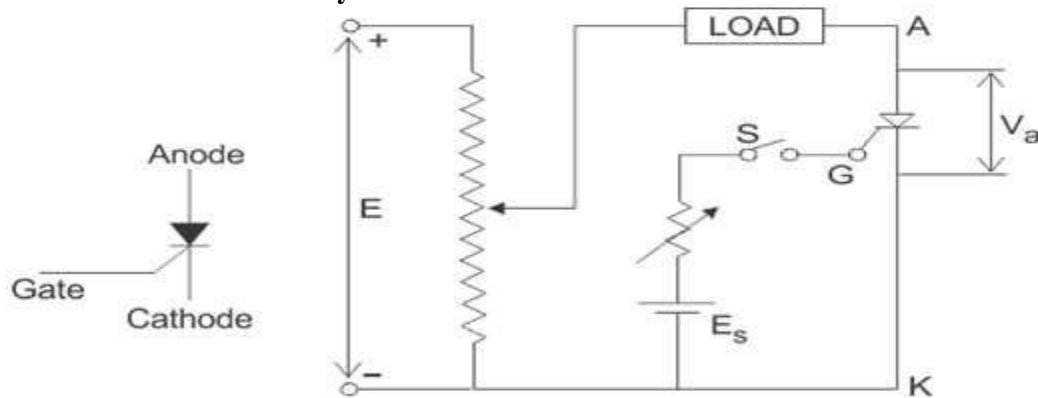

Figure: 1.6. Circuit diagram for characteristics of SCR

From the circuit diagram above we can see the anode and cathode are connected to the supply voltage through the load. Another secondary supply E_s is applied between the gate and the cathode terminal which supplies for the positive gate current when the switch S is closed. On giving the supply we get the required V-I characteristics of a thyristor show in the figure below for anode to cathode voltage V_a and anode current I_a as we can see from the circuit diagram. A detailed study of the characteristics reveal that the thyristor has three basic modes of operation, namely the reverse blocking mode, forward blocking (off-state) mode and forward conduction (on-state) mode. Which are discussed in great details below, to understand the overall characteristics of a thyristor.

Reverse Blocking Mode of Thyristor

Initially for the reverse blocking mode of the thyristor, the cathode is made positive with respect to anode by supplying voltage E and the gate to cathode supply voltage E_s is detached initially by keeping switch S open. For understanding this mode we should look into the fourth quadrant where the thyristor is reverse biased.

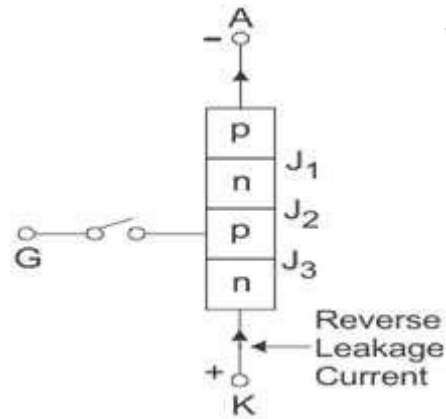

Figure: 1.7. Reverse blocking mode of SCR

Here Junctions J_1 and J_3 are reverse biased whereas the junction J_2 is forward biased. The behavior of the thyristor here is similar to that of two diodes are connected in series with reverse voltage applied across them. As a result only a small leakage current of the order of a few μAmps flows. This is the reverse blocking mode or the off-state, of the thyristor. If the reverse voltage is now increased, then at a particular voltage, known as the critical breakdown voltage V_{BR} , an avalanche occurs at J_1 and J_3 and the reverse current increases rapidly. A large current associated with V_{BR} gives rise to more losses in the SCR, which results in heating. This may lead to thyristor damage as the junction temperature may exceed its permissible temperature rise. It should, therefore, be ensured that maximum working reverse voltage across a thyristor does not exceed V_{BR} . When reverse voltage applied across a thyristor is less than V_{BR} , the device offers very high impedance in the reverse direction. The SCR in the reverse blocking mode may therefore be treated as open circuit.

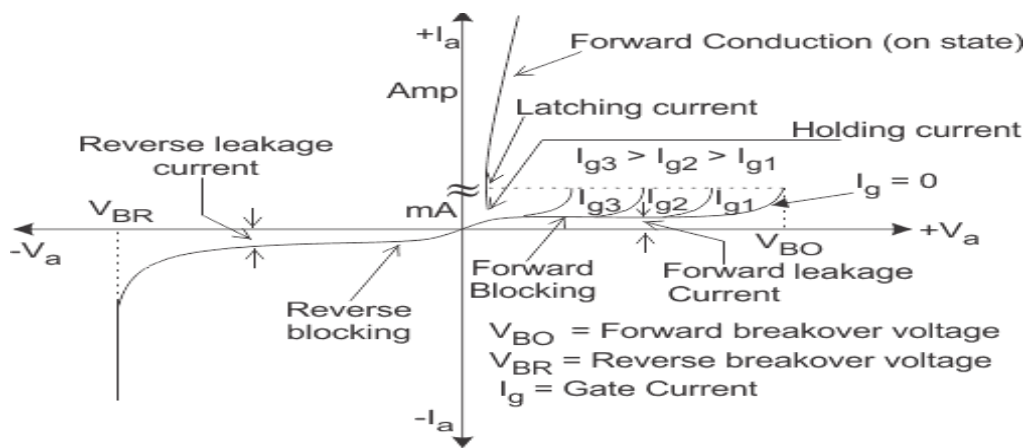

Figure: 1.8. V- I characteristics of SCR

Forward Blocking Mode Now considering the anode is positive with respect to the cathode, with gate kept in open condition. The thyristor is now said to be forward biased as shown the figure below.

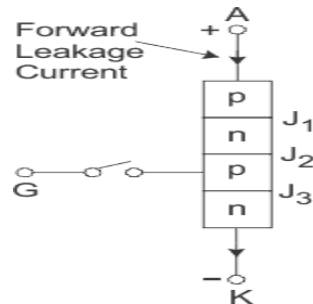

Figure: 1.9. Forward connection of SCR

As we can see the junctions J_1 and J_3 are now forward biased but junction J_2 goes into reverse biased condition. In this particular mode, a small current, called forward leakage current is allowed to flow initially as shown in the diagram for characteristics of thyristor. Now, if we keep on increasing the forward biased anode to cathode voltage.

In this particular mode, the thyristor conducts currents from anode to cathode with a very small voltage drop across it. A thyristor is brought from forward blocking mode to forward conduction mode by turning it on by exceeding the forward break over voltage or by applying a gate pulse between gate and cathode. In this mode, thyristor is in on-state and behaves like a closed switch. Voltage drop across thyristor in the on state is of the order of 1 to 2 V depending beyond a certain point, then the reverse biased junction J_2 will have an avalanche breakdown at a voltage called forward break over voltage V_{BO} of the thyristor. But, if we keep the forward voltage less than V_{BO} , we can see from the characteristics of thyristor, that the device offers high impedance. Thus even here the thyristor operates as an open switch during the forward blocking mode.

Forward Conduction Mode

When the anode to cathode forward voltage is increased, with gate circuit open, the reverse junction J_2 will have an avalanche breakdown at forward break over voltage V_{BO} leading to thyristor turn on. Once the thyristor is turned on we can see from the diagram for characteristics of thyristor, that the point M at once shifts toward N and then anywhere between N and K. Here NK represents the forward conduction mode of the thyristor. In this mode of operation, the thyristor conducts maximum current with minimum

voltage drop, this is known as the forward conduction forward conduction or the turn on mode of the thyristor.

Two transistor analogy of SCR

Basic **operating principle of SCR**, can be easily understood by the **two transistor model of SCR** or analogy of silicon controlled rectifier, as it is also a combination of P and N layers, shown in figure below

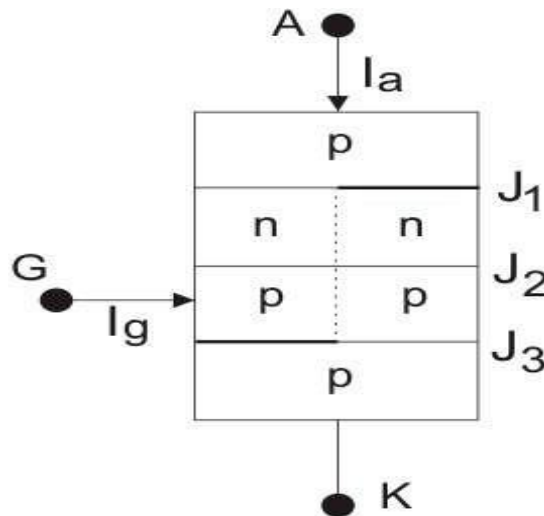

Figure: 1.10. Two transistor structure of SCR

This is a pnpn thyristor. If we bisect it through the dotted line then we will get two transistors i.e. one pnp transistor with J₁ and J₂ junctions and another is with J₂ and J₃ junctions as shown in figure below.

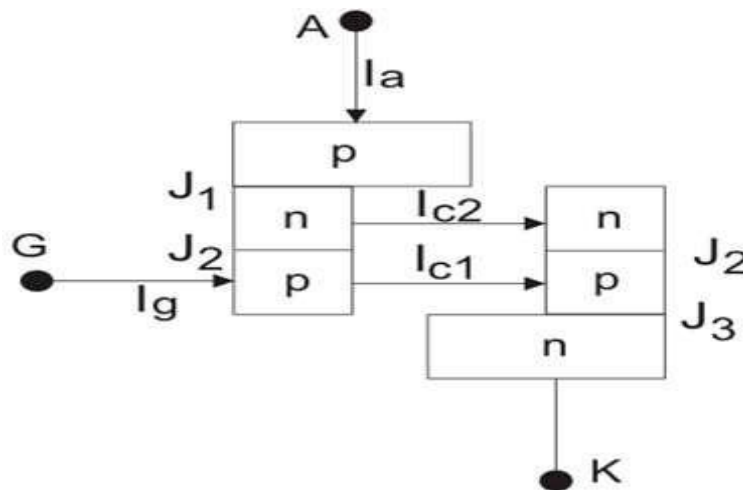

Figure: 1.11. Two transistor structure of SCR

When the transistors are in off state, the relation between the collector current and emitter current is shown below

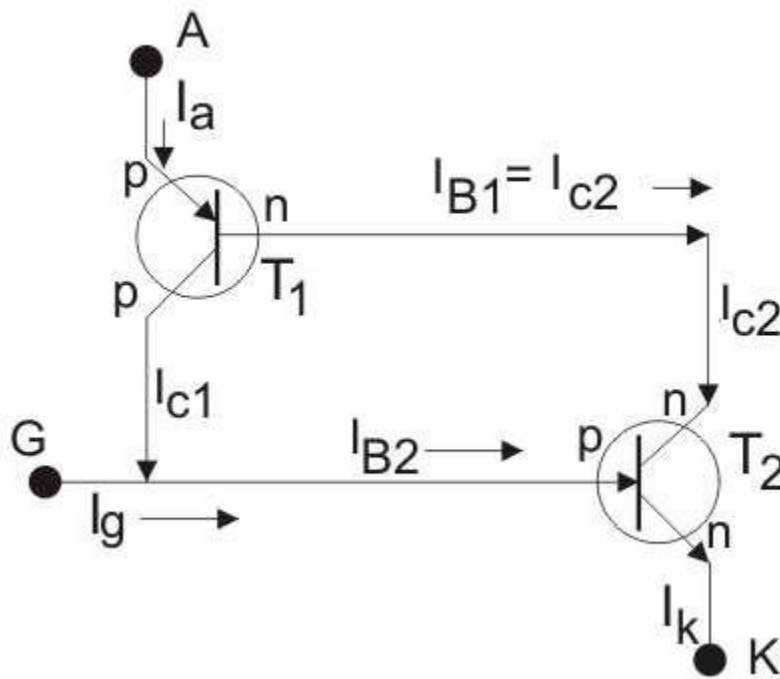

Figure: 1. 12. Two transistors connection of SCR

Here, I_C is collector current, I_E is emitter current, I_{CBO} is forward leakage current, α is common base forward current gain and relationship between I_C and I_B is $I_C = \beta I_B$ Where, I_B is base current and β is common emitter forward current gain. Let's for transistor T_1 this relation holds

$$I_{C1} = \alpha_1 I_a + I_{CBO1} \dots (i)$$

And that for transistor T_2

$$I_{C2} = \alpha_2 I_k + I_{CBO2} \dots (ii) \text{ again } I_{C2} = \beta_2 I_{B2}$$

Now, by the analysis of two transistors model we can get anode current,

$$I_a = I_{C1} + I_{C2} \text{ [applying KCL]}$$

From equation (i) and (ii), we get, $I_a = \alpha_1 I_a + I_{CBO1} + \alpha_2 I_k + I_{CBO2} \dots (iii)$

If applied gate current is I_g then cathode current will be the summation of anode current and gate current

$$\text{i.e. } I_k = I_a + I_g$$

By substituting this value of I_k in (iii) we get,

$$I_a = \alpha_1 I_a + I_{CBO1} + \alpha_2 (I_a + I_g) + I_{CBO2}$$

$$I_a = \frac{\alpha_2 I_g + I_{CBO1} + I_{CBO2}}{1 - (\alpha_1 + \alpha_2)}$$

From this relation we can assure that with increasing the value of $(\alpha_1 + \alpha_2)$ towards unity, corresponding anode current will increase. Now the question is how $(\alpha_1 + \alpha_2)$ increasing. Here is the explanation using **two transistor model of SCR**. At the first stage when we apply a gate current I_g , it acts as base current of T_2 transistor i.e. $I_{B2} = I_g$ and emitter current i.e. $I_k = I_g$ of the T_2 transistor. Hence establishment of the emitter current gives rise α_2 as

$$\alpha_2 = \frac{I_{CBO1}}{I_g}$$

Presence of base current will generate collector current as

$$I_{C2} = \beta_2 \times I_{B2} = \beta_2 I_g$$

This I_{C2} is nothing but base current I_{B1} of transistor T_1 , which will cause the flow of collector current,

$$I_{C2} = \beta_1 \times I_{B1} = \beta_1 \beta_2 I_g$$

I_{C1} and I_{B1} lead to increase I_{C1} as

$$I_a = I_{C1} + I_{B1}$$

And hence, α_1 increases. Now, new base current of T_2 is

$$I_g + I_{C1} = (1 + \beta_1 \beta_2) I_g,$$

This will lead to increase emitter current

$$I_k = I_g + I_{C1}$$

and as a result α_2 also increases and this further increases

$$I_{C2} = \beta_2(1 + \beta_1\beta_2)I_g.$$

As

$$I_{B1} = I_{C2},$$

α_1 again increases. This continuous positive feedback effect increases $(\alpha_1 + \alpha_2)$ towards unity and anode current tends to flow at a very large value. The value current then can only be controlled by external resistance of the circuit.

Turn on methods of SCR

The turning on Process of the SCR is known as Triggering. In other words, turning the SCR from Forward-Blocking state to Forward-Conduction state is known as Triggering. The various methods of SCR triggering are discussed here.

The various SCR triggering methods are

- Forward Voltage Triggering
- Thermal or Temperature Triggering
- Radiation or Light triggering
- dv/dt Triggering
- Gate Triggering

(a) Forward Voltage Triggering:-

- In this mode, an additional forward voltage is applied between anode and cathode.
- When the anode terminal is positive with respect to cathode (V_{AK}), Junction J1 and J3 is forward biased and junction J2 is reverse biased.
- No current flow due to depletion region in J2 is reverse biased (except leakage current).
- As V_{AK} is further increased, at a voltage V_{BO} (Forward Break Over Voltage) the junction J2 undergoes avalanche breakdown and so a current flows and the device tends to turn ON (even when gate is open)

(b) Thermal (or) Temperature Triggering:-

- The width of depletion layer of SCR decreases with increase in junction temperature.
- Therefore in SCR when V_{AR} is very near its breakdown voltage, the device is triggered by increasing the junction temperature.
- By increasing the junction temperature the reverse biased junction collapses thus the device starts to conduct.

(c) Radiation Triggering (or) Light Triggering:-

- For light triggered SCRs a special terminal niche is made inside the inner P layer instead of gate terminal.
- When light is allowed to strike this terminal, free charge carriers are generated.
- When intensity of light becomes more than a normal value, the thyristor starts conducting.
- This type of SCRs are called as LASCR

(d) dv/dt Triggering:-

- When the device is forward biased, J1 and J3 are forward biased, J2 is reverse biased.
- Junction J2 behaves as a capacitor, due to the charges existing across the junction.
- If voltage across the device is V , the charge by Q and capacitance by C then,
 $i_c = dQ/dt$
 $Q = CV$
 $i_c = d(CV)/dt$
 $= CdV/dt + VdC/dt$
as $dC/dt = 0$
 $i_c = CdV/dt$
- Therefore when the rate of change of voltage across the device becomes large, the device may turn ON, even if the voltage across the device is small.

(e) Gate Triggering:-

- This is most widely used SCR triggering method.
- Applying a positive voltage between gate and cathode can Turn ON a forward biased thyristor.
- When a positive voltage is applied at the gate terminal, charge carriers are injected in the inner P-layer, thereby reducing the depletion layer thickness.
- As the applied voltage increases, the carrier injection increases, therefore the voltage at which forward break-over occurs decreases.

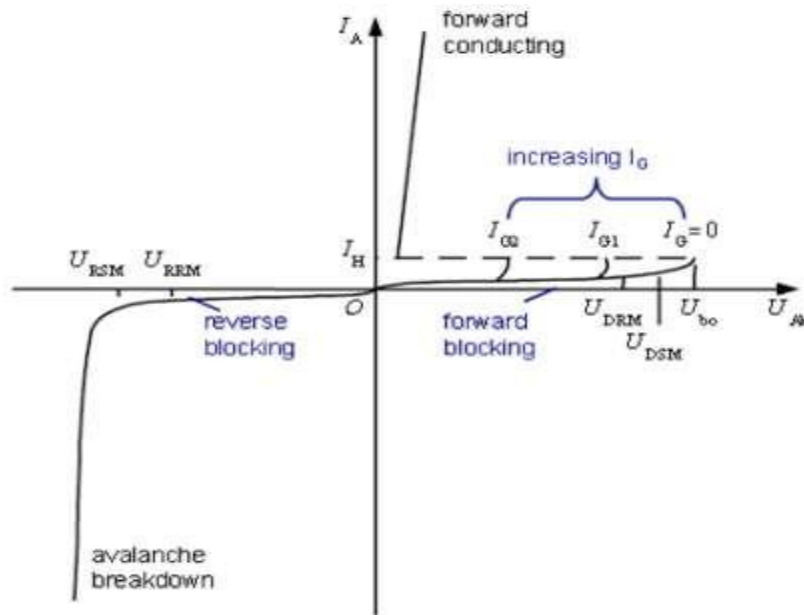

Figure: 1. 13. V - I characteristics of SCR

- Three types of signals are used for gate triggering.

1. DC gate triggering:-

- A DC voltage of proper polarity is applied between gate and cathode (Gate terminal is positive with respect to Cathode).
- When applied voltage is sufficient to produce the required gate Current, the device starts conducting.
- One drawback of this scheme is that both power and control circuits are DC and there is no isolation between the two.
- Another disadvantage is that a continuous DC signal has to be applied. So gate power loss is high.

2. AC Gate Triggering:-

- Here AC source is used for gate signals.
- This scheme provides proper isolation between power and control circuit.
- Drawback of this scheme is that a separate transformer is required to step down ac supply.
- There are two methods of AC voltage triggering namely (i) R Triggering (ii) RC triggering

(i) Resistance triggering:

The following circuit shows the resistance triggering.

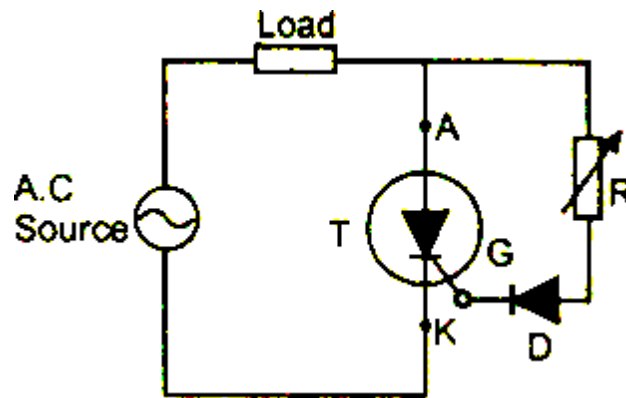

Figure: 1. 14. Resistance triggering circuit of SCR

- In this method, the variable resistance R is used to control the gate current.
- Depending upon the value of R, when the magnitude of the gate current reaches the sufficient value (latching current of the device) the SCR starts to conduct.
- The diode D is called as blocking diode. It prevents the gate cathode junction from getting damaged in the negative half cycle.
- By considering that the gate circuit is purely resistive, the gate current is in phase with the applied voltage.
- By using this method we can achieve maximum firing angle up to 90° .

(ii) RC Triggering

The following circuit shows the resistance-capacitance triggering.

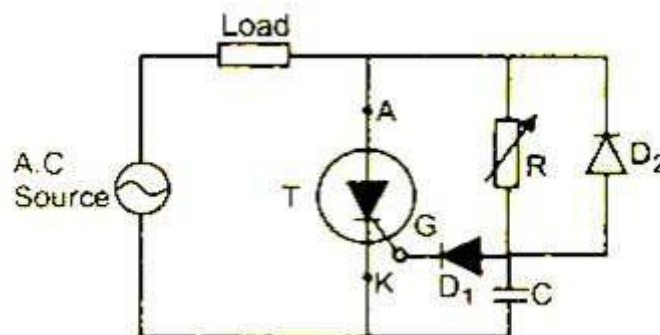

Figure: 1. 15. Resistance Capacitance triggering circuit of SCR

- By using this method we can achieve firing angle more than 90° .
- In the positive half cycle, the capacitor is charged through the variable resistance R up to the peak value of the applied voltage.
- The variable resistor R controls the charging time of the capacitor.
- Depends upon the voltage across the capacitor, when sufficient amount of gate current will flow in the circuit, the SCR starts to conduct.
- In the negative half cycle, the capacitor C is charged up to the negative peak value through the diode D2.
- Diode D1 is used to prevent the reverse break down of the gate cathode junction in the negative half cycle.

3. Pulse Gate Triggering:-

- In this method the gate drive consists of a single pulse appearing periodically (or) a sequence of high frequency pulses.
- This is known as carrier frequency gating.
- A pulse transformer is used for isolation.
- The main advantage is that there is no need of applying continuous signals, so the gate losses are reduced.

Advantages of pulse train triggering:

- Low gate dissipation at higher gate current.
- Small gate isolating pulse transformer
- Low dissipation in reverse biased condition is possible. So simple trigger circuits are possible in some cases
- When the first trigger pulse fails to trigger the SCR, the following pulses can succeed in latching SCR. This important while
- Triggering inductive circuits and circuits having back emf's.

Turn off methods of SCR:

SCR can be turned ON by applying appropriate positive gate voltage between the gate and cathode terminals, but it cannot be turned OFF through the gate terminal. The SCR can be brought back to the

forward blocking state from the forward conduction state by reducing the anode or forward current below the holding current level.

The turn OFF process of an SCR is called **commutation**. The term commutation means the transfer of currents from one path to another. So the commutation circuit does this job by reducing the forward current to zero so as to turn OFF the SCR or Thyristor.

To turn OFF the conducting SCR the below conditions must be satisfied.

- The anode or forward current of SCR must be reduced to zero or below the level of holding current and then,
- A sufficient reverse voltage must be applied across the SCR to regain its forward blocking state.

When the SCR is turned OFF by reducing forward current to zero there exist excess charge carriers in different layers. To regain the forward blocking state of an SCR, these excess carriers must be recombined. Therefore, this recombination process is accelerated by applying a reverse voltage across the SCR.

SCR Turn OFF Methods

The reverse voltage which causes to commutate the SCR is called commutation voltage. Depending on the commutation voltage located, the commutation methods are classified into two major types.

Those are 1) Forced commutation and 2) Natural commutation. Let us discuss in brief about these methods.

Forced Commutation

In case of DC circuits, there is no natural current zero to turn OFF the SCR. In such circuits, forward current must be forced to zero with an external circuit to commutate the SCR hence named as forced commutation.

This commutating circuit consists of components like inductors and capacitors called as commutating components. These commutating components cause to apply a reverse voltage across the SCR that immediately bring the current in the SCR to zero.

Based on the manner in which the zero current is achieved and arrangement of the commutating components, forced commutation is classified into different types such as class A, B, C, D, and E. This commutation is mainly used in chopper and inverter circuits.

Class A Commutation

This is also known as self commutation, or resonant commutation, or load commutation. In this commutation, the source of commutation voltage is in the load. This load must be an under damped R-L-C supplied with a DC supply so that natural zero is obtained.

The commutating components L and C are connected either parallel or series with the load resistance R as shown below with waveforms of SCR current, voltage and capacitor voltage.

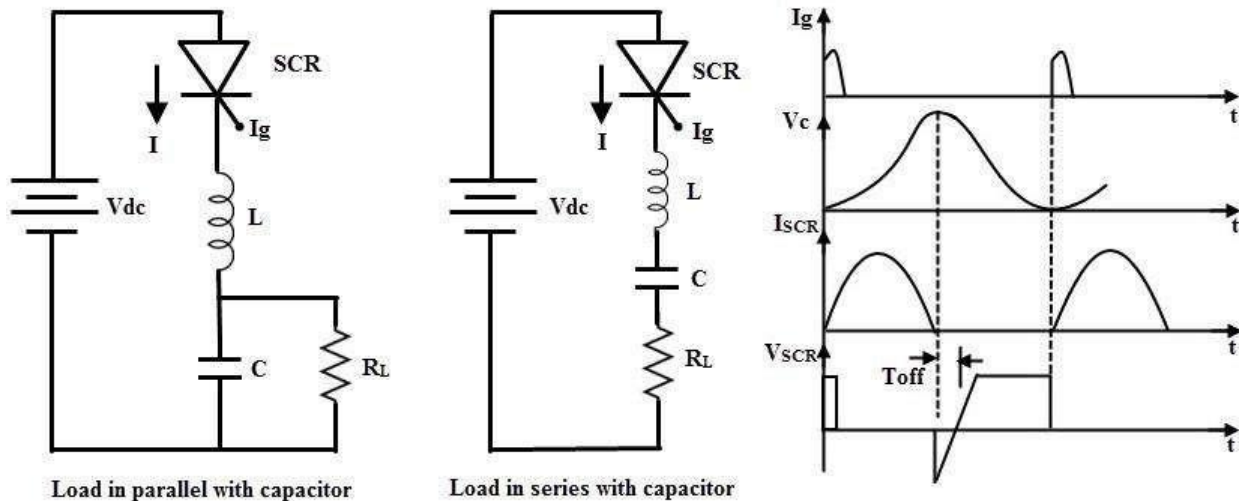

Figure: 1. 16. Class A Commutation circuit and waveforms

The value of load resistance and commutating components are so selected that they forms a under damped resonant circuit to produce natural zero. When the thyristor or SCR is triggered, the forward currents starts flowing through it and during this the capacitor is charged up to the value of E.

Once the capacitor is fully charged (more than the supply source voltage) the SCR becomes reverse biased and hence the commutation of the device. The capacitor discharges through the load resistance to make ready the circuit for the next cycle of operation. The time for switching OFF the SCR depends on the resonant frequency which further depends on the L and C components.

This method is simple and reliable. For high frequency operation which is in the range above 1000 Hz, this type of commutation circuits is preferred due to the high values of L and C components.

Class B Commutation

This is also a self commutation circuit in which commutation of SCR is achieved automatically by L and C components, once the SCR is turned ON. In this, the LC resonant circuit is connected across the SCR but not in series with load as in case of class A commutation and hence the L and C components do not carry the load current.

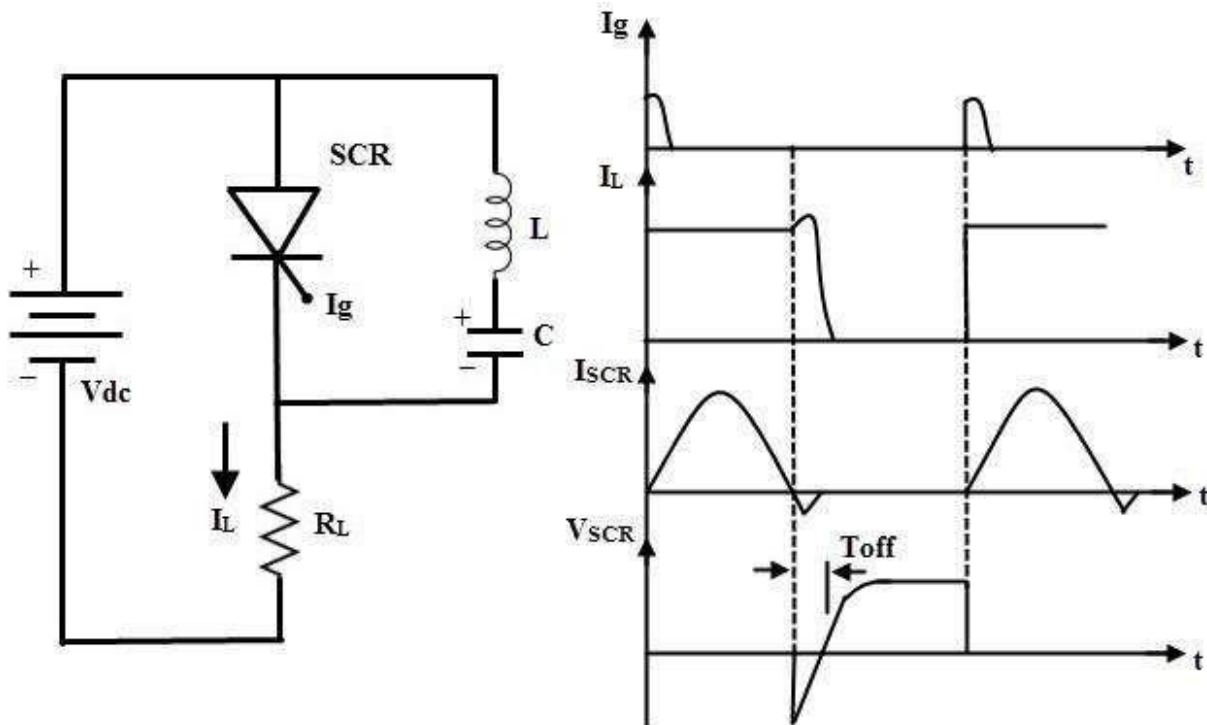

Figure: 1. 17. Class B Commutation circuit and waveforms

When the DC supply is applied to the circuit, the capacitor charges with an upper plate positive and lower plate negative up to the supply voltage E . When the SCR is triggered, the current flows in two directions, one is through $E+ - SCR - R - E-$ and another one is the commutating current through L and C components.

Once the SCR is turned ON, the capacitor starts discharging through $C+ - L - T - C-$. When the capacitor is fully discharged, it starts charging with a reverse polarity. Hence a reverse voltage applied across the SCR which causes the commutating current I_C to oppose load current I_L .

When the commutating current I_c is higher than the load current, the SCR will automatically turn OFF and the capacitor charges with original polarity.

In the above process, the SCR is turned ON for some time and then automatically turned OFF for some time. This is a continuous process and the desired frequency of ON/OFF depends on the values of L and C. This type of commutation is mostly used in chopper circuits.

Class C Commutation

In this commutation method, the main SCR is to be commutated is connected in series with the load and an additional or complementary SCR is connected in parallel with main SCR. This method is also called as complementary commutation.

In this , SCR turns OFF with a reverse voltage of a charged capacitor. The figure below shows the complementary commutation with appropriate waveforms.

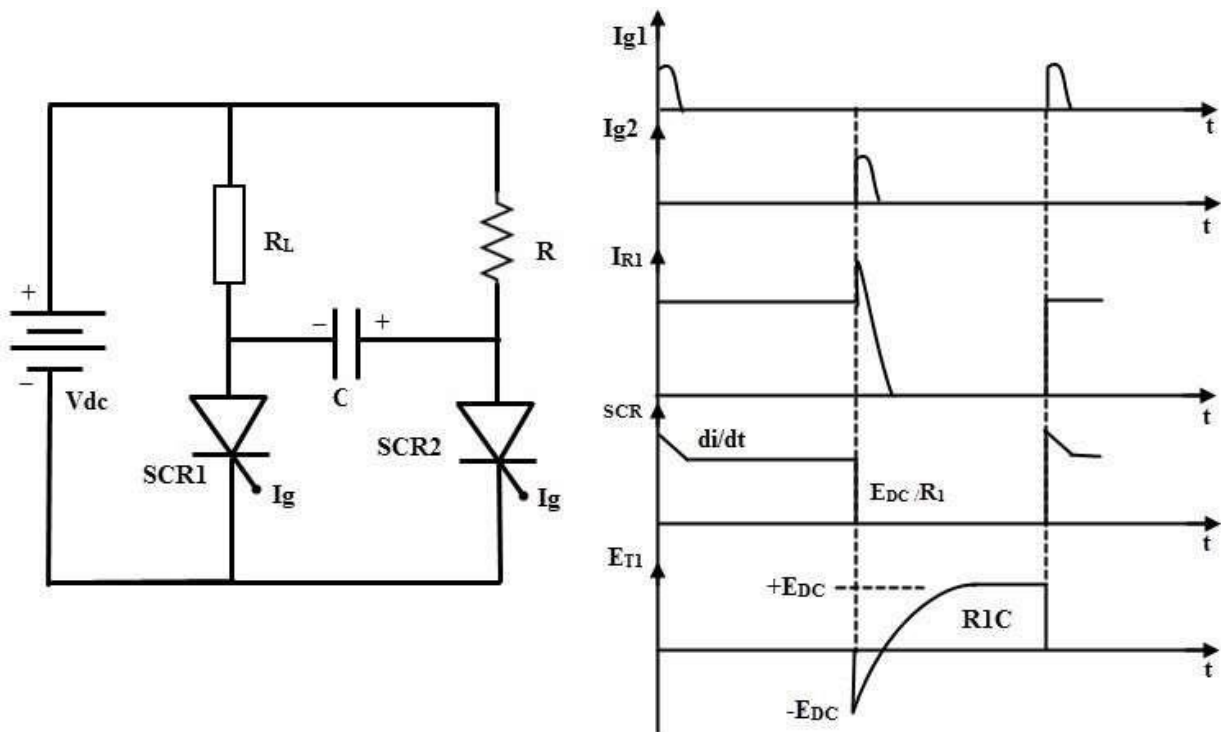

Figure: 1. 18. Class C Commutation circuit and waveforms

Initially, both SCRs are in OFF state so the capacitor voltage is also zero. When the SCR1 or main SCR is triggered, current starts flowing in two directions, one path is $E^+ - R_1 - SCR1 - E^-$ and another path is the charging current $E^+ - R_2 - C^+ - C^- - SCR1 - E^-$. Therefore, the capacitor starts charging up to the value of E .

When the SCR2 is triggered, SCR1 is turned ON and simultaneously a negative polarity is applied across the SCR1. So this reverse voltage across the SCR1 immediately causes to turn OFF the SCR1. Now the capacitor starts charging with a reverse polarity through the path of $E+ - R1- C+ - C- - SCR2 - E-$. And again, if the SCR1 is triggered, discharging current of the capacitor turns OFF the SCR2.

This commutation is mainly used in single phase inverters with a centre tapped transformers. The Mc Murray Bedford inverter is the best example of this commutation circuit. This is a very reliable method of commutation and it is also useful even at frequencies below 1000Hz.

Class D Commutation

This is also called as auxiliary commutation because it uses an auxiliary SCR to switch the charged capacitor. In this, the main SCR is commutated by the auxiliary SCR. The main SCR with load resistance forms the power circuit while the diode D, inductor L and SCR2 forms the commutation circuit.

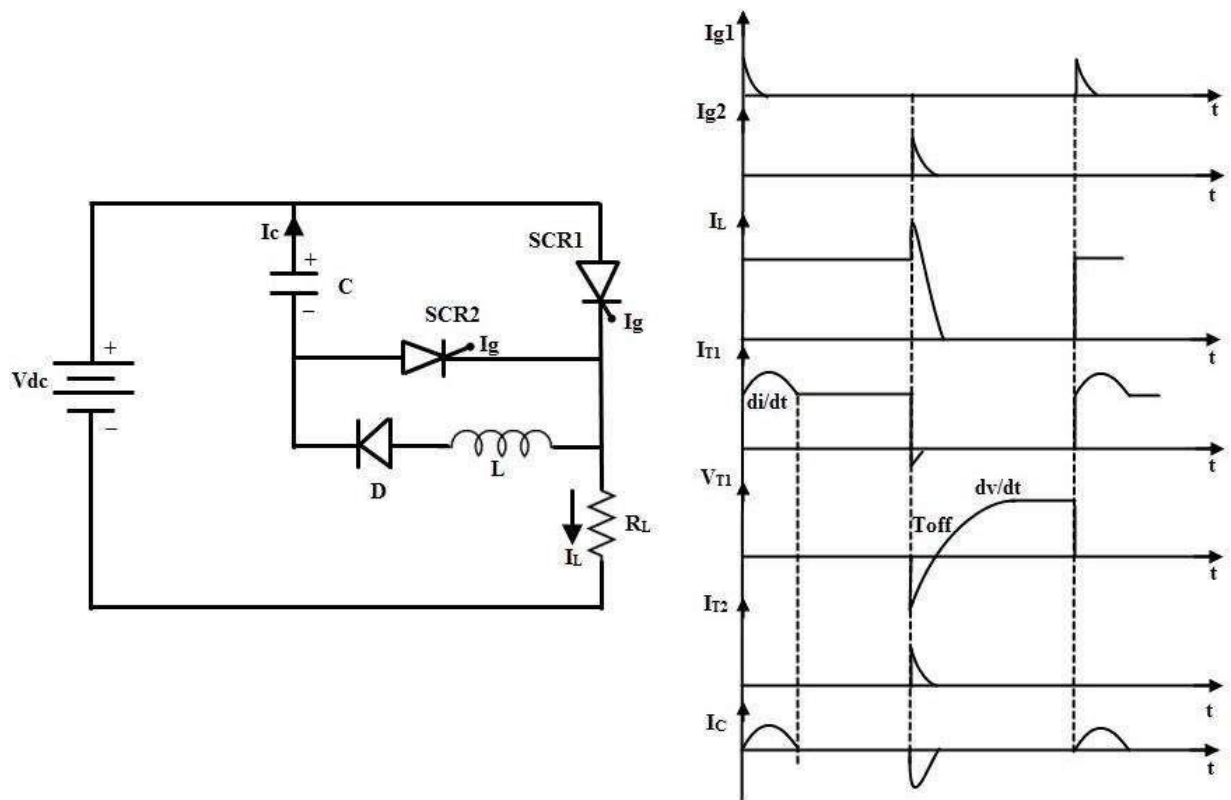

Figure: 1. 19. Class D Commutation circuit and waveforms

When the supply voltage E is applied, both SCRs are in OFF state and hence the capacitor voltage is zero. In order to charge the capacitor, SCR2 must be triggered first. So the capacitor charges through the path $E+ - C+ - C- - SCR2- R- E-$.

When the capacitor is fully charged the SCR2 becomes turned OFF because no current flow through the SCR2 when capacitor is charged fully. If the SCR1 is triggered, the current flows in two directions; one is the load current path $E+ - SCR1 - R - E-$ and another one is commutation current path $C+ - SCR1 - L - D - C$.

As soon as the capacitor completely discharges, its polarities will be reversed but due to the presence of diode the reverse discharge is not possible. When the SCR2 is triggered capacitor starts discharging through $C+ - SCR2 - SCR1 - C-$. When this discharging current is more than the load current the SCR1 becomes turned OFF.

Again, the capacitor starts charging through the SCR2 to a supply voltage E and then the SCR2 is turned OFF. Therefore, both SCRs are turned OFF and the above cyclic process is repeated. This commutation method is mainly used in inverters and also used in the Jones chopper circuit.

Class E Commutation

This is also known as external pulse commutation. In this, an external pulse source is used to produce the reverse voltage across the SCR. The circuit below shows the class E commutation circuit which uses a pulse transformer to produce the commutating pulse and is designed with tight coupling between the primary and secondary with a small air gap.

If the SCR need to be commutated, pulse duration equal to the turn OFF time of the SCR is applied. When the SCR is triggered, load current flows through the pulse transformer. If the pulse is applied to the primary of the pulse transformer, an emf or voltage is induced in the secondary of the pulse transformer.

This induced voltage is applied across the SCR as a reverse polarity and hence the SCR is turned OFF. The capacitor offers a very low or zero impedance to the high frequency pulse.

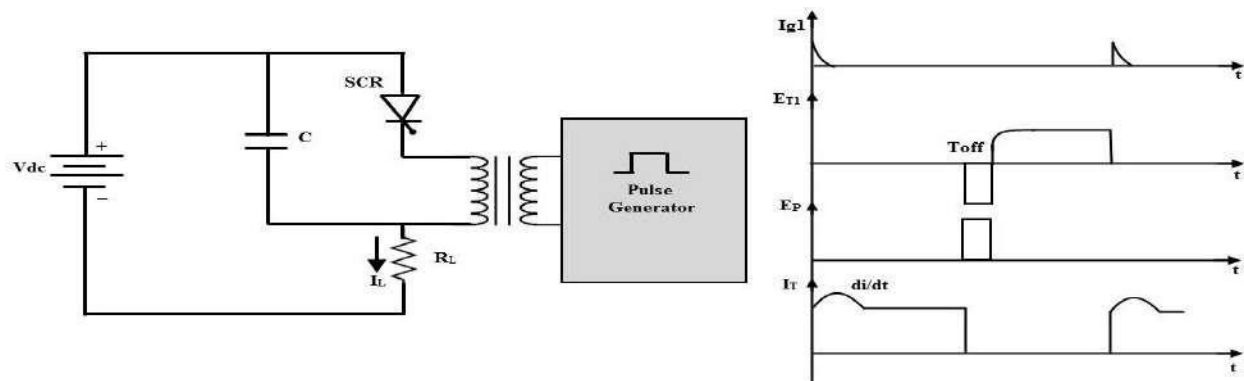

Figure: 1. 20. Class E Commutation circuit and waveforms

Natural Commutation

In natural commutation, the source of commutation voltage is the supply source itself. If the SCR is connected to an AC supply, at every end of the positive half cycle the anode current goes through the natural current zero and also immediately a reverse voltage is applied across the SCR. These are the conditions to turn OFF the SCR.

This method of commutation is also called as source commutation, or line commutation, or class F commutation. This commutation is possible with line commutated inverters, controlled rectifiers, cyclo converters and AC voltage regulators because the supply is the AC source in all these converters.

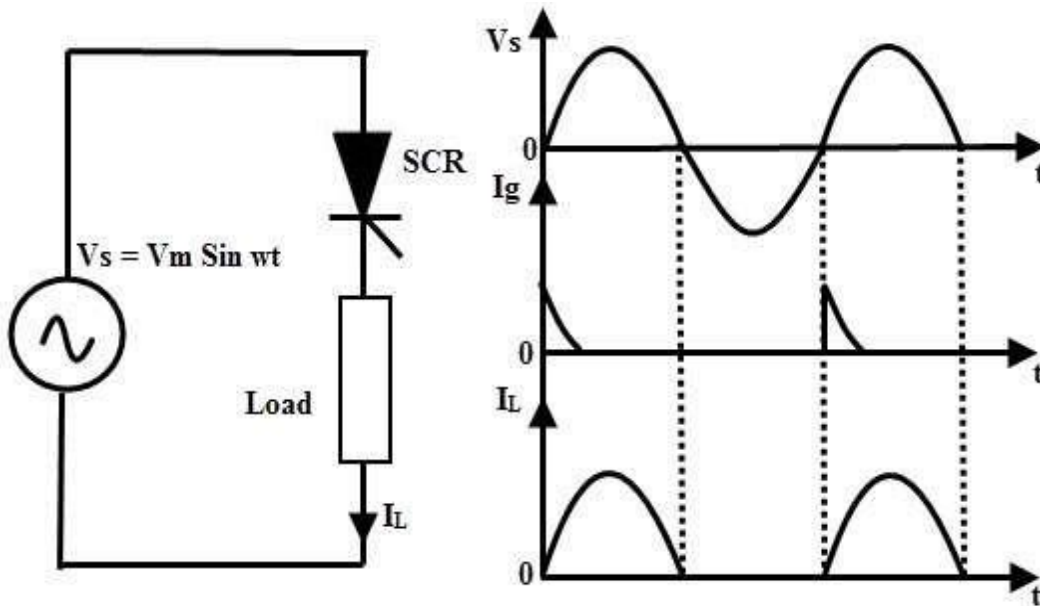

Figure: 1. 21. Natural Commutation circuit and waveforms

Dynamic Turn OFF Switching Characteristics

The transition of an SCR from forward conduction state to forward blocking state is called as turn OFF or commutation of SCR. As we know that once the SCR starts conducting, the gate has no control over it to bring back to forward blocking or OFF state.

To turn OFF the SCR, the current must be reduced to a level below the holding current of SCR. We have discussed various methods above to turn OFF the SCR in which SCR turn OFF is achieved by reducing

the forward current to zero. But if we apply the forward voltage immediately after the current zero of SCR, it starts conducting again even without gate triggering.

This is due to the presence of charge carriers in the four layers. Therefore, it is necessary to apply the reverse voltage, over a finite time across the SCR to remove the charge carriers.

Hence the turn OFF time is defined as the time between the instant the anode current becomes zero and the instant at which the SCR retains the forward blocking capability. The excess charge carriers from the four layers must be removed to bring back the SCR to forward conduction mode.

This process takes place in two stages. In a first stage excess carriers from outer layers are removed and in second stage excess carriers in the inner two layers are to be recombined. Hence, the total turn OFF time t_q is divided into two intervals; reverse recovery time t_{rr} and gate recovery time t_{gr} .

$$t_q = t_{rr} + t_{gr}$$

The figure below shows the switching characteristics of SCR during turn ON and OFF. The time t_1 to t_3 is called as reverse recovery time; at the instant t_1 the anode current is zero and builds up in the reverse direction which is called as reverse recovery current. This current removes the excess charge carriers from outer layers during the time t_1 to t_3 .

At instant t_3 , junctions J_1 and J_3 are able to block the reverse voltage but, the SCR is not yet able to block the forward voltage due to the presence of excess charge carriers in junction J_2 . These carriers can be disappeared only by the way of recombination and this could be achieved by maintaining a reverse voltage across the SCR.

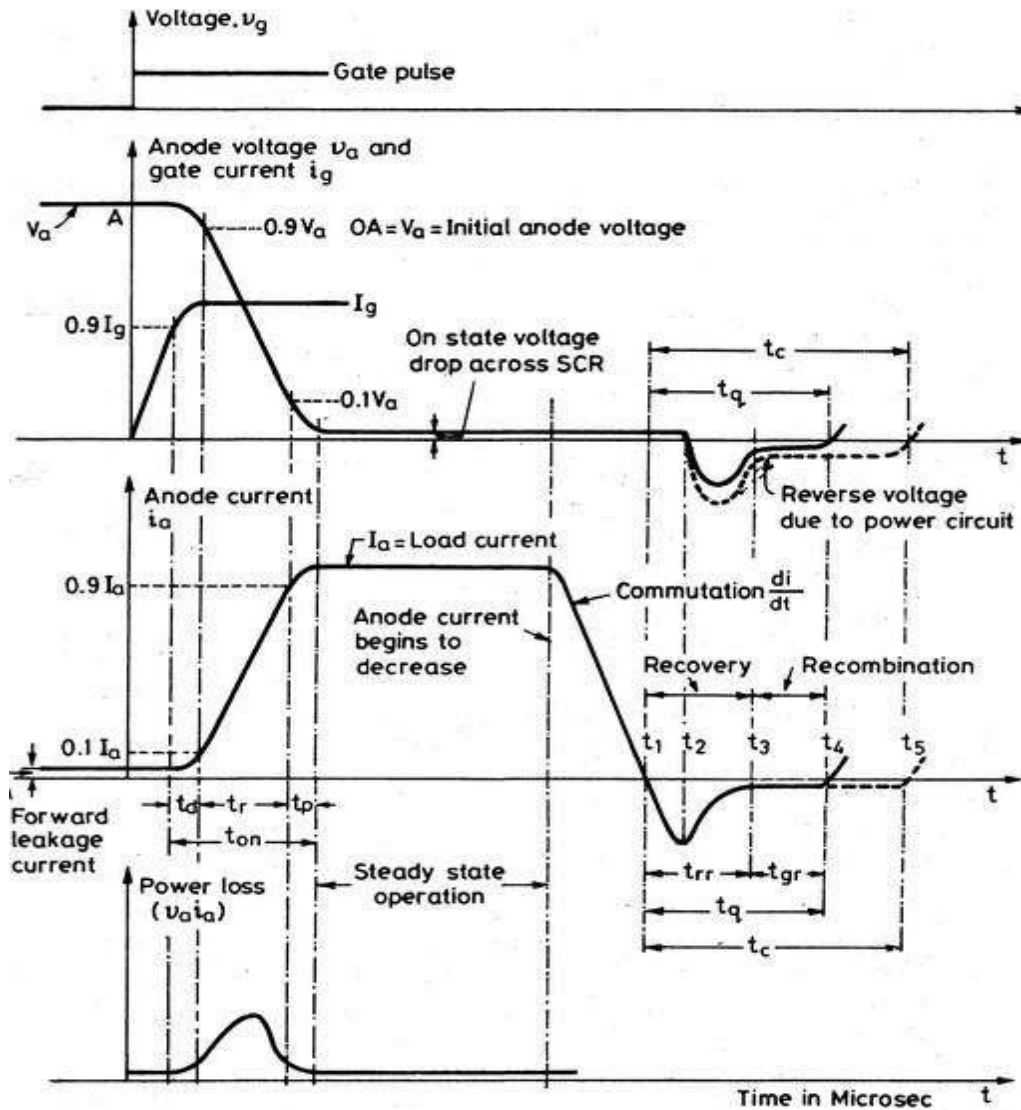

Figure: 1. 22. Dynamic characteristics of SCR

Hence , during the time t_3 to t_4 , the recombination of charges takes place and at the instant t_4 , junction J_2 completely recovers. This time is called gate recovery time t_{gr} .

- From the figure the turn OFF time is the time interval between the t_4 and t_1 . Generally, this time varies from 10 to 100 microseconds. This turn OFF time t_q is applicable to the individual SCR.
- The time required by the commutation circuit to apply the reverse voltage to commutate the SCR is called the circuit turn OFF time (t_c). For a safety margin or reliable commutation, this t_c must be greater than the t_q otherwise commutation failure occurs.

- The SCRs which have slow turn OFF time as in between 50 to 100 microseconds are called as converter grade SCRs. These are used in phase controlled rectifiers, cyclo converters, AC voltage regulators, etc.
- The SCRs which have fast turn OFF time as in between 3 to 50 microseconds are inverter grade SCRs. These are costlier compared to converter grade and are used in choppers, force commutated converters and inverters.

Resistance Firing Circuit

- The circuit below shows the resistance triggering of SCR where it is employed to drive the load from the input AC supply. Resistance and diode combination circuit acts as a gate control circuitry to switch the SCR in the desired condition.
- As the positive voltage applied, the SCR is forward biased and doesn't conduct until its gate current is more than minimum gate current of the SCR.
- When the gate current is applied by varying the resistance R2 such that the gate current should be more than the minimum value of gate current, the SCR is turned ON. And hence the load current starts flowing through the SCR.
- The SCR remains ON until the anode current is equal to the holding current of the SCR. And it will switch OFF when the voltage applied is zero. So the load current is zero as the SCR acts as open switch.
- The diode protects the gate drive circuit from reverse gate voltage during the negative half cycle of the input. And Resistance R1 limits the current flowing through the gate terminal and its value is such that the gate current should not exceed the maximum gate current.
- It is the simplest and economical type of triggering but limited for few applications due to its disadvantages.
- In this, the triggering angle is limited to 90 degrees only. Because the applied voltage is maximum at 90 degrees so the gate current has to reach minimum gate current value somewhere between zero to 90 degrees.

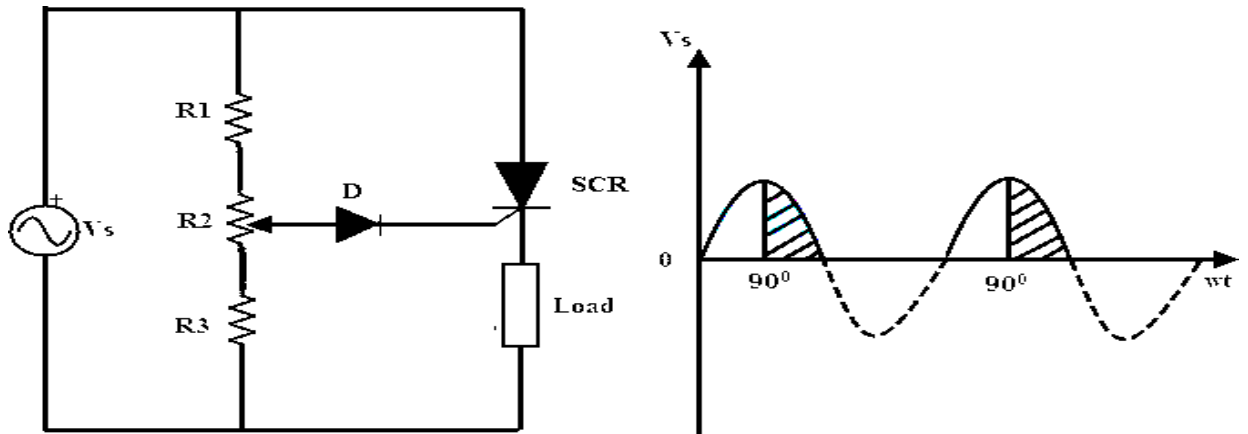

Figure: 1. 23. R Firing circuit for SCR and corresponding waveforms

Resistance – Capacitance (RC) Firing Circuit

- The limitation of resistance firing circuit can be overcome by the RC triggering circuit which provides the firing angle control from 0 to 180 degrees. By changing the phase and amplitude of the gate current, a large variation of firing angle is obtained using this circuit.
- Below figure shows the RC triggering circuit consisting of two diodes with an RC network connected to turn the SCR.
- By varying the variable resistance, triggering or firing angle is controlled in a full positive half cycle of the input signal.
- During the negative half cycle of the input signal, capacitor charges with lower plate positive through diode D2 up to the maximum supply voltage V_{max} . This voltage remains at $-V_{max}$ across the capacitor till supply voltage attains zero crossing.
- During the positive half cycle of the input, the SCR becomes forward biased and the capacitor starts charging through variable resistance to the triggering voltage value of the SCR.
- When the capacitor charging voltage is equal to the gate trigger voltage, SCR is turned ON and the capacitor holds a small voltage. Therefore the capacitor voltage is helpful for triggering the SCR even after 90 degrees of the input waveform.
- In this, diode D1 prevents the negative voltage between the gate and cathode during the negative half cycle of the input through diode D2.

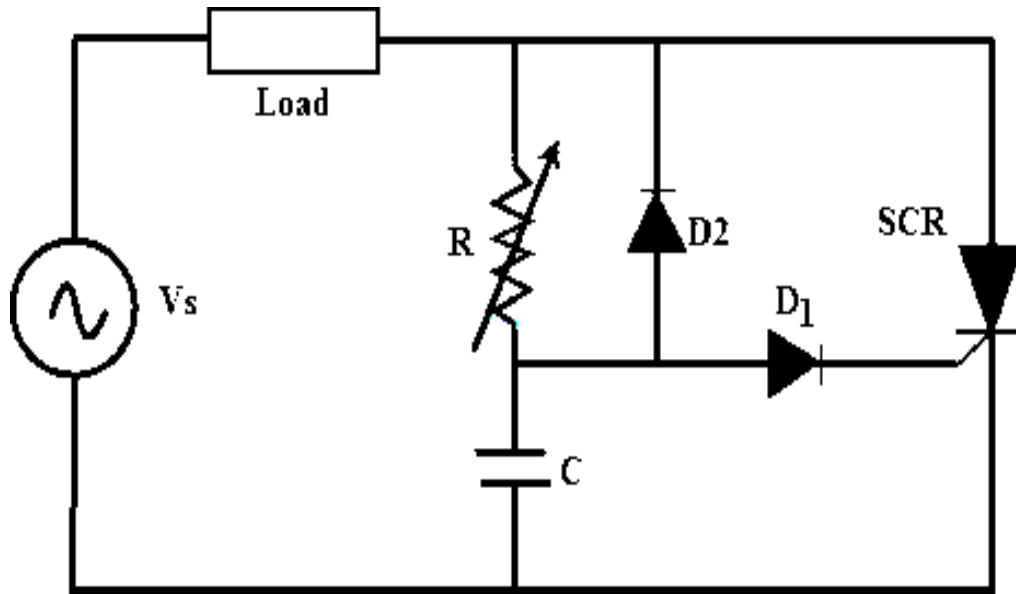

Figure: 1. 24. R Firing circuit for SCR

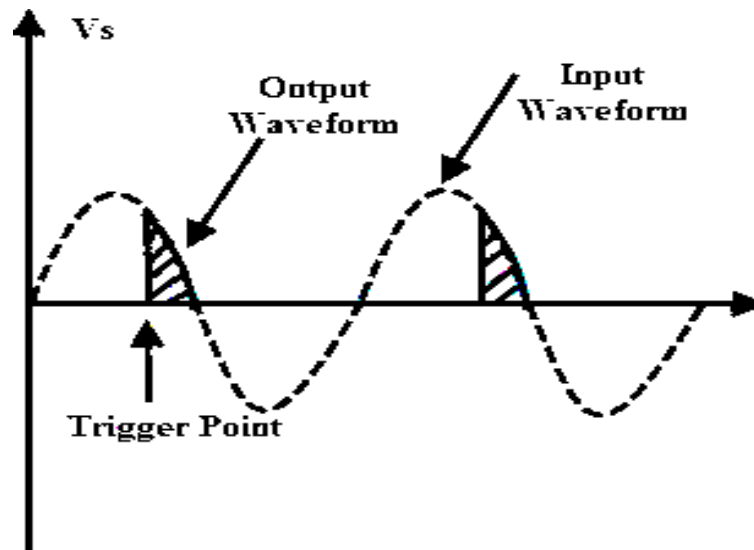

Figure: 1. 25. R Firing circuit waveforms of SCR

UJT Firing Circuit

- It is the most common method of triggering the SCR because the prolonged pulses at the gate using R and RC triggering methods cause more power dissipation at the gate so by using UJT (Uni Junction Transistor) as triggering device the power loss is limited as it produce a train of pulses.
- The RC network is connected to the emitter terminal of the UJT which forms the timing circuit. The capacitor is fixed while the resistance is variable and hence the charging rate of the capacitor depends on the variable resistance means that the controlling of the RC time constant.
- When the voltage is applied, the capacitor starts charging through the variable resistance. By varying the resistance value voltage across the capacitor get varied. Once the capacitor voltage is equal to the peak value of the UJT, it starts conducting and hence produce a pulse output till the voltage across the capacitor equal to the valley voltage V_v of the UJT. This process repeats and produces a train of pulses at base terminal 1.
- The pulse output at the base terminal 1 is used to turn ON the SCR at predetermined time intervals

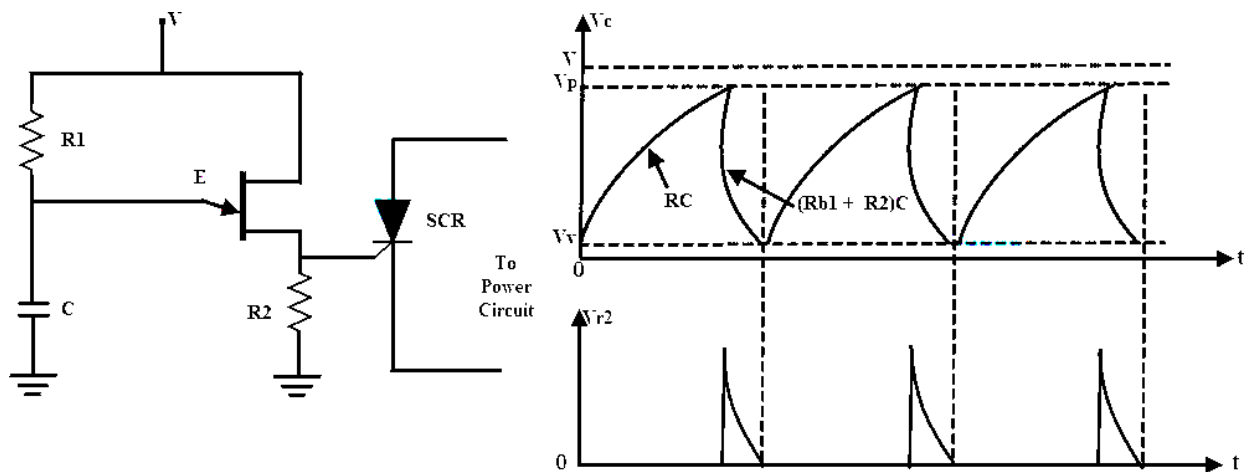

Figure: 1. 26. UJT Firing circuit for SCR and corresponding waveforms

Series and Parallel connections of SCRs

In many power control applications the required voltage and current ratings exceed the voltage and current that can be provided by a single SCR. Under such situations the SCRs are required to be connected in series or in parallel to meet the requirements. Sometimes even if the required rating is available, multiple connections are employed for reasons of economy and easy availability of SCRs of lower ratings. Like any other electrical equipment, characteristics/properties of two SCRs of same make and ratings are never same and this leads to certain problems in the circuit. The mismatching of SCRs is due to differences in

- (i) turn-on time
- (ii) turn-off time
- (iii) Leakage current in forward direction
- (iv) Leakage current in reverse direction and
- (v) Recovery voltage.

Series Connection of an SCR

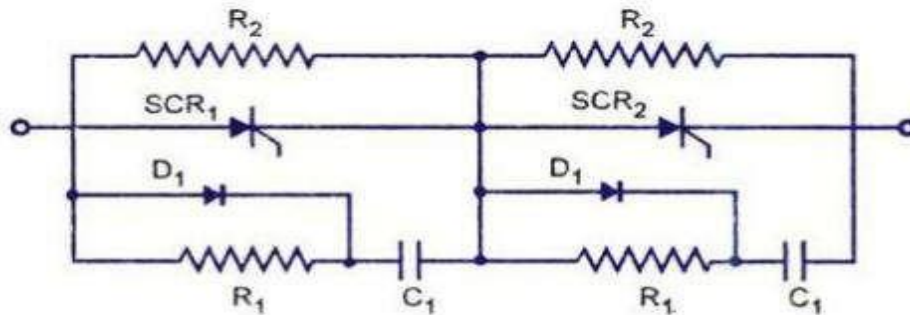

Figure: 1. 27. Series connection of SCRs

- (i) Unequal distribution of voltage across SCRs
- (ii) Difference in recovery characteristics.

Care must be taken to share the voltage equally. For steady-state conditions, voltage sharing is achieved by using a resistance or a Zener diode in parallel with each SCR. For transient voltage sharing a low non-inductive resistor and capacitor in series are placed across each SCR, as shown in figure. Diodes D₁ connected in parallel with resistor R₁, helps in dynamic stabilization. This circuit reduces differences between blocking voltages of the two devices within permissible limits. Additionally the R-C circuit can also serve the function of ‘snubber circuit’. Values of R₁ and C₁ can primarily be calculated for snubber circuit and a check can be made for equalization. If ΔQ is the difference in recovery charge of two devices arising out of different recovery current for different time and ΔV is the permissible difference in blocking voltage then

$$C_1 = \Delta Q / \Delta V$$

The value of resistance R_x should be sufficient to over damp the circuit. Since the capacitor C₁ can discharge through the SCR during turn-on, there can be excessive power dissipation, but the switching current from C₁ is limited by the resistor R₁. This resistance also serves the purpose of

damping out 'ringing' which is oscillation of C1 with the circuit inductance during commutation. All the SCRs connected in series should be turned-on at the same time when signals are applied to their gates simultaneously.

$$\text{String efficiency} = \frac{\text{Voi or actual current rating of the whole string}}{\text{No of SCRs in string} \times \text{Voi or current rating of individual SCR}}$$

This phenomenon increases the reliability of the string, but reduces the utilization of each SCR. Thus string efficiency decreases. Reliability of string is measured by derating factor (DRF) which is given by the expression

$$\text{DRF} = 1 - \text{string efficiency}$$

Parallel Connection of an SCR

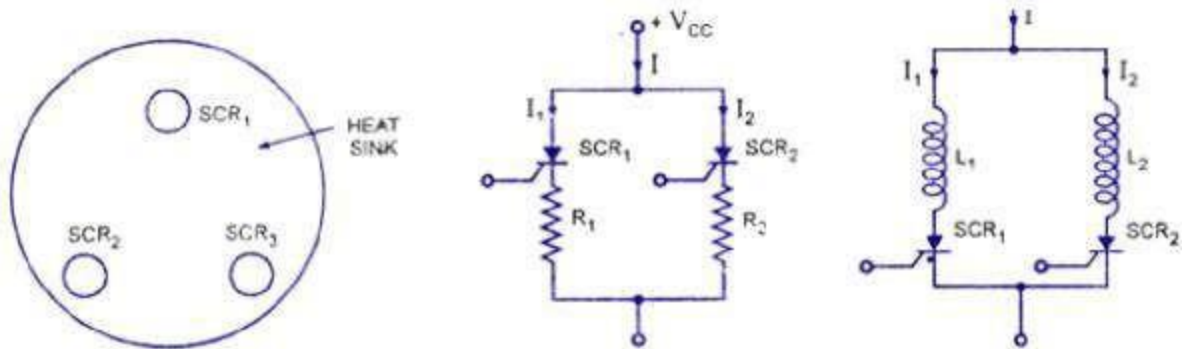

Figure: 1. 28. Parallel connection of SCRs

When the load current exceeds the SCR current rating, SCRs are connected in parallel to share the load current. But when SCRs are operated in parallel, the current sharing between them may not be proper. The device having lower dynamic resistance will tend to share more current. This will raise the temperature of that particular device in comparison to other, thereby reducing further its dynamic resistance and increasing current through it. This process is cumulative and continues till the device gets punctured. Some other factors which directly or indirectly add to this problem are difference in turn-on time, delay time, finger voltage and loop inductance.

Arrangement of SCRs in the cubicle also plays vital role. When the SCRs are connected in parallel, it must be ensured that the latching current level of the all the SCRs is such that when gate pulse is applied, all of them turn-on and remain on when the gate pulse is removed. Further the holding

currents of the devices should not be so much different that at reduced load current one of the device gets turned-off because of fall of current through it below its holding current value. This is particularly important because on increase in load current, the device which has stopped conducting cannot start in the absence of gate pulse.

Another point to be considered is the on-state voltage across the device. For equal sharing of currents by the devices voltage drop across the parallel paths must be equal. For operation of all the SCRs connected in parallel at the same temperature, it becomes necessary to use a common heat sink for their mounting, as illustrated in figure. Resistance compensation used for dc circuits is shown in figure. In this circuit the resistors R_x and R_2 are chosen so as to cause equal voltage drop in both arms. Inductive compensation used for ac circuits is shown in figure. The difference in characteristics due to different turn-on time, delay time, finger voltage, latching current, holding current can be minimized by using inductive compensation. Firing circuits giving high rate of rise can be used to reduce mismatch of gate characteristics and delay time. Current sharing circuits must be designed so as to distribute current equally at maximum temperature and maximum anode current. This is done to ensure that the devices share current equally under worst operating conditions. Mechanical arrangement of SCRs also plays an important role in reducing mismatching. Cylindrical construction is perhaps the best from this point of view.

Derating:

Even with all the measures taken, it is preferable to derate the device for series/parallel operation. Another reason for derating is poor cooling and heat dissipation as number of devices operates in the same branch of the circuit. Normal derating factors are 10 to 15% for parallel connection of SCRs depending upon the number of devices connected in parallel. Higher voltage safety factor is taken when SCRs are connected in series.

Numerical Problems:

1. The trigger circuit of a thyristor has a source voltage of 15V and the load line has a slope of -120V per ampere. The minimum gate current to turn on the SCR is 25mA. Compute
 - i. Source resistance required in the gate circuit
 - ii. The trigger voltage and trigger current for an average gate power dissipation of 0.4 watts

Solution:

- i. The slope of load line gives the required gate source resistance. From the load line, series resistance required in the gate circuit is 120Ω
- ii. Here $V_g I_g = 0.4W$

For the gate circuit $E_s = R_s I_g + V_g$

$$15 = 120I_g + 0.4/I_g$$

$$120I_g^2 - 15 I_g + 0.4 = 0$$

Its solution gives $I_g = 38.56mA$ or $86.44 mA$

$$V_g = \frac{0.4 \times 1000}{38.56} = 10.37V$$

$$V_g = \frac{0.4 \times 1000}{.44} = 4.627V$$

So choose the value for I_g which gives less voltage $I_g = 86.44 mA$ and $V_g = 4.627V$ from minimum gate current of 25mA.

2. For an SCR the gate-cathode characteristic has a straight line slope of 130. For trigger source voltage of 15V and allowable gate power dissipation of 0.5 watts, compute the gate source resistance.
3. SCRs with a rating of 1000V and 200A are available to be used in a string to handle 6kV and 1kA. Calculate the number of series and parallel units required in case de-rating factor is 0.1 and 0.2

4. It is required to operate 250A SCR in parallel with 350A SCR with their respective on state voltage drops of 1.6V and 1.2V. Calculate the value of resistance to be inserted in series with each SCR so that they share the total load of 600A in proportion to their current ratings.

Snubber circuit

Due to overheating, over voltage, over current or excessive change in voltage or current switching devices and circuit components may fail. From over current they can be protected by placing fuses at suitable locations. Heat sinks and fans can be used to take the excess heat away from switching devices and other components. Snubber circuits are needed to limit the rate of change in voltage or current (**di/dt** or **dv/dt**) and over voltage during turn-on and turn-off. These are placed across the semiconductor devices for protection as well as to improve the performance. Static **dv/dt** is a measure of the ability of a thyristor to retain a blocking state under the influence of a voltage transient. These are also used across the relays and switches to prevent arcing.

Necessity of Using the Snubber Circuit

These are placed across the various switching devices like transistors, thyristors, etc. Switching from ON to OFF state results the impedance of the device suddenly changes to the high value. But this allows a small current to flow through the switch. This induces a large voltage across the device. If this current reduced at faster rate more is the induced voltage across the device and also if the switch is not capable of withstanding this voltage the switch becomes burn out. So auxiliary path is needed to prevent this high induced voltage

Similarly when the transition is from OFF to ON state, due to uneven distribution of the current through the area of the switch overheating will takes place and eventually it will be burned. Here also snubber is necessary to reduce the current at starting by making an alternate path.

Snubbers in switching mode provides one or more of the following functions

- Shape the load line of a bipolar switching transistor to keep it in its safe operating area.
- Reducing the voltages and currents during turn-ON and turn-OFF transient conditions.
- Removes energy from a switching transistor and dissipate the energy in a resistor to reduce junction temperature.
- Limiting the rate of change of voltage and currents during the transients.
- Reduce ringing to limit the peak voltage on a switching transistor and lowering their frequency.

Design of RC Snubber Circuits:

There are many kinds of snubbers like RC, diode and solid state snubbers but the most commonly used one is RC snubber circuit. This is applicable for both the rate of rise control and damping.

This circuit is a capacitor and series resistor connected across a switch. For designing the Snubber circuits. The amount of energy is to dissipate in the snubber resistance is equal to the amount of energy is stored in the capacitors. An RC Snubber placed across the switch can be used to reduce the peak voltage at turn-off and to damp the ring. An RC snubber circuit can be polarized or non-polarized. If you assume the source has negligible impedance, the worst case peak current in the snubber circuit is

$$I = V_0/R_s \text{ and } I = C \cdot dv/dt$$

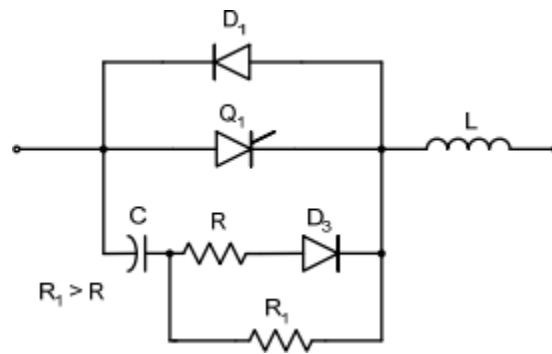

Figure: 1. 29. Forward-Polarized RC Snubber Circuit

For an appropriate forward-polarized RC snubber circuit a thyristor or a transistor is connected with an anti-parallel diode. R will limit the forward dv/dt and R_1 limits the discharge current of the capacitor when thyristor Q_1 is turned on. These are used as overvoltage snubbers to clamp the voltage.

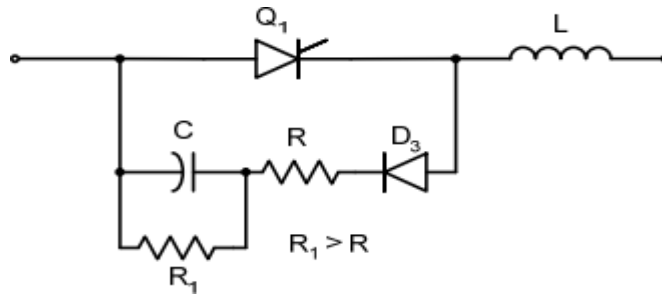

Figure: 1. 30. Reverse Polarized RC Snubber Circuit

Reverse polarized snubber circuit can be used to limit the reverse dv/dt . R1 will limit the discharge current of the capacitor.

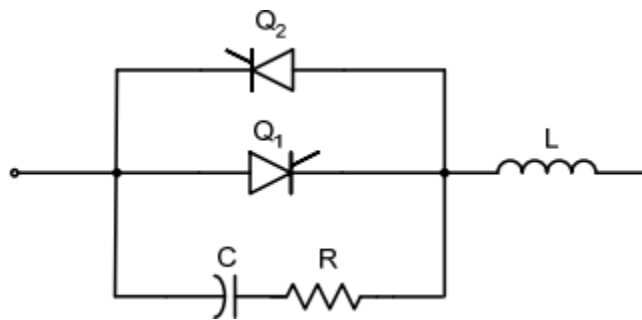

Figure: 1. 31. An un-polarized snubber circuit

An un-polarized snubber circuit is used when a pair of switching devices is used in anti-parallel. For determining the resistor and capacitor values a simple design technique can be used. For this an optimum design is needed. Hence a complex procedure will be used. These can be used to protect and thyristors.

Capacitors selection:

Snubber capacitors are subjected to high peak and RMS currents and high dv/dt . An example is turn-on and turn-off current spikes in a typical RCD snubber capacitor. The pulse will have high peak and RMS amplitudes. The snubber capacitor has to meet two requirements. First, the energy stored in the snubber capacitor must be greater than the energy in the circuit's inductance. Secondly, the time constant of snubber circuits should be small compared to shortest on time expected, usually 10% of the on time. By allowing the resistor to be effective in the ringing frequency this capacitor is used to minimize the

dissipation at switching frequency. The best design is selecting the impedance of the capacitor is same that of resistor at the ringing frequency.

Resistors selection:

It is important that R in the RC snubber, have low self inductance. Inductance in R will increase the peak voltage and it will tend to defeat the purpose of the snubber. Low inductance will also be desirable for R in snubber but it is not critical since the effect of a small amount of inductance is to slightly increase the reset time of C and it will reduce the peak current in switch at turn-on. The normal choice of R is usually the carbon composition or metal film. The resistor power dissipation must be independent of the resistance R because it dissipates the energy stored in the snubber capacitor in each transition of voltage in the capacitor. If we select the resistor as that the characteristic impedance, the ringing is well damped.

When comparing the Quick design to optimum design, the required snubber resistor’s power capability will be reduced. Usually the “Quick” design is completely adequate for final design. Going to the “Optimum” approach is only if power efficiency and size constraints dictate the need for optimum design.

Power Bipolar Junction Transistor (BJT)

Power BJT is used traditionally for many applications. However, IGBT (Insulated-Gate Bipolar Transistor) and MOSFET (Metal-Oxide-Semiconductor Field-Effect Transistor) have replaced it for most of the applications but still they are used in some areas due to its lower saturation voltage over the operating temperature range. IGBT and MOSFET have higher input capacitance as compared to BJT. Thus, in case of IGBT and MOSFET, drive circuit must be capable to charge and discharge the internal capacitances.

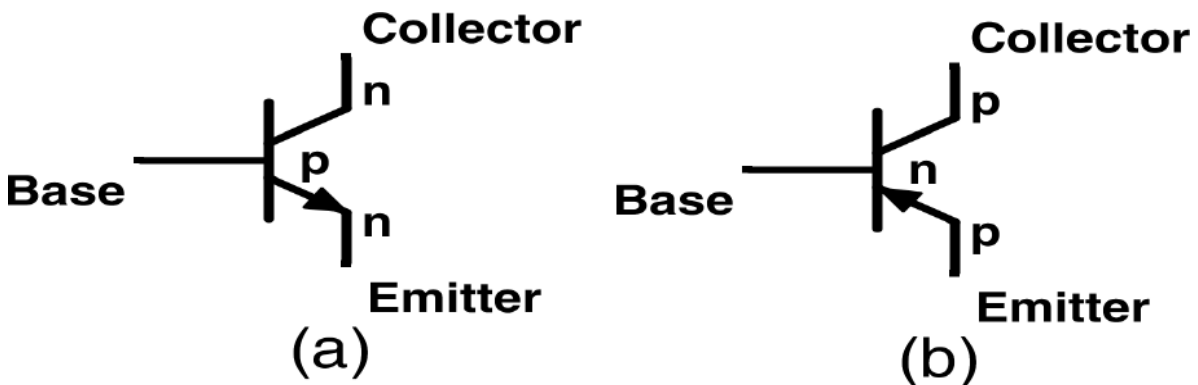

Figure: 1. 32. Symbol of transistor

The BJT is a three-layer and two-junction npn or pnp semiconductor device as given in Fig. 32. (a) and (b).

Although BJTs have lower input capacitance as compared to MOSFET or IGBT, BJTs are considerably slower in response due to low input impedance. BJTs use more silicon for the same drive performance.

In the case of MOSFET studied earlier, power BJT is different in configuration as compared to simple planar BJT. In planar BJT, collector and emitter is on the same side of the wafer while in power BJT it is on the opposite edges as shown in Fig. 33. This is done to increase the power-handling capability of BJT.

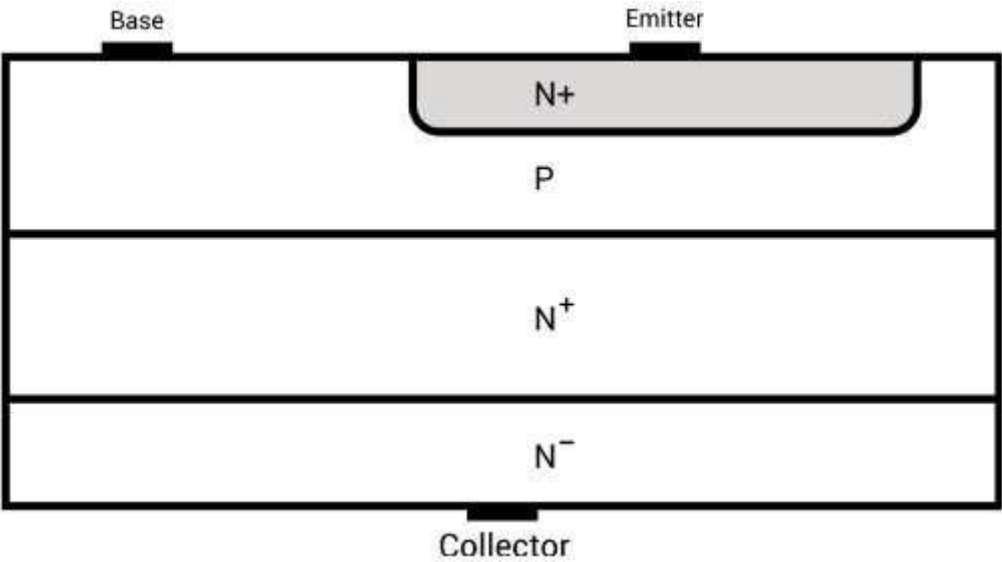

Figure: 1. 33. Structure of transistor

Power n-p-n transistors are widely used in high-voltage and high-current applications which will be discussed later.

Input and output characteristics of planar BJT for common-emitter configuration are shown in Fig. 34. These are current-voltage characteristics curves.

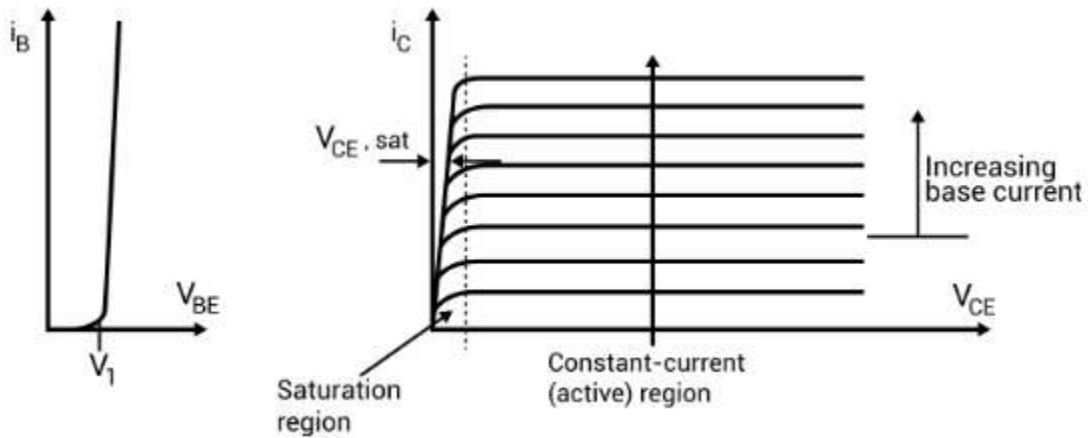

Figure: 1. 34. Input and output characteristics of BJT

Metal-Oxide Semiconductor Field-Effect Transistor (Power)

MOSFET is a voltage-controlled majority carrier (or unipolar) three-terminal device. As compared to the simple lateral channel MOSFET for low-power signals, power MOSFET has different structure. It has a vertical channel structure where the source and the drain are on the opposite side of the silicon wafer as shown in Figure. This opposite placement of the source and the drain increases the capability of the power MOSFET to handle larger power.

N-channel enhancement type MOSFET is more common due to high mobility of electrons.

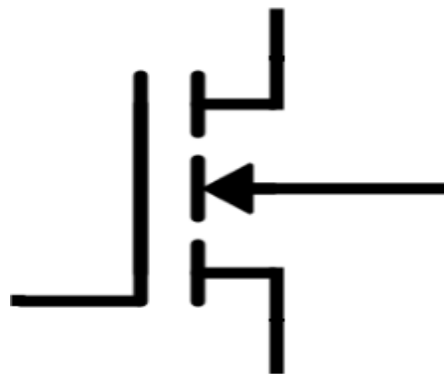

Figure: 1. 35. Symbol of MOSFET

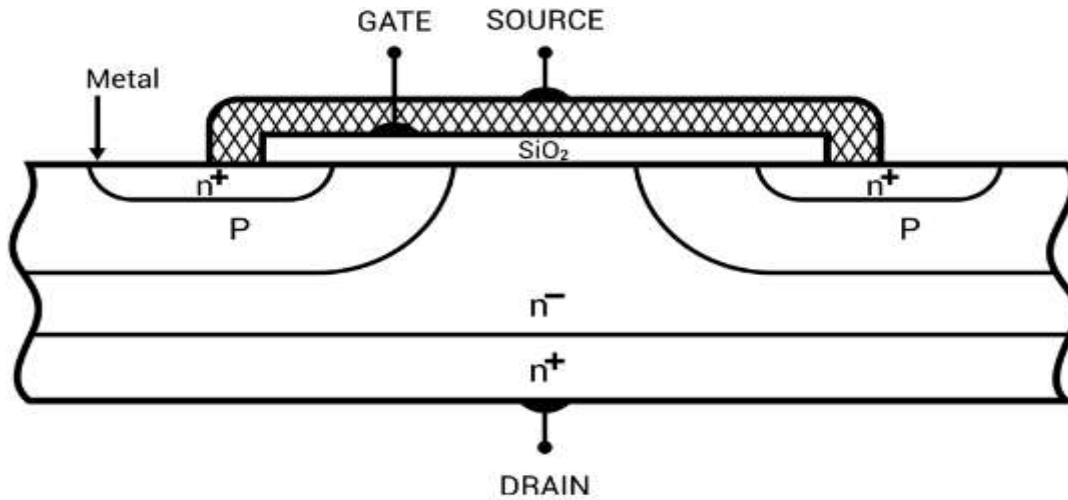

Figure: 1. 36. Structure of MOSFET

Basic circuit diagram and output characteristics of an n-channel enhancement power MOSFET with load connected are in Fig. 37 and Fig. 38 respectively.

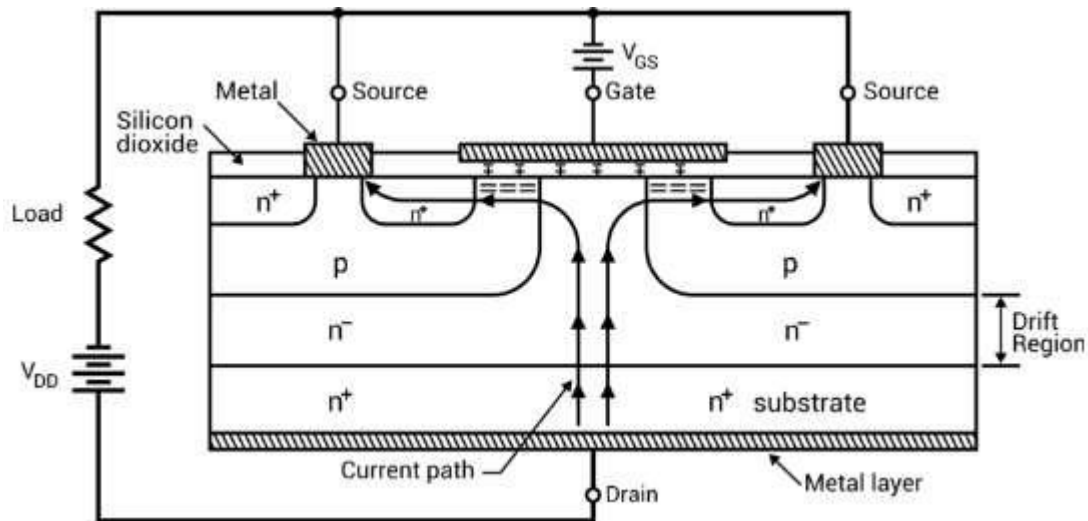

Figure: 1. 37. Basic circuit diagram of n-channel enhancement power MOSFET

Drift region shown in Fig. 37 determines the voltage-blocking capability of the MOSFET.

When $V_{GS} = 0$,

$\Rightarrow V_{DD}$ makes it reverse biased and no current flows from drain to source.

When $V_{GS} > 0$,

⇒ Electrons form the current path as shown in Fig. 37. Thus, current from the drain to the source flows. Now, if we will increase the gate-to-source voltage, drain current will also increase.

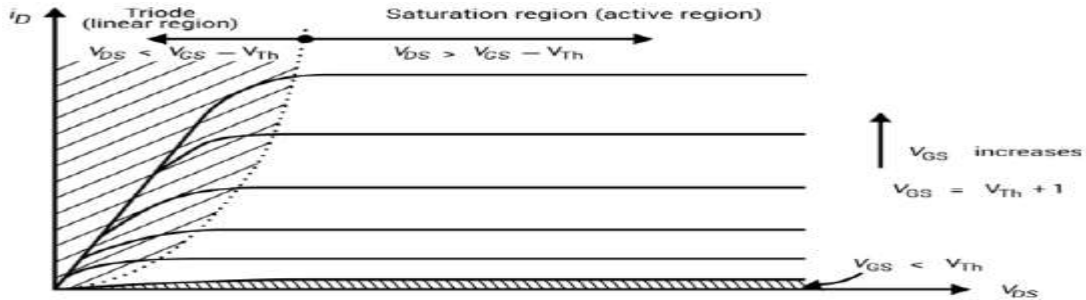

Figure: 1. 38. Output characteristics of an n-channel enhancement power MOSFET

For lower value of V_{DS} , MOSFET works in a linear region where it has a constant resistance equal to V_{DS} / I_D . For a fixed value of V_{GS} and greater than threshold voltage V_{TH} , MOSFET enters a saturation region where the value of the drain current has a fixed value.

Besides the output characteristics curves, transfer characteristics of power MOSFET is also shown in Fig. 39.

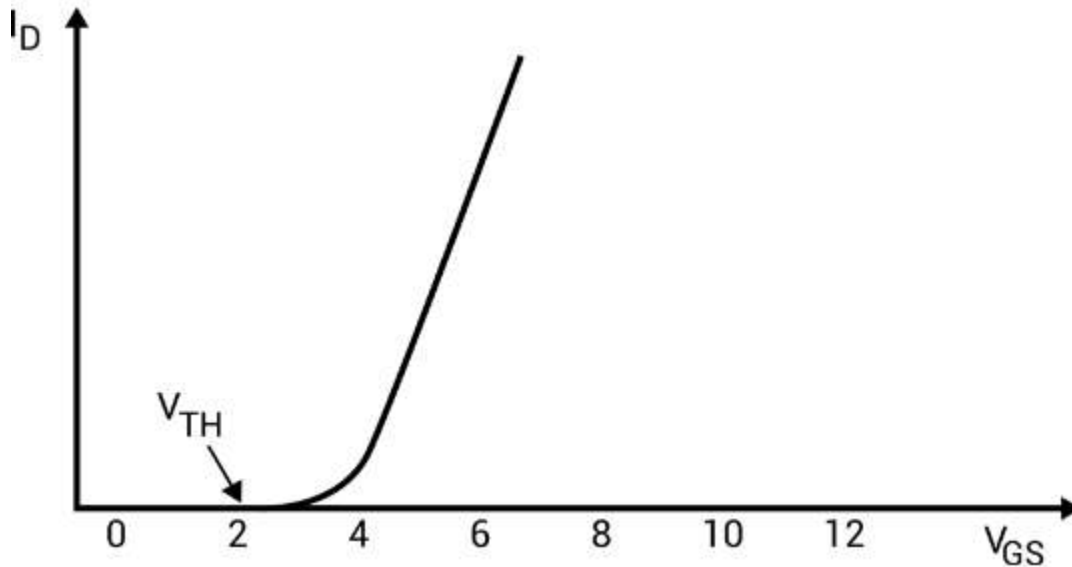

Figure: 1. 39. Transfer characteristics of an n-channel enhancement power MOSFET

Insulated-Gate Bipolar Transistor (IGBT)

IGBT combines the physics of both BJT and power MOSFET to gain the advantages of both worlds. It is controlled by the gate voltage. It has the high input impedance like a power MOSFET and has low on-state power loss as in case of BJT. There is no even secondary breakdown and not have long switching time as in case of BJT. It has better conduction characteristics as compared to MOSFET due to bipolar nature. It has no body diode as in case of MOSFET but this can be seen as an advantage to use external fast recovery diode for specific applications. They are replacing the MOSFET for most of the high voltage applications with less conduction losses. Its physical cross-sectional structural diagram and equivalent circuit diagram is presented in Fig. 40 to Fig. 41. It has three terminals called collector, emitter and gate.

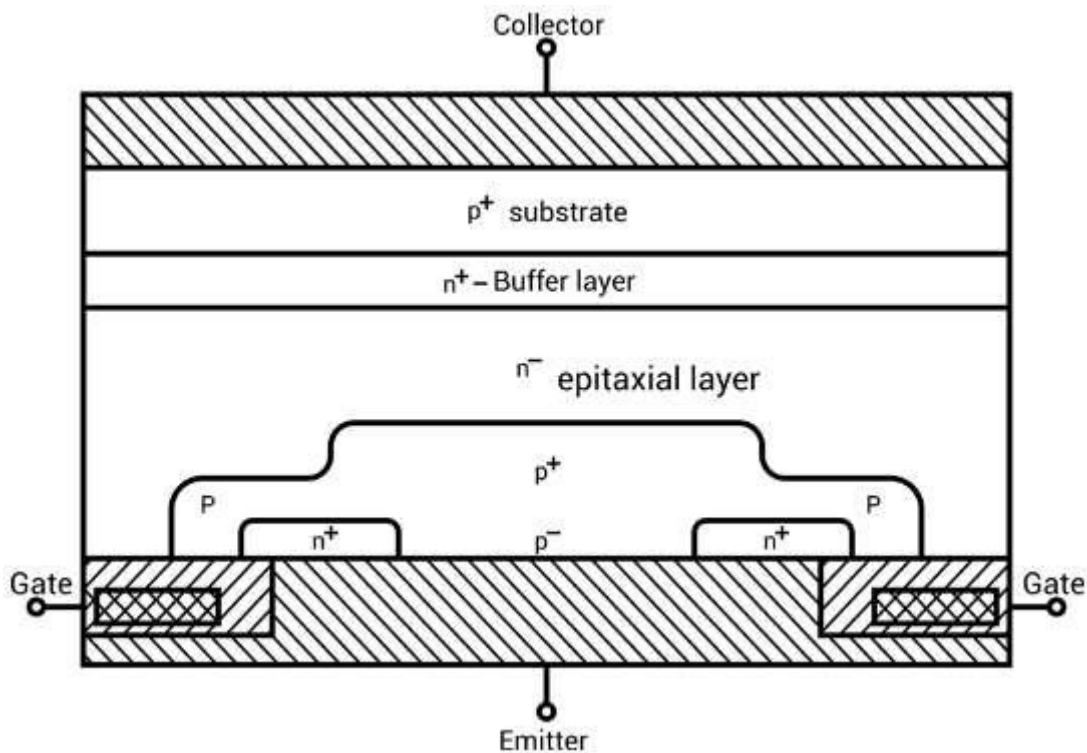

Figure: 1. 40. Cross -sectional structural diagram of IGBT

There is a p⁺ substrate which is not present in the MOSFET and responsible for the minority carrier injection into the n-region. Gain of NPN terminal is reduced due to wide epitaxial base and n⁺ buffer layer.

There are two structures of IGBTs based on doping of buffer layer:

a) Punch-through IGBT: Heavily doped n buffer layer \rightarrow less switching time

b) Non-Punch-through IGBT: Lightly doped n buffer layer \rightarrow greater carrier lifetime \rightarrow increased conductivity of drift region \rightarrow reduced on-state voltage drop

(Note: \rightarrow means implies)

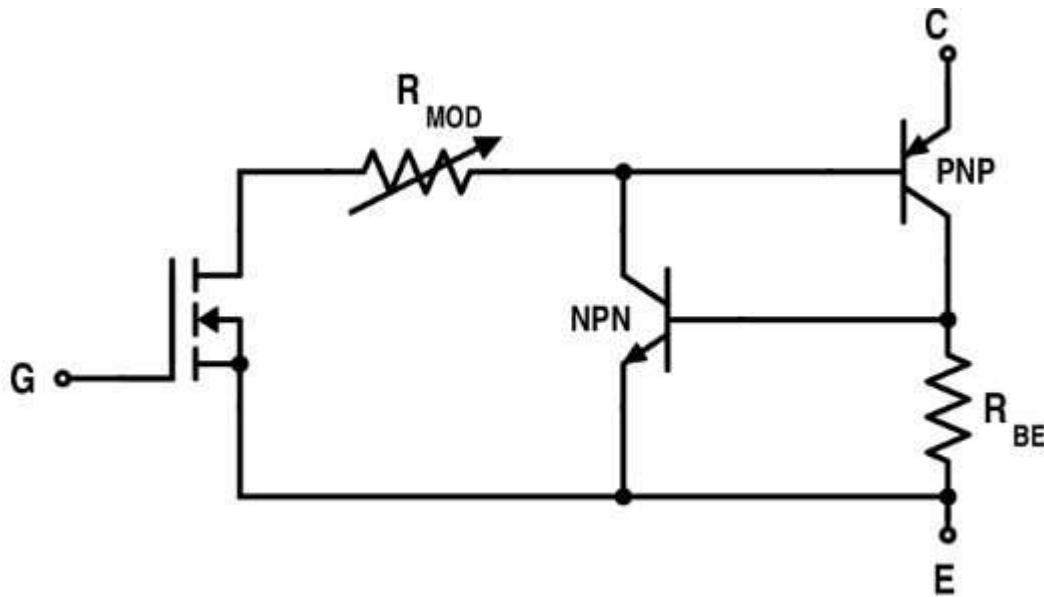

Figure: 1. 41. Equivalent diagram of IGBT

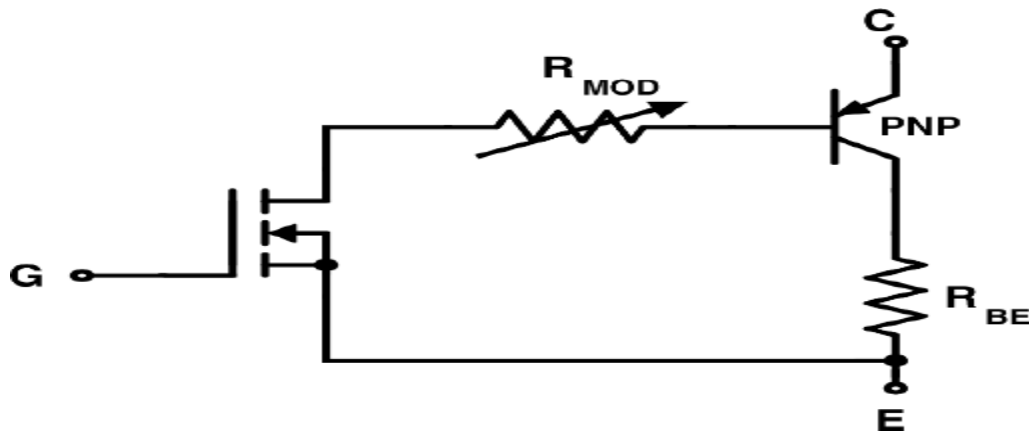

Figure: 1. 42. Simplified Equivalent diagram of IGBT

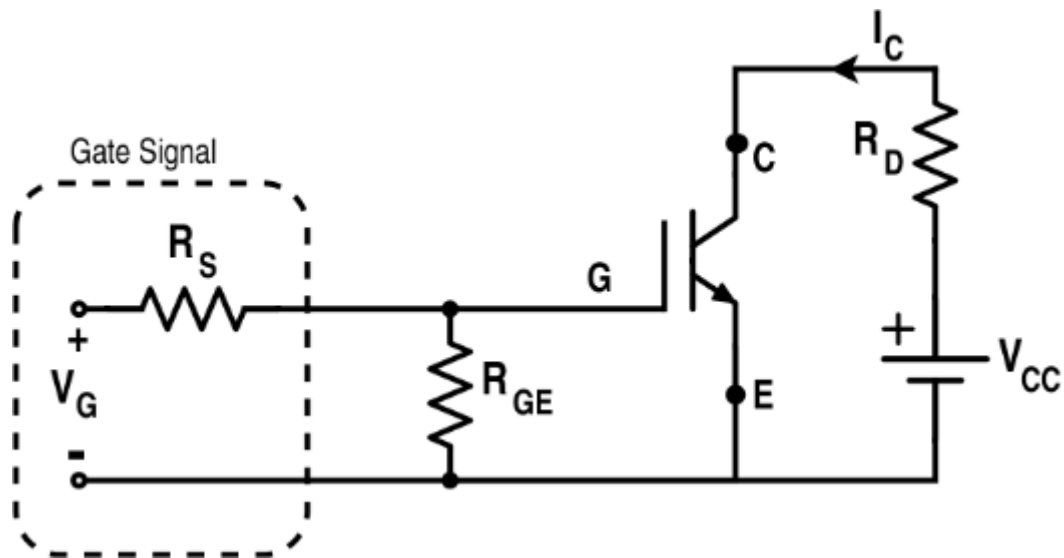

Figure: 43. Equivalent diagram of IGBT

Based on this circuit diagram given in Fig. 43, forward characteristics and transfer characteristics are obtained which are given in Fig. 44 and Fig. 45. Its switching characteristic is also shown in Fig. 45.

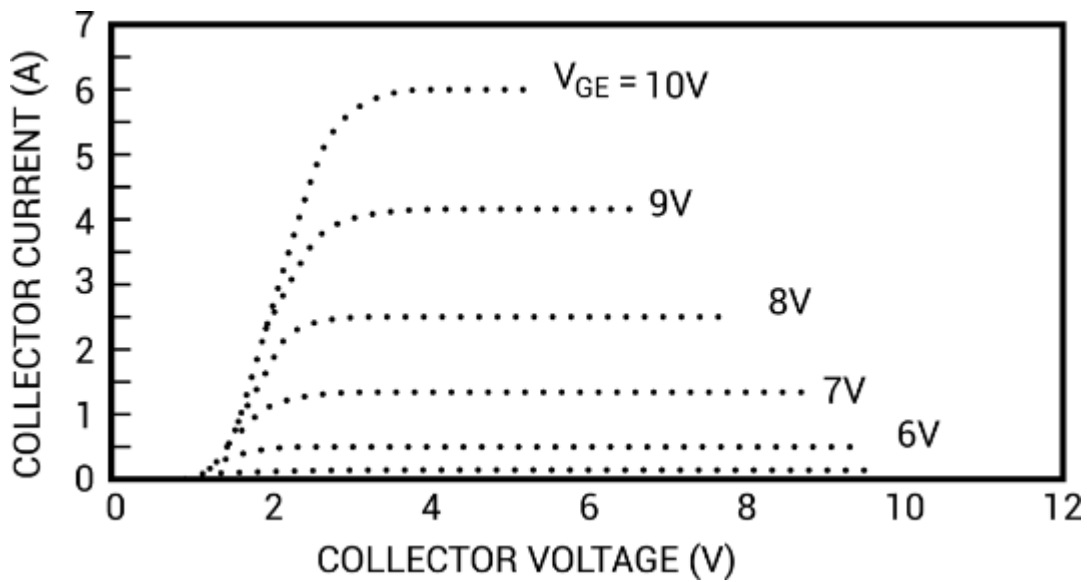

Figure: 1. 44. Forward characteristics of IGBT

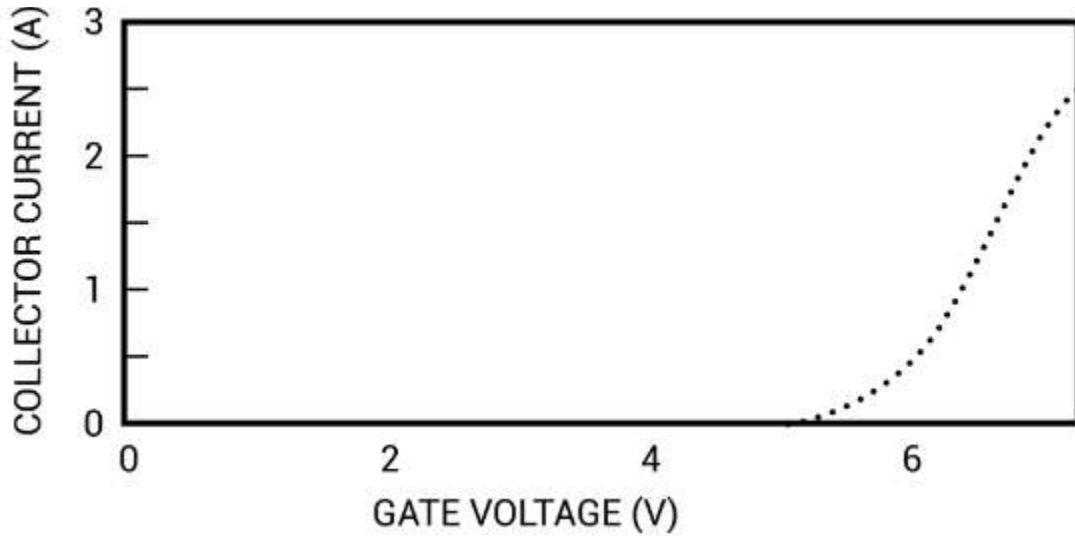

Figure: 1.45. Transfer characteristics of IGBT

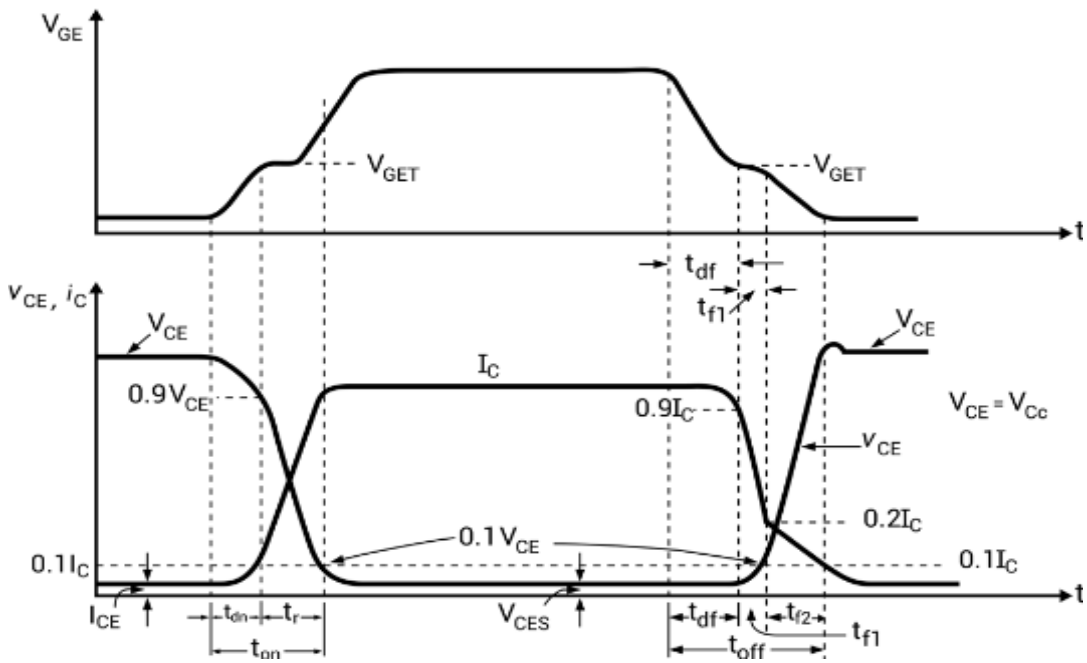

Figure: 1.46. Dynamic characteristics of IGBT

(Note: T_{dn} : delay time ; T_r : rise time ; T_{df} : delay time ; T_{f1} : initial fall time ; T_{f2} : final fall time)

GTO (Gate Turn-off Thyristor)

GTO can be turned on with the positive gate current pulse and turned off with the negative gate current pulse. Its capability to turn off is due to the diversion of PNP collector current by the gate and thus breaking the regenerative feedback effect.

Actually the design of GTO is made in such a way that the pnp current gain of GTO is reduced. A highly doped n spot in the anode p layer form a shorted emitter effect and ultimately decreases the current gain of GTO for lower current regeneration and also the reverse voltage blocking capability. This reduction in reverse blocking capability can be improved by diffusing gold but this reduces the carrier lifetime. Moreover, it requires a special protection.

The symbol for GTO is shown in Fig.46.

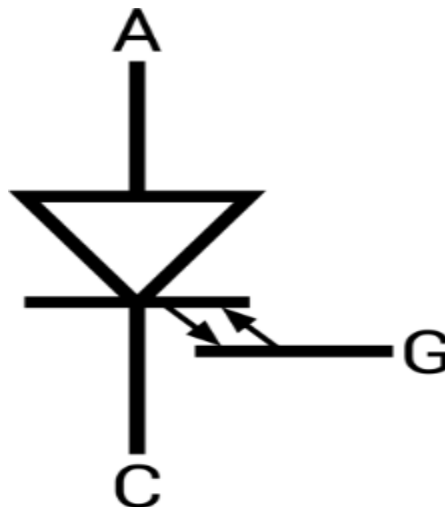

Figure: 1. 47. Symbol of GTO

Overall switching speed of GTO is faster than thyristor (SCR) but voltage drop of GTO is larger. The power range of GTO is better than BJT, IGBT or SCR.

The static voltage current characteristics of GTO are similar to SCR except that the latching current of GTO is larger (about 2 A) as compared to SCR (around 100-500 mA).

The gate drive circuitry with switching characteristics is given in Fig. 48 and Fig. 49.

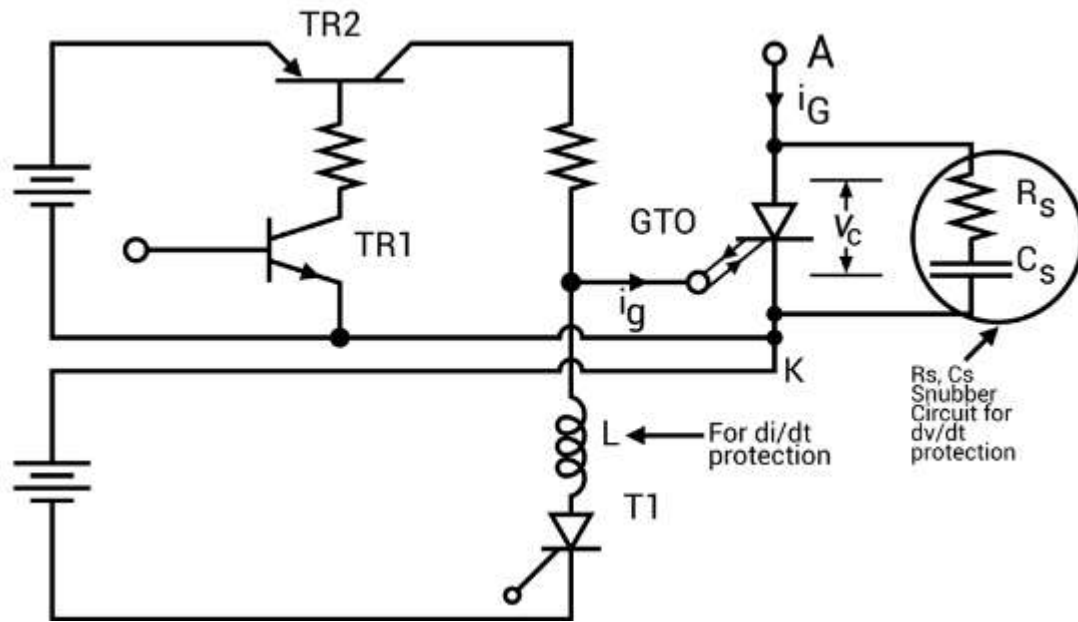

Figure: 1. 48. Gate Drive Circuit for GTO

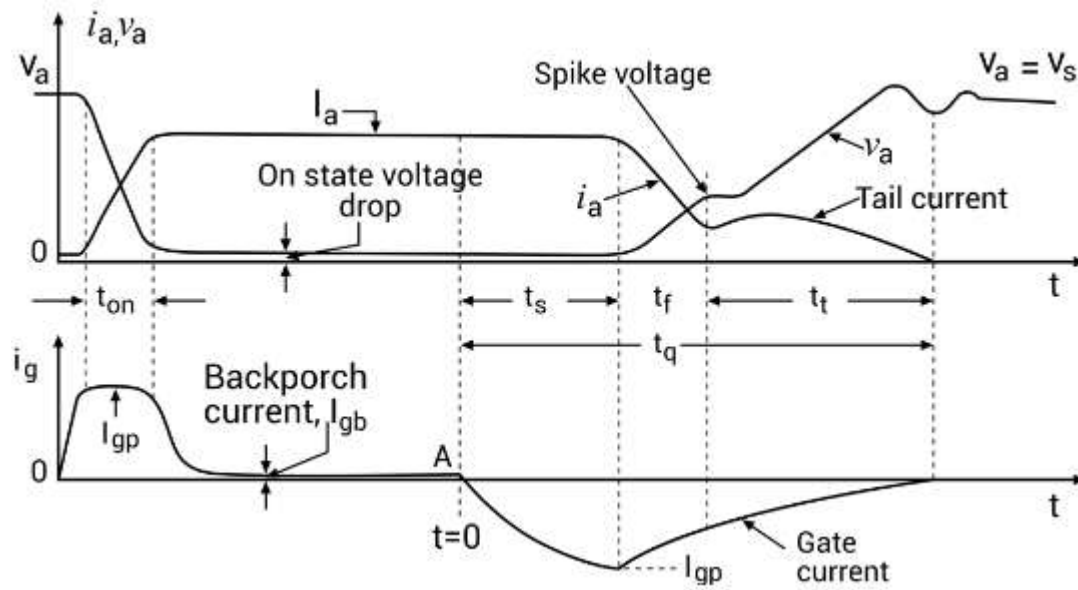

Figure: 1. 49. Switching characteristics for GTO

SCR Specifications and Ratings:

The main specifications of the SCR are its voltage rating and current rating. In this post, let us see various ratings of thyristor.

Voltage Ratings

Peak Inverse Voltage (V_{PIV})

The peak inverse voltage is defined as the maximum voltage which SCR can safely withstand in its OFF state. The applied voltage should never be exceeded under any circumstances.

On State Voltage:

The voltage which appears across the SCR during its ON state is known as its ON state Voltage. The maximum value of voltage which can appear across the SCR during its conducting state is called its maximum on state voltage. Usually it will be 1V to 4V.

Finger Voltage:

The minimum voltage, which is required between the anode and cathode of an SCR to trigger it to conduction mode, is called its finger voltage.

Rate of Rise of Voltage (dV/dt)

The rate at which the voltage across the device rises (for forward condition) without triggering the device, is known as its rate of rise of voltage.

Voltage Safety Factor:

The normal operating voltage of the SCR is kept well below its peak inverse voltage(V_{PIV}) to avoid puncture of SCR due to uncertain conditions. The operating voltage and peak inverse voltage are related by voltage safety factor V_f

$$V_f = \text{Peak inverse voltage} / (2 \times \text{RMS value of input voltage})$$

Normally V_f value lies between 2 and 2.5

Current Ratings:

The current carrying capacity of the device is known as its current rating.

It can be of two types.

1. Continuous
2. Intermittent.

Maximum average ON state current (I_{mac}):

This is the average value of maximum continuous sinusoidal ON state current with conduction angle 180deg, at frequency 40 to 60Hz, which should not be exceeded even with intensive cooling.

Maximum rms ON-state current: (I_{mrc})

It is the rms value of the maximum continuous sinusoidal ON state current at the frequency 40 to 60 Hz and conduction angle 180deg, which should not be exceeded even with intensive cooling.

Maximum surge - ON state Current (I_{msc})

It is the maximum admissible peak value of a sinusoidal half cycle of ten milliseconds duration at a frequency of 50Hz.

Latching Current (I_l)

It is the minimum current, which is required to latch the device from its OFF state to its ON state. In other words, it is the minimum current required to trigger the device.

Holding Current (I_H)

It is the minimum current required to hold the SCR conducting. In other words, It is the minimum current, below which the device stops conducting and returns to its OFF state.

Gate Current:

The current which is applied to the gate of the device for control purposes is known as gate current.

Minimum Gate Current:

The minimum current required at the gate for triggering the device.

Maximum Gate Current:

The maximum current which can be applied to device safely. Current higher than this will damage the gate terminal.

Gate Power Loss:

The mean power loss, which occurs due to flow of gate current between the gate and the main terminals.

Turn ON time:

The time taken by the device before getting latched from its OFF state to ON state. In other words, it is the time for which the device waits before achieving its full conduction. Usually it will be 150 to 200 μ sec.

Turn OFF time:

After applying reverse voltage, the device takes a finite time to get switched OFF. This time is called as turn-OFF time of the device. Usually it will be 200 μ sec.

Rate of rise of current (dI/dt)

The rate at which the current flowing in the device rises is known as its rate of rise (dI/dt) of current.

Comparison between BJT and MOSFET:

Sl No	BJT	MOSFET
1	It is a Bipolar Device	It is majority carrier Device
2	Current control Device	Voltage control Device.
3	Output is controlled by controlling base current	Output is controlled by controlling gate voltage
4	Negative temperature coefficient	Positive temperature coefficient
5	So paralleling of BJT is difficult.	So paralleling of this device is easy.
6	Dive circuit is complex. It should provide constant current(Base current)	Dive circuit is simple. It should provide constant voltage(gate voltage)
7	Losses are low.	Losses are higher than BJTs.
8	So used in high power applications.	Used in low power applications.
9	BJTs have high voltage and current ratings.	They have less voltage and current ratings.
10	Switching frequency is lower than MOSFET.	Switching frequency is high.