



SNS COLLEGE OF ENGINEERING

Kurumbapalayam(Po), Coimbatore - 641 107

Accredited by NAAC-UGC with 'A' Grade

Approved by AICTE, Recognized by UGC & Affiliated to Anna University, Chennai

Department of Information Technology

Course Name - 19IT401 Computer Networks

II Year / IV Semester

Unit 1 - Introduction and Physical Layer

Topic 6- Physical Medium

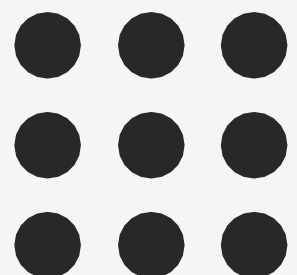

Physical Medium

- Physical media provide the connections between network devices that make networking possible.

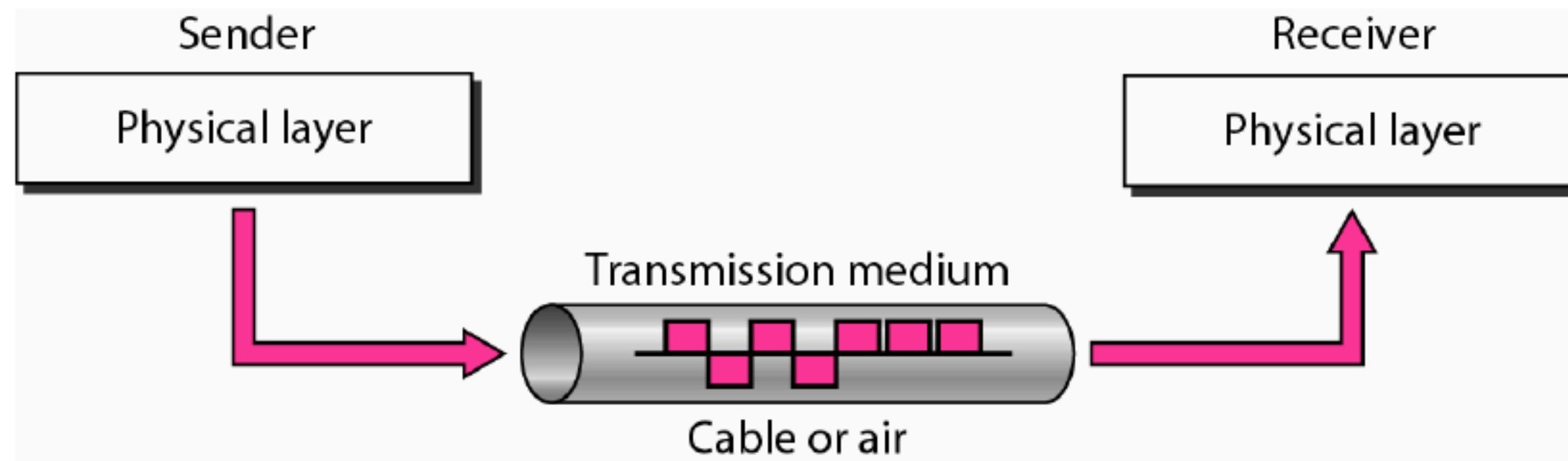

- A transmission medium can be broadly defined as anything that can carry information from a source to a destination

Physical Medium

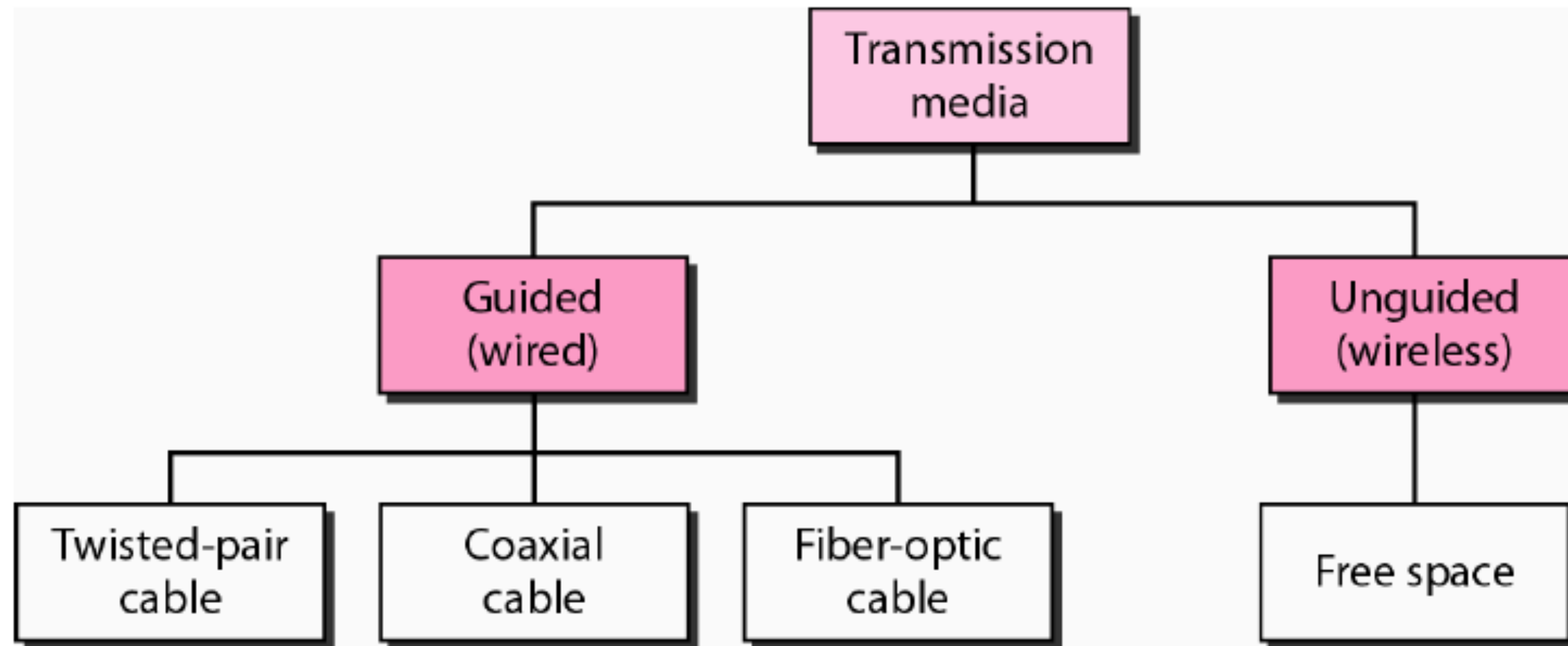

Physical Medium

- Guided media, which are those that provide a conduit from one device to another, include twisted-pair cable, coaxial cable, and fiber-optic cable.

Twisted Pair

- A twisted pair consists of two conductors (normally copper), each with its own plastic insulation, twisted together.

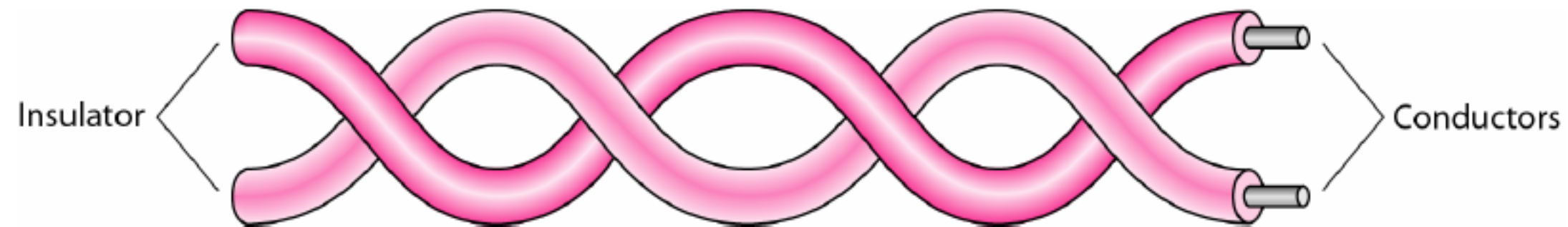

- One of the wires is used to carry signals to the receiver, and the other is used only as a ground reference

Physical Medium

Types of Twisted Pair

- Unshielded twisted-pair (UTP)
- Shielded twisted-pair (STP) (IBM)
- STP cable has a metal foil or braided mesh covering that encases each pair of insulated conductors. Although metal casing improves the quality of cable by preventing the penetration of noise or crosstalk, it is bulkier and more expensive.

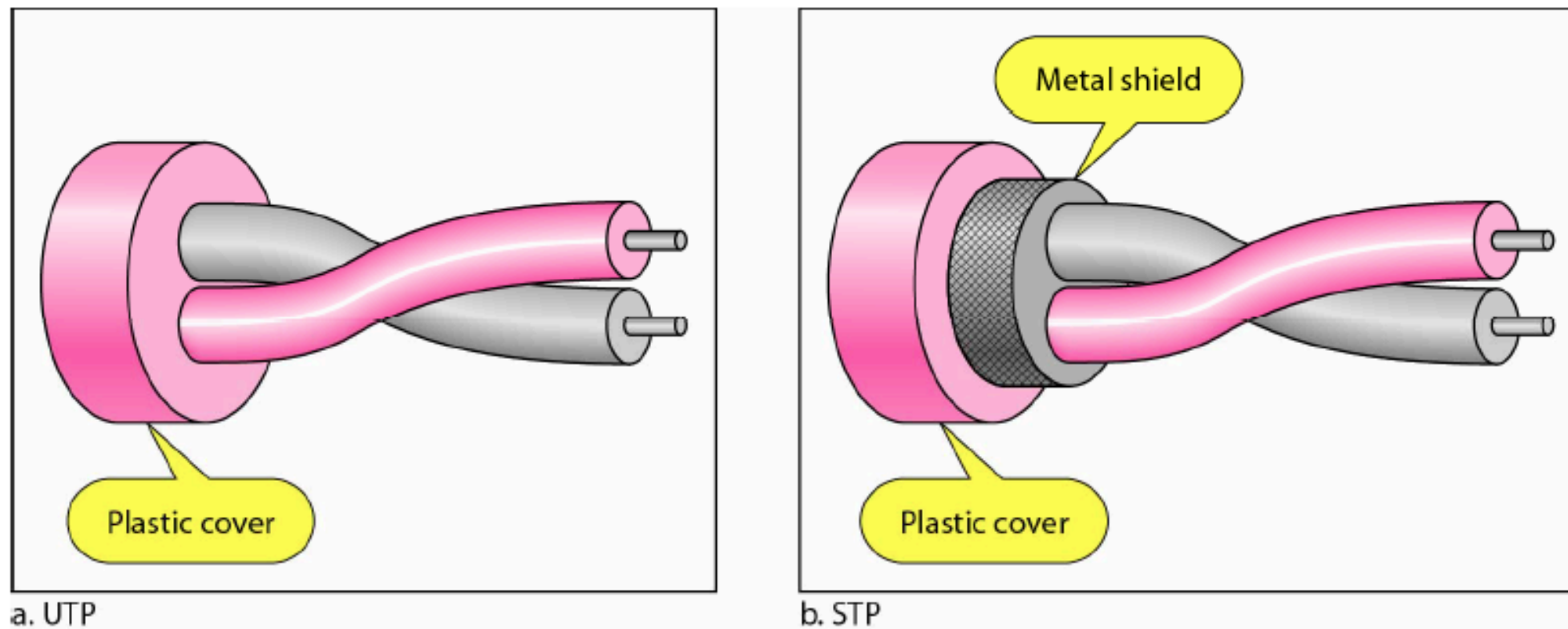

Typical Usage of Twisted Pair

Name	Type	Mbps	m	In...
Cat 1	UTP	1	90	
Cat 2	UTP	4	90	Tkn Ring/Phone
Cat 3	UTP	10	100	10BaseT
Cat 4	STP	16	100	TRing 16
Cat 5	S/UTP	100	200	100BaseT

Physical Medium

Pros and Cons

- Cheap
- Easy to work with
 - Can use as digital or analog
- Limited bandwidth/data rate
 - Generally 1Mhz and 100Mbps
- Short range
 - 2km for digital, 5km for analog
- Direct relationship between data rate and range
 - Gigabit Ethernet
 - 1000Mbps over 4 Cat5 UTP up to 100 meters
 - IEEE 802.3ab standard in 1999
 - 1000Mbps over 1 Cat5 UTP up to 24 meters

Unshielded Twisted Pair (UTP)

- Ordinary telephone wire
- Cheapest
- Easiest to install
- Suffers from external EM interference

Shielded Twisted Pair (STP)

- Metal braid or sheathing that reduces interference
- More expensive
- Harder to handle (thick, heavy)

Physical Medium

Connectors

The most common UTP connector is RJ45 (RJ stands for registered jack)

The RJ45 is a keyed connector, meaning the connector can be inserted in only one way.

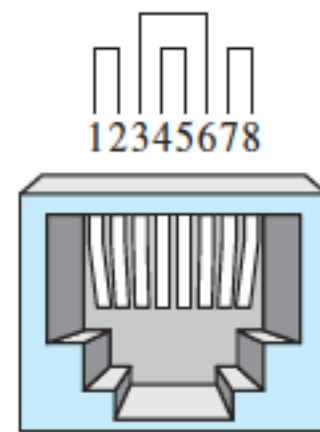

RJ-45 Female

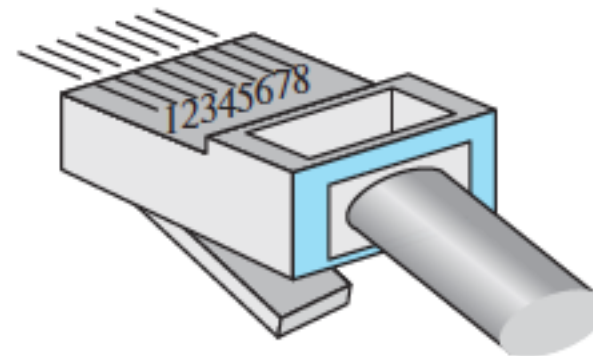

RJ-45 Male

Physical Medium

Coaxial cable

- Coaxial cable (or coax) carries signals of higher frequency ranges than those in twisted pair cable, in part because the two media are constructed quite differently.
- Instead of having two wires, coax has a central core conductor of solid or stranded wire (usually copper) enclosed in an insulating sheath, which is, in turn, encased in an outer conductor of metal foil, braid, or a combination of the two.
- The outer metallic wrapping serves both as a shield against noise and as the second conductor, which completes the circuit.

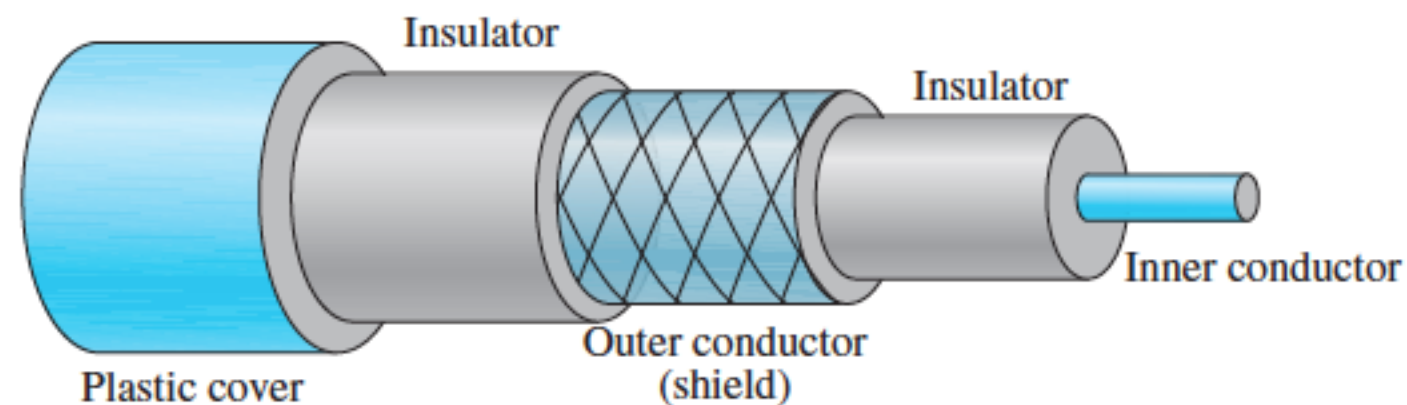

Physical Medium

Coaxial cable

Coaxial Cable Standards Coaxial cables are categorized by their Radio Government (RG) ratings.

<i>Category</i>	<i>Impedance</i>	<i>Use</i>
RG-59	75 Ω	Cable TV
RG-58	50 Ω	Thin Ethernet
RG-11	50 Ω	Thick Ethernet

Coaxial Cable Connectors

The most common type of connector used today is the Bayonet Neill-Concelman (BNC) connector.

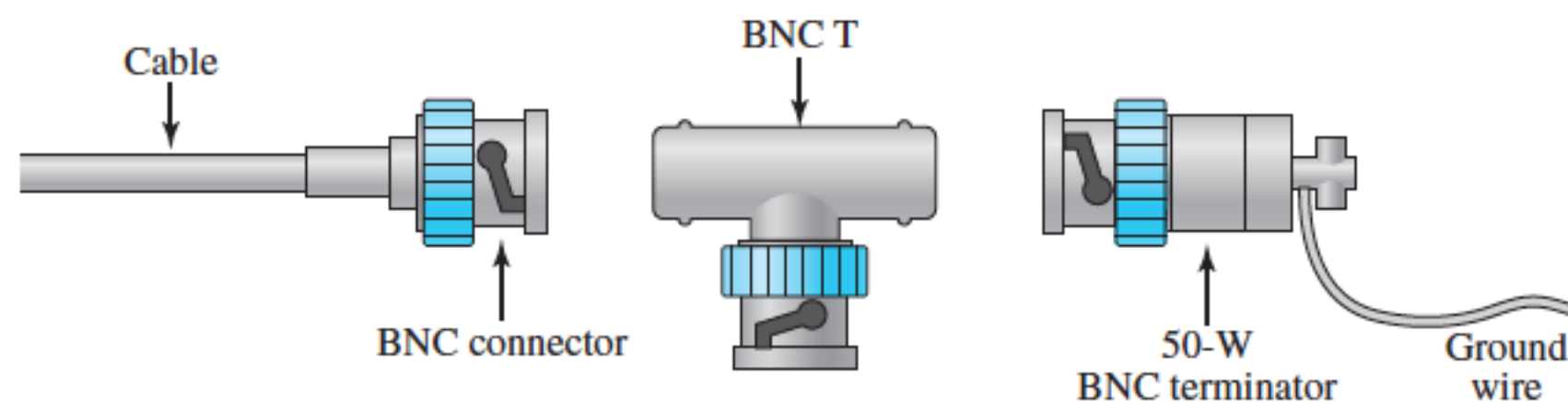



Physical Medium



Applications

- Cable TV networks. Cable TV uses RG-59 coaxial cable.
- Ethernet LANs
- The 10Base-2, or Thin Ethernet, uses RG-58 coaxial cable with BNC connectors to transmit data at 10 Mbps with a range of 185 m.
- The 10Base5, or Thick Ethernet, uses RG-11 (thick coaxial cable) to transmit 10 Mbps with a range of 5000 m.



Physical Medium

Fiber-Optic Cable

- A fiber-optic cable is made of glass or plastic and transmits signals in the form of light.
- It transmits light rather than electronic signals
- It is the standard for connecting networks between buildings, due to its immunity to the effects of moisture and light
- Fiber optic cable has the ability to transmit signals over much longer distances than coaxial or twisted pair
- It can also carry information at vastly greater speeds
- Fiber optic cable is more difficult to install than other cabling

Physical Medium

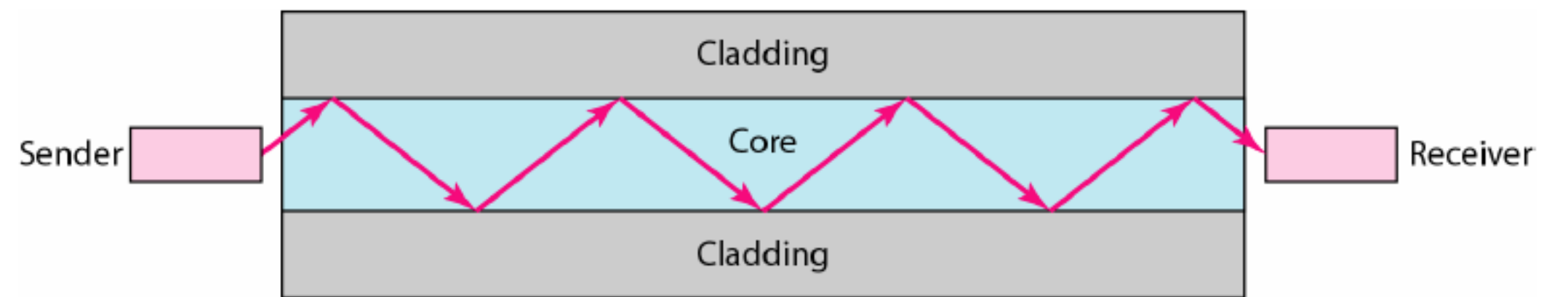
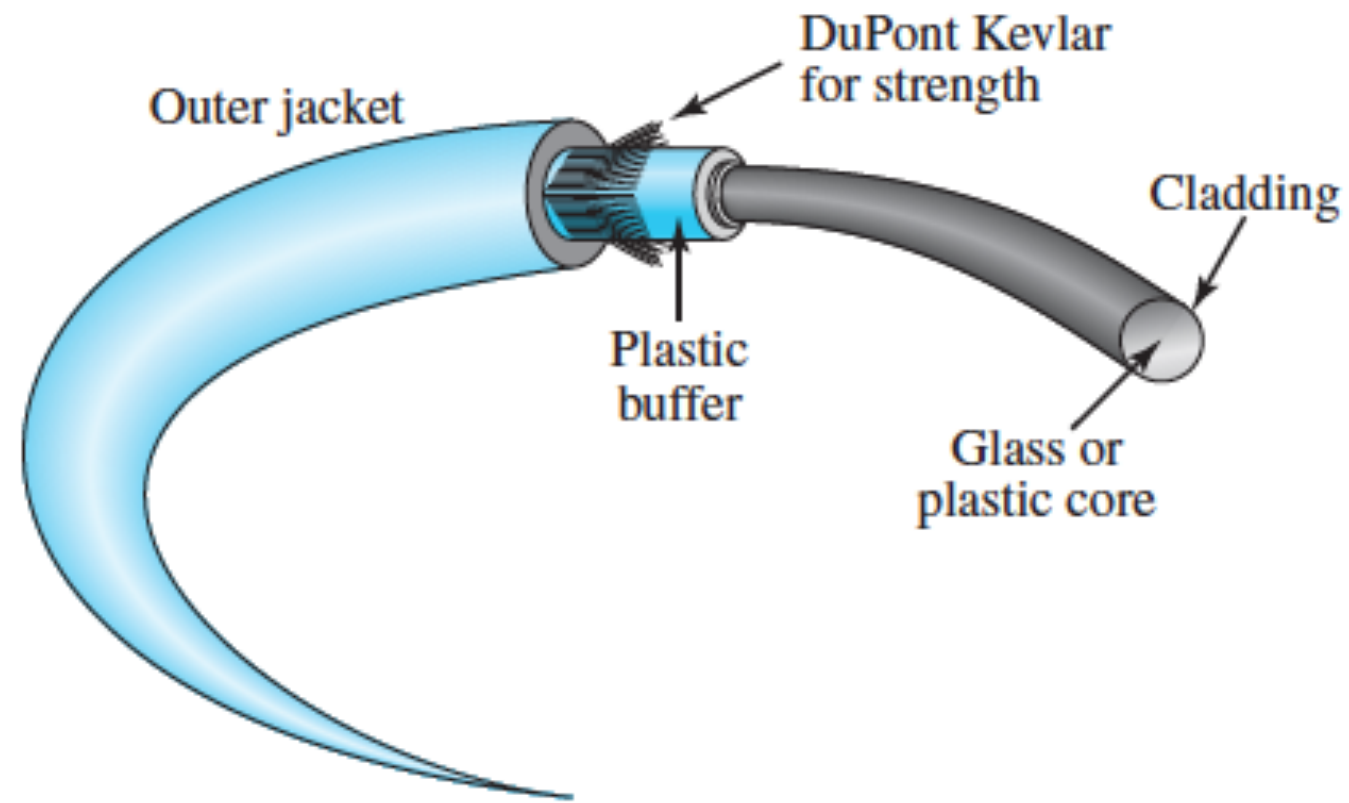

Physical Medium

Fiber-Optic Cable Connectors

- There are three types of connectors for fiber-optic cables,
- The subscriber channel (SC) connector is used for cable TV. It uses a push/pull locking system.
- The straight-tip (ST) connector is used for connecting cable to networking devices. It uses a bayonet locking system and is more reliable than SC.
- MT-RJ is a connector that is the same size as RJ45.

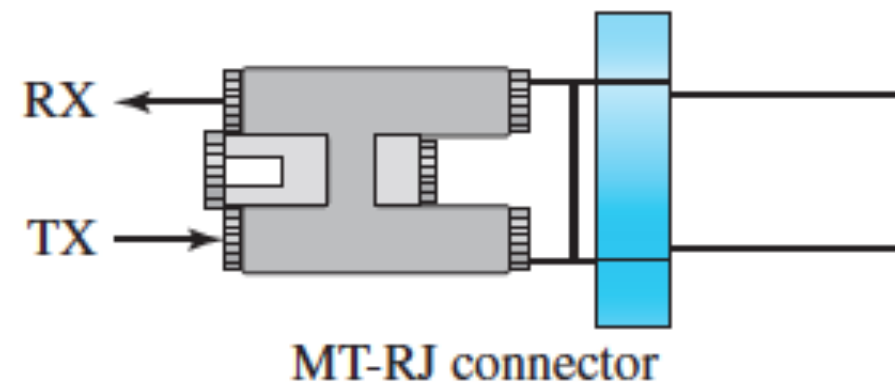
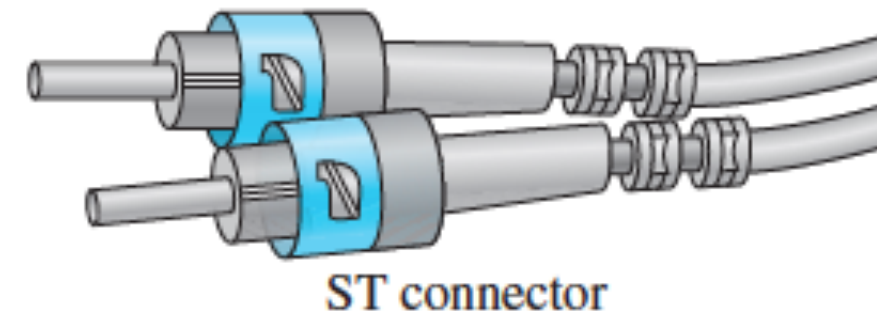
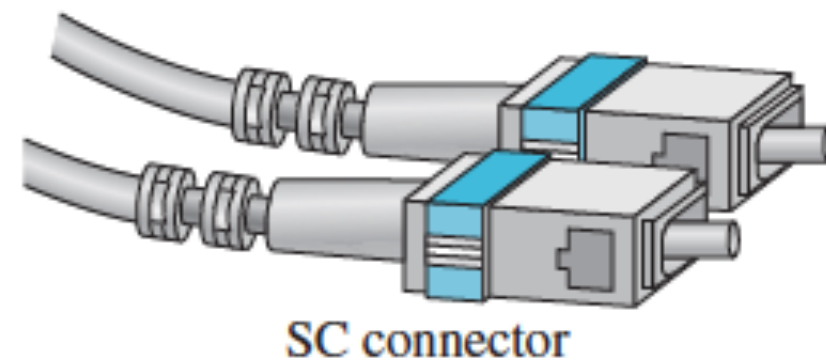

Physical Medium

Propagation Modes

- Current technology supports two modes (multimode and single mode) for propagating light along optical channels.
- Multimode can be implemented in two forms: step-index or graded-index

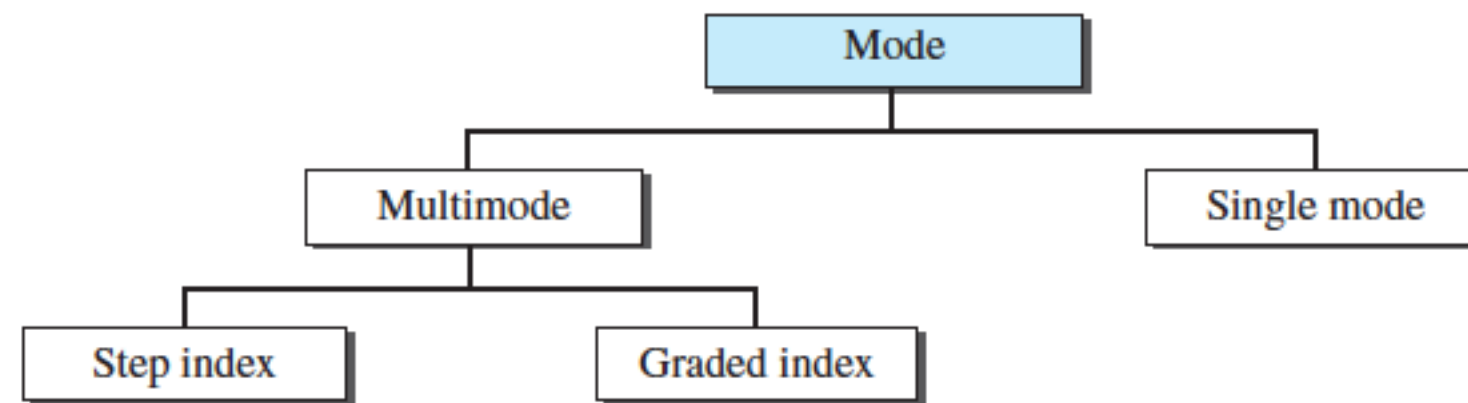

Multimode

Multimode is so named because multiple beams from a light source move through the core in different paths.

Physical Medium

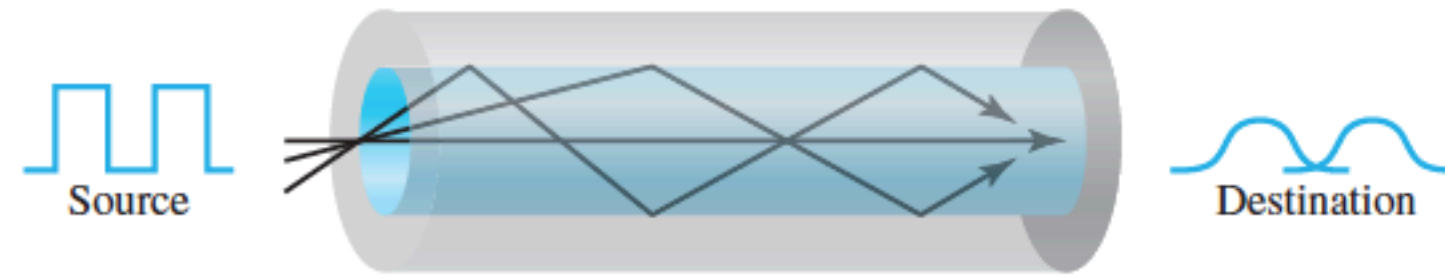

a. Multimode, step index

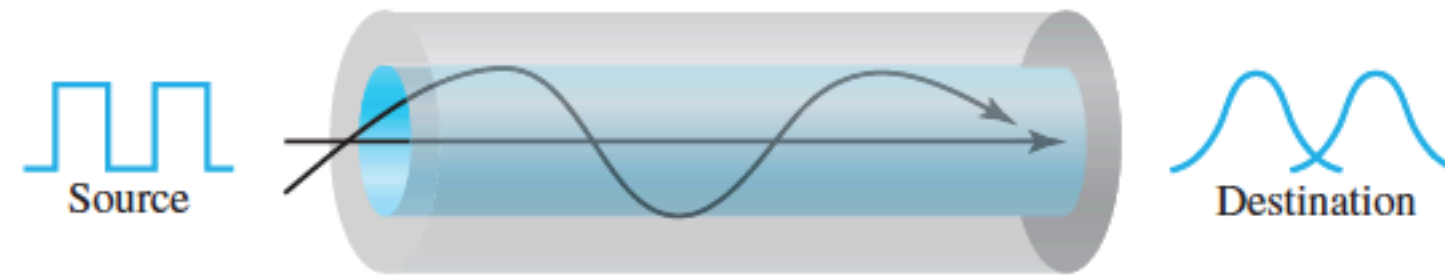

b. Multimode, graded index



c. Single mode



Physical Medium



Fiber Types.

<i>Type</i>	<i>Core (μm)</i>	<i>Cladding (μm)</i>	<i>Mode</i>
50/125	50.0	125	Multimode, graded index
62.5/125	62.5	125	Multimode, graded index
100/125	100.0	125	Multimode, graded index
7/125	7.0	125	Single mode

Physical Medium

UNGUIDED MEDIA: WIRELESS

- Unguided medium transport electromagnetic waves without using a physical conductor.
- This type of communication is often referred to as wireless communication .
- Signals are normally broadcast through free space and thus are available to anyone who has a device capable of receiving them.
- Electromagnetic spectrum, ranging from 3 kHz to 900 THz, used for wireless communication.
- Unguided signals can travel from the source to the destination in several ways: ground propagation, sky propagation, and line-of-sight propagation

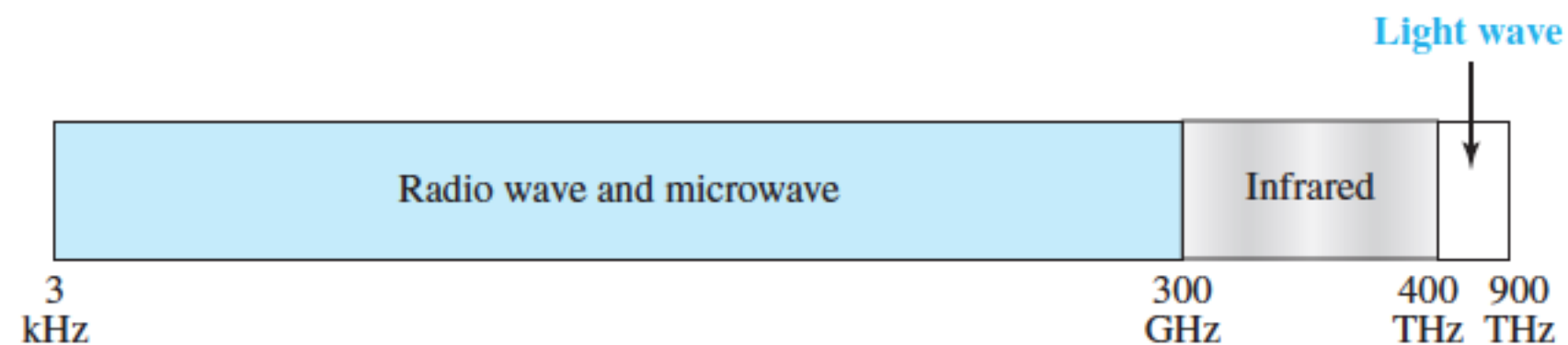

Physical Medium

Propagation Mode

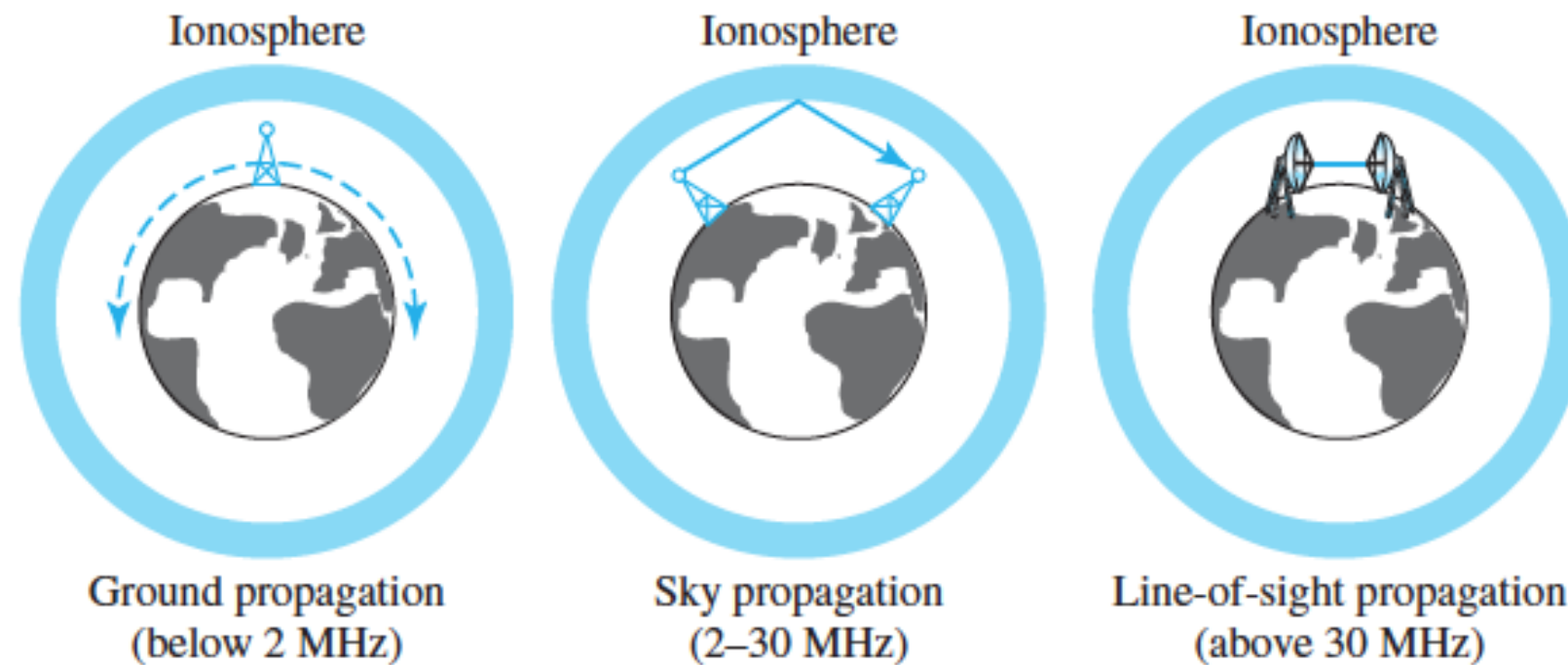

- In ground propagation, radio waves travel through the lowest portion of the atmosphere, hugging the earth.
- In sky propagation, higher-frequency radio waves radiate upward into the ionosphere (the layer of atmosphere where particles exist as ions) where they are reflected back to earth
- In line-of-sight propagation, very high-frequency signals are transmitted in straight lines directly from antenna to antenna

Physical Medium

Bands

<i>Band</i>	<i>Range</i>	<i>Propagation</i>	<i>Application</i>
very low frequency (VLF)	3–30 kHz	Ground	Long-range radio navigation
low frequency (LF)	30–300 kHz	Ground	Radio beacons and navigational locators

<i>Band</i>	<i>Range</i>	<i>Propagation</i>	<i>Application</i>
middle frequency (MF)	300 kHz–3 MHz	Sky	AM radio
high frequency (HF)	3–30 MHz	Sky	Citizens band (CB), ship/aircraft
very high frequency (VHF)	30–300 MHz	Sky and line-of-sight	VHF TV, FM radio
ultrahigh frequency (UHF)	300 MHz–3 GHz	Line-of-sight	UHF TV, cellular phones, paging, satellite
superhigh frequency (SHF)	3–30 GHz	Line-of-sight	Satellite
extremely high frequency (EHF)	30–300 GHz	Line-of-sight	Radar, satellite



Physical Medium



Types

Radio waves,
Microwaves, and
Infrared waves.

Radio Wave

- Although there is no clear-cut demarcation between radio waves and microwaves, electromagnetic waves ranging in frequencies between 3 kHz and 1 GHz are normally called radio waves;
- Waves ranging in frequencies between 1 and 300 GHz are called microwaves.
- Radio waves, for the most part, are omnidirectional. When an antenna transmits radio waves, they are propagated in all directions.
- This means that the sending and receiving antennas do not have to be aligned.
- Radio waves, particularly those waves that propagate in the sky mode, can travel long distances. This makes radio waves a good candidate for long-distance broadcasting such as AM radio.



Physical Medium

Applications

The omnidirectional characteristics of radio waves make them useful for multicasting, in which there is one sender but many receivers.

AM and FM radio, television, maritime radio, cordless phones, and paging are examples of multicasting.

Disadvantage

Interference

The radio waves transmitted by one antenna are susceptible to interference by another antenna that may send signals using the same frequency or band.



Physical Medium

Microwaves

Electromagnetic waves having frequencies between 1 and 300 GHz are called microwaves.

Microwaves are unidirectional. When an antenna transmits microwaves, they can be narrowly focused.

This means that the sending and receiving antennas need to be aligned.

Microwave propagation is line-of-sight. Since the towers with the mounted antennas need to be in direct sight of each other, towers that are far apart need to be very tall.

Microwaves are used for unicast communication such as cellular telephones, satellite networks, and wireless LANs.



Physical Medium

Infrared

- Infrared waves, with frequencies from 300 GHz to 400 THz (wavelengths from 1 mm to 770 nm), can be used for short-range communication.
- Infrared waves, having high frequencies, cannot penetrate walls.
- This advantageous characteristic prevents interference between one system and another; a short-range communication system in one room cannot be affected by another system in the next room.
- However, infrared signals are useless for long-range communication.
- In addition, we cannot use infrared waves outside a building because the sun's rays contain infrared waves that can interfere with the communication.



Physical Medium



Application

The Infrared Data Association (IrDA), an association for sponsoring the use of infrared waves, has established standards for using these signals for communication between devices such as keyboards, mice, PCs, and printers