



SNS COLLEGE OF ENGINEERING

Kurumbapalayam (Po), Coimbatore – 641 107

An Autonomous Institution

Accredited by NBA – AICTE and Accredited by NAAC – UGC with 'A' Grade

Approved by AICTE, New Delhi & Affiliated to Anna University, Chennai

DEPARTMENT OF ELECTRICAL AND ELECTRONICS ENGINEERING

COURSE NAME : 190E120 AUTOMOTIVE ELECTRONICS

I YEAR /I SEMESTER MECHATRONICS ENGINEERING

**Unit 4 – ELECTRONIC FUEL INJECTION, IGNITION SYSTEMS AND
DIGITAL ENGINE CONTROL SYSTEM**



ELECTRONIC IGNITION SYSTEM



❑ **Electronic Ignition System:**

- Modern day vehicles use electronic ignition system instead of conventional ignition systems described above due to large number of advantages.
- With the advances in solid state devices (semi-conductor and chips technology) over last few decades, modifications were done to conventional ignition system using transistor technologies.

❑ **Need of Electronic Ignition System (Limitations of Conventional Ignition System)**

- Conventional ignition systems have following limitations.
 - Lower spark voltage at higher speeds
 - Lower MTBF (Mean Time Between Failure) or Higher Failure Rates
 - Pitting at contact breaker points which leads to mistimed firing and loss of power
 - Frequent maintenance needs at contact breakers
 - Starting problems especially when battery is discharged.



- To overcome the above stated limitations, following electronic ignition systems are nowadays used in most of the automobiles.
 - Transistorized Coil Ignition (TCI) System
 - Capacitor Discharge Ignition (CDI) System



□ Transistorized Coil Ignition (TCI) System

- TCI System is nowadays most widely used ignition system in most of the automobiles (two and three wheeled vehicles)
- This system is also referred to as Transistor Assisted Contact (TAC) System
- Fig. shows TCI System. This system retains the contact breaker point used in conventional system.
- Contact breaker point (operated using cam and follower mechanism) is connected to the base of transistor.
- Emitter of the transistor is connected to the primary windings of the ignition coil and collector is electronically earthed (or grounded).



- The current flow in this system is around $1/10^{\text{th}}$ times lesser than the conventional ignition system.
- Ballast resistor is used to avoid the damage of ignition coil by overheating.
- Life of Contact breaker points is more due to use of transistor technology.

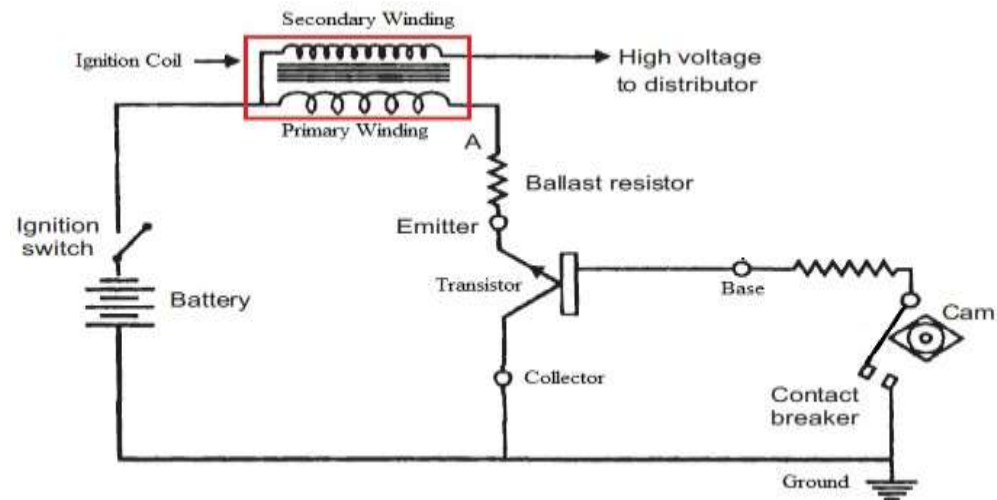



❖ **Advantages:**

- Reduced wear and tear of Contact Breaker Points
- No misfiring and no loss of power
- Higher ignition voltage
- Longer spark plug life thereby reducing running cost
- More reliable in operation
- Improved ignition even at lower air-fuel ratios (lean charge)
- Lower contact bouncing and increased dwell

❖ **Disadvantages:**

- Higher cost due to additional electronic components
- Contact Breaker CB Points are needed (i.e. they cannot be eliminated)
- Maximum engine speed is restricted by shortcomings of contact breaker

❖ **Applications:**

- Used in modern and new two wheelers like Royal Enfield Thunderbird, Hero Karizma ZMR, Yamaha FZ, Honda Dream Neo, Honda Dream Yuga etc.



□ Capacitor Discharge Ignition (CDI) System

- Fig. shows CDI System which is another type of electronic ignition system.
- A 6 Volts battery is connected to DC to DC Transistor Control Unit which can give high voltage output (of the order of 300 Volts).
- Capacitor (also called as condenser) is charged to this output voltage.
- Resistance is used to control the current needed by SCR (Silicon Controlled Rectifier) so that firing angle of SCR can be changed as per the needs.
- Capacitor undergoes discharge when SCR triggering unit sends a pulse to create high voltage in secondary coil which causes current to jump across air gap between the electrodes producing the required spark.

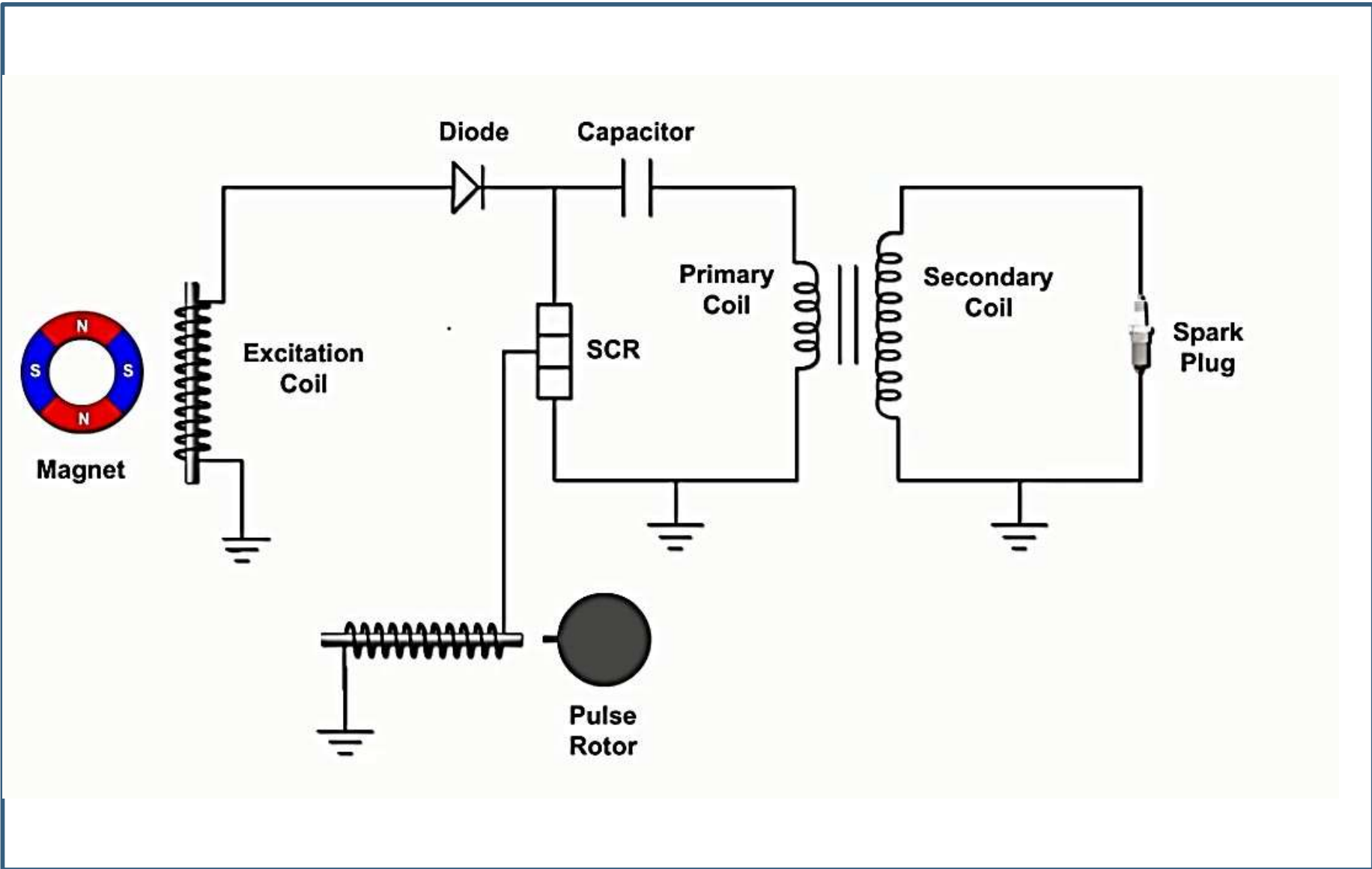



❖ **Advantages:**

- Need of CB (Contact Breaker) Points is eliminated
- Increased life of spark plug
- Better performance at all operating conditions
- Strength of spark is better
- Performance is not affected due to electrical shunts arising due to spark plug fouling

❖ **Disadvantages:**

- Higher cost due to additional components like capacitor, SCR (Silicon Controlled Rectifier)
- Fast capacitor discharge leads to strong spark, however, for very short duration of time (0.1 to 0.25 milliseconds) which can cause ignition failures at lower air-fuel ratios.

❖ **Applications:**

- Used in motorcycles, lawn mowers, chainsaws, small engines, turbine- powered aircrafts, and some cars. For example, Bajaj Discover 100, Bajaj Discover 150, Honda CB Twister, Honda CB Unicorn etc.



Performance Curves of Conventional and Electronic Ignition System

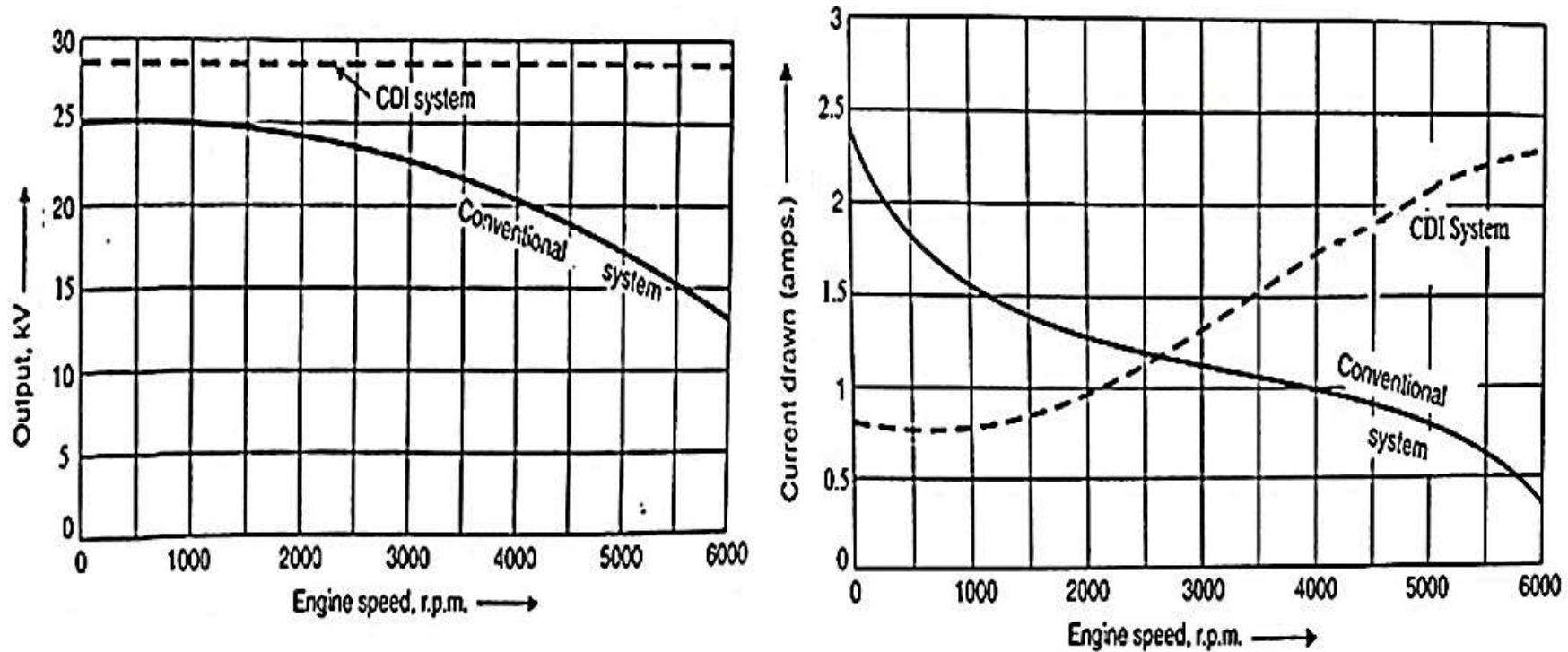



❑ Spark Plug:

- The main function of spark plug is to receive the high tension (voltage) current supplied by secondary winding of ignition coil and produce a high intensity spark across the spark gap. This spark is used for combustion of air-fuel mixture.
- The Fig. below shows the schematic diagram of spark plug. The first spark plug was used by Lenoir (in 1860) in his gas engine.
- The spark plug consists of contact terminal, metal case, insulator, seals and two electrodes viz., central electrodes and metal tongue (ground electrode) etc.
- The central electrode is connected to the contact terminal. Contact terminal is connected to the secondary winding carrying high voltage current.



- The central electrode is electrically isolated using the porcelain insulator. The central electrode extends through the porcelain insulator in the combustion chamber. Generally, the spark gap of a spark plug in most of automobiles is in between 0.9–1.8 mm.
- As the high voltage current surges across the spark gap, it raises the temperature of the spark channel (gap) to 60,000 K. This heat in the spark channel results in expansion of ionized gases very quickly, like a **small explosion**. The sound of this explosion can be heard when observing the spark, which is similar to lightning.

