

## Unit – III: Form Measurements

### 3. Form Measurements

#### Technical Terms

- **Pitch**

It is the distance measured parallel to the screw threads axis between the corresponding points on two adjacent threads in the same axial plane. The basic pitch is equal to the lead divided by the number of thread starts.

- **Lead:**

The axial distance advanced by the screw in one revolution is the lead.

- **Addendum**

Radial distance between the major and pitch cylinders for external thread. Radial distance between the minor and pitch cylinder for internal thread.

- **Dedendum**

It is the radial distance between the pitch and minor cylinders for external thread. Also radial distance between the major and pitch cylinders for internal thread.

- **Pressure angle (a)**

It is the angle making by the line of action with the common tangent to the pitch circles of mating gears.

- **Module(m)**

It is the ratio of pitch circle diameter to the total number of teeth

- **Lead angle**

It is the angle between the tangent to the helix and plane perpendicular to the axis of cylinder.

- **Straightness**

A line is said to be straight over a given length, if the variation of the distance of its from two planes perpendicular to each other and parallel to the general direction of the line remains within the specified tolerance limits

- **Roundness** Roundness is defined as a condition of a surface of revolution. Where all points of the surface intersected by any plane perpendicular to a common axis in case of cylinder and cone.

#### Introduction

Threads are of prime importance, they are used as fasteners. It is a helical groove, used to transmit force and motion. In plain shaft, the hole assembly, the object of dimensional control is

to ensure a certain consistency of fit. The performance of screw threads during their assembly with nut depends upon a number of parameters such as the condition of the machine tool used for screw cutting, work material and tool.

- Form measurement includes
- Screw thread measurement
- Gear measurement
- Radius measurement
- Surface Finish measurement
- Straightness measurement
- Flatness and roundness measurements

### 3.1.1 Screw Thread Measurement

Screw threads are used to transmit the power and motion, and also used to fasten two components with the help of nuts, bolts and studs. There is a large variety of screw threads varying in their form, by included angle, head angle, helix angle etc. The screw threads are ainy classified into 1) External thread 2) Internal thread.

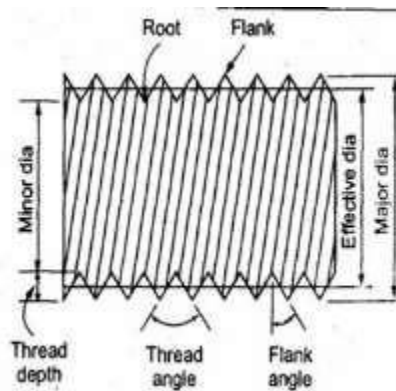

Fig 3.1 External Thread

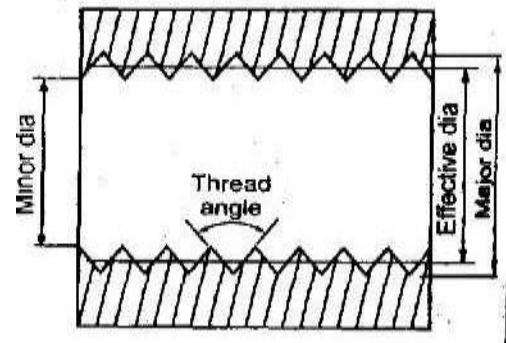
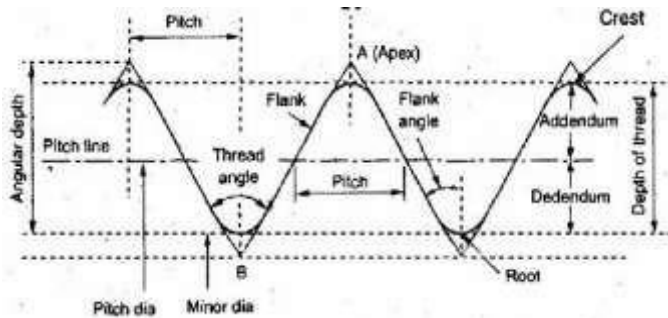

Fig 3.2 Internal Thread

### Screw Thread Terminology



- **Pitch**

It is the distance measured parallel to the screw threads axis between the corresponding points on two adjacent threads in the same axial plane. The basic pitch is equal to the lead divided by the number of thread starts.

- **Minor diameter:**

It is the diameter of an imaginary co-axial cylinder which touches the roots of external threads.

- **Major diameter:**

It is the diameter of an imaginary co-axial cylinder which touches the crests of an external thread and the root of an internal thread.

- **Lead:**

The axial distance advanced by the screw in one revolution is the lead.

- **Pitch diameter:**

It is the diameter at which the thread space and width are equal to half of the screw thread

- **Helix angle:**

It is the angle made by the helix of the thread at the pitch line with the axis. The angle is measured in an axial plane.

- **Flank angle:**

It is the angle between the flank and a line normal to the axis passing through the apex of the thread.

- **Height of thread:**

It is the distance measured radially between the major and minor diameters respectively

- **Addendum:**

Radial distance between the major and pitch cylinders for external thread.

Radial distance between the minor and pitch cylinder for internal thread.

- **Dedendum:**

It is the radial distance between the pitch and minor cylinders for external thread. Also radial distance between the major and pitch cylinders for internal thread.

## **Error in Thread**

The errors in screw thread may arise during the manufacturing or storage of threads. The errors either may cause in following six main elements in the thread.

- 1) Major diameter error
- 2) Minor diameter error
- 3) Effective diameter error

- 4) Pitch error
- 5) Flank angles error
- 6) Crest and root error

**1) Major diameter error**

It may cause reduction in the flank contact and interference with the matching threads.

**2) Minor diameter error**

It may cause interference, reduction of flank contact.

**3) Effective diameter error**

If the effective diameter is small the threads will be thin on the external screw and thick on an internal screw.

**4) Pitch errors**

If error in pitch, the total length of thread engaged will be either too high or too small. The various pitch errors may classified into

1. Progressive error
2. Periodic error
3. Drunken error
4. Irregular error

**1) Progressive error**

The pitch of the thread is uniform but is longer or shorter its nominal value and this is called progressive.

**Causes of progressive error:**

1. Incorrect linear and angular velocity ratio.
2. In correct gear train and lead screw.
3. Saddle fault.
4. Variation in length due to hardening.

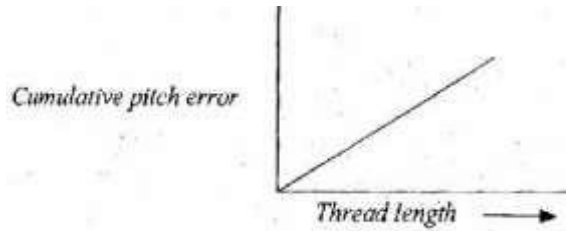

**Fig 3.4 Progressive Error**

**2) Periodic error**

These are repeats itself at regular intervals along the thread

**Causes of periodic error:**

1. Un uniform tool work velocity ratio.
2. Teeth error in gears.
3. Lead screw error.
4. Eccentric mounting of the gears.

**3) Drunken error**

Drunken errors are repeated once per turn of the thread in a drunken thread. In Drunken thread the pitch measured parallel to the thread axis. If the thread is not cut to the true helix the drunken thread error will form

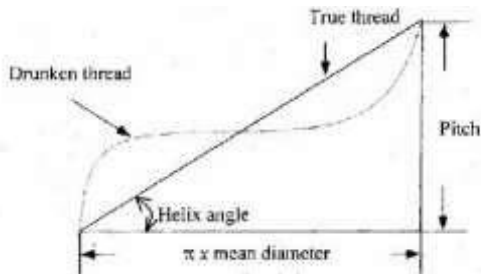

**Fig 3.5 Drunken Error**

**4) Irregular errors**

It is vary irregular manner along the length of the thread.

**Irregular error causes:**

1. Machine fault.
2. Non-uniformity in the material.
3. Cutting action is not correct.
4. Machining disturbances.

### **Effect of pitch errors**

- Increase the effective diameter of the bolt and decreases the diameter of nut.
- The functional diameter of the nut will be less.
- Reduce the clearance.
- Increase the interference between mating threads.

### **Measurement of various elements of Thread**

To find out the accuracy of a screw thread it will be necessary to measure the following:

1. Major diameter.
2. Minor diameter.
3. Effective or Pitch diameter.
4. Pitch
5. Thread angle and form

#### **1. Measurement of major diameter:**

The instruments which are used to find the major diameter are by

- Ordinary micrometer
- Bench micrometer.
- **Ordinary micrometer**

The ordinary micrometer is quite suitable for measuring the external major diameter. It is first adjusted for appropriate cylindrical size (S) having the same diameter (approximately). This process is known as 'gauge setting'. After taking this reading 'R' the micrometer is set on the major diameter of the thread, and the new reading is 'R2'.

- **Bench micrometer**

For getting the greater accuracy the bench micrometer is used for measuring the major diameter. In this process the variation in measuring Pressure, pitch errors are being neglected. The fiducial indicator is used to ensure all the measurements are made at same pressure. The instrument has a micrometer head with a vernier scale to read the accuracy of 0.002mm. Calibrated setting cylinder having the same diameter as the major diameter of the thread to be measured is used as setting standard. After setting the standard, the setting cylinder is held between the anvils and the reading is taken. Then the cylinder is replaced by the threaded work piece and the new reading is taken.

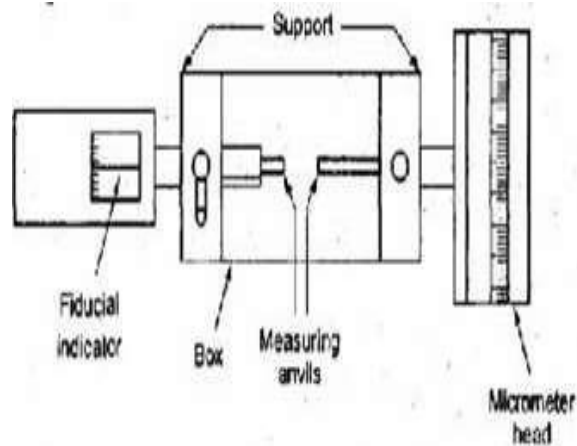

**Fig 3.6 Bench Micrometer**

∴ The major diameter of screw thread

$$= S \pm (D_2 - D_1)$$

Where,  $S$  = Diameter of the setting cylinder.

$R_2$  = Micrometer Reading on screw thread

$R_1$  = Micrometer reading on setting cylinder.

- **Measurement of the major diameter of an Internal thread**

The Inter thread major diameter is usually measured by thread comparator fitted with ball-ended styli. First the Instrument is set for a cylindrical reference having the same diameter of major diameter of internal thread and the reading is taken. Then the floating head is retracted to engage the tips of the styli at the root of spring under pressure. For that the new

major diameter of internal thread is  $= D \pm (R_2 - R_1)$

$D$  = Cylindrical standard diameter

$R_2$  = Thread reading

$R_1$  = Dial Indicator reading on the standard.

reading is taken,

## 2. Measurement of Minor diameter

The minor diameter is measured by a comparative method by using floating carriage diameter measuring machine and small V pieces which make contact with the root of the thread. These V pieces are made in several sizes, having suitable radii at the edges. V pieces are made of hardened steel. The floating carriage diameter-measuring machine is a bench micrometer mounted on a carriage.



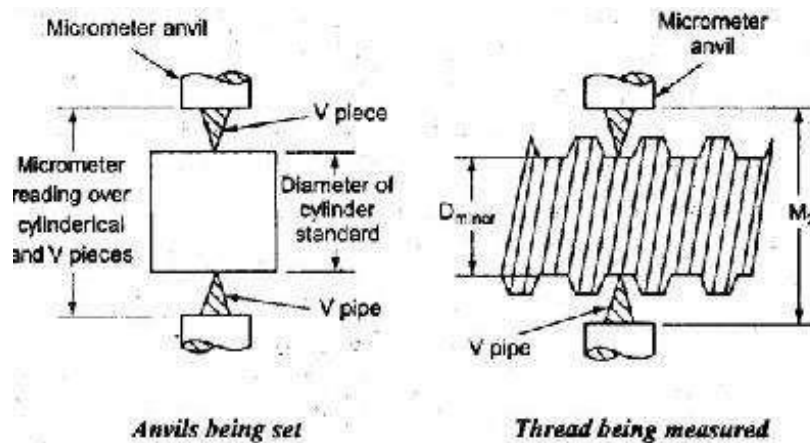

**Fig 3.7 Measurement of Minor diameter**

- **Measurement process**

The threaded work piece is mounted between the centers of the instrument and the V pieces are placed on each side of the work piece and then the reading is noted. After taking this reading the work piece is then replaced by a standard reference cylindrical setting gauge.

The minor diameter of the thread =  $D \pm (R_2 - R_1)$

Where,  $D$  = Diameter of cylindrical gauge

$R_2$  = Micrometer reading on threaded work piece.

$R_1$  = Micrometer reading on cylindrical gauge.

- **Measurement of Minor diameter of Internal threads**

The Minor diameter of Internal threads are measured by

1. Using taper parallels
2. Using Rollers.

- **Using taper parallels**

For diameters less than 200mm the use of Taper parallels and micrometer is very common. The taper parallels are pairs of wedges having reduced and parallel outer edges. The diameter across their outer edges can be changed by sliding them over each other.

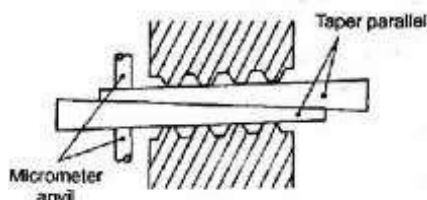

**Fig 3.8 Taper parallels**

- **Using rollers**

For more than 20mm diameter this method is used. Precision rollers are inserted inside the thread and proper slip gauge is inserted between the rollers. The minor diameter is then the length of slip gauges plus twice the diameter of roller.

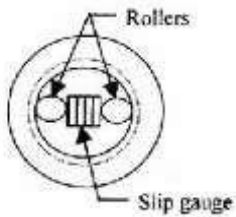

**Fig 3.9 Roller gauge**

### 3. Measurement of effective diameter

Effective diameter measurement is carried out by following methods.

1. One wire,
2. Two wires, or
3. Three wires method.
4. Micrometer method.

#### a) One wire method

The only one wire is used in this method. The wire is placed between two threads at one side and on the other side the anvil of the measuring micrometer contacts the crests. First the micrometer reading  $d_1$  is noted on a standard gauge whose dimension is approximately same to be obtained by this method.

i.e. ' $d_2$ ' then effective diameter =  $D \pm (d_1 - d_2)$

When  $D$  = Size of setting gauge

Actual measurement over wire on one side and threads on other

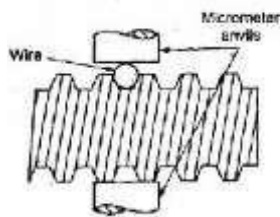

**Fig 3.10 One wire method**

### b) Two wire method

Two-wire method of measuring the effective diameter of a screw thread is given below. In this method wires of suitable size are placed between the standard and the micrometer anvils. First the micrometer reading is taken and let it be  $R$ . Then the standard is replaced by the screw thread to be measured and the new reading is taken.

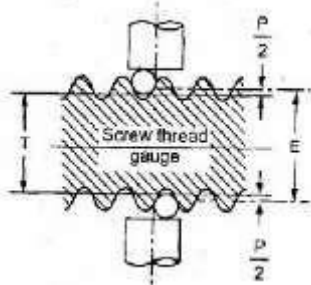
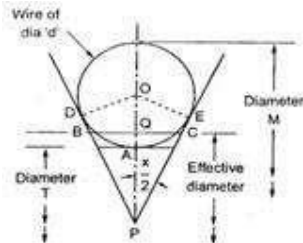

Fig 3.11 Two Wire Method



From the above reading

The effective diameter  $E$  is calculated by  $E = T + P$

Where,  $T =$  Dimension under the wires  $= M - 2d$

$M =$  Dimension over the wires

$d =$  diameter of each wire

If  $P' =$  Pitch of thread then

$$P = 0.9605 P' - 1.1657d \Rightarrow \text{Whitworth thread.}$$

$$P = 0.866 P' - d \Rightarrow \text{For metric thread.}$$

Here,  $P =$  The difference between the effective diameter and the diameter under the wires.

The diameter under the wires ' $T$ ' also can be determined by

$$T = S - (R_1 - R_2)$$

Where,  $S =$  The diameter of the standard.

The  $P$  value can be derived in terms of  $P$  (Pitch),  $d$  (Diameter of wire) and  $x$  thread angle is as follows

BC lies on the effective diameter.

$$\therefore BC = \frac{1}{2} \text{ Pitch} = \frac{1}{2} P$$

$$\text{Next OP} = \frac{d \operatorname{Cosec}(x/2)}{2}$$

And  $AQ = PQ - AP$

Where,

$$PQ = QC \operatorname{Cot}(x/2) = P/4 \operatorname{Cot}(x/2)$$

$$PQ = \frac{P}{4} \operatorname{Cot}(x/2)$$

### c) Three-Wire method

The three-wire method is the accurate method. In this method three wires of equal and precise diameter are placed in the grooves at opposite sides of the screw. In this one wire on one side and two on the other side are used. The wires either may held in hand or hung from a stand. This method ensures the alignment of micrometer anvil faces parallel to the thread axis.

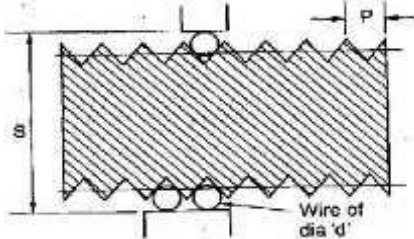
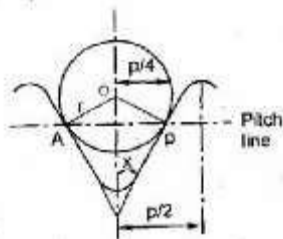

Fig 3.12 Three-Wire Method

### • BEST WIRE SIZE-DEVIATION

Best wire diameter is that may contact with the flanks of the thread on the pitch line. The figure shows the wire makes contact with the flanks of the thread on the pitch line.

Hence best wire diameter,



$$db = 2Ap \sec x$$

Where,  $db$  = Wire diameter

$x$  = Included angle

$$AP = p/4$$

$$\therefore db = 2 p/4 \sec x$$

$$db = p_2 \sec x$$

## 4. Pitch measurement

The most commonly used methods for measuring the pitch are

1. Pitch measuring machine

2. Tool maker's microscope
3. Screw pitch gauge

- **Pitch measuring machine**

The principle of the method of measurement is to move the stylus along the screen parallel to the axis from one space to the next. The pitch-measuring machine provides a relatively simple and accurate method of measuring the pitch. Initially the micrometer reading is near the zero on the scale, the indicator is moved along to bring the stylus, next the indicator adjusted radially until the stylus engages between the thread flank and the pointer 'K' is opposite in the line L. To bring T in opposite in its index mark a small movement is necessary in the micrometer and then the reading is taken next. The stylus is moved along into the next space by rotation of the micrometer and the second reading is taken. The difference between these two- measured readings is known as the pitch of the thread.

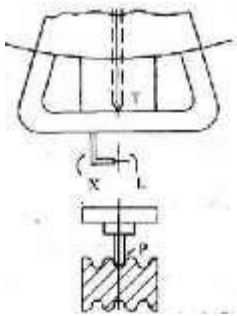
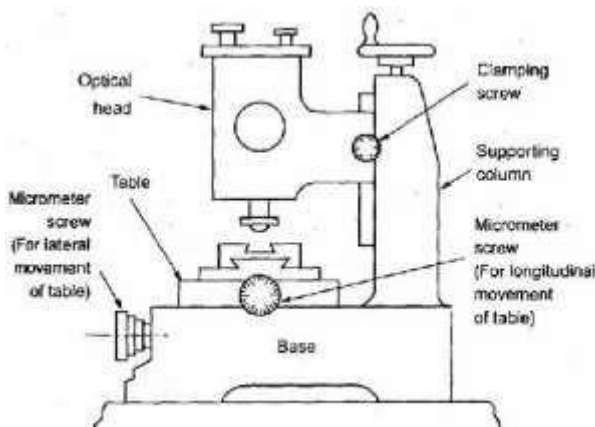

**Fig 3.13 Pitch Measuring Machine**

- **Tool makers microscope**

**Working**

Worktable is placed on the base of the base of the instrument. The optical head is mounted on a vertical column it can be moved up and down. Work piece is mounted on a glass plate. A light source provides horizontal beam of light which is reflected from a mirror by 90° upwards towards the table. Image of the outline contour of the work piece passes through the objective of the optical head. The image is projected by a system of three prisms to a ground glass screen. The measurements are made by means of cross lines engraved on the ground glass screen. The screen can be rotated through 360°.



Different types of graduated screens and eyepieces are used.

### **Fig 3.14 Tool Makers Microscope**

Applications

- Linear measurements.
- Measurement of pitch of the screw.
- Measurement of pitch diameter. ○ Measurement of thread angle.
- Comparing thread forms.
- Centre to center distance measurement.
- Thread form and flank angle measurement

- **Thread form and flank angle measurement**

The optical projections are used to check the thread form and angles in the thread. The projectors equipped with work holding fixtures, lamp, and lenses. The light rays from the lens are directed into the cabinet and prisms and mirrors. The enlarged image of thread is drawn. The ideal and actual forms are compared for the measurement.

## **GEAR MEASUREMENT**

### **Introduction**

Gear is a mechanical drive which transmits power through toothed wheel. In this gear drive, the driving wheel is in direct contact with driven wheel. The accuracy of gearing is the very important factor when gears are manufactured. The transmission efficiency is almost 99 in gears. So it is very important to test and measure the gears precisely. For proper inspection of gear, it is very important to concentrate on the raw materials, which are used to manufacture the gears, also very important to check the machining the blanks, heat treatment and the finishing of teeth. The gear blanks should be tested for dimensional accuracy and tooth thickness for the forms of gears.

The most commonly used forms of gear teeth are

1. Involute
2. Cycloidal

The involute gears also called as straight tooth or spur gears. The cycloidal gears are used in heavy and impact loads. The involute rack has straight teeth. The involute pressure angle is either  $20^\circ$  or  $14.5^\circ$ .

### **Types of gears**

#### **1. Spur gear**

Cylindrical gear whose tooth traces is straight line. These are used for transmitting power between parallel shafts.

#### **2. Spiral gear**

The tooth of the gear traces curved lines.

### **3. Helical gears**

These gears used to transmit the power between parallel shafts as well as nonparallel and non-intersecting shafts. It is a cylindrical gear whose tooth traces is straight line.

### **4. Bevel gears:**

The tooth traces are straight-line generators of cone. The teeth are cut on the conical surface. It is used to connect the shafts at right angles.

### **5. Worm and Worm wheel:**

It is used to connect the shafts whose axes are non-parallel and non-intersecting.

### **6. Rack and Pinion:**

Rack gears are straight spur gears with infinite radius.

## **Gear terminology**

### **1. Tooth profile**

It is the shape of any side of gear tooth in its cross section.

### **2. Base circle**

It is the circle of gear from which the involute profile is derived. Base circle diameter  
Pitch circle diameter x Cosine of pressure angle of gear

### **3. Pitch circle diameter (PCD)**

The diameter of a circle which will produce the same motion as the toothed gear wheel.

### **4. Pitch circle**

It is the imaginary circle of gear that rolls without slipping over the circle of its mating gear.

### **5. Addendum circle**

The circle coincides with the crests (or) tops of teeth.

### **6. Dedendum circle (or) Root circle**

This circle coincides with the roots (or) bottom on teeth.

### **7. Pressure angle (a)**

It is the angle making by the line of action with the common tangent to the pitch circles of mating gears.

### **8. Module(m)**

It is the ratio of pitch circle diameter to the total number of teeth. Where,  $d$  = Pitch circle diameter.  $n$  = Number of teeth.

### **9. Circular pitch**

It is the distance along the pitch circle between corresponding points of adjacent teeth.

**10. Addendum**

Radial distance between tip circle and pitch circle. Addendum value = 1 module.

**11 Dedendum**

Radial distance between pitch circle and root circle, Dedendum value = 1.25module.

**12. Clearance (C)**

Amount of distance made by the tip of one gear with the root of mating gear. Clearance = Difference between Dedendum and addendum values.

**13. Blank diameter:**

The diameter of the blank from which gear is out. Blank diameter = PCD + 2m

**14. Face:**

Part of the tooth in the axial plane lying between tip circle and pitch circle.

**15. Flank:**

Part of the tooth lying between pitch circle and root circle.

**16. Top land:**

Top surface of a tooth.

**17. Lead angle**

The angle between the tangent to the helix and plane perpendicular to the axis of cylinder.

**18. Backlash:**

The difference between the tooth thickness and the space into which it meshes.

$$\text{Back lash} = t_2 - t_1$$

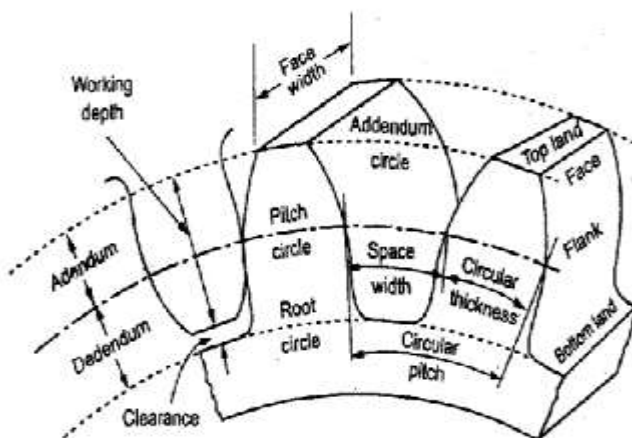

Fig 3.15 Gear Profile



## **Gear errors**

1. **Profile error:** - The maximum distance of any point on the tooth profile form to the design profile.
2. **Pitch error:** - Difference between actual and design pitch
3. **Cyclic error:** - Error occurs in each revolution of gear
4. **Run out:** - Total range of reading of a fixed indicator with the contact points applied to a surface rotated, without axial movement, about a fixed axis.
5. **Eccentricity:** - Half the radial run out
6. **Wobble:** - Run out measured parallel to. the axis of rotation at a specified distance from the axis
7. **Radial run out:** - Run out measured along a perpendicular to the axis of rotation.
8. **Undulation:** - Periodical departure of the actual tooth surface from the design surface.
9. **Axial run out:** - Run out measured parallel to the axis of rotation at a speed.
10. **Periodic error:** -Error occurring at regular intervals.

## **Gear Measurement**

The Inspection of the gears consists of determine the following elements in which manufacturing error may be present.

1. Runout.
2. Pitch
3. Profile
4. Lead
5. Back lash
6. Tooth thickness

7. Concentricity

8. Alignment

### 1. Runout:

It means eccentricity in the pitch circle. It will give periodic vibration during each revolution of the gear. This will give the tooth failure in gears. The run out is measured by means of eccentricity testers. In the testing the gears are placed in the mandrel and the dial indicator of the tester possesses special tip depending upon the module of the gear and the tips inserted between the tooth spaces and the gears are rotated tooth by tooth and the variation is noted from the dial indicator.

### 2. Pitch measurement:

There are two ways for measuring the pitch.

1. Point to point measurement (i.e. One tooth point to next tooth point)

2. Direct angular measurement

#### 1. Tooth to Tooth measurement

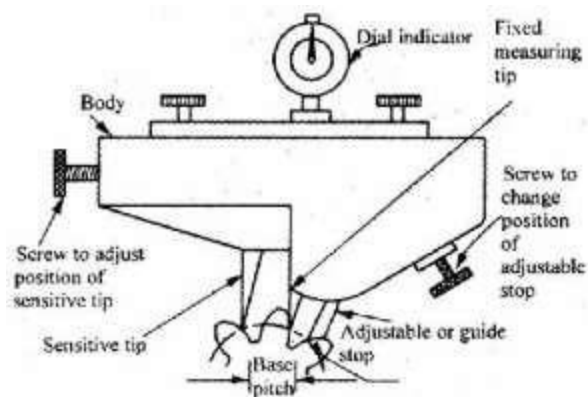

**Fig 3.16 Tooth to tooth measurement**

The instrument has three tips. One is fixed measuring tip and the second is sensitive tip, whose position can be adjusted by a screw and the third tip is adjustable or guide stop. The distance between the fixed and sensitive tip is equivalent to base pitch of the gear. All the three tips are contact the tooth by setting the instrument and the reading on the dial indicator is the error in the base pitch.

### 2. Direct Angular Measurement

It is the simplest method for measuring the error by using set dial gauge against a tooth. In this method the position of a suitable point on a tooth is measured after the gear has been indexed by a suitable angle. If the gear is not indexed through the angular pitch the reading differs from the original reading. The difference between these is the cumulative pitch error.

### 3. Profile checking

The methods used for profile checking is

1. Optical projection method.
2. Involute measuring machine.

### 1. Optical projection method:

The profile of the gear projected on the screen by optical lens and then projected value is compared with master profile.

### 2. Involute measuring machine:

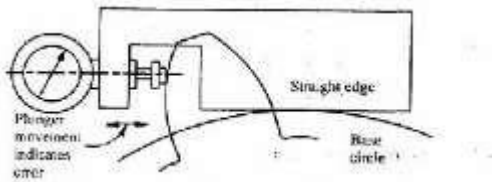

**Fig 3.17 Involute Measuring Machine**

In this method the gear is held on a mandrel and circular disc of same diameter as the base circle of gear for the measurement is fixed on the mandrel. After fixing the gear in the mandrel, the straight edge of the instrument is brought in contact with the base circle of the disc. Now, the gear and disc are rotated and the edge moves over the disc without slip. The stylus moves over the tooth profile and the error is indicated on the dial gauge.

### 4. Lead checking:

It is checked by lead checking instruments. Actually lead is the axial advance of a helix for one complete turn. The lead checking instruments advance a probe along a tooth surface, parallel to the axis when the gear rotates.

### 5. Backlash checking:

Backlash is the distance through which a gear can be rotated to bring its nonworking flank in contact with the teeth of mating gear. Numerical values of backlash are measured at the tightest point of mesh on the pitch circle.

There are two types of backlash

1. Circumferential backlash
2. Normal backlash

The determination of backlash is, first one of the two gears of the pair is locked, while other is rotated forward and backward and by the comparator the maximum displacement is measured. The stylus of comparator is locked near the reference cylinder and a tangent to this is called circular backlash.

### 6. Tooth thickness measurement:

Tooth thickness is generally measured at pitch circle and also in most cases the chordal thickness measurement is carried out i.e. the chord joining the intersection of the tooth profile with the pitch circle.

The methods which are used for measuring the gear tooth thickness is

- a) Gear tooth vernier caliper method (Chordal thickness method)

- b) Base tangent method.
- c) Constant chord method.
- d) Measurement over pins or balls.

**a) Gear tooth vernier method**

In gear tooth vernier method the thickness is measured at the pitch line. Gear tooth thickness varies from the tip of the base circle of the tooth, and the instrument is capable of measuring the thickness at a specified position on the tooth. The tooth vernier caliper consists of vernier scale and two perpendicular arms. In the two perpendicular arms one arm is used to measure the thickness and other arm is used to measure the depth. Horizontal vernier scale reading gives chordal thickness (W) and vertical vernier scale gives the chordal addendum. Finally the two values compared.

The theoretical values of W and d can be found out by considering one tooth in the gear and it can be verified. In fig noted that w is a chord ADB and tooth thickness is specified by AEB. The distance d is noted and adjusted on instrument and it is slightly greater than addendum CE.

∴ 'W' is chordal thickness and 'd' is named as chordal addendum.

$$\text{So, } W = AB = 2AD$$

And angle,  $\text{AOD} = \theta = \frac{360}{n}$

Where, n = Number of teeth.

$$W = 2AD = 2 \times AO \sin\theta$$

$$= 2R \sin \frac{360}{4n} \dots\dots$$

Where, R = Pitch circle radius

$$\text{Module, } m = \frac{P.C.D}{\text{No. of teeth}} = \frac{2R}{n}$$

$$\therefore R = \frac{nm}{2}$$

$$\text{And } OD = R \cos\theta = \frac{nm}{2} \cos\left(\frac{90}{n}\right)$$

$$\boxed{OD = \frac{nm}{2} \cos\left(\frac{90}{n}\right)}$$

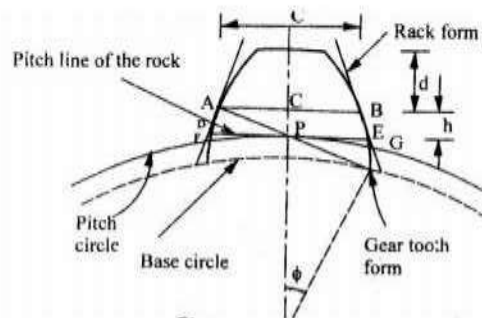

Vernier method like the chordal thickness and chordal addendum are dependent upon the number of teeth. Due to this for measuring large number of gears different calculations are to be made for each gear. So these difficulties are avoided by this constant chord method.

**b) Measurement over Rolls or balls**

A very good and convenient method for measuring thickness of gear. In this method two or three different size rollers are used for checkup the vibrations at several places on the

tooth.

### 7. Measurement of concentricity

In setting of gears the centre about which the gear is mounded should be coincident with the centre from which the gear is generated. It is easy to check the concentricity of the gear by mounting the gear between centers and measuring the variation in height of a roller placed between the successive teeth. Finally the variation in reading will be a function of the eccentricity present.

### 8. Alignment checking

It is done by placing a parallel bar between the gear teeth and the gear being mounted between centres. Finally the readings are taken at the two ends of the bar and difference in reading is the misalignment.

### Parkinson Gear Tester Working principle

The master gear is fixed on vertical spindle and the gear to be tested is fixed on similar spindle which is mounted on a carriage. The carriage which can slide either side of these gears are maintained in mesh by spring pressure. When the gears are rotated, the movement of sliding carriage is indicated by a dial indicator and these variations arc is measure of any irregularities. The variation is recorded in a recorder which is fitted in the form of a waxed circular chart. In the gears are fitted on the mandrels and are free to rotate without clearance and the left

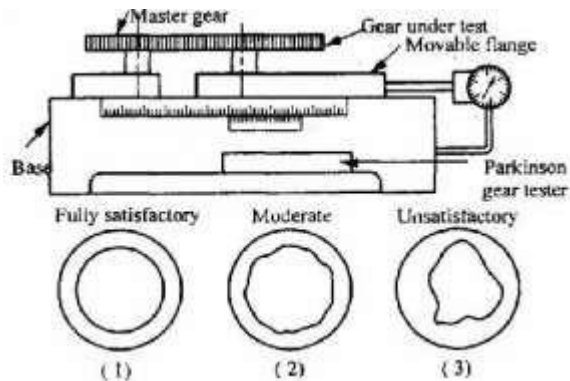

mandrel move along the table and the right mandrel move along the spring-loaded carriage.

**Fig 3.18 Parkinson Gear Tester**

The two spindles can be adjusted so that the axial distance is equal and a scale is attached to one side and vernier to the other, this enables center distance to be measured to within 0.025mm. If any errors in the tooth form when gears are in close mesh, pitch or concentricity of pitch line will cause a variation in center distance from this movement of carriage as indicated to the dial gauge will show the errors in the gear test. The recorder also fitted in the form of circular or rectangular chart and the errors are recorded.

Limitations of Parkinson gear tester:

1. Accuracy  $\pm 0.001$ mm
2. Maximum gear diameter is 300mm
3. Errors are not clearly identified:

4. Measurement dependent upon the master gear.

5. Low friction in the movement of the floating carriage.

## RADIUS MEASUREMENT

In radius measurement we are going to see about two methods namely.

1. Radius of circle and

2. Radius of concave surface

### 1. Radius of circle

This radius measurement requires the use of vernier caliper, C-Clamp, surface plate and two pins. This method is very much used in measuring the cap of bearing. Initially the job is fixed on surface plate with the help of C-clamp. So that the central position of the circular part is touched with the surface plate. Next the two balls are placed on both sides of the work and using the vernier caliper readings are taken.

Let,  $R$  = Radius of job,  $l$  = The reading between two balls

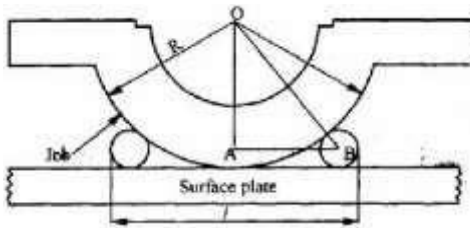

Fig 3.19 Radius Measurement

Now, from fig.  $OB^2 = OA^2 + AB^2$

It is written like this

$$(R + d/2)^2 = (R - d/2)^2 + \left(\frac{l-d}{2}\right)^2$$

$$R^2 + (d/2)^2 + 2Rd/2 = R^2 + d^2/4 - 2Rd/2 + \left(\frac{l-d}{2}\right)^2$$

$$2Rd = \frac{(l-d)^2}{4}$$

$$\therefore Rd = \frac{(l-d)^2}{8}$$

$$\therefore d = \frac{(l-d)^2}{8d}$$

## 2. Radius of concave surface

Here there are two methods

- Edges are well defined.
- Edges are rounded up

### 1. Edges are well defined

In this method radius is calculated by using surface plate, height gauge, angle plate, C-clamp and slip gauges. First the Job placed on the surface plate and then by using depth micrometer the depth is measured and it is h. Next in such a way that cavity is resting against an angle plate and the part is clamped in this position. By using a height gauge edge to edge size of hole is measured and this is diameter of d.

From the above fig.

Let, O = Centre of the cavity

From the above fig.

$$OA^2 = AB^2 + BO^2 \quad \text{Here, } OA = R$$

$$R^2 = \left(\frac{d}{2}\right)^2 + (R-h)^2$$

$$= \frac{d^2}{4} + R^2 + h^2 - 2Rh$$

$$R = \frac{\frac{d^2}{4} + h^2}{2h} = \frac{d^2}{8h} + \frac{h}{2}$$

$$\therefore \text{Radius } R = \frac{d^2}{8h} + \frac{h}{2}$$

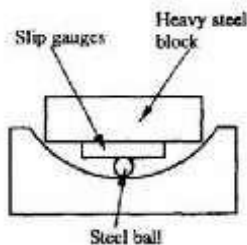

**Fig 3.20 Radius of Concave surface**

When cavities are rounded up the radius is measured by depth micrometer and slip gauges. First the width of the micrometer is measured by slip gauges and it is let ' d'. Then it is placed in the cavity and measuring tip is lowered down to touches the base. From this condition the reading is noted and it be h and the radius is measured by using the formula

### 2) Edges are rounded up

When cavities are rounded up the radius is measured by depth micrometer and slip gauges.

First the width of the micrometer is measured by slip gauges and it is let 'd'. Then it is placed in the cavity and measuring tip is lowered down to touches the base. From this condition the reading is noted and it be h and the radius is measured by using the formula

$$R = \frac{d^2}{8h} + \frac{h^2}{2}$$

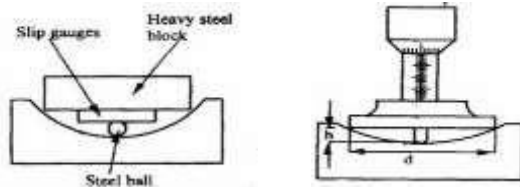

Fig 3.21 Edges round up

### Surface Finish Measurement

#### Introduction

When we are producing components by various methods of manufacturing process it is not possible to produce perfectly smooth surface and some irregularities are formed. These irregularities are causes some serious difficulties in using the components. So it is very important to correct the surfaces before use. The factors which are affecting surface roughness are

1. Work piece material
2. Vibrations
3. Machining type
4. Tool and fixtures

The geometrical irregularities can be classified as

1. First order
2. Second order
- 3.3 Third order
4. Fourth order

#### 1. First order irregularities

These are caused by lack of straightness of guide ways on which tool must move.

#### 2. Second order irregularities

These are caused by vibrations

#### 3. Third order irregularities

These are caused by machining.

#### 4. Fourth order irregularities

These are caused by improper handling machines and equipments.



## Elements of surface texture

1. **Profile:** - Contour of any section through a surface.
2. **Lay:** - Direction of the 'predominate surface pattern'
3. **Flaws:** - Surface irregularities or imperfection, which occur at infrequent intervals.
4. **Actual surface:** - Surface of a part which is actually obtained,
5. **Roughness:** - Finely spaced irregularities. It is also called primary texture.
6. **Sampling lengths:** - Length of profile necessary for the evaluation of the irregularities.
7. **Waviness:** - Surface irregularities which are of greater spacing than roughness.
8. **Roughness height:** - Rated as the arithmetical average deviation.
9. **Roughness width:** - Distance parallel to the normal surface between successive peaks.
10. **Mean line of profile:** - Line dividing the effective profile such that within the sampling length.
11. **Centre line of profile:** - Line dividing the effectiveness profile such that the areas embraced b profile above and below the line are equal.

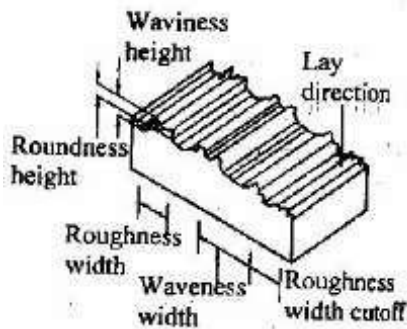

**Fig 3.22 Surface Texture**

### Analysis of surface finish

The analyses of surface finish being carried out by

1. The average roughness method.
2. Peak to valley height method
3. From factor

#### 1. Average roughness measurement

The assessment of average roughness is carried out by a Centre line average (CLA). b Root mean square (RMS) c Ten point method

##### a.C.L.A. method

The surface roughness is measured as the average deviation from the nominal surface.

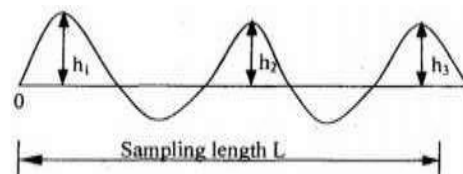
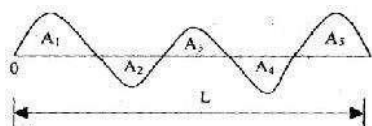

$$\text{C. L. A. Value} = \frac{A_1 + A_2 + A_3 + \dots + A_n}{L}$$

$$\text{C. L. A.} = \frac{\sum A}{L}$$

Where,  $\sum A$  = Average area  
 $L$  = Total length

### b. .M.S. method

The roughness is measured as the average deviation from the nominal surface. Let,  $h_1, h_2,$  are the heights of the ordinates and  $L$  is the sampling length

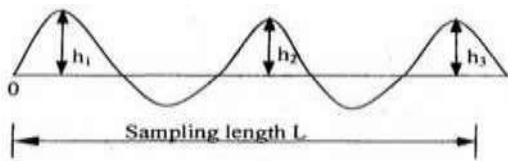

$$\text{R.M.S. average} = \frac{\sqrt{h_1^2 + h_2^2 + h_3^2 + \dots + h_n^2}}{n}$$

### c. Ten point height method

The average difference between five highest peaks and five lowest valleys of surface is taken and irregularities are calculated by

$$S_2 = \frac{1}{5}(h_1 + h_2 + h_3 + h_4 + h_5) - (h_6 + h_7 + h_8 + h_9 + h_{10})$$

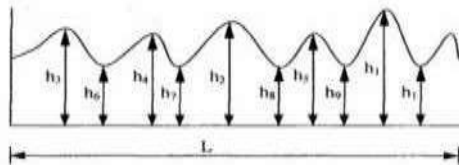

### 2. Peak to valley height method

Peak to valley height measures the maximum depth of the surface irregularities over a given sample length and largest value of the depth is accepted for the measurement.

Here,  $R$  = Maximum peak to valley height in one sampling lengths.  $R = \text{Maximum peak to valley height}$   
 $V = \text{Valley}$   $P = \text{Peak}$

Here,  $R$  is the maximum peak to valley height within the assessment length and the disadvantages of  $R$ , and is only a single peak or valley which gives the value is not a true picture of the actual profile of the surface

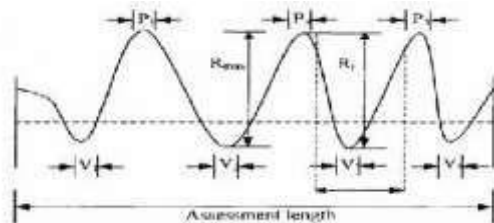

### 3. Form factor

It is obtained by measuring the area of material above the arbitrarily chosen base line in the section and the area of the enveloping rectangle.

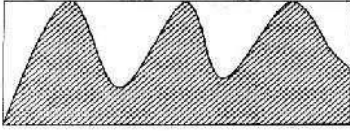

**Fig 3.23 Form factor**

$$\text{Degree of fullness } (F) = \frac{\text{Metal Area}}{\text{Enveloping rectangle Area}}$$

$$\text{Degree of emptiness, } (E) = 1 - F$$

### Methods of measuring surface finish

The methods used for measuring the surface finish is classified into

1. Inspection by comparison
2. Direct Instrument Measurements

#### 1. Inspection by comparison methods:

In these methods the surface texture is assessed by observation of the surface. The surface to be tested is compared with known value of roughness specimen and finished by similar machining process.

The various methods which are used for comparison are

1. Touch Inspection.
2. Visual Inspection.
3. Microscopic Inspection.
4. Scratch Inspection.
5. Micro Interferometer.
6. Surface photographs.
7. Reflected Light Intensity.
8. Wallace surface Dynamometer.

#### • Touch Inspection

It is used when surface roughness is very high and in this method the fingertip is moved along the surface at a speed of 25mm/second and the irregularities as up to 0.0125mm can be detected.

#### • Visual Inspection

In this method the surface is inspected by naked eye and this measurement is limited to rough surfaces.

#### • Microscopic Inspection

In this method finished surface is placed under the microscopic and compared with the surface under inspection. The light beam also used to check the finished surface by projecting the light about 60° to the work.

#### • Scratch Inspection:

The materials like lead, plastics rubbed on surface are inspected by this method. The impression of this scratches on the surface produced is then visualized.

#### • Micro-Interferometer

Optical flat is placed on the surface to be inspected and illuminated by a monochromatic source of light.

#### • Surface Photographs

Magnified photographs of the surface are taken with different types of illumination. The defects like irregularities appear as dark spots and flat portion of the surface appears as bright.

- **Reflected light Intensity**

A beam of light is projected on the surface to be inspected and the light intensity variation on the surface is measured by a photocell and this measured value is calibrated

- **Wallace surface Dynamometer:**

It consists of a pendulum in which the testing shoes are clamped to a bearing surface and a pre-determined spring pressure can be applied and then, The pendulum is lifted to its initial starting position and allowed to swing over the surface to be tested.

## 2. Direct instrument measurements

Direct methods enable to determine a numerical value of the surface finish of any surface. These methods are quantitative analysis methods and the output is used to operate recording or indicating instrument. Direct Instruments are operated by electrical principles. These instruments are classified into two types according to the operating principle. In this is operated by carrier-modulating principle and the other is operated by voltage-generating principle, and in the both types the output is amplified.

Some of the direct measurement instruments are

1. Stylus probe instruments.
2. Tomlinson surface meter.
3. Profilometer.
4. Taylor-Hobson Talysurf

### 1. Stylus probe type instrument Principle

When the stylus is moved over the surface which is to be measured, the irregularities in the surface texture are measured and it is used to assess the surface finish of the work piece.

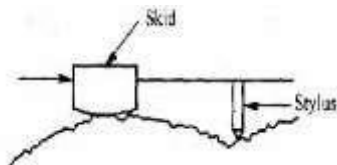

#### Working

The stylus type instruments consist of skid, stylus, amplifying device and recording device. The skid is slowly moved over the surface by hand or by motor drive. The skid follows the irregularities of the surface and the stylus moves along with skid. When the stylus moves vertically up and down and the stylus movements are magnified, amplified and recorded to produce a trace. Then it is analyzed by automatic device.

#### Advantage

Any desired roughness parameter can be recorded.

#### Disadvantages

1. Fragile material cannot be measured.
2. High Initial cost.
3. Skilled operators are needed to operate.

### 2. Tomlinson Surface meter

This instrument uses mechanical-cum-optical means for magnification.

## Construction

In this the diamond stylus on the surface finish recorder is held by spring pressure against the surface of a lapped cylinder. The lapped cylinder is supported one side by probe and other side by rollers. The stylus is also attached to the body of the instrument by a leaf spring and its height is adjustable to enable the diamond to be positioned and the light spring steel arm is attached to the lapped cylinder. The spring arm has a diamond scribe at the end and smoked glass is rest on the arm.

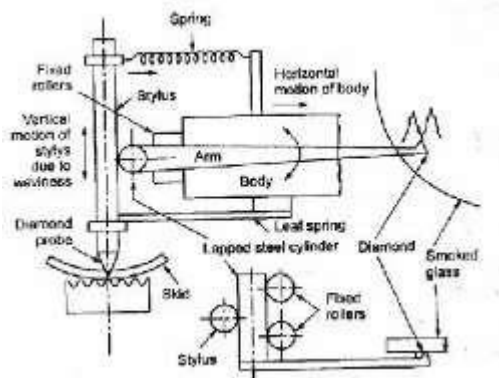

**Fig 3.24 Tomlinson Surface meter**

## Working

When measuring surface finish the body of the instrument is moved across the surface by a screw rotation. The vertical movement of the probe caused by the surface irregularities makes the horizontal lapped cylinder to roll. This rolling of lapped cylinder causes the movement of the arm. So this movement induces the diamond scribe on smoked glass. Finally the movement of scribe together with horizontal movement produces a trace on the smoked glass plate and this trace is magnified by an optical projector.

## 3. Profilometer

It is an indicating and recording instrument to measure roughness in microns. The main parts of the instrument are tracer and an amplifier. The stylus is mounted in the pickup and it consists of induction coil located in the magnet. When the stylus is moved on the surface to be tested, it is displaced up and down due to irregularities in the surface. This movement induces the induction coil to move in the direction of permanent magnet and produces a voltage. This is amplified and

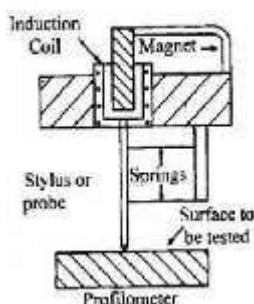

recorded.

**Fig 3.25 Profilometer**

## 4. Talyor-Hobson-Talysurf

It is working a carrier modulating principle and it is an accurate method comparing with the other methods. The main parts of this instrument is diamond stylus (0.002mm radius) and skid

## Principle

The irregularities of the surface are traced by the stylus and the movement of the stylus is converted into changes in

electric current.

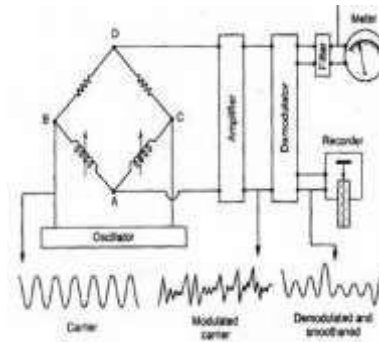
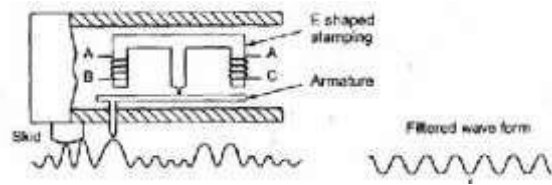

**Fig 3.26 Talyor-Honson Instrument**

### Working

On two legs of the E-shaped stamping there are coils for carrying an A.C. current and these coils form an oscillator. As the armature is pivoted about the central leg the movement of the stylus causes the air gap to vary and thus the amplitude is modulated. This modulation is again demodulated for the vertical displacement of the stylus. So this demodulated output is move the pen recorder to produce a numerical record and to make a direct numerical assessment.

### Straightness Measurement

A line is said to be straight over a given length, if the variation of the distance of its from two planes perpendicular to each other and parallel to the general direction of the line remains within the specified tolerance limits. The tolerance on the straightness of a line is defined as the maximum deviation in relation to the reference straight line joining the two extremities of the line to be checked.

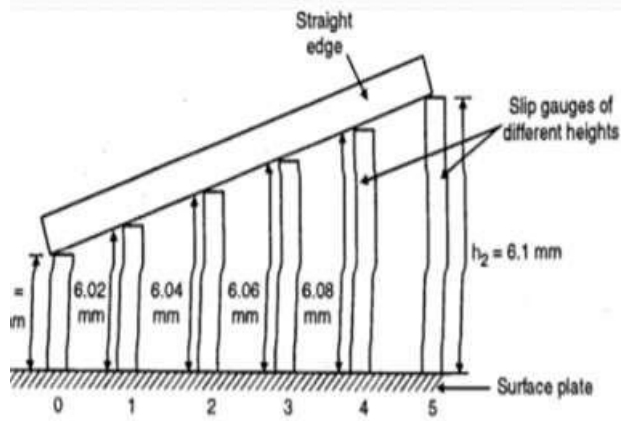

**Fig 3.27 Straightness Measurement**

### Straight edge

A straight edge is a measuring tool which consists of a length of a length of a steel of narrow and deep section in order to provide resistance to bending in the plane of measurement without excessive weight. For checking the straightness of any surface, the straight edge is placed over the surface and two are viewed against the light, which clearly indicate the straightness. The gap between the straight edge and surface will be negligibly small for perfect surfaces. Straightness is measured by observing the colour of light by diffraction while passing through the small gap. If the colour of light be red, it indicates a gap of 0.0012 to 0.0075mm. A more accurate method of finding the straightness by straight edges is to place it in equal slip gauges at the correct point for minimum deflection and to measure the uniformity of space under the straight edge with slip gauges.

### Test for straightness by using spirit level and Autocollimator

The straightness of any surface could be determined by either of these instruments by measuring the relative angular positions of number of adjacent sections of the surface to be tested. First straight line is drawn on the surface then it is divided into a number of sections the length of each section being equal to the length of spirit level base or the plane reflector's base in case of auto collimator. The bases of the spirit level block or reflector are fitted with two feet so that only feet have line contact with the surface and the surface of base does not touch the surface to be tested. The angular division obtained is between the specified two points. Length of each section must be equal to distance between the centerlines of two feet. The special level can be used only for the measurement of straightness of horizontal surfaces while auto-collimator can be used on surfaces are any plane. In case of spirit level, the block is moved along the line equal to the pitch distance between the centerline of the feet and the angular variation of the direction of block. Angular variation can be determined in terms of the difference of height between two points by knowing the least count of level and length of the base.

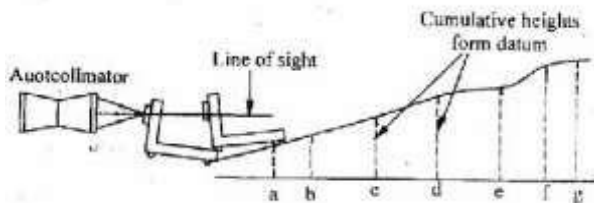

**Fig 3.28 Straightness using Auto-Collimator**

In case of autocollimator the instrument is placed at a distance of 0.5 to 0.75m from the surface to be tested. The parallel beam from the instrument is projected along the length of the surface to be tested. A block fixed on two feet and fitted with a plane vertical reflector is placed on the surface and the reflector face is facing the instrument. The image of the cross wires of the collimator appears nearer the center of the field and for the complete movement of reflector along the surface straight line the image of cross wires will appear in the field of eyepiece. The reflector is then moved to the other end of the surface in steps equal to. The center distance between the feet and the tilt of the reflector is noted down in second from the eyepiece.

### Flatness Testing

Flatness testing is possible by comparing the surface with an accurate surface. This method is suitable for small plates and not for large surfaces. Mathematically flatness error of a surface states that the departure from flatness is the minimum separation of a pair of parallel planes which will contain all points on the surface. The figure which shows that a surface can be considered to be composed of an infinitely large number of lines. The surface will be flat only if all the lines are straight and they lie in the same plane. In the case of rectangular table arc the lines are straight and parallel to the sides of the rectangle in both the perpendicular direction. Even it is not flat, but concave and convex along two diagonals. For verification, it is essential to measure the straightness of diagonals in addition to the lines parallel to the sides.

Thus the whole of the surface is divided by straight line. The fig, shows the surface is divided by straight line. The end line AB and AD etc are drawn away from the edges as the edges of the surface are not flat but get worn out by use and can fall off little in accuracy. The straightness of all these lines is determined and then those lines are related with each other in order to verify

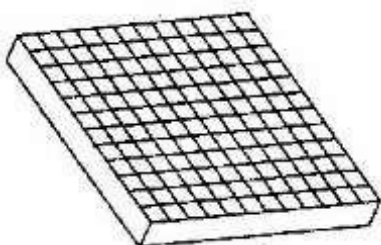





The measuring plungers are located 180° apart and the diameter is measured at several places. This method is suitable only when the specimen is elliptical or has an even number of lobes. Diametral check does not necessarily disclose effective size or roundness. This method is unreliable in determining roundness.

## 2. Circumferential confining gauge

Fig. shows the principle of this method. It is useful for inspection of roundness in production. This method requires highly accurate master for each size part to be measured. The clearance between part and gauge is critical to reliability. This technique does not allow for the measurement of other related geometric characteristics, such as concentricity, flatness of shoulders etc.

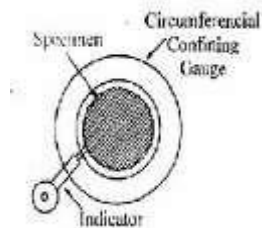

**Fig 3.30 Confining Gauge**

## Rotating on centers

The shaft is inspected for roundness while mounted on center. In this case, reliability is dependent on many factors like angle of centers, alignment of centres, roundness and surface condition of the centres and centre holes and run out of piece. Out of straightness of the part will cause a doubling run out effect and appear to be roundness error.

## 3. V-Block

The set up employed for assessing the circularity error by using V Block is shown in fig. The V block is placed on surface plate and the work to be checked is placed upon it. A diameter indicator is fixed in a stand and its feeler made to rest against the surface of the work. The work is rotated to measure the rise on fall of the workpiece. For determining the number of lobes on the work piece, the work piece is first tested in a 60° V-Block and then in a 90° V-Block. The number of lobes is then equal to the number of times the indicator pointer deflects through 360° rotation of the work

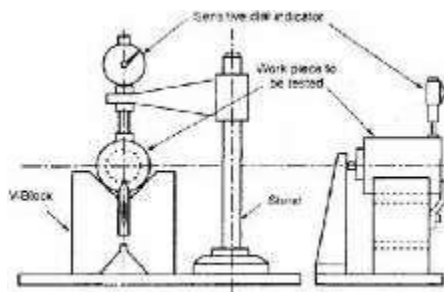

piece.

**Fig 3.31 V-Block**

## Limitations

- a) The circularity error is greatly affected by the following factors.
  - (i) If the circularity error is  $\lambda$ , then it is possible that the indicator shows no variation.
  - (ii) Position of the instrument i.e. whether measured from top or bottom.

(iii) Number of lobes on the rotating part.

b) The instrument position should be in the same vertical plane as the point of contact of the part with the V-block.

c) A leaf spring should always be kept below the indicator plunger and the surface of the part.

#### 4. Three point probe

The fig. shows three probes with  $120^\circ$  spacing is very useful for determining effective size they perform like a  $60^\circ$  V-block.  $60^\circ$  V-block will show no error for 5 or 7 lobes magnify the error for 3-lobed parts show partial error for randomly spaced lobes.

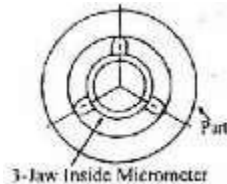

**Fig 3.32 Three Point Probe**

#### Roundness measuring spindle

There are following two types of spindles used.

##### 1. Overhead spindle

Part is fixed in a staging plat form and the overhead spindle carrying the comparator rotates separately from the part. It can determine roundness as well as camming (Circular flatness). Height of the work piece is limited by the location of overhead spindle. The concentricity can be checked by extending the indicator from the spindle and thus the range of this check is limited.

##### 2. Rotating table

Spindle is integral with the table and rotates along with it. The part is placed over the spindle and rotates past a fixed comparator

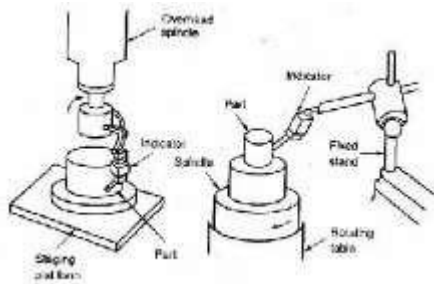

**Fig 3.32 Rotating Table**

#### Roundness measuring machine

Roundness is the property of a surface of revolution, where all points on the surface are equidistant from the axis. The roundness of any profile can be specified only when same center is found from which to make the measurements. The diameter and roundness are measured by different method and instruments. For measurement of diameter it is done statically, for measuring roundness, rotation is always necessary.

Roundness measuring instruments are two types.

1. Rotating pick up type.
2. Turn table type

weight of the work piece, being stationary and is easy to make. In the turn table type the pickup is not associated with the spindle. This is easier to measure roundness. Reposition the pickup has no effects on the reference axis.

The pickup converts the circuit movement of the stylus into electrical signal, which is processed and amplified and fed to a polar recorder. A microcomputer is incorporated with integral visual display unit and system is controlled from compact keyboards, which increases the system versatility, scope and speed of analysis. System is programmed to assess the roundness of work piece with respect to any four of the internationally recognized reference circles. A visual display of work piece profile can be obtained. Work piece can be assessed over a circumference, and with undercut surface or an interrupted surface with sufficient data the reference circle can be fitted to the profile. The program also provides functions like auto centering, auto ranging, auto calibration and concentricity.

### **Modern Roundness Measuring Instruments**

This is based on use of microprocessor to provide measurements of roundness quickly and in a simple way; there is no need of assessing out of roundness. Machine can do centering automatically and calculate roundness and concentricity, straightness and provide visual and digital displays. A computer is used to speed up calculations and provide the standard reference circle.

#### **(i) Least square circle**

The sum of the squares of a sufficient no. of equally spaced radial ordinates measured from the circle to the profile has minimum value. The center of such circle is referred to as the least square center. Out of roundness is defined as the radial distance of the maximum peak from the circle (P) plus the distance of the maximum valley from this circle.

#### **(ii) Minimum zone or Minimum radial separation circle**

These are two concentric circles. The value of the out of roundness is the radial distance between the two circles. The center of such a circle is termed as the minimum zone center. These circles can be found by using a template.

#### **(iii) Maximum inscribed circle**

This is the largest circle. Its center and radius can be found by trial and error by compare or by template or computer. Since  $V = 0$  there is no valleys inside the circle.

#### **(iv) Minimum circumscribed circles**

This is the smallest circle. Its center and radius can be found by the previous method since  $P = 0$  there is no peak outside the circle. The radial distance between the minimum circumscribing circle and the maximum inscribing circle is the measure of the error circularity. The fig shows the trace produced by a recording instrument.

This trace to draw concentric circles on the polar graph which pass through the maximum and minimum points in such way that the radial distance between minimum circumscribing circle containing the trace or the maximum inscribing circle which can be fitted into the trace is minimum. The radial distance between the outer and inner circle is minimum is considered for determining the circularity error. Assessment of roundness can be done by templates. The out of roundness is defined as radial distance of the maximum peak (P) from the least square circle plus the distance of maximum valley (V) from the least square circle. All roundness analysis can be performed by harmonic and slope analysis.