

SNS COLLEGE OF ENGINEERING

Kurumbapalayam (Po), Coimbatore – 641 107

AN AUTONOMOUS INSTITUTION



Accredited by NBA–AICTE and Accredited by NAAC–UGC with ‘A’ Grade
Approved by AICTE, New Delhi & Affiliated to Anna University, Chennai

I SEMESTER

19ME102

BASIC CIVIL AND MECHANICAL ENGINEERING

(Common to Circuit Branches)

L T P C
3 0 0 3

Course Objectives

1.	To know the various Civil Engineering Materials and concepts of surveying
2.	To know Components of Buildings
3.	To be familiar with the applications of various types of Power Plants
4.	To know the working principle of IC Engines, Refrigeration and Air conditioning Systems
5.	To learn basic Manufacturing process

Program Outcomes (POs)

PO-4	Conduct investigations of complex problems: Use research-based knowledge and research methods including design of experiments, analysis and interpretation of data, and synthesis of the information to provide valid conclusions.
PO-6	The engineer and society: Apply reasoning informed by the contextual knowledge to assess societal, health, safety, legal and cultural issues and the consequent responsibilities relevant to the professional engineering practice.

Course Outcomes (COs)

At the end of the course students should be able to

1.	Understand the concepts of surveying and usage of building materials
2.	Explain the usage of building components
3.	Identify the components used in power plant
4.	Elaborate the components of IC engines, refrigeration and air conditioning.
5.	Demonstrate basic manufacturing process such as casting and welding.

Mapping of CO with PO

CO No	PO1	PO2	PO3	PO4	PO5	PO6	PO7	PO8	PO9	PO10	PO11	PO12	PSO1	PSO2
1				1		2								
2				1		2								
3				1		2								
4				1		2								
5				1		2								

UNIT-I CIVIL ENGINEERING MATERIALS AND SURVEYING	11
Introduction: Civil engineering-scope of civil engineering-building materials- Brick, stone, cement, concrete, properties-uses Surveying: Objects – types – classification – principles-measurements of distances – angles – Concepts of leveling – determination of areas – illustrative examples.	
UNIT-II BUILDING COMPONENTS	10
Sub Structure: Types of foundation - Bearing capacity – Requirement of good foundations. Superstructure: Types of structure - Types of masonry – beams – columns – lintels – roofing- flooring – plastering.	
UNIT-III POWER PLANT ENGINEERING	8
Introduction, Classification of Power Plants – Working principle of steam, Gas, Diesel, Hydro- electric, Nuclear and Solar Power plants – Merits and Demerits – working principle of Pumps -Single, Double acting and Centrifugal Pumps.	
UNIT-IV IC ENGINES, REFRIGERATION AND AIR CONDITIONING SYSTEM	8
Internal combustion engines as automobile power plant – Working principle of Petrol and Diesel Engines – Four stroke and two stroke cycles -Principle of Vapour compression system – Layout of typical domestic refrigerator – Window and Split type room Air conditioner	
UNIT-V BASIC MANUFACTURING PROCESSES	8
<p>Foundry: Introduction- patterns – moulding –casting - cupola furnace.</p> <p>Welding: Introduction-Classification – ARC, TIG, MIG welding, Gas welding, soldering and brazing.</p> <p>Machining process: Introduction-Classification – lathe and drilling machines.</p>	

TOTAL : 45 PERIODS

TEXT BOOKS

1.	Naveen Sait.A., Soundararajan.R., “Basic Civil and Mechanical Engineering”, RPPublications, Coimbatore, (2017).
2.	Venugopal K and Prahu Raja V, “Basic Mechanical Engineering”,AnuradhaPublishers, Kumbakonam, (2017).

REFERENCE BOOKS

1.	Shanmugam G and Palanichamy M S, “Basic Civil and Mechanical Engineering”,Tata McGraw Hill Publishing Co., New Delhi, (2017).
2.	Rangwala,S.C., “ Engineering Materials” , Charotar Publishing House, Anand, 2016.
3.	Surendra Singh, “Building Materials” Vikas Publishing Company, New Delhi, 2016.
4.	Hibbeller, R.C., “Engineering Mechanics”, 14th edition, Prentice hall (2016).
5.	Rao, P N, —Manufacturing Technology: Foundry, Forming And Welding”, Tata McGraw-Hill, New Delhi, 2016.

WEB RESOURCES

1.	https://nptel.ac.in/courses/105102088/
2.	https://nptel.ac.in/courses/112107216/

TABLE OF CONTENTS

S.NO	TITLE	PAGE NO
1	SURVEYING AND CIVIL ENGINEERING MATERIALS	1
	1.1 Surveying	1
	1.1.1 object of surveying	1
	1.1.2 Primary divisions of surveying	1
	1.1.3 Principle of surveying	1
	1.1.4 Classification of surveying:	2
	1.1.4.1 Instruments used for chain surveying:	2
	1.1.4.2 Principle of Chain Surveying	3
	1.1.4.3 Advantages and Disadvantages of chain surveying	4
	1.1.5 Calculation of Areas from offsets to a Base line	4
	1.1.6 Compass survey	5
	1.1.6.1 Methods of using prismatic compass	6
	1.1.6.2 bearing of line	6
	1.1.6.3 Designation of bearing	7
	1.1.6.4 Fore bearing and back bearing	7
	1.1.7 Theodolite survey	8
	1.1.8 Leveling	9
	1.1.8.1 Principle of leveling	10
	1.1.8.2 reduction level	10
	1.1.9.1 Methods of plane table survey	11

1.1.10 Stones	11
1.1.2 Properties of Stones	13
1.1.10.2 Requirements of Good Building Stones	14
1.1.10.3 Tests on Stones	15
1.1.10.4 Uses of stones	15
1.1.11 Bricks	16
1.1.11.1 Properties of Bricks	16
1.1.11.2 Tests on Bricks	18
1.1.11.3 Classification of Bricks Based on their Quality	20
1.1.11.4 Uses of Bricks	20
1.1.12 Cement	20
1.1.12.1 Types of Cement	21
1.1.12.2 Properties of Ordinary Portland Cement	22
1.1.12.3 Uses of cement	23
1.1.13 Sand	23
1.1.13 Plain concrete	24
1.1.13.1 Properties of green concrete	25
1.1.13.2 Tests on Concrete	26
1.1.14 Ferrous metal	31
2 BUILDING COMPONENTS AND STRUCTURES	32
2.1 Introduction	32

2.1.1 Elements of building	32
2.1.1.2 Basic requirements of a building	35
2.1.1.3 Planning	36
2.1.1.5 Planning for energy efficiency	39
2.1.1.6 Planning for suitable utility	39
2.1.1.7 Planning for meeting other requirements	40
2.2 Conventional spread footings	40
2.2.2 R.C.C. footings	41
2.2.2.1 Grillage footing	44
2.2.3 Arch foundation	45
2.2.4 Pile foundations	45
2.2.5 Stone masonry	48
2.6 Brick masonry	51
2.7 Beams	54
2.8 Columns	55
2.9 Lintels	57
3.0 Flooring	59
3.1 Upper floor	61
3.1.1 Roof Coverings for Pitched	70
3.1.1 Roof Coverings for Pitched	70
3.2 Plastering	72

	3.3 Stress and strain	72
	3.3.1 Types of stresses and strains	72
	3.4 Elasticity	74
	3.4.1 Elastic limit	74
	3.4.2 Hooke's law	74
	3.4.3 Young's Modulus	74
	3.4.4 Shear modulus	74
	3.4.5 Bulk Modulus	74
	3.4.6 Poisson's ratio	74
	3.4.7 Relation between elastic constants	75
	3.4.8 Factor of safety	75
	3.5 Bridges	76
	3.5.1 Classification of bridges	75
5	3.5.2 Component parts of a bridge	77
	5 3.6 Dams	80
	3.6.1 Introduction	80
	3.6.2 Purpose of a dam	80
	3.6.3 Factors governing selection of site for dam	81
	3.6.4 Classification of dams	83
		86
	3.7 Basics of interior design	

UNIT 3 POWER PLANT ENGINEERING

3.1	Classification Of Power Plants	89
3.2	Layout Of Steam Power Plant	89
3.2.1	Coal And Ash Circuit	89
3.2.2	Air And Flue Gas Circuit	90
3.2.3	Water And Steam Circuit	91
3.2.4	Cooling Water Circuit	91
3.3	Selection Of Site For Thermal Power Plan	93
3.4	Gas Power Plant	94
3.5	Diesel Power Plant	97
3.5.1	Working Of Diesel Power Plant:	97
3.5.2	Main Components Of A Diesel	98
3.6	Hydro Electric Power Plant	98
3.6.1	Components Of Hydro Electric Power Plant	98
3.6.2	Working Principle Of Hydro Electric Power Plant	100
3.6.3	Classification Of Hydro Electric Power Plant	101
3.7	Nuclear Power Plant	102
3.7.1	Components Of Nuclear Power Plant	104
3.7.2	Working Principle Of Nuclear Power Plant	105
3.8	Pumps	106
3.8.1	Classification Of Pumps	107
3.8.2	Reciprocating Pumps	107
3.8.3	Working Of Single Acting Reciprocating Pump	107
3.8.4	Double Acting Reciprocating Pump	107
3.9	Air Vessels	108
3.9.1	purpose Of Using An Air Vessel	108
3.10	Centrifugal Pumps	109
3.10.1	Components Of Centrifugal Pump	109
3.10.2	Working Principle Of Centrifugal Pump	109
3.11	Impulse Turbine	112
3.12	Reaction Turbine	112
3.12.1	Comparison Between Impulse And Reaction Turbine	112

UNIT 4 INTERNAL COMBUSTION ENGINES

4.1	Introduction	113
4.2	Classification Of Heat Engines	113
4.3	Main Components Of IC Engines	113
4.4	Main Components Of IC Engine	116
4.5	Petrol Engines	118
4.5.1	Two Stroke Cycle Petrol Engines	119
4.5.2	Two Stroke Cycle Diesel Engines- Construction	120
4.5.3	Four Stroke Cycle Petrol Engines	122
4.5.4	Four Stroke Diesel Engine	122
4.6	Scavenging	123
4.7	Comparison Between Si And Ci Engines (General Comparison)	123
4.8	Comparison Between Si And Ci Engines (Merits And Demerits)	123
4.9	Comparison Between Four Stroke Cycle And Two Stroke Cycle Engine (Merits And Demerits)	124
4.10	Comparison Between Four Stroke Cycle And Two Stroke Cycle Engine (Merits And Demerits)	125
4.11	I.C Engine Terminology	125

4.11.1	Major Parts Of An Ic Engine	126
4.12	Steam Boilers	127
4.12.1	Fire Tube & Water Tube Boilers	127
4.12.2	Internally Fired Boiler	128
4.12.3	Externally Fired Boiler	129
4.12.4	Cochran Boiler	129
4.12.5	Lamont Boiler	130
4.13	Boiler Mountings & Accessories	130
4.14	Boiler Accessories	131
4.15	Differences Between Boiler Mountings And Accessories:	134

UNIT 5 REFRIGERATION AND AIRCONDITIONING

5.1	Refrigeration	137
5.2	Vapour Compression Refrigeration System	138
5.3	Vapour Absorption Refrigeration System	140
5.4	Comparison Between Vapour Compression & Vapour Absorption Refrigeration Systems	140
5.5	Air Conditioning	143
5.6	Classification Of Air Conditioning	143
5.7	Window Type Air Conditioner	144
	Question Bank	147
	University question	154

UNIT I**SURVEYING AND CIVIL ENGINEERING MATERIALS**

Surveying: Objects – types – classification – principles – measurements of distances – angles – leveling – determination of areas – illustrative examples.

Civil Engineering Materials: Bricks – stones – sand – cement – concrete – steel sections

1.1 Surveying

Surveying is the art of determining the relative position of points on above or beneath the surface of the earth by means of direct or indirect measurements of distances, direction and elevation.

1.1.1 Object of surveying

The primary object of a survey is the preparation of a plan map. The results of surveys when plotted and drawn on paper, constitute a plan. Therefore a plan is a representation of the ground and the objects upon it some scale as projected on a horizontal plane. If the scale is large, then it is called a plan. If the scale is small, then it is called a map. Example: a plan of a building, a map of India.

Purposes of survey

Following are some of the purposes of survey:

- ✓ To prepare archeological maps, geological maps, military maps etc.
- ✓ To establish boundary points of properties with reference to the available records and demarcate ownership.
- ✓ To measure quantities in cutting or in embankments using contour maps.
- ✓ To lay out the alignment of engineering structures such as roads, railways etc.
- ✓ To plot profile of a structure (eg. irrigation canal) for ascertaining the carrying capacity of canal, capacity of reservoir etc
- ✓ To determine the relative position of desired points with reference to a known bench mark (eg. position of hill stations with reference to mean sea level).
- ✓ To measure distance between various points (eg. distance between two cities).

1.1.2 Primary divisions of surveying

Survey may be primarily divided into following two divisions.

- ✓ Plane surveying: in plane surveying, the mean surface of the earth is considered as a plane and the spheroid shape is neglected as the surveys extend over small areas.
- ✓ Geodetic surveying: in geodetic surveying, the curvature of earth is taken into account and all lying in the surface are curved lines and the triangles are spherical triangles, since large distances and areas are covered.

1.1.3 Principle of surveying

All surveys are based on two fundamental principles they are:

- ✓ Working from whole to part: in order to prevent accumulation of errors and to localize the minor errors, a set of primary central points are established first with higher precision in and around the area to be surveyed. Later on, in between those primary control points, inner control points are established with less precision method. The details are surveyed with the help of these inner control points, adopting any one method of surveying. This principle is known as working from whole to part.
- ✓ Fixing a point with reference to two fixed points: suppose points 'A' and 'B' are known on the distance between them is measured

- ✓ . Let it be required to locate or mark a point 'C'. The relative position of the point C is located with reference to the two fixed points A and B by one of the following methods.

- a) Liner measurement
- b) Angular measurement
- c) Both liner and angular measurements

1.1.4 Classification of surveying:

According to the instruments used, the surveying is classified as follows:

- ✓ chain surveying
- ✓ compass surveying
- ✓ theodolite surveying
- ✓ plane table surveying
- ✓ tachometric surveying etc.

1.1.4.1 Instruments used for chain surveying:

The various instruments used in chain surveying are as follows.

- ✓ chain
- ✓ arrows
- ✓ pegs
- ✓ ranging rods
- ✓ offset rods
- ✓ plumb bob

1. Chain:

Chains are used to measure horizontal distances. Chains are formed of straight links of galvanized mild steel wire called links. The ends of each link are bent into a loop and connected together by means of three oval rings which afford flexibility to the chain.

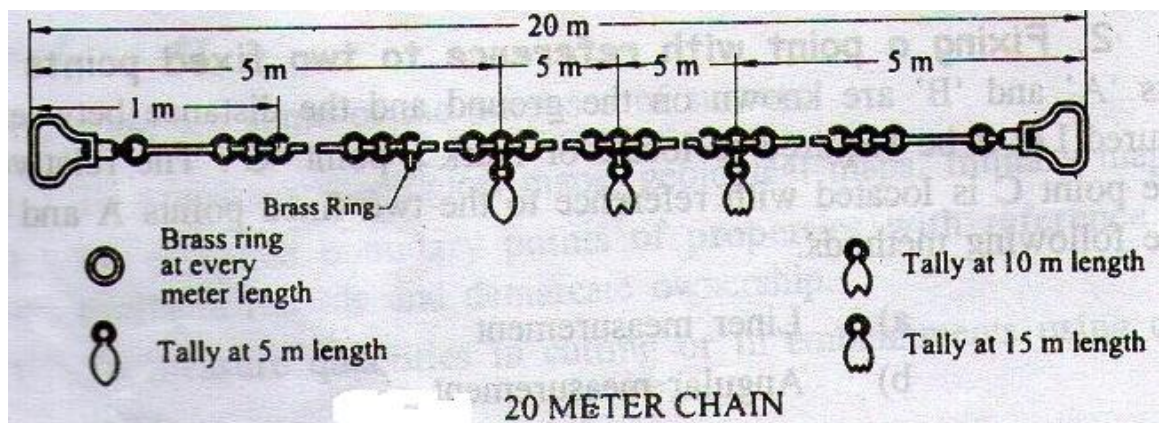

The chain is made of mild steel. The ends of the chain are provided with brass handles for dragging the chain on the ground. The outside of the handle is the zero point or the end point of the chain and the length of the chain measured from the outside of one handle to the outside of the other. The length of a link is the distance between the centers of the two consecutive middle rings.

The end links include the handles. Metallic tags are indicators of the chain to facilitate quick reading of fraction of a chain in surveying measurements. Metric survey chains are available in lengths of 20m and 30m. The 20m chain contains 100 links whereas 30m. Chain contains 150 links. One link of both the type of chain measure 20cm.

2. Arrows:

Arrows or making pins are made of tempered steel wire 4mm in diameter and generally 10 arrows are supplied with a chain. An arrow is inserted into the ground after the chain length is measured on the ground. Usually the length of an arrow is 40cm and one end of it is made sharp and the other end is bent into a circle for facility of carrying.

3. Pegs:

Wooden pegs are used to mark the positions of the stations terminal points of a survey line. They are made of hard timber, generally 2.5cm or 3 cm square and 15cm long, tapered at the end.

4. Ranging Rods

The ranging rods are used for making the positions of stations and for ranging the lines. They are made of ell seasoned straight grained timber teak. They circular in cross section of 3cm diameter and have a length of either 2 or 3m, length being more common. They are shod at the bottom with a heavy iron points. In order to make them visible at a distance, they are painted alternatively black and white or red and white.

5. Offset

Offset rod is similar to that of ranging rod. They are should with pointed iron shoe at one end, ad provided with a notch or a hook at the other for pulling or pushing the chain through a hedges or other obstructions.

6. Plumb Bob

While chaining along sloping ground, a plumb is required to transfer the points to the ground. It is also used for accurate centering of the theodolite compass, plane table etc over a station mark and for testing the vertically of ranging poles

7. Cross staff

This is the instrument used for setting out right angles to a chain line. It consists of either a frame or box with two pairs of vertical slits and is mounted on a pole shod for fixing in the ground

- ✓ Open cross staff
- ✓ French cross staff
- ✓ Adjustable cross staff

1.1.4.2 Principle of Chain Surveying

The rectangle is the simplest fig that can be plotted from the lengths of its sided. Based on this, the principle of chain surveying is to divide the area to be surveyed into a network of connected triangles. Hence chain surveying is some times called chain triangulation. The exact arrangement of triangles to be adopted depends upon the shape and configuration of the ground and obstacles met with. When it contains no angle smaller than 30degree greater than 120 degree.

1.1.4.3 Advantages and Disadvantages of chain surveying**Advantages:**

- ✓ Chain surveying is suitable for fairly level ground
- ✓ It does not require costly equipments
- ✓ It is used for preparing plans of smaller area
- ✓ It is simple

Disadvantages

- ✓ It is cannot used for large areas
- ✓ It is not always accurate

1.1.5 Calculation of Areas from offsets to a Base line**The area may be calculated by the rule:**

- ✓ Mid-ordinate Rule
- ✓ Average ordinate Rule
- ✓ Trapezoidal rule
- ✓ Simpson's Rule

1. Mid-ordinate rule:

$$\text{Area} = (O_1 + O_2 + \dots + O_n)d$$

O_1, O_2 = the ordinates at the mid points of each division

n = number of divisions

L = Length of base line = nd

d = Distance of each division

2. Average ordinate Rule

$$\text{Area} = ((O_1 + O_2 + \dots + O_n)/(n+1))L$$

O_1, O_2, \dots = Ordinates at the end of each division

3. Trapezoidal Rule

$$\text{Area} = (((O_0 + O_n)/2) + (O_0 + O_2 + \dots + O_{n-1}))d$$

4. Simpson's Rule

$$\text{Area} = ((d/3) \times ((O_0 + O_n) + 4(O_1 + O_3 + O_{n-1}) + 2(O_2 + O_4 + \dots + O_{n-2})))$$

Example: 1

The following perpendicular offsets were taken at 10 meter intervals from a survey line to an irregular boundary line.

3.15m, 4.3m, 8.2m, 5.6m, 6.85m, 7.6m, 4.2m, 5.6m, 4.3m

Calculate the area enclosed between the survey line, the irregular boundary line, and first and last offsets, by the application of

- a) Average ordinate rule
- b) Trapezoidal rule
- c) Simpson's rule

Average

d = the interval between the offset = 10 m

n = number of divisions = 8

n+1 = number of ordinates = 8+1 =9

L= Length of the base line = 8 x 10 = 80m

a) Average ordinate rule

$$\text{Area} = ((O_1+O_2+\dots+O_n)/(n+1))L$$

O₁, O₂...= Ordinates at the end of each division

$$\begin{aligned} \text{Area} &= ((3.15 + 4.3 + 8.2 + 5.6 + 6.85 + 7.6 + 4.2 + 5.6 + 4.3)/(8+1)) \times 80 \\ &= 442.66\text{m}^2 \end{aligned}$$

b) Trapezoidal rule

$$\text{Area} = (((O_0+O_n)/2) + (O_0+O_2+\dots+O_{n-1}))d$$

$$\text{Area} = (3.725 + 42.35) \times 10 = 460.75\text{m}^2$$

c) Simpson's rule

$$\text{Area} = 10/3(7.45 + 92.4 + 38.5) = 461.167\text{m}^2$$

1.1.6 Compass survey

When the area to be surveyed is large, chain and compass surveying is preferable. A compass is used to measure the magnetic bearing of a line. There are two forms of compass that are commonly used. 1. The prismatic compass and 2. The surveyors' compass.

1. The prismatic compass: It is circular in shape and its diameter varies from 85 mm to 110 mm. A pivot is provided at the centre of the box. It carries a magnetic needle. The needle is attached to an aluminum ring which is graduated to 1/2. A light spring break is attached to the inside of the base to damp the oscillations of the needle and bring it to rest before taking a reading.

A reflecting prism facilitates reading of the angles and is protected from moisture and dust etc by a prism cap. The prism base and vertical faces are made convex which magnifies the readings. The object vane is located diametrically opposite to the prism. It is hinged to the side of the box and carries a horse hair. A tilted reflecting mirror is provided on the side of the object vane to enable bearing of very high or low objects to be taken. A metal cover is provided to enclose the compass and the object vane.

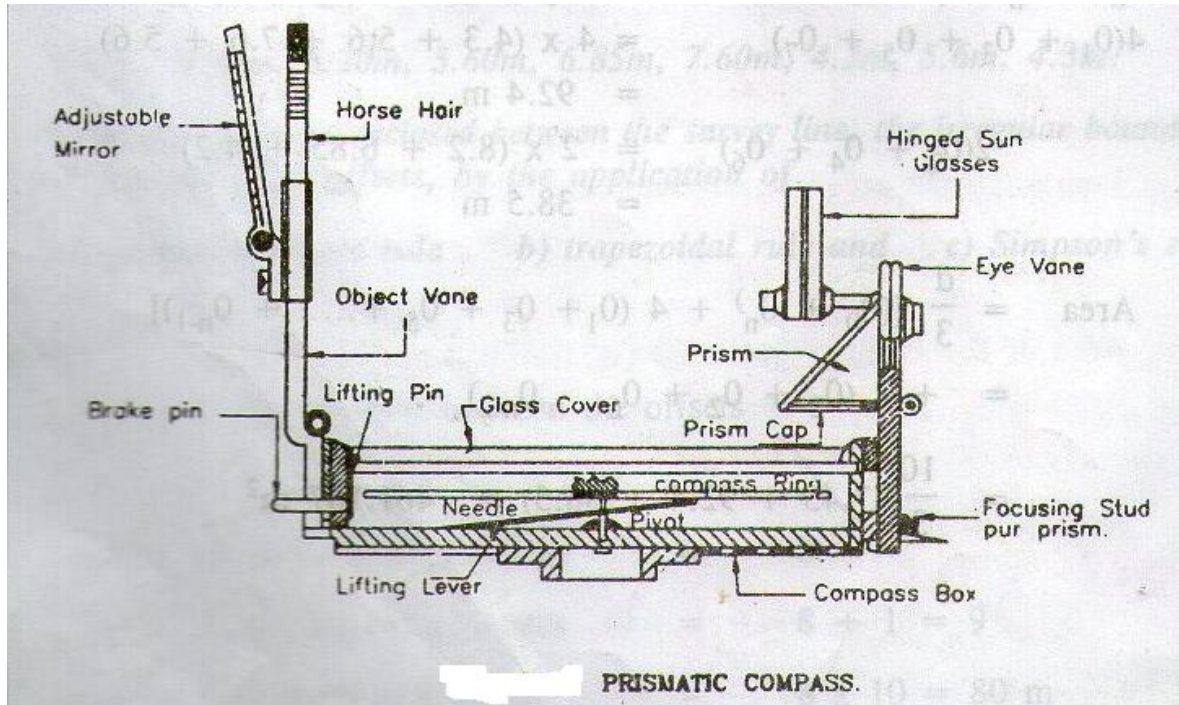

2. Surveyor's compass: Surveyor's compass resembles the prismatic compass but with a slight difference. The graduated card is attached to the box and North 90 at south and at East and West interchanged

1.1.6.1 Methods of using prismatic compass

The compass is usually mounted on a light tripod which carries a vertical spindle in a ball and socket joint which the box is screwed. By means of this arrangement, the instrument can be quickly leveled and also rotated in a horizontal plane and clamped in any position.

Centering: The compass should be centered over the station where the bearing is to be taken. This is done by dropping a small piece of stone from the centre of the compass so that it falls on the top of the peg marking the station (or by using plumb bob) and by adjusting the legs of the tripod.

Leveling : The compass should then be leveled by eye, by means of a ball and socket joint so that the graduated ring may swing quite freely. It should be clamped when leveled.

Observing Bearing: A ranging rod is kept at the next station.

The compass is turned until the ranging rod at the station is bisected by the hair when looked through the slit above the prism.

When the needle comes to rest, by pressing the knob if necessary, the reading is noted at which the hair line appears to cut the image of the graduated ring. The sighting of the ranging rod and the reading is done simultaneously. The reading gives the bearing of the line.

1.1.6.2 bearing of line:

The bearing of a line is the horizontal angle made by the line with a selected reference line called the meridian. There are two types of bearings.

i) Magnetic Bearing: The direction indicated by a freely supported magnetic needle unaffected by local attractive forces, is called the magnetic meridian. The angle between any line and magnetic meridian is called magnetic bearing or simply bearing.

ii) The Bearing: The line joining the geographical north and south poles is known as the

true meridian or geographical meridian. The angle between any line and the true meridian is called true bearing or azimuth.

1.1.6.3 DESIGNATION OF BEARING

- ✓ The whole circle bearing system
- ✓ Quadrantal bearing system, or reduced bearing system

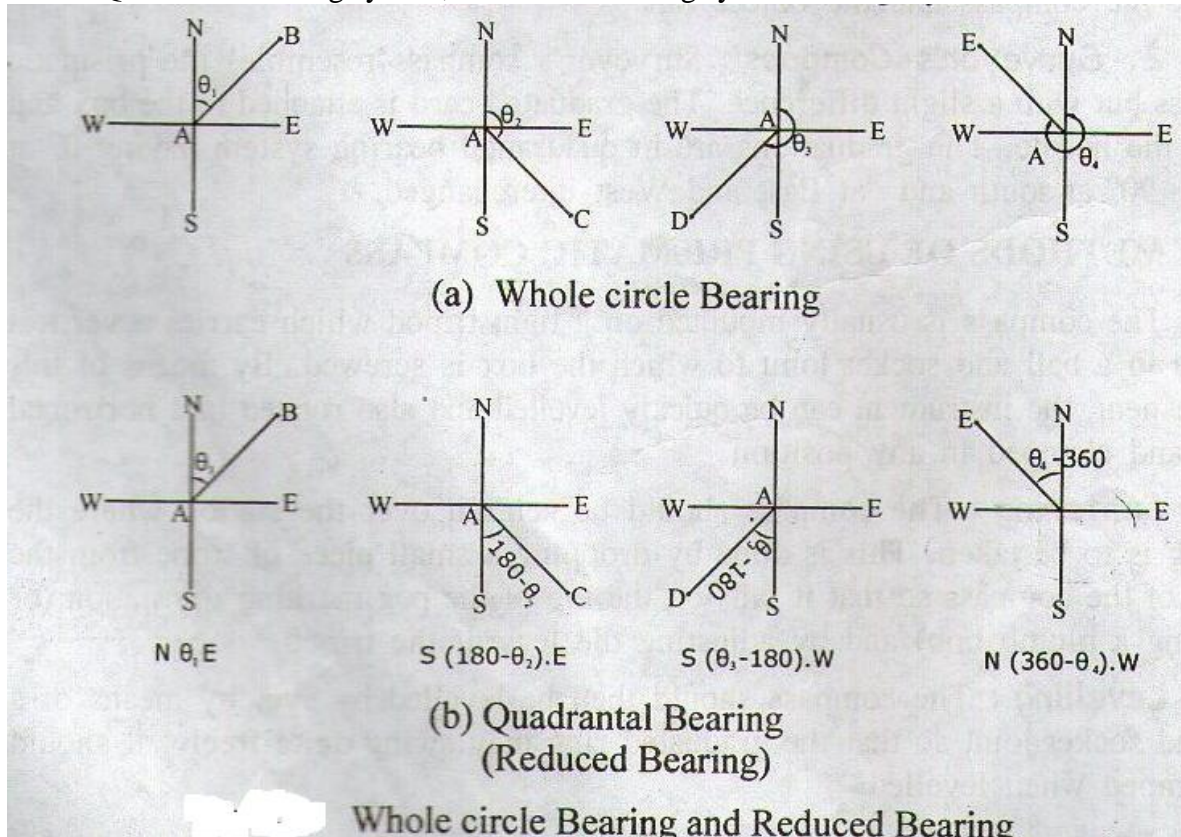

✓ The whole circle bearing system:

In this system the bearing of a line is measured with north in clockwise direction. The value of the bearing thus varies from 0° to 360° .

✓ Quadrantal bearing system

In this system the bearing of a line measured from either the north or the south, clockwise or counter clockwise whichever is nearer the line, towards the east or west

1.1.6.4 Fore bearing and back bearing

In compass surveying, two bearings are observed for each line, one from each end of the line. The bearing of a line in the direction of the progress of survey is called fore bearing while the bearing measured in the opposite direction is known as back bearing. For e.g. the bearing of line AB taken from the point A is the fore bearing of line AB and the bearing from point B is back bearing of the line AB.

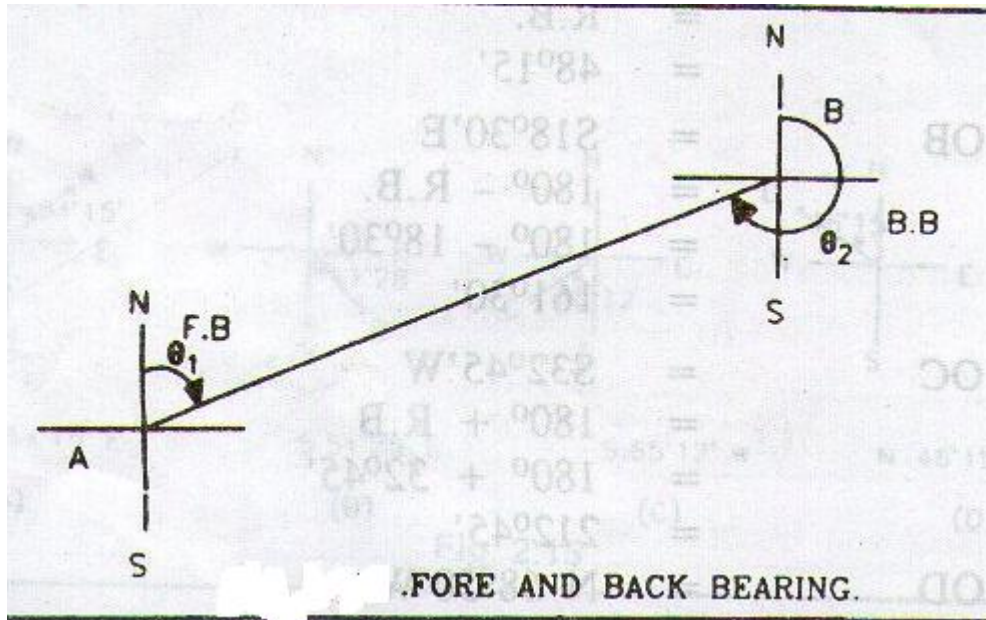

1.1.7 Theodolite survey

The theodolite is the most precise instrument used for measurement of horizontal and vertical angles. It can also be used for various surveying operations such as establishing grades, setting out curves, extending survey lines, determining differences in elevation etc.

Two categories classified:

- ✓ Transit theodolite
- ✓ Non-transit theodolite

Essential parts of a transit theodolite

Telescope:

A theodolite is provided with a telescope to sight the distant objects clearly. It is mounted on a spindle known as horizontal axis

Two spindles:

There are two spindles with axes one inside the other. The outer axis is hollowed and its interior is ground conical to fit the central vertical axis which is a solid and conical.

Lower plate:

The outer axis is attached to the lower plate also called the scale plate, having its edge beveled. The edge is silvered and graduated from 0° to 360° in the clockwise direction. The lower plate is provided with a clamped tangent screw or the slow motion screw by means of which it can be fixed at any desired position

Upper plate:

The upper plate also called the vernier plate is attached to the inner axis. A clamp and a tangent or slow motion screw are provided for the purpose of accurately fixing the vernier plate to the scale plate. When both plates are clamped together and the lower clamp or loosened, the instrument can be rotated about its outer axis; while if lower plate be clamped and the vernier plate be loosened, the instrument can be rotated about the inner axis. Before either of the tangent screw is turned, the corresponding clamp must be tightened.

Level Tubes:

Two spirit levels called placed at right angles to each other are fixed on the upper surface of the vernier plate for leveling in the instrument.

Vertical circle:

The vertical circle is graduated and is attached to the horizontal axis of the telescope and thus it rotates with the telescope. The circle is graduated either continuous from 0° to 90°. By means of vertical clamp and tangential screw, the telescope can be set accurately at any position in vertical plane.

1.1.8 Levelling

Levelling may be defined as the art of determining the relative height or elevations of points or objects on the earth's surface.

Instruments used for leveling:

- ✓ Level
- ✓ Levelling Staff

Level: The purpose of a level is to provide a horizontal line of sight.

Parts:

- ✓ A telescope to provide line of sight
- ✓ A level tube to make the line of sight horizontal
- ✓ A leveling head to bring the bubble in its centre of run
- ✓ A tripod to support the instrument

Dumpy level:

The telescope is rigidly fixed with the support and therefore, can neither be rotated about the longitudinal axis, nor can it be removed from its support. A long bubble tube is attached to the top of the telescope. The leveling head generally consists of two parallel plates with either three foot screws or four foot screws. The upper plate is known as tribrach and the lower plate is known as trivet which can be screwed on a tripod.

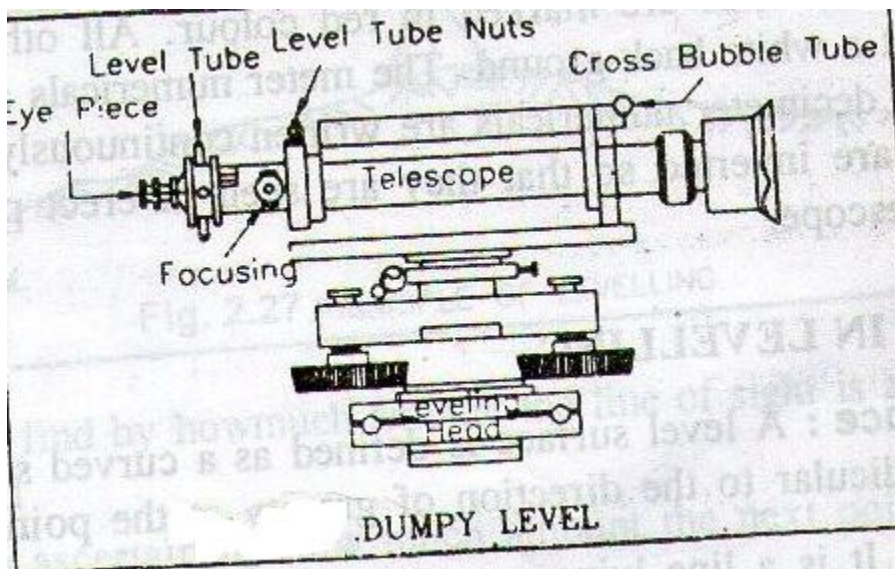

Levelling staff:

A leveling Staff is a straight rectangular rod having graduations, the foot of the staff representing zero reading. There are various type of graduated staff available and only one type is described here.

Folding type of 4m Levelling Staff:

It consists of two wooden pieces each of 2m of length with the joint assembly. The thickness and width of staff are respectively 18mm and 75mm. The folding joint is of the detachable type with locking device at the back.

Hence the staff can be made into two parts for easy handling. When two pieces are locked together, the two pieces form a straight rigid leveling staff of length equal to 4m.

1.1.8.1 Principle of leveling

When the level is set up correctly and leveled the line of collimation will be horizontal telescope is rotated about its vertical axis it will revolve in a horizontal plane known as the plane of collimation and therefore, all staffs readings taken with the will be the vertical measurements made downwards from this plane.

To find by how much amount the line of sight is above the bench mark and To ascertain by how much amount the next point is below or above the

line sight. Height of instrument = Elevation of B.M + Back sight

Elevation of pt B = Height of instrument – Foresight

1.1.8.2 reduction level**Height of instrument method**

In this method, the height of instrument is calculated for each setting of instrument, and then the elevation or reduced level of the turning point is calculated with respect to the height of instrument

Rise and fall method:

In rise and fall method the difference of level between consecutive point is found comparing staff readings on the two points of same setting of the instrument

1.1.9 Plane table survey

Plane table survey is that type of survey in which the measurement of survey lines of the transverse and their plotting to a suitable scale are done simultaneously on the field. It consists of:

- ✓ Drawing Board mounted on a tripod
- ✓ Alidade

Drawing board:

The drawing board is made of well seasoned wood such as teak and its size varies from 400mm x 300mm to 750mm x 600 mm. the board is mounted on a tripod with ball and socket arrangement which allow the board to be leveled and rotated about the vertical axis.

Alidades:

The open sight alidade

The telescope alidade

The open slight alidade consists of a flat rectangular piece of wood of about, 25mm width, 12.5mm thickness and length varying from 200 to 500 mm. The leveled edge of the alidade is called the fiducial edge. Its edge is graduated and serves as a scale. Vertical sight vanes are mounted at both ends. One of the sight vanes is provided with a narrow slit and the other with a central vertical wire. The line of sight is in the same vertical plane as the fiducial edge. The telescope alidade consists of a telescope mounted on a horizontal axis the ends of which are supported on standards. A circular level or two spirit levels are attached to the base of the telescope to level the plane table.

Working operations

- ✓ Fixing
- ✓ Setting
- ✓ Levelling
- ✓ Orientation

Fixing

Fixing the table to the tripod stand

Setting

The table is set up at a convenient height say 1m above ground. The legs of the stand are spread apart and firmly fixed into the ground. The table is then centered. This means that the point plotted on the sheet corresponding to the station occupied should be exactly above the station on the ground. This is done by means of the plumbing fork.

Levelling

The table is then leveled either by ordinarily tilting the board or by ball and socket arrangement.

Orientation:

Orientation is the process of putting the plane table into some fixed direction so that a line representing a certain direction on the drawing sheet is parallel to that direction on the ground.

Two methods adopted:

- Orientation by magnetic needle
- Orientation by back sighting

1.1.9.1 Methods of plane table survey

- ✓ Radiation
- ✓ Intersection
- ✓ Traversing
- ✓ Resection

1.1.10 Stones

Stones, bricks, cement, lime and timber are the traditional materials used for civil engineering constructions for several centuries. In this chapter types, properties, tests and uses of these materials are explained.

Stone is a 'naturally available building material' which has been used from the early age of civilization. It is available in the form of rocks, which are cut to required size and shape and used as building blocks. It has been used to construct small residential buildings to large palaces and temples all over the world. Red Fort, Taj Mahal, Vidhan Sabha at Bangalore and several palaces of medieval age all over India are the famous stone buildings.

1.1.10.1 Type of Stones

Stones used for civil engineering works may be classified in the following three ways:

- ✓ Geological
- ✓ Physical
- ✓ Chemical

Geological classification

Based on their origin of formation stones are classified into three main groups—Igneous, sedimentary and metamorphic rocks.

(i) Igneous Rocks: These rocks are formed by cooling and solidifying of the rock masses from their molten magmatic condition of the material of the earth. Generally igneous rocks are strong and durable.

Granite, trap and basalt are the rocks belonging to this category, Granites are formed by slow cooling of the lava under thick cover on the top. Hence they have crystalline surface. The cooling of lava at the top surface of earth results into non-crystalline and glassy texture. Trap and basalt belong to this category

(ii) Sedimentary Rocks: Due to weathering action of water, wind and frost existing rocks disintegrates. The disintegrated material is carried by wind and water; the water being most powerful medium. Flowing water deposits its suspended materials at some points of obstacles to its flow. These deposited layers of materials get consolidated under pressure and by heat.

Chemical agents also contribute to the cementing of the deposits. The rocks thus formed are more uniform, fine grained and compact in their nature. They represent a bedded or stratified structure in general. Sand stones, lime stones, mud stones etc. belong to this class of rock.

(iii) Metamorphic Rocks: Previously formed igneous and sedimentary rocks under go changes due to metamorphic action of pressure and internal heat. For example due to metamorphic action granite becomes greisses, trap and basalt change to schist and laterite, lime stone changes to marble, sand stone becomes quartzite and mud stone becomes slate.

Physical Classification

Based on the structure, the rocks may be classified as:

- Stratified rocks
- Unstratified rocks

(i) Stratified Rocks: These rocks are having layered structure. They possess planes of stratification or cleavage. They can be easily split along these planes. Sand stones, lime stones, slate etc. are the examples of this class of stones.

(ii) Unstratified Rocks: These rocks are not stratified. They possess crystalline and compact grains. They cannot be split in to thin slab. Granite, trap, marble etc. are the examples of this type of rocks.

(iii) Foliated Rocks: These rocks have a tendency to split along a definite direction only. The direction need not be parallel to each other as in case of stratified rocks. This type of structure is very common in case of metamorphic rocks.

Chemical Classification

On the basis of their chemical composition engineers prefer to classify rocks as:

- Silicious rocks
- Argillaceous rocks and
- Calcareous rocks

(i) **Silicious rocks:** The main content of these rocks is silica. They are hard and durable. Examples of such rocks are granite, trap, sand stones etc.

(ii) **Argillaceous rocks:** The main constituent of these rocks is argil *i.e.*, clay. These stones are hard and durable but they are brittle. They cannot withstand shock. Slates and laterites are examples of this type of rocks.

1.1.2 Properties of Stones

The following properties of the stones should be looked into before selecting them for engineering works:

(i) **Structure:** The structure of the stone may be stratified (layered) or unstratified. Structured stones should be easily dressed and suitable for super structure. Unstratified stones are hard and difficult to dress. They are preferred for the foundation works.

(ii) **Texture:** Fine grained stones with homogeneous distribution look attractive and hence they are used for carving. Such stones are usually strong and durable.

(iii) **Density:** Denser stones are stronger. Light weight stones are weak. Hence stones with specific gravity less than 2.4 are considered unsuitable for buildings.

(iv) **Appearance:** A stone with uniform and attractive colour is durable, if grains are compact. Marble and granite get very good appearance, when polished. Hence they are used for face works in buildings.

(v) **Strength:** Strength is an important property to be looked into before selecting stone as building block. Indian standard code recommends, a minimum crushing strength of 3.5 N/mm^2 for any building block. Table 1.1.10.1 shows the crushing strength of various stones. Due to non-uniformity of the material, usually a factor of safety of 10 is used to find the permissible stress in a stone.

Hence even laterite can be used safely for a single storey building, because in such structures expected load can hardly give a stress of 0.15 N/mm^2 . However in stone masonry buildings care should be taken to check the stresses when the beams (Concentrated Loads) are placed on laterite wall.

Table 1.1.10.1. Crushing strength of common building stones

<i>Name of Stone</i>	<i>Crushing Strength in</i>
Trap	300 to 350
Basalt	153 to 189
Granite	104 to 140
Slate	70 to 210
Marble	72
Sand stone	65
Lime	65

(vi) **Hardness:** It is an important property to be considered when stone is used for flooring and pavement. Coefficient of hardness is to be found by conducting test on standard specimen in Dory's testing machine. For road works coefficient of hardness should be at least 17. For building works stones with coefficient of hardness less than 14 should not be used.

(vii) **Percentage wear:** It is measured by attrition test. It is an important property to be considered in selecting aggregate for road works and railway ballast. A good stone should not show wear of more than 2%.

(viii) **Porosity and Absorption:** All stones have pores and hence absorb water. The reaction of water with material of stone cause disintegration.

Absorption test is specified as percentage of water absorbed by the stone when it is immersed under water for 24 hours. For a good stone it should be as small as possible and in no case more than 5.

(ix) **Weathering:** Rain and wind cause loss of good appearance of stones. Hence stones with good weather resistance should be used for face works.

(x) **Toughness:** The resistance to impact is called toughness. It is determined by impact test. Stones with toughness index more than 19 are preferred for road works. Toughness index 13 to 19 are considered as medium tough and stones with toughness index less than 13 are poor stones.

(xi) **Resistance to Fire:** Sand stones resist fire better. Argillaceous materials, though poor in strength, are good in resisting fire.

(xii) **Ease in Dressing:** Cost of dressing contributes to cost of stone masonry to a great extent. Dressing is easy in stones with lesser strength. Hence an engineer should look into sufficient strength rather than high strength while selecting stones for building works.

(xiii) **Seasoning:** The stones obtained from quarry contain moisture in the pores. The strength of the stone improves if this moisture is removed before using the stone. The process of removing moisture from pores is called seasoning.

1.1.10.2 Requirements of Good Building Stones

The following are the requirements of good building stones:

(i) **Strength:** The stone should be able to resist the load coming on it.

Ordinarily this is not of primary concern since all stones are having good strength. However in case of large structure, it may be necessary to check the strength.

(ii) **Durability:** Stones selected should be capable of resisting adverse effects of natural forces like wind, rain and heat.

(iii) **Hardness:** The stone used in floors and pavements should be able to resist abrasive forces caused by movement of men and materials over them.

(iv) **Toughness:** Building stones should be tough enough to sustain stresses developed due to vibrations. The vibrations may be due to the machinery mounted over them or due to the loads moving over them. The stone aggregates used in the road constructions should be tough.

(v) **Specific Gravity:** Heavier variety of stones should be used for the construction of dams, retaining walls, docks and harbours. The specific gravity of good building stone is between 2.4 and 2.8.

(vi) **Porosity and Absorption:** Building stone should not be porous. If it is porous rain water enters into the pores and reacts with stone and crumbles it. In higher altitudes, the freezing of water in pores takes place and it results into the disintegration of the stone

(vii) **Dressing:** Giving required shape to the stone is called dressing. It should be easy to dress so that the cost of dressing is reduced. However the care should be taken so that, this is not be at the cost of the required strength and the durability.

(viii) **Appearance:** In case of the stones to be used for face works, where appearance is a primary requirement, its colour and ability to receive polish is an important factor.

(ix) **Seasoning:** Good stones should be free from the quarry sap.

Laterite stones should not be used for 6 to 12 months after quarrying. They are allowed to get rid of quarry sap by the action of nature. This process of removing quarry sap is called seasoning.

(x) **Cost:** Cost is an important consideration in selecting a building material. Proximity of the quarry to building site brings down the cost of transportation and hence the cost of stones comes down.

However it may be noted that not a single stone can satisfy all the requirements of a good building stones, since one requirement may contradict another. For example, strength and durability requirement contradicts ease of dressing requirement. Hence it is necessary that site engineer looks into the properties required for the intended work and selects the stone

1.1.10.3 Tests on Stones

To certain the required properties of stones, the following tests can conducted:

- (i) Crushing strength test
- (ii) Water absorption test
- (iii) abrasion test
- (iv) Impact test
- (v) Acid test.

1.1.10.4 Uses of Stones

Stones are used in the following civil engineering constructions:

- (i) Stone masonry is used for the construction of foundations, walls, columns and arches.
- (ii) Stones are used for flooring.
- (iii) Stone slabs are used as damp proof courses, lintels and even as roofing materials.
- (iv) Stones with good appearance are used for the face works of buildings. Polished marbles and granite are commonly used for face works.
- (v) Stones are used for paving of roads, footpaths and open spaces round the buildings.
- (vi) Stones are also used in the constructions of piers and abutments of bridges, dams and retaining walls.
- (vii) Crushed stones with gravel are used to provide base course for roads. When mixed with tar they form finishing coat.
- (viii) Crushed stones are used in the following works

- also: (a) As a basic inert material in concrete
(b) For making artificial stones and building blocks
(c) As railway ballast.

1.1.11 Bricks

Brick is obtained by moulding good clay into a block, which is dried and then burnt. This is the oldest building block to replace stone. Manufacture of brick started with hand moulding, sun drying and burning in clamps. A considerable amount of technological development has taken place with better Knowledge about to properties of raw materials, better machineries and improved techniques of moulding drying and burning.

The size of the bricks are of 90 mm × 90 mm × 90 mm and 190 mm × 90 mm × 40 mm. With mortar joints, the size of these bricks are taken as 200 mm × 100 mm × 100 mm and 200 mm × 100 mm

(i) Building Bricks: These bricks are used for the construction of walls.

(ii) Paving Bricks: These are vitrified bricks and are used as pavers.

(iii) Fire Bricks: These bricks are specially made to withstand furnace temperature. Silica bricks belong to this category.

(iv) Special Bricks: These bricks are different from the commonly used building bricks with respect to their shape and the purpose for which they are made. Some of such bricks are listed below:

- (a) Specially shaped bricks
- (b) Facing bricks
- (c) Perforated building bricks
- (d) Burnt clay hollow bricks
- (e) Sewer bricks
- (f) Acid resistant bricks

(a) Specially Shaped Bricks: Bricks of special shapes are manufactured to meet the requirements of different situations. Some of them are shown in Fig. 1.1.11.

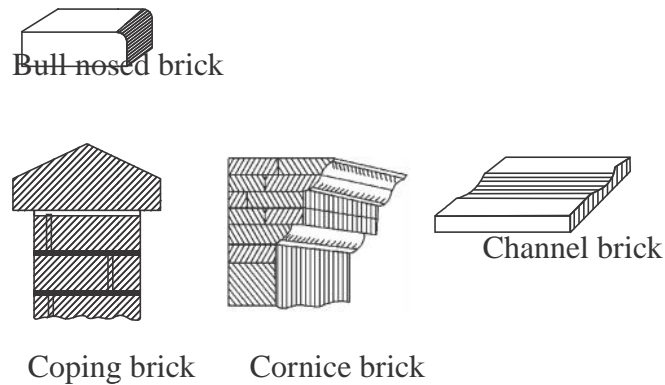
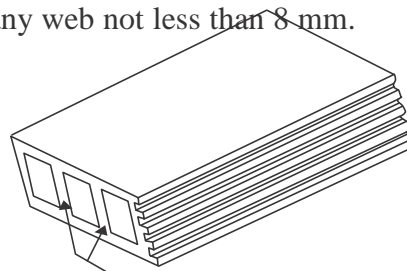

Fig. 1.1.11 Special shaped bricks

(b) Facing Bricks: These bricks are used in the outer face of masonry. Once these bricks are provided, plastering is not required. The standard size of these bricks is $190 \times 90 \times 90$ mm or $190 \times 90 \times 40$ mm.

(c) Perforated Building Bricks: These bricks are manufactured with area of perforation of 30 to 45 per cent. The area of each perforation should not exceed 500 mm^2 . The perforation should be uniformly distributed over the surface. They are manufactured in the size $190 \times 190 \times 90$ mm and $290 \times 90 \times 90$ mm

(d) Burn't Clay Hollow Bricks: Figure 1.1.11.1 shows a burnt clay hollow brick. They are light in weight. They are used for the construction of partition walls. They provide good thermal insulation to buildings. They are manufactured in the sizes $190 \times 190 \times 90$ mm, $290 \times 90 \times 90$ mm and $290 \times 140 \times 90$ mm. The thickness of any shell should not be less than 11 mm and that of any web not less than 8 mm.



WEBS 8 mm
minimum thick
Fig. 1.1.11.1 Hollow
brick

(e) Sewer Bricks: These bricks are used for the construction of sewage lines. They are manufactured from surface clay, fire clay shale or with the combination of these. They are manufactured in the sizes $190 \times 90 \times 90$ mm and $190 \times 90 \times 40$ mm. The average strength of these bricks should be a minimum of 17.5 N/mm^2 . The water absorption should not be more than 10 per cent.

(f) **Acid Resistant Bricks:** These bricks are used for floorings likely to be subjected to acid attacks, lining of chambers in chemical plants, lining of sewers carrying industrial wastes etc. These bricks are made of clay or shale of suitable composition with low lime and iron content, flint or sand and vitrified at high temperature in a ceramic kiln.

1.1.11.1 Properties of Bricks

The following are the required properties of good Bricks:

(i) **Colour:** Colour should be uniform and bright.

(ii) **Shape:** Bricks should have plane faces. They should have sharp and true right angled corners.

(iii) **Size:** Bricks should be of standard sizes as prescribed by codes. (iv) **Texture:** They should possess fine, dense and uniform texture. They should not possess fissures, cavities, loose grit and unburnt lime.

(v) **Soundness:** When struck with hammer or with another brick, it should produce metallic sound.

(vi) **Hardness:** Finger scratching should not produce any impression on the brick.

(vii) **Strength:** Crushing strength of brick should not be less than 3.5 N/mm^2 . A field test for strength is that when dropped from a height of 0.9 m to 1.0 m on a hard ground, the brick should not break into pieces.

(viii) **Water Absorption:** After immersing the brick in water for 24 hours, water absorption should not be more than 20 per cent by weight. For class-I works this limit is 15 per cent.

(ix) **Efflorescence:** Bricks should not show white patches when soaked in water for 24 hours and then allowed to dry in shade. White patches are due to the presence of sulphate of calcium, magnesium and potassium. They keep the masonry permanently in damp and wet conditions.

(x) **Thermal Conductivity:** Bricks should have low thermal conductivity, so that buildings built with them are cool in summer and warm in winter.

(xi) **Sound Insulation:** Heavier bricks are poor insulators of sound while light weight and hollow bricks provide good sound insulation.

(xii) **Fire Resistance:** Fire resistance of bricks is usually good. In fact bricks are used to encase steel columns to protect them from fire

1.1.11.2 Tests on Bricks

The following *laboratory tests* may be conducted on the bricks to find their suitability:

- (i) Crushing strength
- (ii) Absorption
- (iii) Shape and size and
- (iv) Efflorescence.

(i) **Crushing Strength:** The brick specimen are immersed in water for 24 hours. The frog of the brick is filled flush with 1:3 cement mortar and the specimen is stored in damp jute bag for 24 hours and then immersed in clean water for 24 hours. The specimen is placed in

compression testing machine with 6 mm plywood on top and bottom of it to get uniform load on the specimen. Then load is applied axially at a uniform rate of 14 N/mm^2 . The crushing load is noted. Then the crushing strength is the ratio of crushing load to the area of brick loaded. Average of five specimen is taken as the crushing strength.

(ii) Absorption Test: Brick specimen are weighed dry. Then they are immersed in water for a period of 24 hours. The specimen are taken out and wiped with cloth.

The weight of each specimen in wet condition is determined. The difference in weight indicate the water absorbed. Then the percentage absorption is the ratio of water absorbed to dry weight multiplied by 100. The average of five specimen is taken. This value should not exceed 20 per cent.

iii) Shape and Size: Bricks should be of standard size and edges should be truly rectangular with sharp edges. To check it, 20 bricks are selected at random and they are stacked along the length, along the width and then along the height. For the standard bricks of size $190 \text{ mm} \times 90 \text{ mm} \times 90 \text{ mm}$. IS code permits the following limits:

Lengthwise:	3680 to 3920mm
Widthwise:	1740 to 1860mm
Heightwise:	1740 to 1860mm

The following *field tests* help in ascertaining the good quality bricks:

(i) uniformity in size

(ii) uniformity in colour

(iii) structure

(iv) hardness test

(v) sound test

(vi) strength test.

(i) Uniformity in Size: A good brick should have rectangular plane surface and uniform in size. This check is made in the field by observation.

(ii) Uniformity in Colour: A good brick will be having uniform colour throughout. This observation may be made before purchasing the brick.

(iii) Structure: A few bricks may be broken in the field and their cross-section observed. The section should be homogeneous, compact and free from defects such as holes and lumps.

(iv) Sound Test: If two bricks are struck with each other they should produce clear ringing sound. The sound should not be dull.

(v) Hardness Test: For this a simple field test is scratch the brick with nail. If no impression is marked on the surface, the brick is sufficiently hard

(vi) Efflorescence: The presence of alkalies in brick is not desirable because they form patches of gray powder by absorbing moisture. Hence to determine the presence of alkalies this test is performed as explained below:

Place the brick specimen in a glass dish containing water to a depth of 25 mm in a well ventilated room. After all the water is absorbed or evaporated again add water for a depth of 25 mm. After second evaporation observe the bricks for white/grey patches. The observation is reported as 'nil', 'slight 'moderate', 'heavy' or serious to mean

- (a) Nil: No patches
- (b) Slight: 10% of area covered with deposits
- (c) Moderate: 10 to 50% area covered with deposit but unaccompanied by flaking of the surface. (d) Heavy: More than 50 per cent area covered with deposits but unaccompanied by flaking the surface.
- (e) Serious: Heavy deposits of salt accompanied by flaking of the surface.

1.1.11.3 Classification of Bricks Based on their Quality

The bricks used in construction are classified as:

- (i) First class bricks
 - (ii) Second class bricks
 - (iii) Third class bricks and
 - (iv) Fourth class bricks
- (i) First Class Bricks:** These bricks are of standard shape and size. They are burnt in kilns. They fulfill all desirable properties of bricks.
- (ii) Second Class Bricks:** These bricks are ground moulded and burnt in kilns. The edges may not be sharp and uniform. The surface may be some what rough. Such bricks are commonly used for the construction of walls which are going to be plastered.
- (iii) Third Class Bricks:** These bricks are ground moulded and burnt in clamps. Their edges are somewhat distorted. They produce dull sound when struck together. They are used for temporary and unimportant structures.
- (iv) Fourth Class Bricks:** These are the over burnt bricks. They are dark in colour. The shape is irregular. They are used as aggregates for concrete in foundations, floors and roads.

1.1.11.4 Uses of Bricks

Bricks are used in the following civil works:

- (i) As building blocks.
- (ii) For lining of ovens, furnaces and chimneys.
- (iii) For protecting steel columns from fire.
- (iv) As aggregates in providing water proofing to R.C.C. roofs.
- (v) For pavers for footpaths and cycle tracks.
- (vi) For lining sewer lines.

1.1.12 CEMENT

Cement is a commonly used binding material in the construction. The cement is obtained by burning a mixture of calcarious (calcium) and argillaceous (clay) material at a very high temperature and then grinding the clinker so produced to a fine powder. It was first produced by a mason Joseph Aspdin in England in 1924. He patented it as portland cement

1.1.12.1 Types of Cement

In addition to ordinary portland cement there are many varieties of cement. Important varieties are briefly explained below:

(i) White Cement: The cement when made free from colouring oxides of iron, manganese and chlorine results into white cement. In the manufacture of this cement, the oil fuel is used instead of coal for burning. White cement is used for the floor finishes, plastering, ornamental works etc. In swimming pools white cement is used to replace glazed tiles. It is used for fixing marbles and glazed tiles.

(ii) Coloured Cement: The cements of desired colours are produced by intimately mixing pigments with ordinary cement. The chlorine oxide gives green colour. Cobalt produce blue colour. Iron oxide with different proportion produce brown, red or yellow colour. Addition of manganese dioxide gives black or brown coloured cement. These cements are used for giving finishing touches to floors, walls, window sills, roofs etc.

(iii) Quick Setting Cement: Quick setting cement is produced by reducing the percentage of gypsum and adding a small amount of aluminium sulphate during the manufacture of cement. Finer grinding also adds to quick setting property. This cement starts setting within 5 minutes after adding water and becomes hard mass within 30 minutes. This cement is used to lay concrete under static or slowly running water.

(iv) Rapid Hardening Cement: This cement can be produced by increasing lime content and burning at high temperature while manufacturing cement. Grinding to very fine is also necessary. Though the initial and final setting time of this cement is the same as that of portland cement, it gains strength in early days. This property helps in earlier removal of form works and speed in construction activity.

(v) Low Heat Cement: In mass concrete works like construction of dams, heat produced due to hydration of cement will not get dispersed easily. This may give rise to cracks. Hence in such constructions it is preferable to use low heat cement. This cement contains low percentage (5%) of tricalcium aluminate (C_3A) and higher percentage (46%) of dicalcium silicate (C_2S).

(vi) Pozzulana Cement: Pozzulana is a volcanic power found in Italy. It can be processed from shales and certain types of clay also. In this cement pozzulana material is 10 to 30 per cent. It can resist action of sulphate. It releases less heat during setting. It imparts higher degree of water tightness. Its tensile strength is high but compressive strength is low. It is used for mass concrete works. It is also used in sewage line works.

(vii) Expanding Cement: This cement expands as it sets. This property is achieved by adding expanding medium like sulpho aluminate and a stabilizing agent to ordinary cement. This is used for filling the cracks in concrete structures.

(viii) High Alumina Cement: It is manufactured by calcining a mixture of lime and bauxite. It is more resistant to sulphate and acid attack. It develops almost full strength within 24 hours of adding water. It is used for under water works.

(ix) Blast Furnace Cement: In the manufacture of pig iron, slag comes out as a waste product. By grinding clinkers of cement with about 60 to 65 per cent of slag, this cement is produced. The properties of this cement are more or less same as ordinary cement, but it is cheap, since it utilise waste product.

This cement is durable but it gains the strength slowly and hence needs longer period of curing.

(x) Acid Resistant Cement: This cement is produced by adding acid resistant aggregated such as quartz, quartzite, sodium silicate or soluble glass. This cement has good resistance to action of acid and water. It is commonly used in the construction of chemical factories.

(xi) Sulphate Resistant Cement: By keeping the percentage of tricalcium aluminate C_3A below five per cent in ordinary cement this cement is produced. It is used in the construction of structures which are likely to be damaged by alkaline conditions. Examples of such structures are canals, culverts etc.

(xii) Fly Ash Blended Cement: Fly ash is a byproduct in thermal stations. The particles of fly ash are very minute and they fly in the air, creating air pollution problems. Thermal power stations have to spend lot of money to arrest fly ash and dispose safely.

It is found that one of the best way to dispose fly ash is to mix it with cement in controlled condition and derive some of the beneficiary effects on cement. Now-a-days cement factories produce the fly ash in their own thermal stations or borrow it from other thermal stations and further process it to make it suitable to blend with cement. 20 to 30% fly ash is used for blending.

Fly ash blended cements have superior quality of resistance to weathering action. The ultimate strength gained is the same as that with ordinary portland cement. However strength gained in the initial stage is slow. Birla plus, Birla star, A.C.C. Suraksha are some of the brand make of blended cement.

1.1.12.2 Properties of Ordinary Portland Cement

(i) Chemical properties: Portland cement consists of the following chemical compounds:

(a) Tricalcium silicate	$3 \text{ CaO} \cdot \text{SiO}_2$ (C_3S)	40%
(b) Dicalcium silicate	$2\text{CaO} \cdot \text{SiO}_2$ (C_2S)	30
(c) Tricalcium aluminate	$3\text{CaO} \cdot \text{Al}_2\text{O}_3$ (C_3A)	11
(d) Tetracalcium aluminate	$4\text{CaO} \cdot \text{Al}_2\text{O}_3 \cdot \text{Fe}_2\text{O}_3$	11

There may be small quantities of impurities present such as calcium oxide (CaO) and magnesiumoxide (MgO).

When water is added to cement, C_3A is the first to react and cause initial set. It generates great amount of heat. C_3S hydrates early and develops strength in the first 28 days. It also generates heat. C_2S is the next to hydrate. It hydrates slowly and is responsible for increase in ultimate strength. C_4AF is comparatively inactive compound.

(ii) Physical properties: The following physical properties should be checked before selecting a portland cement for the civil engineering works. IS 269–1967 specifies the method of testing and prescribes the limits:

- (a) Fineness
(b) Setting time
(c) Soundness
(d) Crushing strength.

(a) **Fineness:** It is measured in terms of percentage of weight retained after sieving the cement through 90 micron sieve or by surface area of cement in square centimeters per gramme of cement. According to IS code specification weight retained on the sieve should not be more than 10 per cent. In terms of specific surface should not be less than $2250 \text{ cm}^2/\text{gm}$.

(b) **Setting time:** A period of 30 minutes as minimum setting time for initial setting and a maximum period of 600 minutes as maximum setting time is specified by IS code, provided the tests are conducted as per the procedure prescribed by IS 269-1967.

(c) **Soundness:** Once the concrete has hardened it is necessary to ensure that no volumetric changes takes place.

The cement is said to be unsound, if it exhibits volumetric instability after hardening. IS code recommends test with Le Chatelier mould for testing this property. At the end of the test, the indicator of Le Chatelier mould should not expand by more than 10 mm.

(d) **Crushing strength:** For this mortar cubes are made with standard sand and tested in compression testing machine as per the specification of IS code. The minimum strength specified is 16 N/mm^2 after 3 days and 22 N/mm^2 after 7 days of curing.

1.1.12.3 Uses of Cement

Cement is used widely for the construction of various structures. Some of them are listed below:

- (i) Cement slurry is used for filling cracks in concrete structures.
- (ii) Cement mortar is used for masonry work, plastering and pointing.
- (iii) Cement concrete is used for the construction of various structures like buildings, bridges, water tanks, tunnels, docks, harbours etc.
- (iv) Cement is used to manufacture lamp posts, telephone posts, railway sleepers, piles etc.
- (v) For manufacturing cement pipes, garden seats, dust bins, flower pots etc. cement is commonly used.
- (vi) It is useful for the construction of roads, footpaths, courts for various sports etc.

1.1.13 Sand

Sand is a natural product which is obtained as river sand, nalla sand and pit sand. However sea sand should not be used for the following reasons:

1. It contains salt and hence structure will remain damp. The mortar is affected by efflorescence and blisters appear.
2. It contains shells and other organic matter, which decompose after some time, reducing the life of the mortar.

Sand may be obtained artificially by crushing hard stones. Usually artificial sand is obtained as a by-product while crushing stones to get jelly (coarse aggregate).

Sand is used in mortar and concrete for the following purpose:

1. It sub-divides the paste of binding material into thin films and allows it to adhere and spread.
2. It fills up the gap between the building blocks and spreads the binding material.
3. It adds to the density of the mortar.
4. It prevents the shrinkage of the cementing material.
5. It allows carbon dioxide from the atmosphere to reach some depth and thereby improve setting power.
6. The cost of cementing material per unit volume is reduced as this low cost material increases the volume of mortar.
7. Silica of sand contributes to formation of silicates resulting into the hardened mass.

The properties of good sand are:

1. It should be chemically inert.
2. It should be free from organic or vegetable matter.
3. It should be free from salt.
4. It should contain sharp, angular and coarse grains.
5. It should be well graded.
6. It should be hard.

1.1.13PLAIN CONCRETE

Plain concrete, commonly known as concrete, is an intimate mixture of binding material, fine aggregate, coarse aggregate and water. This can be easily moulded to desired shape and size before it loses plasticity and hardens. Plain concrete is strong in compression but very weak in tension. The tensile property is introduced in concrete by inducting different materials and this attempt has given rise to RCC, RBC, PSC, FRC, cellular concrete and Ferro cement. In this chapter proportioning, mixing, curing, properties, tests and uses of plain concrete is dealt in detail. The other improved versions of concrete are explained and their special properties and uses are pointed out.

Major ingredients of concrete are:

1. Binding material (like cement, lime, polymer)
2. Fine aggregate (sand)
3. Coarse aggregates (crushed stone, jelly)
4. Water.

A small quantity of admixtures like air entraining agents, water proofing agents, workability agents etc. may also be added to impart special properties to the plain concrete mixture.

Depending upon the proportion of ingredient, strength of concrete varies. It is possible to determine the proportion of the ingredients for a particular strength by mix design procedure.

.In proportioning of concrete it is kept in mind that voids in coarse aggregates are filled with sand and the voids in sand are filled with cement paste.

FunctionsofVarious Ingredients

Cement is the binding material. After addition of water it hydrates and binds aggregates and the surrounding surfaces like stone and bricks. Generally richer mix (with more cement) gives more strength. Setting time starts after 30 minutes and ends after 6 hours. Hence concrete should be laid in its mould before 30 minutes of mixing of water and should not be subjected to any external forces till final setting takes place.

Coarse aggregate consists of crushed stones. It should be well graded and the stones should be of igneous origin. They should be clean, sharp, angular and hard. They give mass to the concrete and prevent shrinkage of cement. Fine aggregate consists of river sand. It prevents shrinkage of cement. When surrounded by cement it gains mobility enters the voids in coarse aggregates and binding of ingredients takes place. It adds density to concrete, since it fills the voids. Denser the concrete higher is its strength.

Water used for making concrete should be clean. It activates the hydration of cement and forms plastic mass. As it sets completely concrete becomes hard mass. Water gives workability to concrete which means water makes it possible to mix the concrete with ease and place it in final position. More the water better is the workability.

However excess water reduces the strength of concrete. Figure 1.1.13.1 shows the variation of strength of concrete with water cement ratio. To achieve required workability and at the same time good strength a water cement ratio of 0.4 to 0.45 is used, in case of machine mixing and water cement ratio of 0.5 to 0.6 is used for hand mixing.

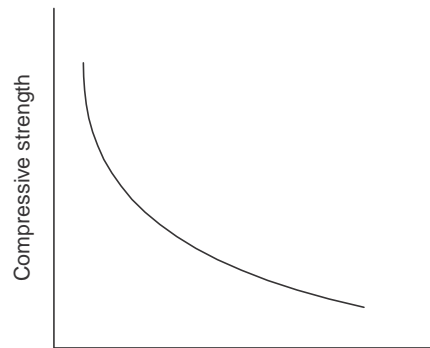

Water/cement ratio

1.1.13.1 Properties of Green concrete

1. Workability: This is defined as the ease with which concrete can be compacted fully without segregating and bleeding. It can also be defined as the amount of internal work required to fully compact the concrete to optimum density. The workability depends upon the quantity of water, grading, shape and the percentage of the aggregates present in the concrete.

Workability is measured by

(a) The slump observed when the frustum of the standard cone filled with concrete is lifted and removed.

(b) The compaction factor determined after allowing the concrete to fall through the compaction testing machine.

(c) The time taken in seconds for the shape of the concrete to change from cone to cylinder when tested in Vee-Bee consistometer.

The suggested values of workability for different works are as shown in Table 1.1.13.1.

Table 1.1.13.1. Suggested values of workability

<i>Application</i>	<i>Slump</i>	<i>Compaction</i>	<i>Time in Vee-</i>
1. Concreting of shallow sections with vibrations	— —	0.75 – 0.80	10 – 20
2. Concreting of light reinforced sections with vibrators	25 – 75 mm	0.80 – 0.85	5 – 10
3. Concreting of lightly reinforced sections		0.85 –	2 –

2. Segregation: Separation of coarse particles from the green concrete is called segregation. This may happen due to lack of sufficient quantity of finer particles in concrete or due to throwing of the

concrete from greater heights at the time of placing the concrete. Because of the segregation, the cohesiveness of the concrete is lost and honey combing results. Ultimately it results in the loss of strength of hardened concrete. Hence utmost care is to be taken to avoid segregation.

3. Bleeding: This refers to the appearance of the water along with cement particles on the surface of the freshly laid concrete. This happens when there is excessive quantity of water in the mix or due to excessive compaction. Bleeding causes the formation of pores and renders the concrete weak. Bleeding can be avoided by suitably controlling the quantity of water in the concrete and by using finer grading of aggregate

4. Harshness: Harshness is the resistance offered by concrete to its surface finish. Harshness is due to presence of lesser quantity of fine aggregates, lesser cement mortar and due to use of poorly graded aggregates. It may result due to insufficient quantity of water also. With harsh concrete it is difficult to get a smooth surface finish and concrete becomes porous.

1.1.13.2 Tests on Concrete

The following are some of the important tests conducted on concrete:

1. Slump test.

2. Compaction factor test.
3. Crushing strength test.

1. Slump Test: This test is conducted to determine the workability of concrete. It needs a slump cone for test (Fig. 3.3). Slump cone is a vessel in the shape of a frustum of a cone with diameter at bottom 200 mm and 50 mm at top and 300 mm high. This cone is kept over a impervious platform and is filled with concrete in four layers.

Each layer is tamped with a 16 mm pointed rod for 25 times. After filling completely the cone is gently pulled up. The decrease in the height of the concrete is called slump. Higher the slump, more workable is the concrete. The desired values of slumps for various works have been shown in Table 1.1.13.1

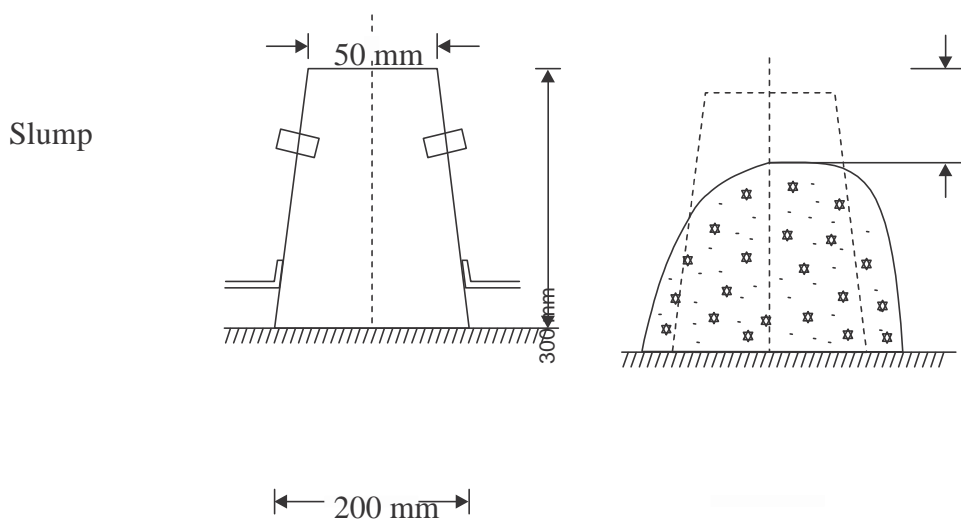

Fig.1.1.13.1 Slump test

2. Compaction Factor Test: This is another test to identify the workability of concrete. This test is conducted in the laboratory. The test equipment consists of two hoppers and a cylinder fixed to a stand, the dimensions and the distances between the three vessels being standardized. Vessel A and B are having hinged bottoms whereas cylinder C is having fixed bottom. [Ref. Fig. 1.1.13.2]

Top vessel A is filled with the concrete to be tested. As soon as it is filled, the hinged door is opened. Concrete is collected in vessel B. Then the hinged door of B is opened to collect concrete in cylinder C. The concrete in cylinder C is weighted. Let it be W_1 .

Now cylinder is again filled with the sample of concrete in 50 mm layers, which is compacted by ramming and vibrating. Then the weight of compacted concrete is determined. Let this weight be W_2 .

The ratio W_1/W_2 is termed as compaction factor. The specified values of compaction factor for different works are already listed in Table 3.2.

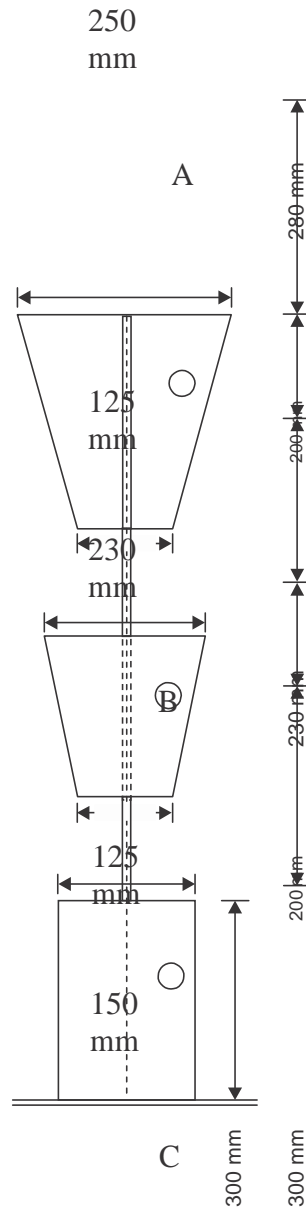

Fig. 1.1.13.2 Compaction factor test

3. **Crushing Strength Test:** Metallic moulds of size 150 mm × 150 mm × 150 mm are used for casting concrete cubes. Before filling mould, it is properly oiled on its inner surfaces, so that cubes can be easily separated. Fresh cube is filled with concrete to be tested in 3 layers and kept in the room. After 24 hours, cube is removed from the mould and kept under water for curing. After 28 days of curing cubes are tested in the compression testing machine. In this test cubes are placed over the smooth surface which is in contact with side plates of mould.

The crushing load is noted and crushing strength is found as load divided by surface area ($150 \times 150 \text{ mm}^2$). Code specify the desirable strength of concrete for 3 days and 7 days for quick assessment of strength of concrete.

Desirable Properties Concrete

Appropriate quality and quantity of cement, fine aggregate, coarse aggregate and water should be used so that the green concrete has the following properties:

- (a) Desired workability
- (b) No segregation in transporting and placing
- (c) No bleeding and
- (d) No harshness

1.1.14 FERROUS METALS

A ferrous material is the one in which iron is a main constituent. Iron ore is first converted into pig iron and then pig iron is subjected to various metallurgical processes to mix different percentage of carbon and to get the following three useful ferrous materials:

1. Cast iron—carbon content 1.7% to 4.5%
2. Wrought iron—carbon content 0.05% to 0.15%
3. Steel—carbon content 0.25% to 0.25%.

All ferrous materials contain about 0.5 to 3% silica, less than 2% manganese, 0.15% sulphur and 0.6% phosphorous.

1. Cast Iron: Important *properties* of cast iron are:

- (a) Compression strength is 700 N/mm^2 and tensile strength is 150 N/mm^2 .
- (b) It is brittle and does not absorb shocks
- (c) Its specific gravity is 7.5.
- (d) Its structure is coarse, crystalline and fibrous.
- (e) It cannot be magnetised.
- (f) It does not rust-easily.
- (g) It has low melting point of about 1200°C .

Uses of Cast Iron:

1. It is used for making rain water and sanitary pipes, sanitary fittings and manhole covers.
2. It is used for making railings and spiral stair cases.
3. Fire gratings; cover for pumps and motors and brackets are made with cast irons.

Properties of Wrought Iron:

1. Its ultimate compressive strength is 200 N/mm^2 and ultimate tensile strength is 375 N/mm^2 .
2. It is ductile and brittle.
3. Its unit weight is 77 kN/m^3 .
4. It melts at about 1500°C . It becomes so soft at 900°C that two pieces can be joined by hammering.
5. It can absorb shocks very well.
6. It forms temporary magnets but it cannot be magnetised permanently.
7. It rusts more easily.

Uses of Wrought Iron:

1. It is used for making nails nuts and bolts, wires and chains
2. It is used for making roofing sheets, grills, fences, window guards etc.
3. Steel: It is extensively used building material. The following three varieties of steel are extensively used:
 - (a) Mild steel
 - (b) High carbon steel and
 - (c) High tensile steel.

(a) Mild Steel: It contains a maximum of 0.25% carbon, 0.055% of sulphur and 0.55% of phosphorus.

Properties of Mild Steel:

- (i) It is malleable and ductile
- (ii) It is more elastic
- (iii) It can be magnetized permanently.
- (iv) Its specific gravity is 7.8.
- (v) Its Young's modulus is $2.1 \times 10^5 \text{ N/mm}^2$.
- (vi) It can be welded easily.
- (vii) It is equally strong in tension and in compression.

Uses of Mild Steel:

- (i) Round bars are extensively used as reinforcement in R.C.C. works.
- (ii) Rolled sections like I, T, L, C, plates etc. are used to build steel columns, beams, trusses etc.
- (iii) Tubular sections are used as poles and members of trusses.
- (iv) Plain and corrugated mild steel are used as roofing materials.
- (v) Mild steel sections are used in making parts of many types of machinery.

b) High Carbon Steel: The carbon contains in this steel is 0.7% to 1.5%.

Properties of Carbon Steel:

- (i) It is more tough and elastic compared to mild steel.
- (ii) Welding is difficult.
- (iii) It can be magnetized permanently.
- (iv) It is stronger in compression than in tension.
- (v) It withstands shocks and vibrations better.

Uses of High Carbon Steel:

- (i) It is used for making tools such as drills, files, chisels.
- (ii) Many machine parts are made with high carbon steel since it is capable of withstanding shocks and vibrations.

(c) High Tensile Steel: It contains 0.8% carbon and 0.6% manganese. The strength of this steel is quite high. High tensile steel wires are used in prestressed concrete works.

UNIT II

BUILDING COMPONENTS AND STRUCTURES

Foundations: Types, Bearing capacity – Requirement of good foundations.

Superstructure: Brick masonry – stone masonry – beams – columns – lintels – roofing – flooring – plastering – Mechanics – Internal and external forces – stress – strain – elasticity – Types of Bridges and Dams – Basics of Interior Design and Landscaping.

2.1 Introduction

Every family needs a building to reside. Apart from residential purposes buildings are required for educational, institutional, business, assembly and for industrial purposes. Buildings are required for the storage of materials also.

In this chapter basic requirements of buildings are presented and then planning of the building with respect to orientation, utility of space, energy efficiency and other requirements are explained.

2.1.1 Elements of a building

The following are the basic elements of a building:

1. Foundation
2. Plinth
3. Walls and columns
4. Sills, lintels and chejjas
5. Doors and windows
6. Floors
7. Roofs
8. Steps, stairs and lifts
9. Finishing work
10. Building services.

The functions of these elements and the main requirement of them is presented in this article.

1. Foundation: Foundation is the most important part of the building. Building activity starts with digging the ground for foundation and then building it. It is the lower most part of the building. It transfers the load of the building to the ground. Its main functions and requirements are:

- (a) Distribute the load from the structure to soil evenly and safely.
- (b) To anchor the building to the ground so that under lateral loads building will not move.
- (c) It gives level surface for the construction of super structure.

2. Plinth: The portion of the wall between the ground level and the ground floor level is called plinth. It is usually of stone masonry. If the foundation is on piles, a plinth beam is cast to support wall above floor level.

At the top of plinth a damp proof course is provided. It is usually 75 mm thick plain concrete course.

The function of the plinth is to keep the ground floor above ground level, free of dampness. Its height is not less than 450 mm. It is required that plinth level is at least 150 mm above the road level, so that connections to underground drainage system can be made.

3. Walls and Columns: The function of walls and columns is to transfer the load of the structure vertically downwards to transfer it to foundation. Apart from this wall performs the following functions also:

- (a) It encloses building area into different compartments and provides privacy.
- (b) It provides safety from burglary and insects.
- (c) It keeps the building warm in winter and cool in summer.

4. Sills, Lintels and Chejjas: A window frame should not be directly placed over masonry. It is placed over 50 mm to 75 mm thick plain concrete course provided over the masonry. This course is called as sill. Lintels are the R.C.C. or stone beams provided over the door and window openings to transfer the load transversely so as to see that door or window frame is not stressed unduly. The width of lintels is equal to the width of wall while thickness to be provided depends upon the opening size. Chejja is the projection given outside the wall to protect doors and windows from the rain. They are usually made with R.C.C. In low cost houses stone slabs are provided as chejjas. The projection of chejja varies from 600 mm to 800 mm. Sometimes drops are also provided to chejjas to improve aesthetic look and also to get additional protection from sun and rain.

5. Doors and Windows: The function of a door is to give access to different rooms in the building and to deny the access whenever necessary. Number of doors should be minimum possible. The size of the door should be of such dimension as will facilitate the movement of the largest object likely to use the door.

Windows are provided to get light and ventilation in the building. They are located at a height of 0.75 m to 0.9 m from the floor level. In hot and humid regions, the window area should be 15 to 20 per cent of the floor area. Another thumb rule used to determine the size and the number of windows is for every 30 m^3 of inside volume there should be 1 m^2 window opening.

6. Floors: Floors are the important component of a building. They give working/useful area for the occupants. The ground floor is prepared by filling brick bats, waste stones, gravel and well compacted with not less than 100 mm sand layer on its top. A lean concrete of 1 : 4 : 8, 100 mm thick is laid. On this a damp proof course may be provided. Then floor finishing is done as per the requirement of the owner. Cheapest floor finish for a moderate house is with 20 to 25 mm rich mortar course finished with red oxide. The costliest floor finish is mosaic or marble finishing.

7. Roof: Roof is the top most portion of the building which provide top cover to the building. It should be leak proof. Sloping roof like tiled and A.C. sheet give leak proof cover easily. But they do not give provision for the construction of additional floor. Tiled

roof give good thermal protection.

Flat roofs give provision for additional floors. Terrace adds to the comfort of occupants. Water tanks can be easily placed over the flat roofs.

8. Step, Stairs and Lifts: Steps give convenient access from ground level to ground floor level. They are required at doors in the outer wall. 250 to 300 mm wide and 150 mm rise is ideal size for steps. In no case the size of two consecutive steps be different. Number of steps required depends upon the difference in the levels of the ground and the floor. Stairs give access from floor to floor. They should consists of steps of uniform sizes.

In all public buildings lifts are to be provided for the conveniences of old and disabled persons. In hostels G + 3 floors can be built without lifts, but in residential flats maximum floors permitted without lifts is only G + 2. Lift is to be located near the entrance. Size of the lift is decided by the number of users in peak hours. Lifts are available with capacity 4 to 20 persons.

9. Finishing: Bottom portion of slab (ceiling), walls and top of floor need smooth finishing with plaster. Then they are provided with white wash, distemper or paints or tiles. The function of finishing work is:

- (a) Give protective cover
- (b) Improve aesthetic view
- (c) Rectify defective workmanship
- (d) Finishing work for plinth consists in pointing while for floor it consists in polishing.

10. Building Services: Water supply, sanitation and drainage works, electric supply work and construction of cupboards and show cases constitute major building services.

For storing water from municipal supply or from tanker a sump is built in the house property near street. From the sump water is pumped to over head tanks placed on or above roof level so as to get water all the 24 hours. Plumbing work is made so as to get water in kitchen, bathrooms, water closets, sinks and garden taps.

For draining rain water from roofs, down take pipes of at least 100 mm diameters should be used. Proper slopes should be given to roof towards down take pipe. These pipes should be fixed at 10 to 15 mm below the roof surface so that rain water is directed to the down take pipe easily.

The sanitary fittings are to be connected to stone ware pipes with suitable traps and chambers. Stone ware pipes are then connected to underground drainage of municipal lines or to the septic tank.

Many carpentry works are required for building service. They are in the form of showcases, cupboards, racks etc.

Electric supply is essential part of building services. The building should be provided with sufficient points for supply of lights, fans and other electric gadgets.

2.1.1.2 Basic requirements of a building

The planning and construction of a building should be aimed at fulfilling the following requirements:

1. Strength and stability
2. Dimensional stability
3. Resistance to dampness
4. Resistance to fire
5. Heat insulation
6. Sound insulation
7. Protection against termite attack
8. Durability
9. Security against burglary
10. Lighting and ventilation
11. Comforts and convenience
12. Economy.

1. Strength and Stability: Building should be capable of transferring the expected loads in its life period safely to the ground. Design of various structural components like slabs, beams, walls, columns and footing should ensure safety. None of the structural components should buckle, overturn and collapse.

2. Dimensional Stability: Excessive deformation of structural components give a sense of instability and result into crack in walls, flooring etc. All structural components, should be so designed that deflections do not exceed the permissible values specified in the codes.

3. Resistance to Dampness: Dampness in a building is a great nuisance and it may reduce the life of the building. Great care should be taken in planning and in the construction of the building to avoid dampness.

4. Resistance to Fire: Regarding achieving resistance to fire, the basic requirements laid down in the codes are:

- (a) the structure should not ignite easily.
- (b) building orientation should be such that spread of fire is slow.
- (c) In case of fire, there should be means of easy access to vacate building quickly.

5. Heat Insulation: A building should be so oriented and designed that it insulates interior from heat.

6. Sound Insulation: Buildings should be planned against outdoor and indoor noises.

7. Protection from Termite: Buildings should be protected from termites.

8. Durability: Each and every component of the building should be durable.

9. Security against Burglary: This is the basic need the owner of the building expects

10. Lighting and Ventilation: For healthy and happy living natural light and ventilations are required. Diffused light and good cross ventilation should be available inside the building.

11. Comforts and Conveniences: Various units in the building should be properly grouped and integrated keeping in mind the comfort and convenience of the user.

12. Economy: Economy without sacrificing comfort, convenience and durability is another basic requirement of the building.

2.1.1.3 PLANNING

All buildings should be properly planned, keeping in view the various requirements of a good building. Except strength requirement, all other requirements of a good buildings are taken care at the stage of planning. Strength requirement is taken care during structural design of building components. However in planning the building by-laws of the statutory authorities should not be violated. Planning of the building is an art combined with science.

Principles of planning of buildings may be grouped into:

1. Orientation
2. Energy efficiency
3. Utility
4. Other requirements of the building.

2.1.1.4 Planning suitable orientation

Orientation means setting out the plan of the building with respect to north-south and east-west directions to provide an opportunity to user to enjoy sun-shine and breeze when required and to avoid the same whenever not required. This is also known as planning the aspect of a building. Aspect means arrangement of doors, windows in the external wall to make good use of nature. This term has nothing to do with the architectural aspect of outlook of building. Kitchen should have eastern aspect to enjoy morning sunshine, means, kitchen should be located on the eastern side of the building to make use of morning sun rays. The following are the required aspects for various parts of the building in the northern hemisphere of earth:

- (a) Kitchen—eastern aspect.
- (b) Dining room—southern aspect to enjoy winter sun.
- (c) Drawing and living room—southern or south-eastern aspect to enjoy winter sun. (d) Bed rooms—western or south-western aspect to enjoy breez in summer.
- (e) Reading room, class room, stairs, northern aspect to enjoy diffused light.

2.1.1.5 Planning for energy efficiency

A building should be planned in such a manner that it gives maximum day lighting, ventilation and heat insulation. If these requirements are fulfilled, requirement of electric energy comes down.

(a) Light: Natural light provides hygienic atmosphere. Light should not be glaring but it should be uniformly distributed. Providing windows and ventilators of appropriate size at suitable positions contributes a lot for natural lighting. For residential buildings window area to floor area should not be less than 1/10th while for school buildings it should not be less than 1/5th of floor area. For factory buildings north light trusses should be provided to get maximum diffused light.

(b) Ventilation: Ventilation is the circulation of the air in the building. Natural ventilation can be achieved by selecting and positioning of doors, windows and ventilators at suitable places. Always cross ventilations should be planned suitably. Provision of ventilators at roof level helps in driving out hot airs. In case it is not possible to achieve natural ventilation for any part of the building provide ordinary or exhaust fans.

(c) Heat Insulation: Thicker exterior walls provide insulation against heat. Proper ventilation also helps in achieving heat insulation. Sun shades provided to doors, windows and ventilators help in achieving heat insulation. In factories and assembly halls height should be more to reduce temperature inside the building. The position of furnaces in the factories should be located away from the other parts of the factory. The openings should be provided at higher level in the wall to remove hot air.

2.1.1.6 Planning for suitable utility

Principles of planning for suitable utility are:

1. Roominess
2. Furniture Requirements
3. Groupings
4. Circulation.

2.1.1.7 Planning for meeting other requirements

Principle of planning involves planning for meeting the following requirements also:

1. Sanitary convenience
2. Prospects
3. Elegance
4. Flexibility
5. Privacy
6. Resistance to fire
7. Sound insulation
8. Protection from termite
9. Security against burglary
10. Economy
11. Provisions for future alterations.

2.2 Conventional spread footings

This type of foundations is commonly used for walls and masonry columns. These foundations are built after opening the trenches to required depth. Such footings are economical up to a maximum depth of 3 m. As these foundations are suitable depth, they are grouped under *shallow foundations*.

Figure 2.2.1 shows a conventional spread footing for a wall and Fig. 2.2.2 shows it for a masonry column.

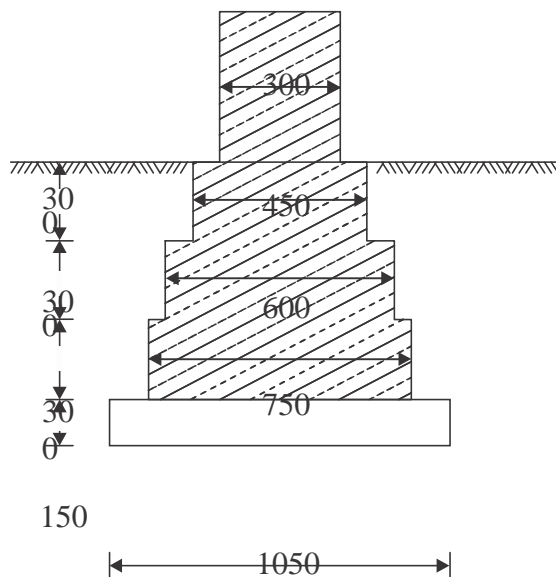

Fig. 2.2.1. Wall footing

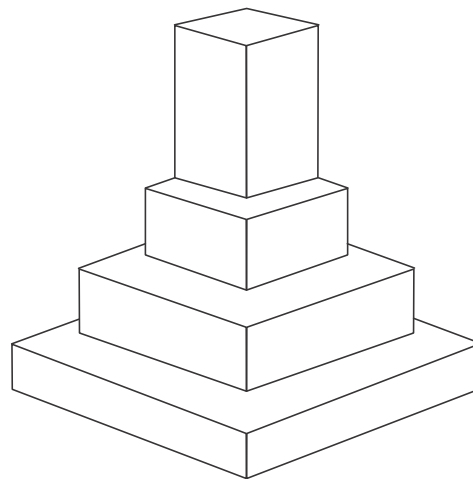

Fig. 2.2.2 Foundation for masonry pier

Before building these footing trenches are opened to required depth and the soil is rammed well. Then a plain concrete of mix 1 : 4 : 8 is provided. Its thickness varies from 150 to 200 mm. Over this bed, stone masonry footing is built. It is built in courses each course projecting 50 to 75 mm from the top course and height of each course being 150 to 200 mm. In case of wall footing the projections are only one direction while in case of columns, they are in both directions. The projection of bed concrete from the lowest course of foundation masonry is usually 150 mm.

2.2.2 R.C.C. footings

There are mainly two types of R.C.C. footings:

1. One way reinforced footings.
2. Two way reinforced footings.

1. One Way Reinforced Footing: These footings are for the walls. In these footings main reinforcements are in the transverse direction of wall. In longitudinal directions there will be only nominal reinforcement.

2. Two Way Reinforced Footings: For columns two way reinforced footings are provided. The following types of the footings are common:

(i) Isolated Column Footings: If separate footings are provided for each column, it is called isolated column footing. Figure 2.2.2.1 shows a typical isolated column footing. The size of footing is based on the area required to distribute the load of the columns safely over the soil. These footings are provided over a 100 to 150 mm bed concrete. Required reinforcements and thickness of footing are found by the design engineers. Thickness may be uniform or varying.

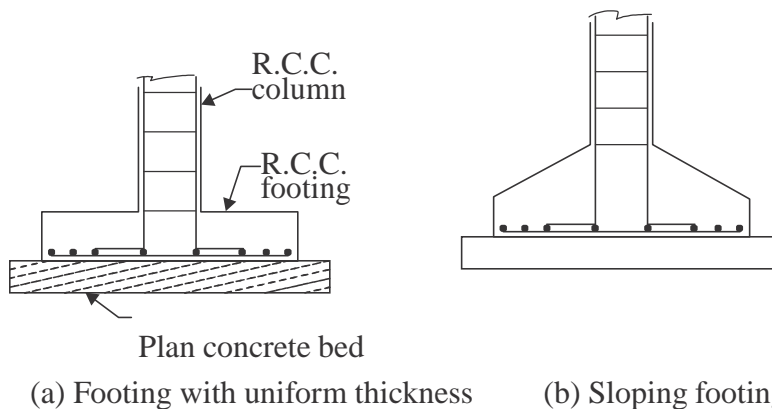

(a) Footing with uniform thickness (b) Sloping footing

Fig. 2.2.2.1 Isolated R.C.C. footing

(ii) Combined Footings: Common footings may be provided for two columns. This type of footing is necessary when a column is very close to the boundary of the property and hence there is no scope to project footing much beyond the column face. Figure 2.2.2.2 shows a typical combined footing. The footing is to be designed for transferring loads from both columns safely to the soil. The two columns may or may not be connected by a strap beam.

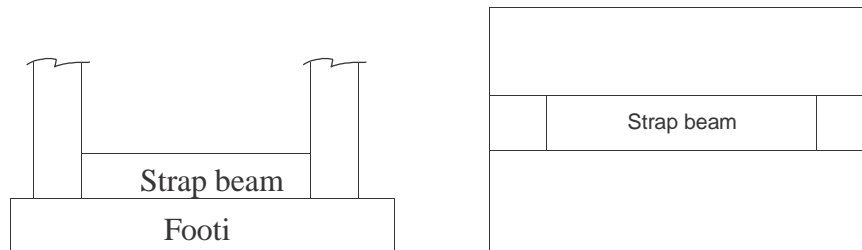

Fig. 2.2.2.2. Combined footing [Strap beam may or may not be provided]

(iii) Continuous Footings: If a footing is common to more than two columns in a row, it is called continuous footing. This type of footing is necessary, if the columns in a row are closer or if SBC of soil is low. Figure 2.2.2.3 shows this type of footing.

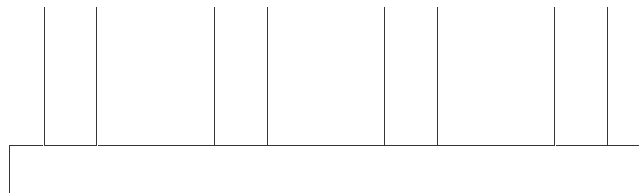

Fig.2.2.2.3 Continuous footing

(iv) Mat Footing/Raft Footing: If the load on the column is quite high (Multistorey columns) or when the SBC of soil is low, the sizes of isolated columns may work out to be to such an extent that they overlap each other. In such situation a common footing may be provided to several columns as shown in Fig. 2.2.2.4 Such footings are known as raft footings.

If the beams are provided in both directions over the footing slab for connecting columns, the raft foundations may be called as grid foundation also.

The added advantage of such footing is, settlement is uniform and hence unnecessary stresses are not produced.

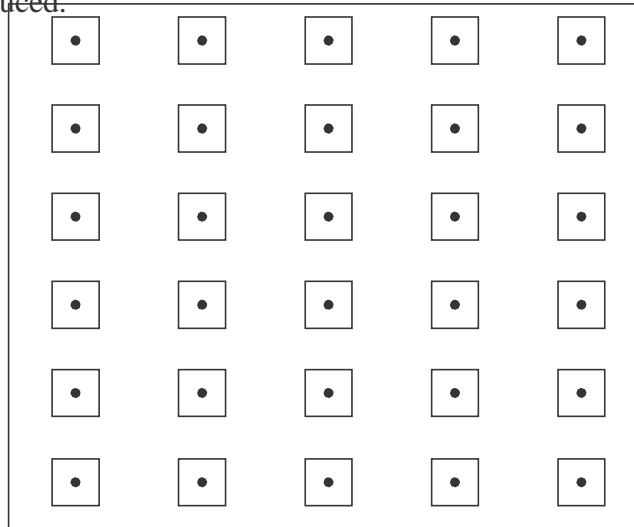
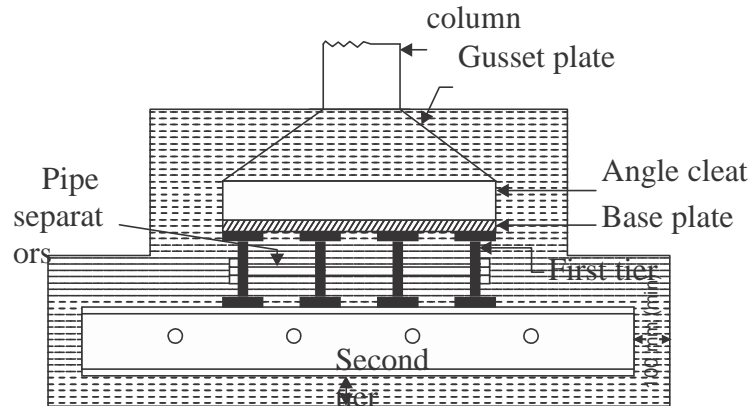

Fig.2.2.2.4 Raft foundation

2.2.2.1 Grillage footing

High rise buildings are built with steel columns encased in concrete. Such columns carry very heavy load and hence they need special foundations to spread the load to a larger area of soil. Grillage foundation is one such special foundation. It consists of one tier or more tiers of I-sections steel beams. Fig 2.2.2.5 shows a typical two tier grillage foundation. Top tier consists of less number but large size steel section while lower tier consists of larger number but smaller size steel sections. Column load is transferred to the top tier through a base plate. The grillage beams are unpainted and are encased in concrete with minimum cover of 100 mm beyond the edges of steel sections. A minimum clear space of 75 mm should be maintained between the flanges of adjacent grillage beams so that concreting can be made properly. To maintain spacing, pipe separators are used.

Steel Fig. 2.2.2.5
Grillage foundation



150 mm

(a) Section of AB.

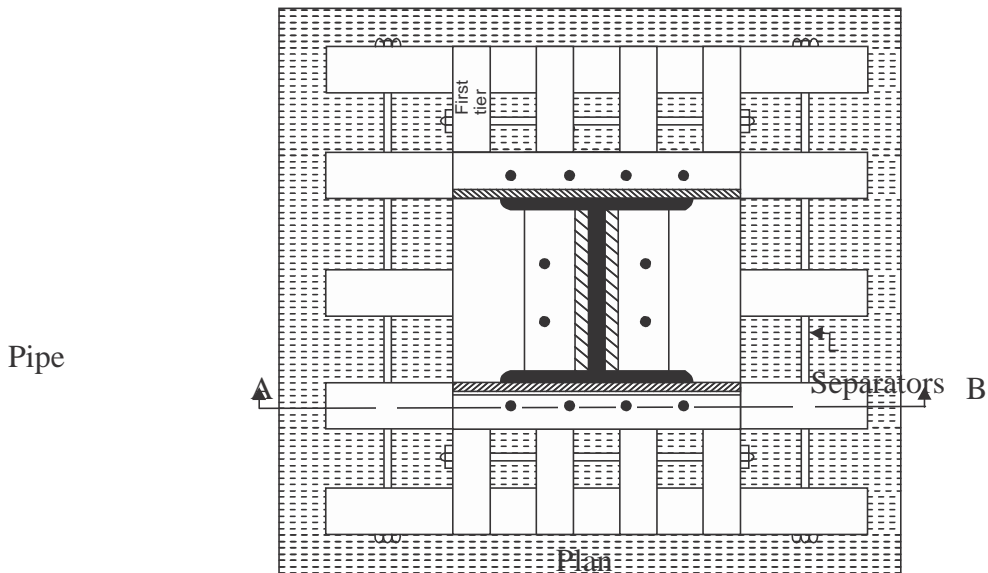

2.2.3 Arch foundation

Inverted arch foundations are provided in the places where the SBC of the soil is very poor and the load of the structure is through walls. In such cases inverted arches are constructed between the walls. End walls should be sufficiently thick and strong to withstand the outward horizontal thrust due to arch action. The outer walls may be provided with buttress walls to strengthen them. Figure 2.2.3.1 shows a typical inverted arch footing.

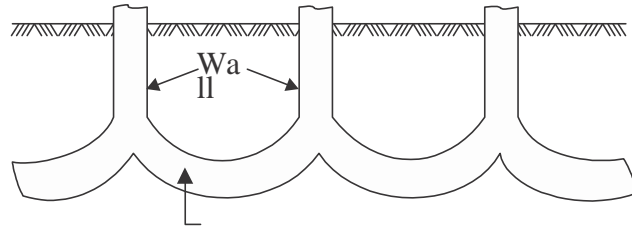

Inverted arch
Fig. 2.2.3.1 Inverted arch footing

2.2.4 Pile foundations

These foundations are known as deep foundations. A pile is a slender column made of wood, concrete or steel. A pile is either driven into the soil or formed in situ by excavating a hole and then filling it with concrete. A group of piles are driven to the required depth and are capped with R.C.C. slab, over which super structure is built. The pile transfer the load to soil by friction or by direct bearing, in the latter case, piles being taken up to hard strata. This type of foundations is used when top soil is not capable of taking the load of the structure even at 3-4 m depth.

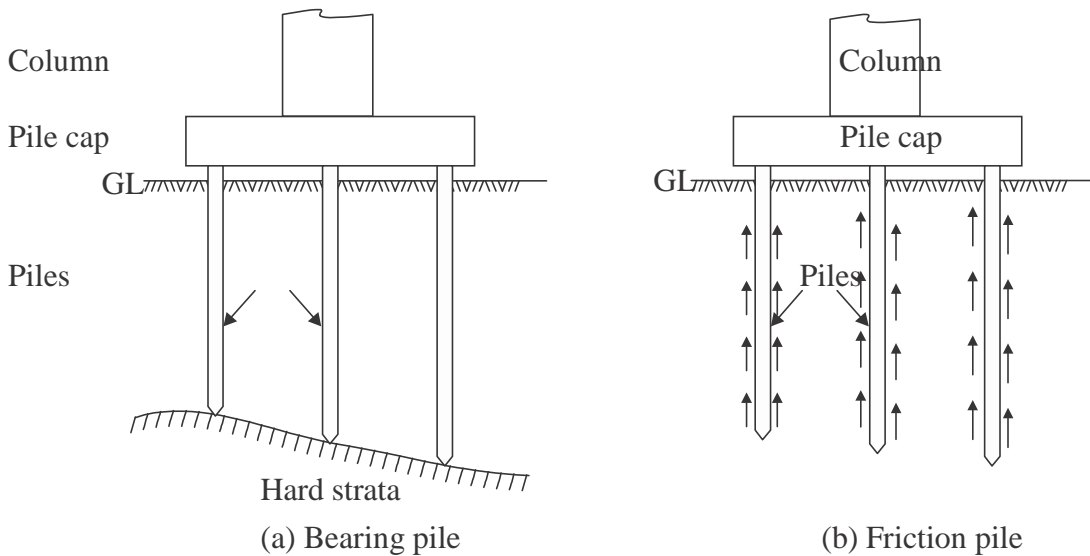

(a) Bearing pile (b) Friction pile
Fig. 2.2.4.1 Pile foundations

Pile foundations are classified according to the materials used and also on the nature of load transfer.

Classification According to Materials Used:

Piles may be classified as:

- (a) Timber piles
- (b) Concrete piles
- (c) Steel piles and
- (d) Composite piles.

(a) Timber piles: Circular seasoned wood can be used as piles. Their diameter may vary from 200 mm to 400 mm. Similarly square piles of sizes 200 mm to 400 mm are also used. The length of timber pile should not be more than 20 times its lateral dimension. The bottom of the pile is sharpened and is provided with iron shoe, so that it can be driven in the ground easily by hammering. These piles should be always kept below water table; otherwise alternating wet and dry condition cause the decay. These piles are cheap and can be easily driven rapidly. The main disadvantage is their load carrying capacity is low and are likely to be damaged during driving in the soil.

(b) Concrete piles: These piles may be further classified as precast piles and cast in situ piles. *Precast piles* are reinforced with steel and are manufactured in factories. The cross-section diameter/dimension varies from 200 mm to 500 mm. Square, circular and octagonal sections are commonly used. The length of piles may be up to 20 m. They are provided with steel shoe at the lowest end. These piles can carry fairly large loads. These piles are highly resistant to biological and chemical actions of the soil. The disadvantage of these piles is they need more time to manufacture and are heavy to handle.

Figure 2.2.4.2(a) and (b) show concrete piles.

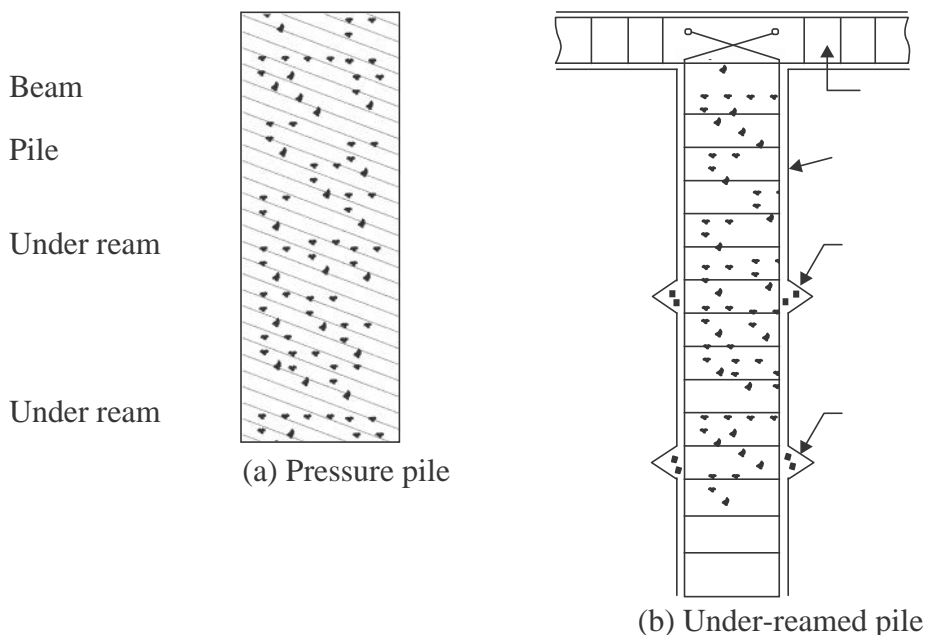

Fig. 2.2.4.2. Cast in situ concrete pile

Cast in situ concrete piles are formed first by boring the holes in the soil and then concreting them. Concreting is usually made using casing tubes. If the hole is filled with only plain concrete it is pressure pile. The load carrying capacity of the piles may be increased by providing enlarged base.

The reinforcement caging may be inserted in the bored holes and to increase load carrying capacity one or two under reams may be formed. After that concreting may be carried out. Such piles are known as under reamed piles. These piles are provided at regular interval of 2 to 4 m and capping beam is provided over them.

(c) Steel Piles: A steel pile may be a rolled steel I sections, tubes or fabricated in the form of box. These piles are mostly used as bearing piles since surface available for friction is less and also the coefficient of friction is less. If tubes are used the soil inside the tube is driven out by compressed air and concrete is filled. These piles are very useful for driving close to existing structures since they disturb the soil least.

(d) Composite Piles: Composite piles may be of concrete and timber or of concrete and steel. Wooden piles should not be subjected to alternating wet and dry conditions. Hence they are preferred for the portion below water table. The portion above water table are built with cast in situ concrete piles.

If the required length of steel piles is less than the depth of pile, many times upper portions are built with concrete. Thus steel and concrete composite piles are sometimes used.

Classification of Piles According to Load Transfer:

According to the load transfer to the soil piles may be classified as

- (a) Bearing piles and
- (b) Friction piles.

Bearing piles rest on hard strata and transfer the load by bearing. Such piles are preferred. These piles are used if the hard strata are available at reasonable depth.

Friction piles transfer the load to the soil by the friction between soil and the pile. Such piles are used if hard strata are not available to a considerable depth. The friction developed is to be properly assessed before deciding the length of the pile. The surface of such piles is made rough to increase the skin friction so that required length of pile is reduced.

2.2.2.5 Stone masonry

Masonry means construction of buildings using building blocks like stone, bricks, concrete blocks etc. Masonry is used for the construction of foundation, plinth, walls and columns. Mortar is the binding material for the building blocks. In this article different types of stone masonry used are explained and points to be observed while supervising stone masonry works are listed.

Types of Stone Masonry

Mainly there are two types of stone masonry:

1. Rubble Masonry
2. Ashlar Masonry.

1. Rubble Masonry: In this type of constructions stones of irregular sizes and shapes are used. To remove sharp shapes they may be hammered. The rubble masonry may be *coursed* or *uncoursed* [Fig. 2.2.2.5.1 and 2.2.2.5.2]. In *uncoursed rubble masonry* the wall is brought to level at every 300 mm to 500 mm. The mortar consumed in these construction is more. Course rubble masonry is used for the construction of public and residential buildings. Uncoursed rubble masonry is used for the construction of foundations, compound walls, garages, labour quarters etc. A skilled mason may arrange the facing stones in *polygonal shapes* to improve the aesthetic of the wall.

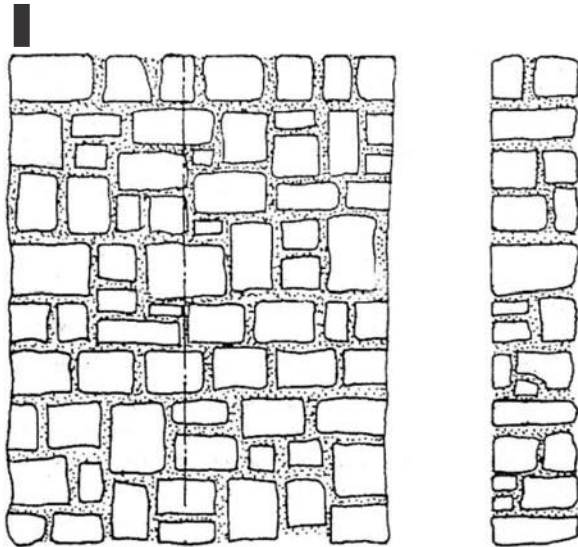

(a) Elevation (b) Section x – x
Fig.2.2.2.5.1 Uncoursed rubble masonry

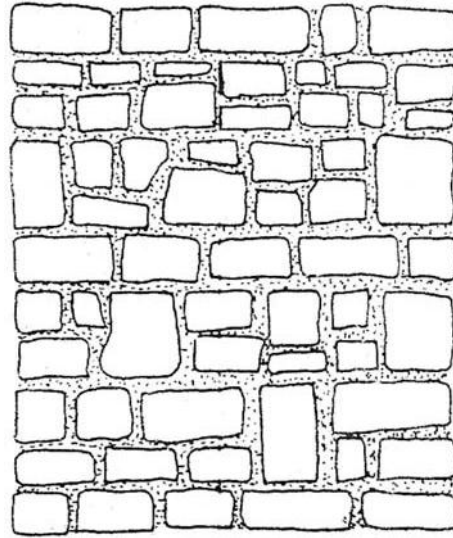
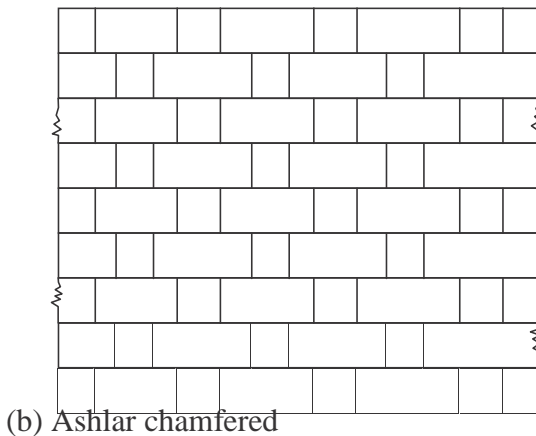

Fig. 2.2.2.5.2 Coursed rubble masonry

2. Ashlar Masonry: In this type of masonry stones are dressed to get suitable shapes and sizes. The height of the stones varies from 250 mm to 300 mm. The length should not exceed three times the height. The dressing of the stone need not be very accurate on all sides. Usually good dressing is made on facing side. In such construction mortar consumption is less compared to rubble masonry.

There are different types of ashlar masonry depending upon the type of dressing such as Ashlar fine dressed, Ashlar rough dressed, Ashlar rock or quarry faced, Ashlar facing, Ashlar chamfered etc. Figure 8.3 show some of such masonry



(a) Fig.2.2.2.5.3 Fine finished ashlar

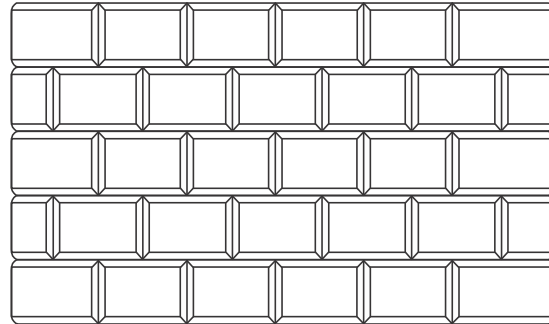

Fig.2.2.2.5.4 Ashlar masonry

Supervision of Stone Masonry Construction

The following points should be kept in mind in supervising stone masonry work:

1. Hard and durable stones, free from defects like flaws, cavities veins etc. should be used.
2. Dressing of the stones should be as per the requirement.
3. Stones should be properly wetted before they are used so as to avoid sucking of water from mortar.
4. Stones should be laid on their natural bed.
5. Facing and backing faces should be laid neatly and levelled and checked with wooden template.
6. The heart of masonry should be filled with stone chips and mortars. To thick mortar joints should be avoided.
7. Verticality of the wall should be frequently checked with plumb-bob.
8. Mortars with correct proportion of sand and cement should be used.
9. Continuous vertical joints should be avoided.
10. Through stones should be used within 1.5 m distances.
11. The height of masonry should be raised uniformly.
12. Under the beams, trusses, sills etc large flat stones should be used.
13. Before continuing work, the masonry built on previous day should be well cleaned and freed from loose particles.
14. Curing should be done properly for 2 to 3 weeks.

2.6 Brick masonry

Brick masonry is built with bricks bonded together with mortar. For temporary sheds mud mortar may be used but for all permanent buildings lime or cement mortars are used.

The various types of bonds generally used in brick masonry are

1. Stretcher bond
2. Header bond
3. English bond and
4. Flemish bond.

1. Stretcher Bond: A stretcher is the longer face of the brick as seen in the elevation. In the brick of size 190 mm × 90 mm × 90 mm, 190 mm × 90 mm face is the stretcher. In stretcher bond masonry all the bricks are arranged in stretcher courses as shown in Fig. 2.6.1 However care should be taken to break vertical joints. This type of construction is useful for the construction half brick thick partition wall.

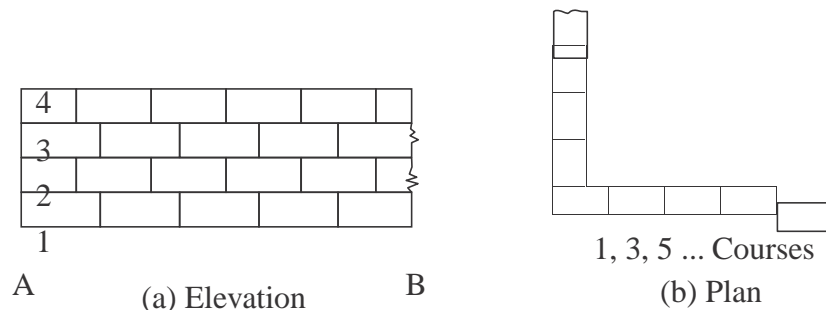

Fig. 2.6.1 Stretcher

bond

2. Header Bond: A header is the shorter face of the brick as seen in the elevation. In a standard brick it is 90 mm × 90 mm face. In header bond brick masonry all the bricks are arranged in the header courses as shown in Fig. 2.6.2. This type of bond is useful for the construction of one brick thick wall

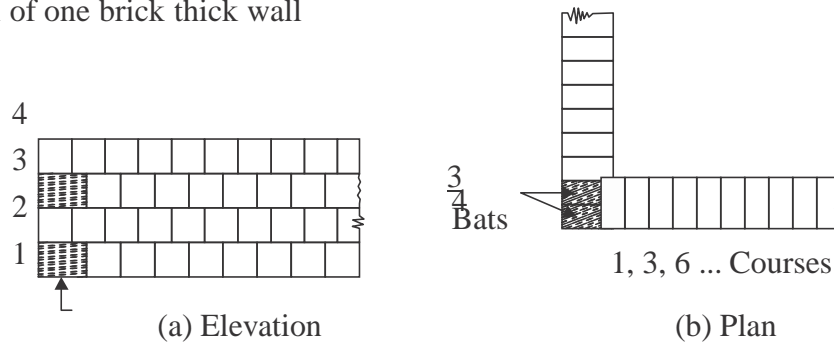

Fig. 2.6.2 Header bond

3. English Bond: In this alternate courses consist of headers and stretchers. This is considered to be the strongest bond. Hence it is commonly used bond for the walls of all thicknesses. To break continuity of vertical joints a brick is cut lengthwise into two halves and used in the beginning and end of a wall after first header. This is called queen closer. Figure 2.6.3 shows typical one brick and one and half brick thick wall with English bond.

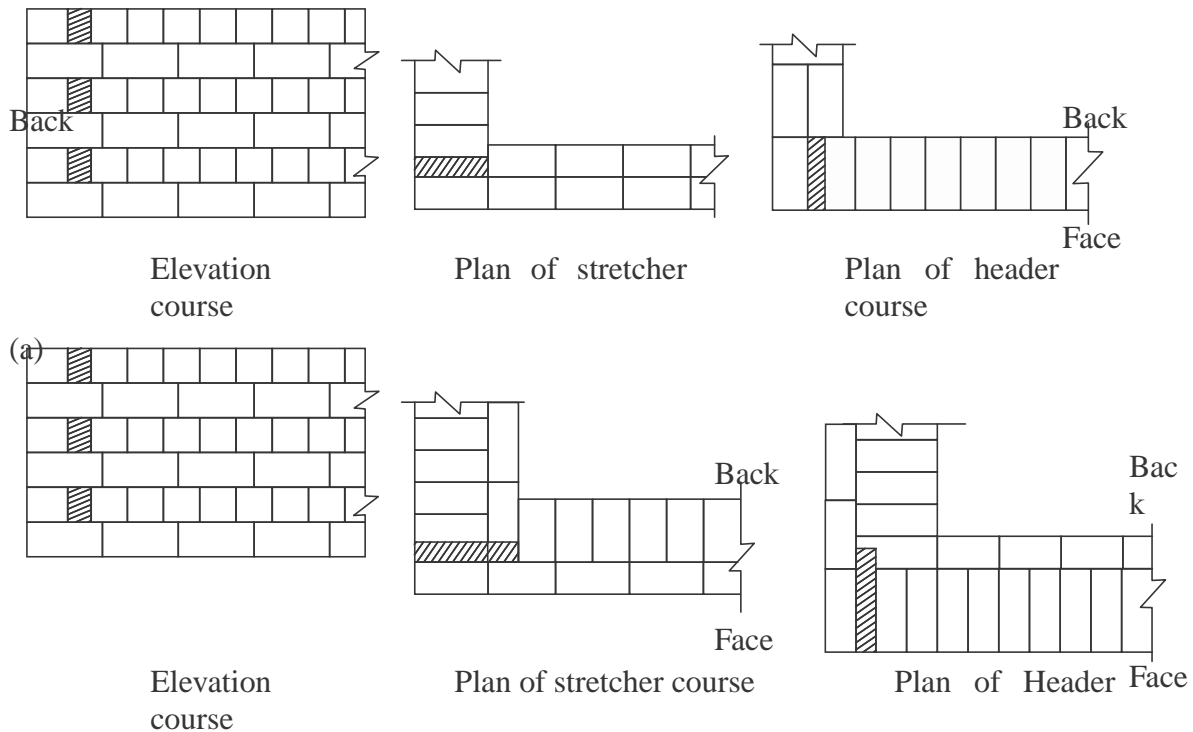

Fig. 2.6.3 English bond

4. Flemish Bond: In this type of bond each course comprises of alternate header and stretcher fig 2.6.4 Alternate courses start with stretcher and header. To break the vertical joints queen closers are required, if a course starts with header. Every header is centrally supported on the stretcher below it.

Flemish bonds may be further classified as

- (a) Double Flemish Bond
- (b) Single Flemish Bond.

In case of *double flemish bond*, both faces of the wall have flemish look, *i.e.* each course consist of alternate header and stretcher, whereas *single flemish bond* outer faces of walls have flemish look whereas inner faces have look of English bond

Construction of flemish bond needs greater skill. It gives more pleasing appearance. But it is not as strong as English bond. If only pointing is to be used for finished wall, flemish bond may be used to get good aesthetic view. If plastering is going to be used, it is better to use English bond.

The following points should be observed in the construction of brick masonry:

1. Use bricks of good quality with uniform colour, well burnt, with exact shape and size.
2. Before using the bricks in masonry, they should be soaked in water for 2 hours so that bricks do not absorb water from the mortar.
3. Bricks should be laid with the frog pointing upward.
4. Construction of brick wall should start from the end or corner.
5. Brick courses should be perfectly horizontal.
6. Verticality of the wall should be ensured by frequently checking with plumb-bob.
7. Mortar used should be as per specification.
8. Whenever work is stopped brick masonry should be left with toothed end.
9. Use of brick bats should be avoided.
10. Walls should be raised uniformly. In no case difference between adjoining walls be more than 1 m. In a day no wall should be raised by more than 1.5 m.
11. To get proper key for plastering or pointing, the face joints should be raised to a depth of 12 to 20 mm, when the mortar is green. If plastering or pointing is not to be provided, face joints should be stuck flush and finished neatly.
12. Holdfasts for doors and windows should be embedded in brick masonry with cement mortar or concrete, at the time of constructing the wall itself.
13. Brick masonry should be regularly cured for 2 weeks.
14. For carrying out brick work at higher levels, only single scaffolding should be used.

Advantages and Disadvantages of Brick Masonry Over Stone Masonry***Advantages:***

1. Since shape and size of bricks are uniform, it do not need skilled labour for the construction.
2. Bricks are light in weight and hence handling them is easy.
3. Bricks are easily available around cities and their transportation cost is less because their weight is less. Stones are to be brought from quarries which are located only at few places.
4. It is possible to use all types of mortar in brick masonry. For unimportant buildings even mud mortar can be used.
5. Thinner walls can be constructed with bricks but it is not so with stones.
6. It is easy to form openings for doors and windows.
7. Dead load of brick masonry is less.
8. In brick masonry mortar joints are thin and hence construction cost is reduced considerably.
9. Brick masonry has better fire and weather resistance compared to stone masonry.

Disadvantages:

1. Strength of brick masonry is less than that of stone masonry.
2. Durability of brick masonry is less.
3. Brick masonry needs plastering and plastered surface needs colour washing. Stone masonry don't need them and hence maintenance cost is more in brick masonry.
4. Brick masonry absorbs water and there are possibility of dampness. There is no such problem in stone masonry.
5. More architectural effects can be given in stone masonry compared to that in brick masonry.
6. Stone masonry gives massive appearance and hence monumental buildings are built in stone masonry.

2.7 Beams

Beams are defined as horizontal load carrying member in a structure. Reinforced cement concrete, concrete, prestressed concrete and steel I sections are used as beams to support the slabs.

Classified:

- ✓ Simply supported beam
- ✓ Rigidly fixed beam
- ✓ Cantilever beam
- ✓ Over hanging beam
- ✓ Continuous beam

Simply supported beam:

If the ends of a beam are supported freely by columns it is called simply supported beam

Rigidly fixed beam:

If the two ends of a beam is rigidly fixed in walls then it is called fixed beams. In such cases, the moment is induced at supports because it will not allow rotation.

Cantilever beam:

If a beam is fixed in one end and the other end is free then it is called cantilever beam.

Overhanging beam:

If a beam having its end portion extended beyond the support, it is called overhanging beam.

Continuous beam:

If a beam is supported on more than two supports, then it is known as continuous beam.

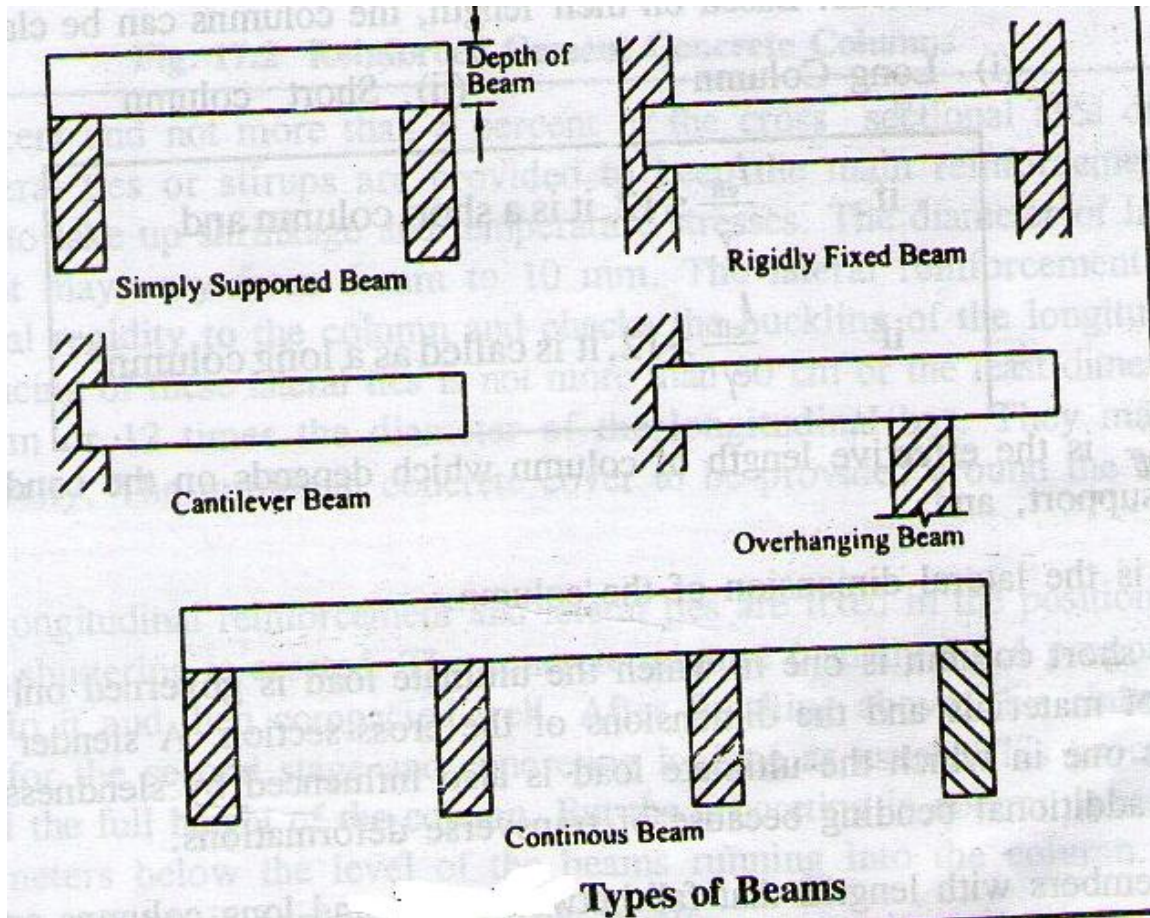

2.8 Columns

The vertical load carrying member of a structure is called column. They are constructed of timber, stone, reinforced cement concrete or steel section.

Classified:

- ✓ Long column
- ✓ Short column

Long column

The ratio of effective length to least later dimension is less than 12 called as long column

Short column

The ratio of effective length to least later dimension is more than 12 called as long column

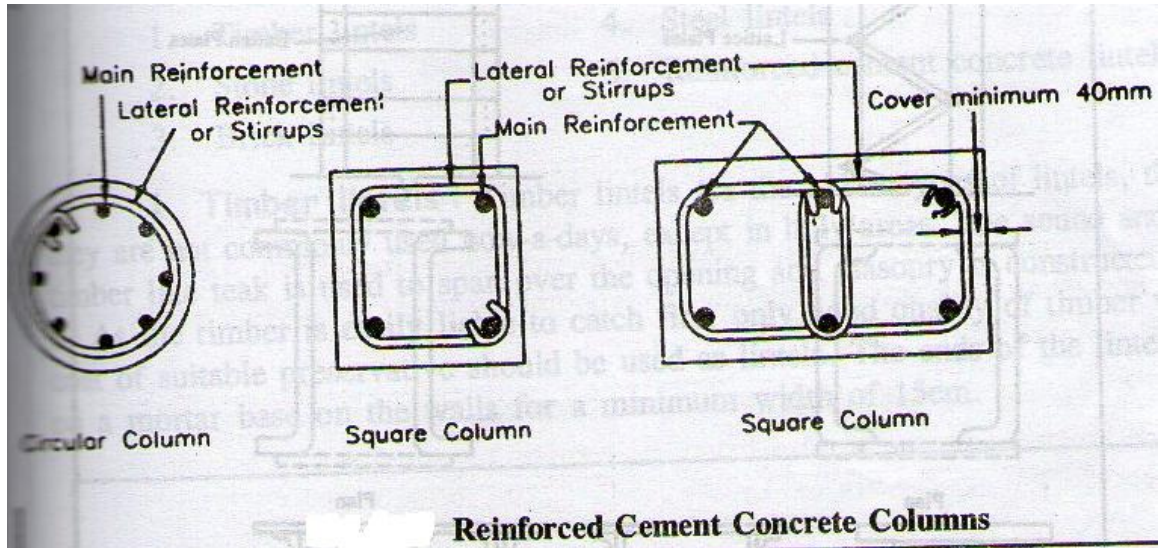

Reinforced cement concrete column

Usually the reinforced cement concrete column are cast in-situ type. They may be constructed in square, rectangular, circular shapes. Vertical reinforcements or main reinforcements are provided to take up major load coming over the column. Generally the diameter of vertical reinforcement may vary from 10mm to 40mm. Longitudinal reinforcement bars should not be less than 0.8% and not more than 6% of the cross sectional area of the column. The diameter of lateral reinforcement may vary from 6mm to 10mm.

In the multi storied buildings, the section of the column in upper stories may be reduced as they have to carry lesser loads. But the centre lines of various columns of different stories must coincide in a same vertical line.

Steel columns

The various cross sections of steel columns are shown in fig. Struts of one or two angles are used as compression member in roof trusses. Latticed columns made up of channels or angles connected by lattice bars are often used where light loads are to be supported on long columns. battened columns made up of channels or angles connected only batten plate are also used as column. Rolled H-columns which are available in depths ranging from 150 mm to 500 mm and are now commonly used in steel Skelton construction

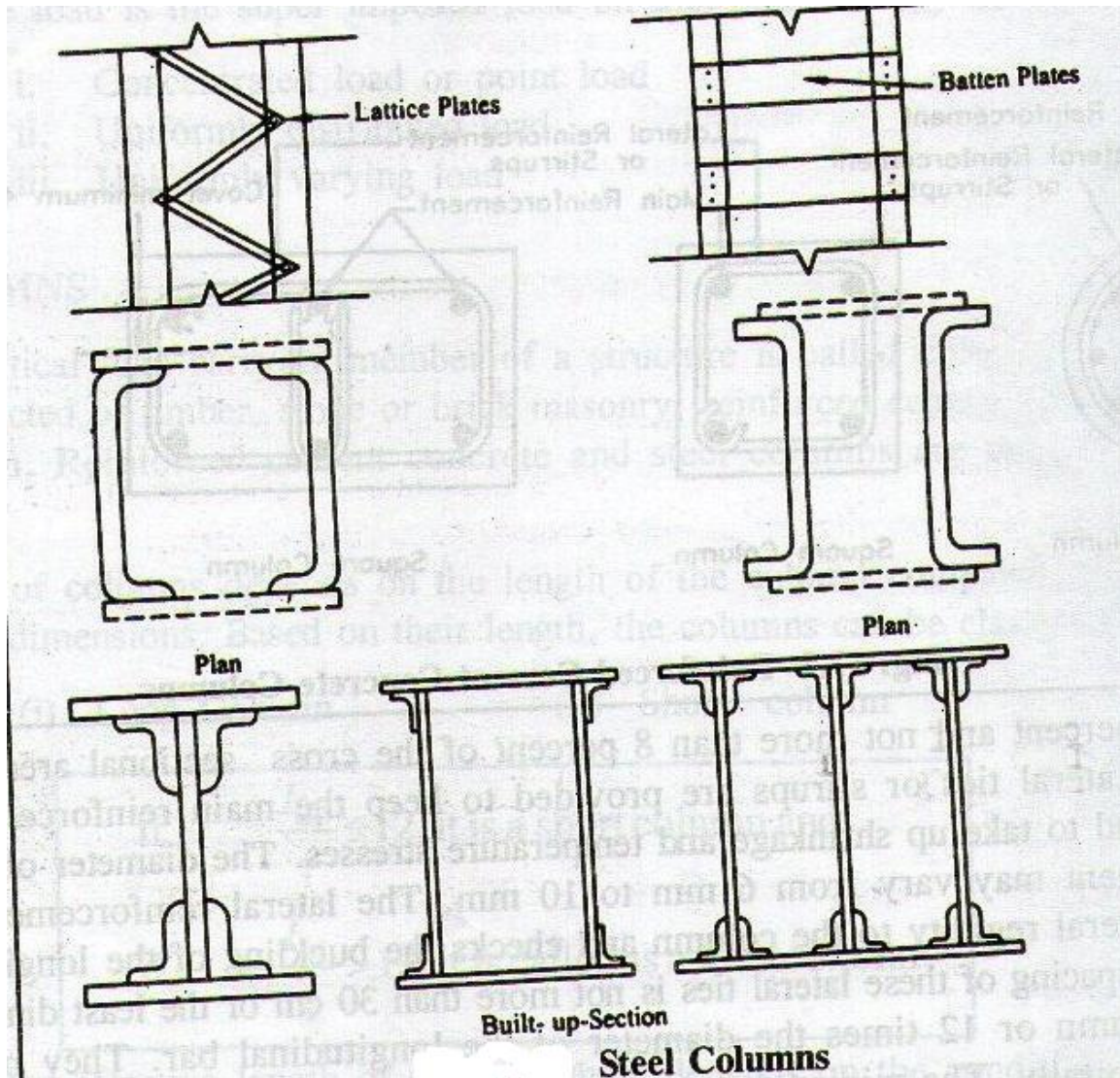

2.9 Lintels

A lintel is a horizontal member which is placed across the openings. Openings are invariably left in the wall for the provision of doors, windows etc. A lintel is thus a sort of beam, the width of which is equal to the width of the wall, and the ends of which are built into the wall.

Classification

- ✓ Timber lintels
- ✓ Stone lintels
- ✓ Brick lintels
- ✓ Steel lintels
- ✓ Reinforced cement concrete lintels

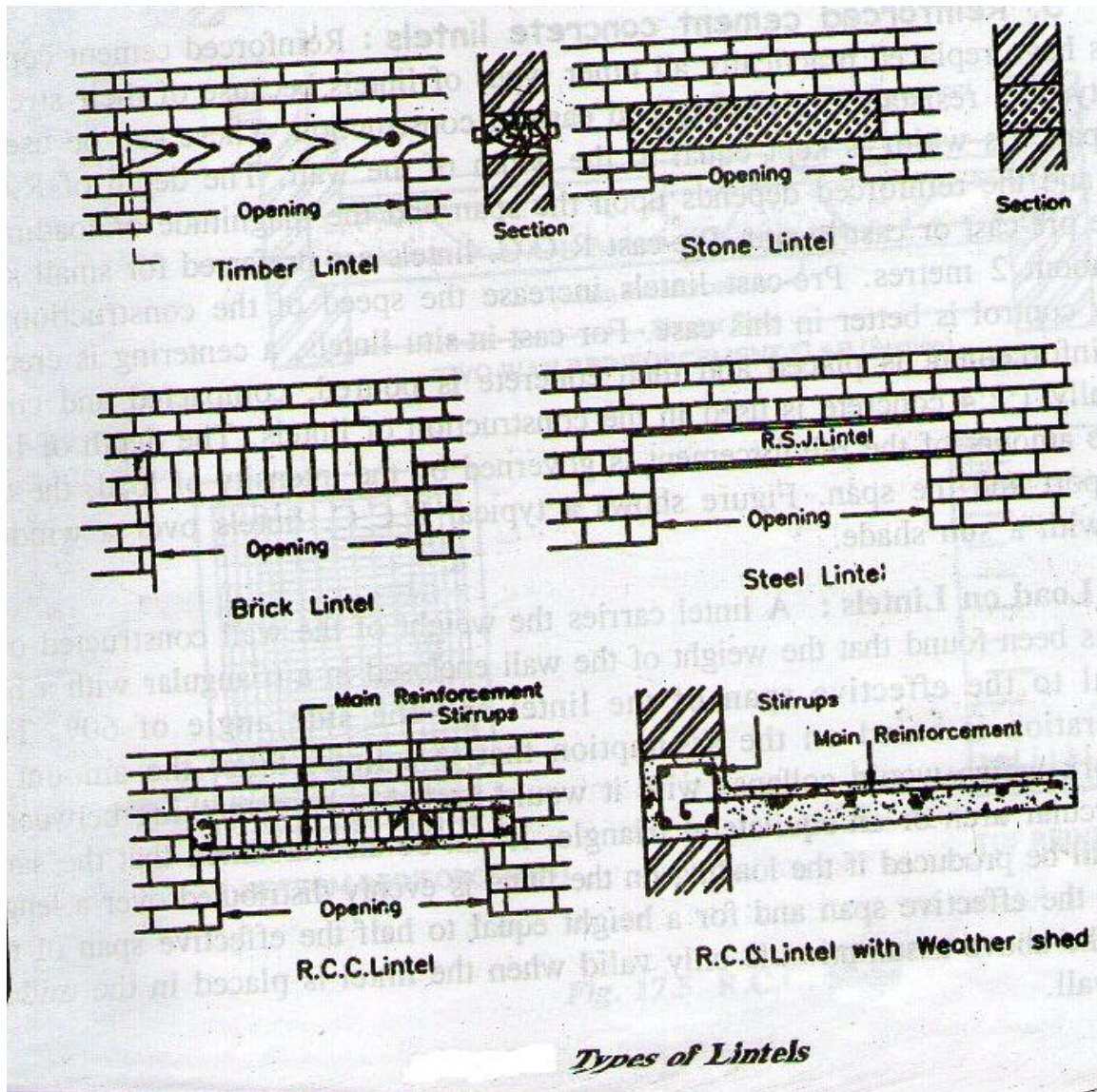

Timber lintels are the oldest types of lintels, though they are not commonly used now-a-days, except in hilly areas. The sound and hard it. As the timber is easily liable to catch fire, only good quality is constructed over coat of suitable preservative should be used as lintels.

Stone lintels

Stone lintels are used in stone masonry structures. This consists of a simple stone slab of greater thickness. Stone lintels can also be provided over openings in brick walls.

Brick lintels

Brick lintels are not structurally strong and they are used for small openings, generally not exceeding not exceeding 1 meter span, and light loads. They are built up with hand well burnt, copper colored, free from cracks and with sharp and straight edged bricks.

Steel lintels

Steel lintels are provided where the opening is large and the super imposed loads are also heavy. It consists of rolled steel joists or channel sections.

Reinforced cement concrete lintels

Reinforced cement concrete lintels have replaced practically all other types of lintels because of their strength, rigidity, fire resistance economy and ease in construction. Its width is kept equal to the width of the wall. The depth of R.C.C lintel and the reinforcement depends upon the span and magnitude of loading. It can be pre-cast or cast-in-situ, pre-cast R.C.C lintels are preferred for small spans up to about 2 meters. The depth of lintel and the reinforcement is governed by the intensity of load, the type of support and the span.

3.0 Flooring

Purpose of flooring is to get a good hard, level and beautiful surface for living. The floors directly resting on the ground are known as ground floors while the floors of each storey are known as upper floors.

Ground Floor

Apart from giving good finished surface, these floors should have good damp resistance. The ground surface is rammed well and a layer of red earth or sand is placed which is compacted. A layer of broken bricks, stones etc. is provided up to 150 mm below floor finish level and rammed. While ramming the surface is kept moist to get good compaction. Then 1 : 4 : 8 concrete of 100 to 150 mm thickness is provided as base course. Over this bed floor finish is laid.

The types of flooring used are:

- | | |
|-------------------|--------------------|
| 1. Mud and moorum | 2. Brick |
| 3. Flag stone | 4. Cement concrete |
| 5. Terrazo | 6. Mosaic |
| 7. Marble | 8. Tiles |
| 9. Timber | 10. Rubber |
| 11. P.V.C. | |

1. Mud and Moorum Flooring: These floorings are used in low cost housing, specially in villages. Over the hard layer of earth filling mud or moorum layer is provided. The floor needs a thin wash of cow dung at least once a week.

2. Brick Flooring: This is also a cheap floor construction. It is commonly used in godowns and factories. Bricks are laid flat or on edges. Bricks of good quality should be used for the construction. Brick layer is provided on sand bed or on lean concrete (1 : 8 : 16) bed. In both cases joints are rendered flush and finished with cement mortar.

3. Flag Stone Flooring: Laminated sand stones or slates of 20 mm to 40 mm thick in the form of slabs of 300 mm × 300 mm or 450 mm × 450 mm or in the form of rectangles of size 450 mm × 600 mm are used as floor finishes. The stone slabs are laid on 20 to 25 mm thick mortar spread over concrete bed. The joints are to be finished with rich mortar.

4. Cement Concrete Floors: It is modestly cheap and durable floor and hence commonly used in residential, commercial and industrial buildings. It consists of two courses—base course and wearing coat. Base course is laid over well compacted soil. Its thickness is usually 75 mm to 100 mm. It consists of lean cement concrete mix (1 : 4 : 8) or lime concrete containing 40% of 1 : 2 lime mortar and 60% of coarse aggregate of 40 mm size. After base course is hardened wearing coat of 40 mm is laid. It consists of panels of 1 m × 1 m, 2 m × 2 m or 1 m × 2 m. Alternate panels are laid with 1 : 2 : 4 concrete using wooden, glass or asbestos strip separators of 1.5 mm to 2.0 mm thickness.

To get good bond between base course and wearing coat cement slurry wash is given before laying wearing coat panels. After 3–4 days of laying of one set of panel, another alternate panels are laid. Top of these panels are finished by tamping the surface with wooden floats and tapping with trowels, till cement slurry appears on top. It needs curing for 7 to 14 days. To get good appearance many times red-oxide finishing coat is provided.

5. Terrazo Flooring: Terrazo finishing coat is applied over concrete flooring to get pleasing appearance. Terrazo finish consists of 75 to 80% of surface marble chips embedded in cement mortar.

Marble chips are mixed in cement in the proportion 1 : 1.25 to 1 : 2 and about 6 mm terrazo topping is laid. The top is tamped and rolled. Additional marble chips are spread during tamping to get proper distribution of marble chips on the surface. After drying it for 12 to 20 hours, it is cured for 2–3 days.

Then grinding is made in the following three steps:

Ist grinding—Using coarse grade (No. 60) carborundum stones.

IInd grinding—Using medium grade (No. 120) carborundum stones.

IIIrd grinding—Using fine grade (No. 320) carborundum stones.

Plenty of water is used during grinding. After each grinding cement grout of cream-like consistency is applied and cured for 6–7 days. After final grinding and curing the floor is washed with plenty of water and then with dilute oxalic acid solution. Then floor is finished with polishing using machines and wax polish.

6. Mosaic Flooring: It consists of a finishing coat of small pieces of broken tiles of China glazed or of marble arranged in different patterns set in lime-surkhi or cement mortar. The base course is concrete flooring and on it 30 to 40 mm mortar layer is provided. On this mortar layer broken pieces of China glazed or marble are set to get different attractive patterns. After 20 to 24 hours of drying the top is rubbed with carborundum stone to get smooth and polished surface.

7. Marble Flooring: Marble slabs are cut to get marble tiles of 20 to 25 mm thickness. They are laid on floors similar to other tiles. With power driven machine surface is polished to get even and shining surface. This type of flooring is widely used in hospitals and temples.

8. Tiled Flooring: This is an alternative to terrazo flooring, used commonly used in residential, office and commercial buildings. Tiles of clay, cement or terrazo of standard sizes are manufactured in factories under controlled conditions. On the concrete base, 25 mm to 30 mm thick mortar is laid and these tiles are placed and pressed with trowel

or wooden mallet. Before placing tiles care is taken to see that, neat cement slurry is applied to bottom side and sides of tiles to get good bond. Next day joints are cleaned of loose mortar and raked up to 5 mm depth. Then that is filled with coloured cement slurry to get uniform colour on the top surface. After curing for 7 days grinding and polishing is made as in the case of terrazzo flooring.

9. Timber Flooring: Timber flooring are used in dancing halls and in auditoriums. Timber plates may be directly placed on concrete bed or may be provided over timber frame work. In latter case it is necessary to provide proper ventilation below the floor. This flooring is costly.

10. Rubber Flooring: Tiles or sheets of rubber with fillers such as cotton fibres, asbestos fibre or granulated cork are manufactured in variety of patterns and colours. These sheets or tiles may be fixed to concrete or timber floors. These floors are attractive and noise proof. However they are costly.

11. P.V.C. Flooring: Poly-Vinyl-Chloride (PVC) is a plastic which is available in different colour and shade. Nowadays tiles of this material are used widely. Adhesives are applied on concrete base as well as on bottom of PVC tiles. Then the tile is pressed gently with 5 kg wooden roller till the oozing of adhesive is seen. The oozed out adhesive is wiped and the floor is washed with warm soap water. The floor finish is smooth, attractive and can be easily cleaned. However it is slippery and costly.

3.1 Upper Floor

In olden days upper floors were made of *timber floors* or *steel joist and stone slabs*. For larger spans arch floorings were used. *Jack arch floor* consisted of I-section steel beams supported on walls and gap between I-sections beams filled with concrete arch. Figure 3.1.1 shows a typical jack arch flooring.

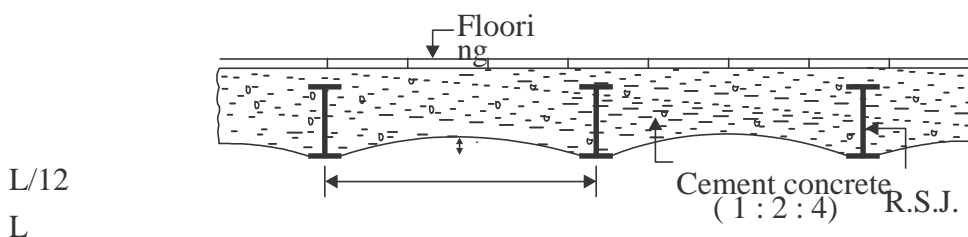

Fig. 3.1.1 Jack arch flooring

Nowadays *R.C.C. floors* are commonly used. It may consist of *only slab*, if span is less or it may be *beam and slab flooring*. In halls of hotels and assembly, many provide *flat slabs* i.e. slabs directly supported over columns.

The columns are provided with widened portion called column head. They give elegant look to halls, particularly when the head room is high. R.C.C. floors need proper thickness and reinforcements. They are arrived at by structural design engineers. Figure 3.1.2 shows typical R.C.C. slabs.

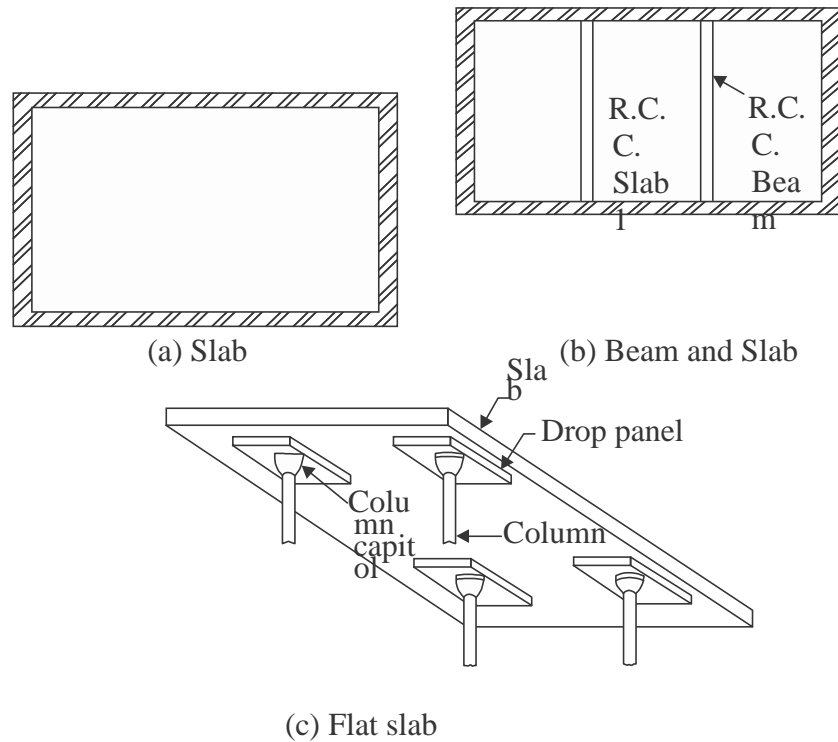

Fig. 3.1.2 R.C.C. floors

In R.C.C. concrete is used to resist compression and steel to resist tension. Hence the concrete in tension zone do not contribute in resisting the load. It just keeps the steel at required position. In *reinforced brick slab* an attempt is made to replace concrete in tension zone by bricks. It is better thermal efficient than solid concrete floors. Figure 3.1.3 shows a typical reinforced brick slab.

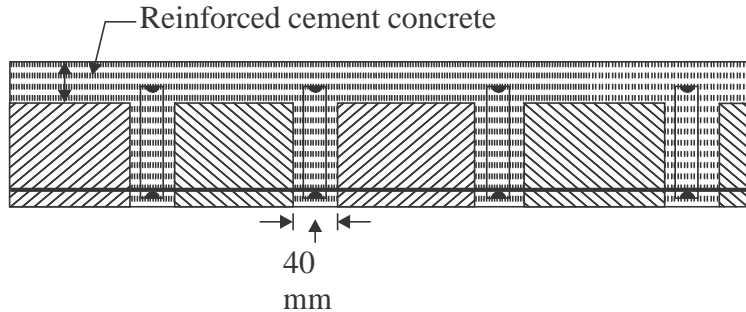

Fig. 3.1.3 Reinforced brick slab

In *ribbed or hollow tiled flooring*, the concrete in tension portion is replaced by hollow tiles. Figure 3.1.2 shows a typical floor of this type.

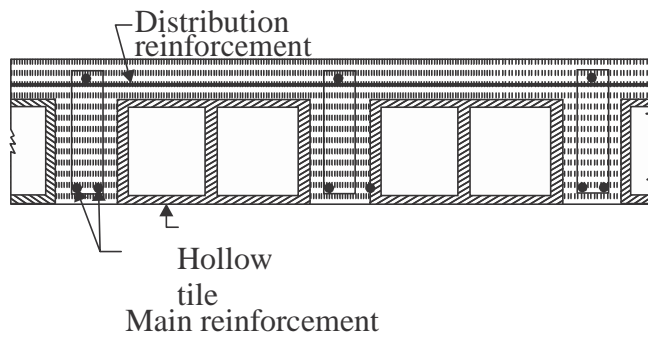

Fig. 3.1.2 Ribbed or Hollow tiled flooring

In precast concrete floor panels may be used which helps in avoiding form works, storing of sand, coarse aggregates etc. at the site and also curing. Factories manufacture these units which are to be placed over supports in the structure. Figure 3.1.4 shows the cross-section of a typical precast floor unit. These units are available in 0.25 m widths and in various spans. Interlocking grooves are provided on the sides to get tight connection with adjoining units.

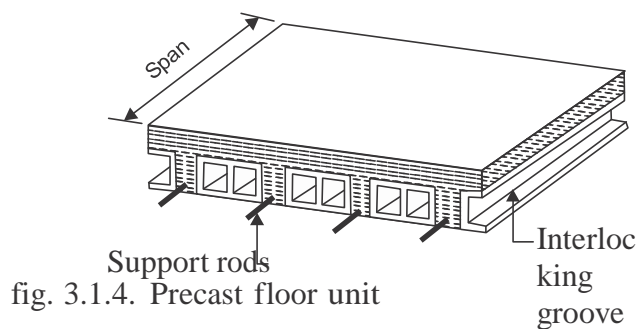

fig. 3.1.4. Precast floor unit

3.1 Roof

Roof is the upper most portion of the building which protects the building from rain, wind and sun. Various types of roofs used may be divided broadly into three types:

1. Flat roofs
2. Pitched roofs
3. Shells and folded plates.

Flat roofs are used in plains where rainfall is less and climate is moderate. Pitched roofs are preferred wherever rainfall is more. Shells and folded plate roofs are used to cover large column free areas required for auditoriums, factories etc. Brief description of these roofs is presented below:

1. Flat Roofs: These roofs are nearly flat. However slight slope (not more than 10°) is given to drain out the rain water. All types of upper storey floors can serve as flat roofs. Many times top of these roofs are treated with water proofing materials-like mixing water proofing chemicals in concrete, providing coba concrete. With advent of reliable water proofing techniques such roofs are constructed even in areas with heavy rain fall.

The *advantages* of flat roofs are:

- (a) The roof can be used as a terrace for playing and celebrating functions.
- (b) At any latter stage the roof can be converted as a floor by adding another storey.
- (c) They can suit to any shape of the building.
- (d) Over-head water tanks and other services can be located easily.
- (e) They can be made fire proof easily compared to pitched roof.

The *disadvantages* of flat roofs are:

- (a) They cannot cover large column free areas.
- (b) Leakage problem may occur at latter date also due to development of cracks. Once leakage problem starts, it needs costly treatments.
- (c) The dead weight of flat roofs is more.
- (d) In places of snow fall flat roofs are to be avoided to reduce snow load.
- (e) The initial cost of construction is more.
- (f) Speed of construction of flat roofs is less.

Types of Flat Roofs:

All the types listed for upper floors can be used as flat roofs.

2. Pitched Roofs: In the areas of heavy rain falls and snow fall sloping roof are used. The slope of roof shall be more than 10° . They may have slopes as much as 45° to 60° also. The sloped roofs are known as pitched roofs. The sloping roofs are preferred in large spanned structures like workshops, factory buildings and ware houses. In all these roofs covering sheets like A.C. sheet, G.I. sheets, tiles, slates etc. are supported on suitable structures.

The pitched roofs are classified into

- (a) Single roofs
- (b) Double or purlin roofs
- (c) Trussed roofs.

(a) **Single Roof:** If the span of roof is less than 5 m the following types of single roofs are used.

- (i) Lean to roofs
- (ii) Coupled roofs
- (iii) Coupled-close roof
- (iv) Collar beam roof

In all these roofs rafters placed at 600 mm to 800 mm spacing are main members taking load of the roof. Battens run over the rafters to support tiles. Figure 8.13 shows various types of single roofs.

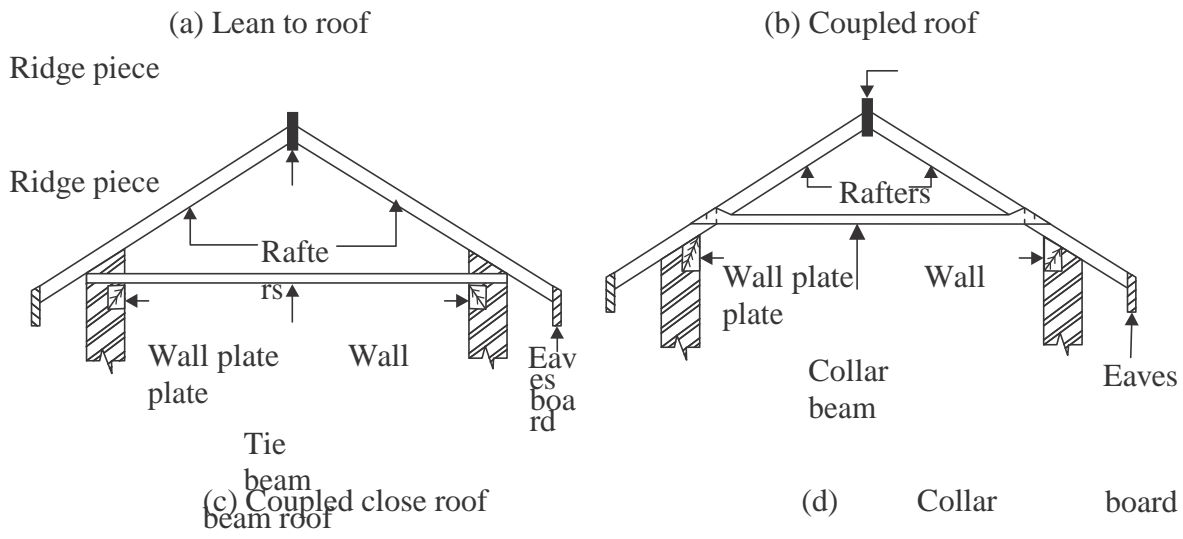

Fig.3.1.5. Single roofs

(b) Double or Purlin Roofs: If span exceeds, the cost of rafters increase and single roof becomes uneconomical. For spans more than 5 m double purlin roofs are preferred. The intermediate support is given to rafters by purlins supported over collar beams. Figure 3.1.6 shows a typical double or purlin roof.

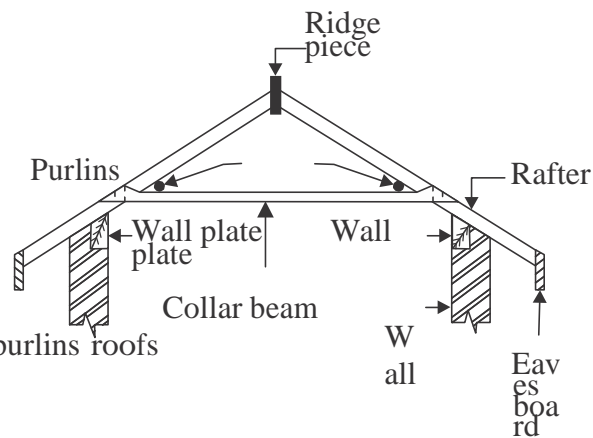
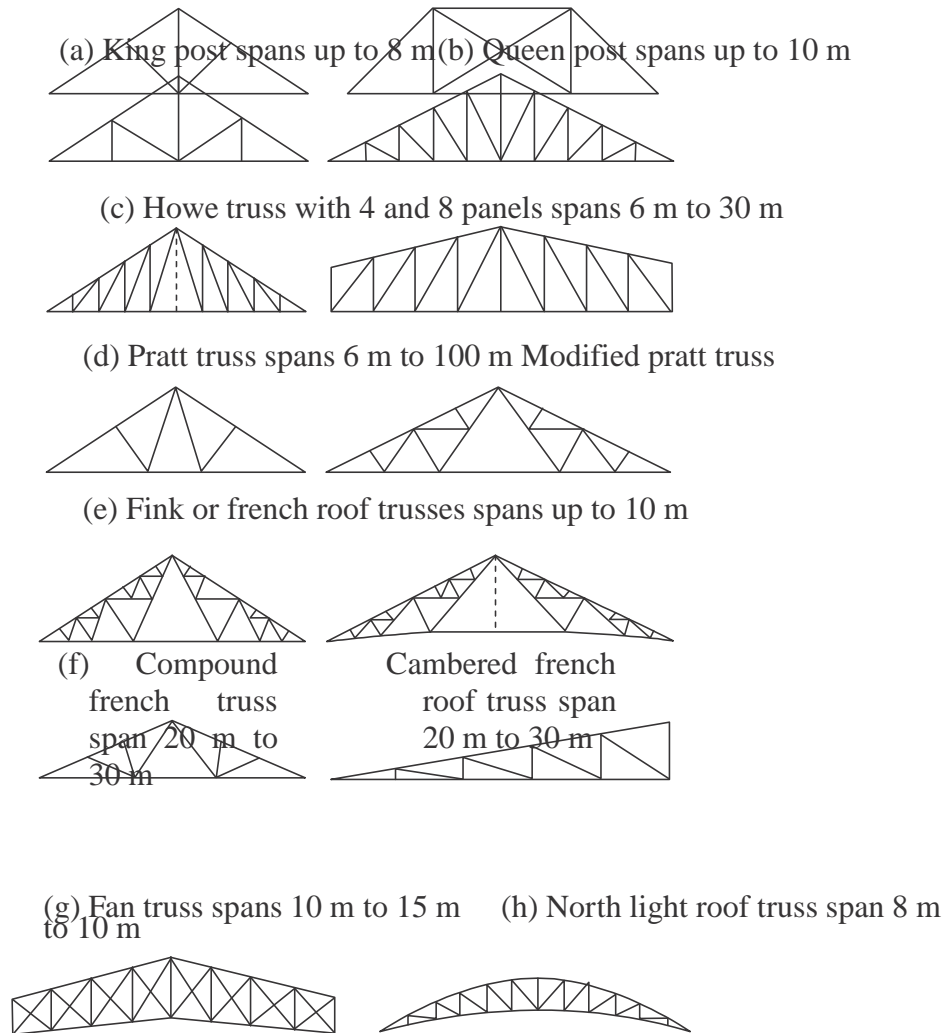

Fig. 3.1.6 Double or purlins roofs

(c) Trussed Roof: If span is more, a frame work of slender members are used to support sloping roofs. These frames are known as trusses. A number of trusses may be placed lengthwise to get wall free longer halls. Purlins are provided over the trusses which in turn support roof sheets. For spans up to 9 m wooden trusses may be used but for larger spans steel trusses are a must. In case of wooden trusses suitable carpentry joints are made to connect various members at a joint. Bolts and straps are also used. In case of steel trusses joints are made using gusset plates and by providing bolts or rivets or welding. Depending upon the span, trusses of different shapes are used. End of trusses are supported on walls or on column. Figure 3.1.7 shows different shapes of trusses used.



3. Shells and Folded Plate Roofs: *Shell roof* may be defined as a curved surface, the thickness of which is small compared to the other dimensions. In these roofs lot of load is transferred by membrane compression instead of by bending as in the case of conventional slab and beam constructions. Caves are having natural shell roofs. An examination of places of worships built in India, Europe and Islamic nations show that shell structures were in usage for the last 800 to 1000 years. However the shells of middle ages were massive masonry structures but nowadays thin R.C.C. shell roofs are built to cover large column free areas. Figure 3.1.8 shows commonly used shell roofs.

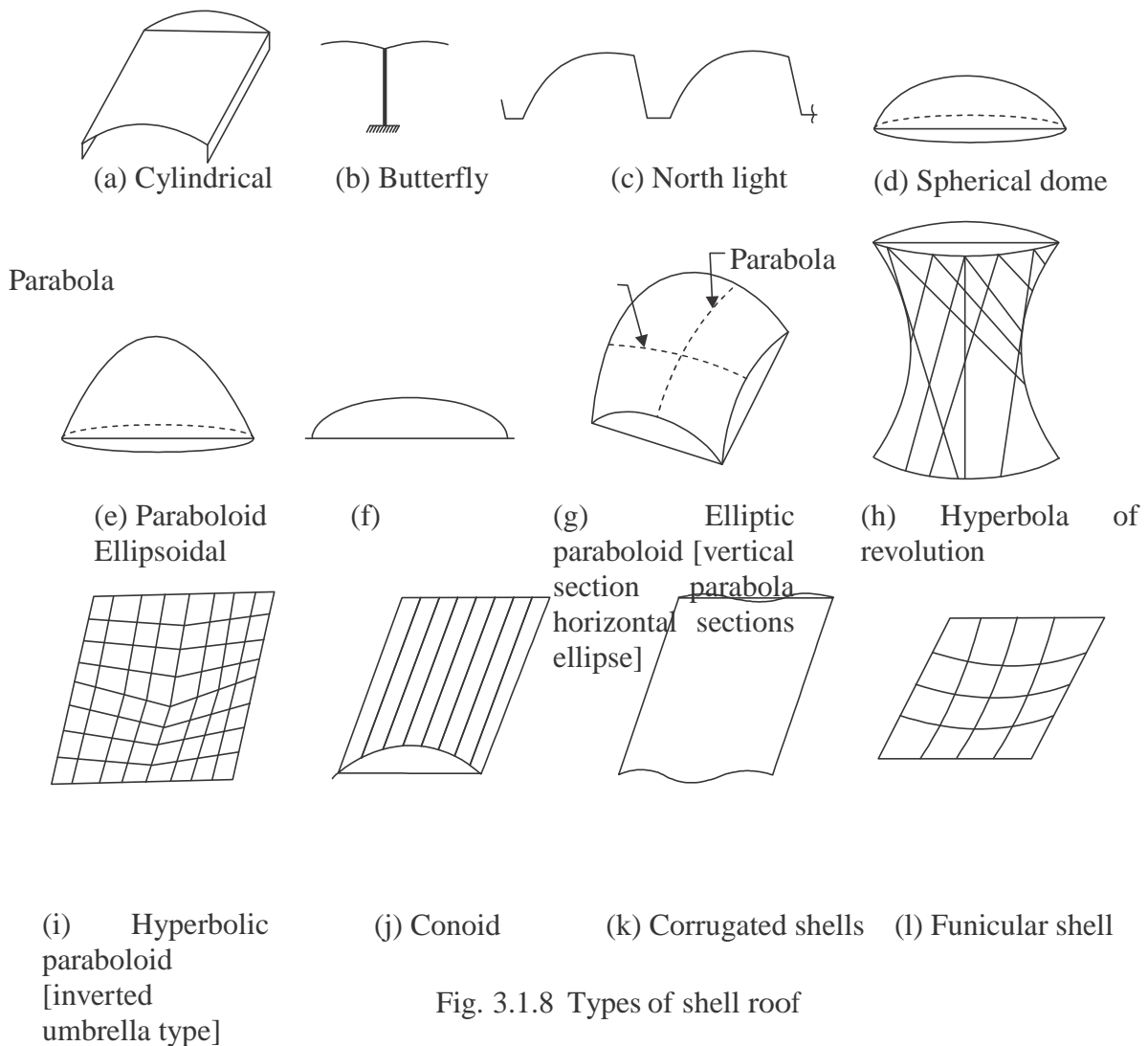

Fig. 3.1.8 Types of shell roof

Advantages and Disadvantages of Shell Roofs

Advantages of shell roofs are:

- (a) Good from aesthetic point of view
- (b) Material consumption is quite less
- (c) Form work can be removed early
- (d) Large column free areas can be covered.

Disadvantages are:

- (a) Top surface is curved and hence advantage of terrace is lost.
- (b) Form work is costly.

Folded plate roofs may be looked as slab with a number of folds. These roofs are also known as hipped plates, prismatic shells and faltwerke. In these structures also bending is reduced and lot of load gets transferred as membrane compression. However folded plates are not so efficient as shells. Figure 3.1.9 shows typical folded plate roofs.

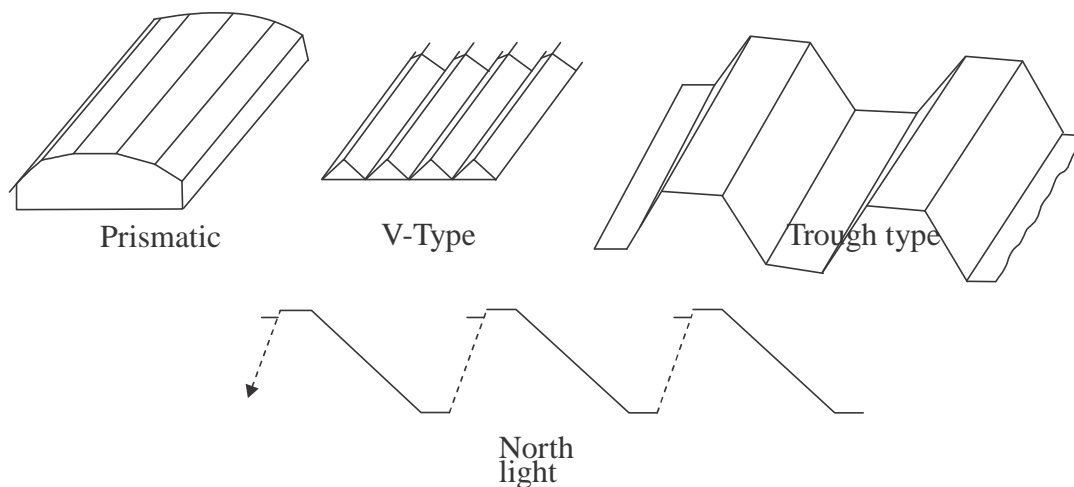

Fig. 3.1.9 Types of folded plate roofs

Advantages and Disadvantages of Folded Plate Roofs Over Shell Roofs

Advantages

- (a) Form work required is relatively simpler.
- (b) Movable form work can be employed.
- (c) Design involves simpler calculations.

Disadvantages are:

- (a) Folded plate consume more material than shells.
- (b) Form work can be removed after 7 days while in case of shells it can be little earlier.

3.1.1 Roof Coverings for Pitched Roofs

Various types of covering materials are available for pitched roofs and their selection depends upon the climatic conditions, fabrication facility, availability of materials and affordability of the owner. Commonly used pitched roof covering materials are:

- (a) Thatch
- (b) Shingle
- (c) Tiles
- (d) Slates
- (e) Asbestos cement (A.C.) sheets
- (f) Galvanised iron (G.I.) sheets

(a) Thatch Covering: These coverings are provided for small spans, mainly for residential buildings in villages. Thatch is a roof covering of straw, reeds or similar materials. The thatch is well-soaked in water or fire resisting solution and packed bundles are laid with their butt ends pointing towards eaves. Thickness varies from 150 mm to 300 mm. They are tied with ropes or twines to supporting structures. The supporting structure consists of round bamboo rafters spaced at 200 mm to 300 mm over which split bamboos laid at right angles at close spacing. It is claimed that reed thatch can last 50 to 60 years while straw thatch may last for 20–25 years.

The advantage of thatch roof is they are cheap and do not need skilled workers to build them. The disadvantages are they are very poor fire resistant and harbour rats and other insects.

(b) Shingles: Wood shingles are nothing but the split or sawn thin pieces of wood. Their size varies from 300 mm to 400 mm and length from 60 mm to 250 mm. Their thickness varies from 10 mm at one end to 3 mm at the other end. They are nailed to supporting structures. They are commonly used in hilly areas for low cost housing. They have very poor fire and termite resistance.

(c) Tiles: Various clay tiles are manufactured in different localities. They serve as good covering materials. Tiles are supported over battens which are in turn supported by rafters/trusses etc. Allahabad tiles, Mangalore tiles are excellent inter-locking tiles. They give good appearance also.

(d) Slates: A slate is a sedimentary rock. Its colour is gray. It can be easily split into thin sheets. Slates of size 450 mm to 600 mm wide, 300 mm long and 4 to 8 mm thick are used as covering materials of pitched roofs in the areas where slate quarries are nearby. A good slate is hard, tough, durable. They are having rough texture and they give ringing bell like sound when struck. They do not absorb water.

(e) A.C. Sheets: Asbestos cement is a material which consists of 15 per cent of asbestos fibres evenly distributed and pressed with cement. They are manufactured in sufficiently large size. The width of a A.C. sheet varies from 1.0 to 1.2 m and length from 1.75 to 3.0 m. To get sufficient strength with thin sections they are manufactured with corrugation or with traffords fib 3.20

They are fixed to the steel purlins using J-bolts. The roofing is quite economical, waterproof. However not very good thermal resistant. They are commonly used as covering materials in ware houses, godowns or for larger halls. In auditorium etc., if these sheets are used, false ceilings are provided to get good thermal resistance.

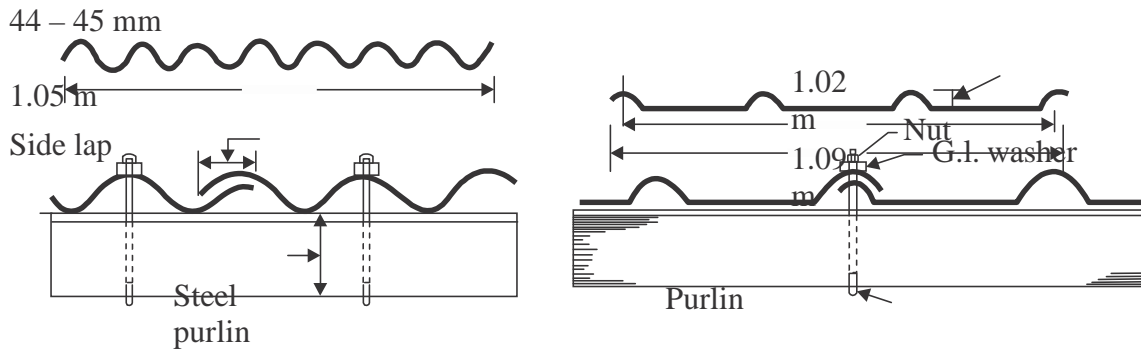

3.2 Plastering

Applying mortar coats on the surfaces of walls, columns, ceiling etc. to get smooth finish is termed as plastering. Mortar used for plastering may be lime mortar, cement mortar or lime-cement mortar. Lime mortar used shall have fat lime to sand ratio of 1 : 3 or 1 : 4. If hydraulic lime is used mix proportion (lime: sand) is 1 : 2. Cement mortar of 1 : 4 or 1 : 6 mix is very commonly used for plastering, richer mix being used for outer walls. To combine the cost effectiveness of lime mortar and good quality of cement mortar many use lime-cement mortar of proportion (cement : lime : sand) of 1 : 1 : 6 or 1 : 1 : 8 or 1 : 2 : 8.

The *objective* of plastering are:

1. to conceal defective workmanship
2. to give smooth surface to avoid catching of dust.

3. to give good look.
4. to protect the wall from rain water and other atmospheric agencies.
5. to protect surfaces against vermit.

Requirement of good plaster are:

1. It should adhere to the background easily.
2. It should be hard and durable.
3. It should prevent penetration by moisture
4. It should be cheap.

Lime mortar is usually applied in 3 coats while cement mortar is applied in two or three coats for the stone and brick masonry. For concrete surfaces cement mortar may be applied in two or three coats. For concrete building blocks many times only one coat of cement mortar is applied.

The first coat provides means of getting level surface. The final coat provides smooth surface. If three coats are used second coat is known as floating coat. The average thickness of first coat is 10 to 15 mm. Middle coat thickness is 6–8 mm. The final coat is just 2 to 3 mm thick. If single coat is used its thickness is kept between 6 to 12 mm. Such coats are used on concrete surfaces not exposed to rain.

3.3 Stress and strain

When a body is subjected to a system of external forces, it undergoes a deformation. At the same time, by virtue of its strength, it offers a resistance against this deformation. This internal resistance offered by the body to counteract the applied load is called stress.

The resistance per unit cross sectional area is called stress. The deformation in unit original dimension is termed as strain.

3.3.1 Types of stresses and strains

Tensile stress

When an external force produces elongation of the body in its direction, it is termed as tensile force.

P= External tensile load

R= Resistance induced in the material of the body

A=Cross sectional area

Tensile stress = Tensile load / Cross sectional area of the body

Tensile strain

Tensile strain = Increase in length / Original length

Compressive stress

When an external force causes shortening of the body in the direction of force, it is termed as a compressive force. The stress developed in the body due to a compressive force is called as compressive stress.

P= External compressive load

R=Resistance induced in the material of the body

A=Cross sectional area of the body

Compressive Stress = compressive load/ cross sectional area of the body

Compressive strain

Compressive strain = decrease in length/ Original length

Shear stress

When a body is subjected to two equal and opposite forces acting tangentially across the resisting section, as a result of which the body tends to shear off across the section, then this tangential force is termed as shear force and the stress induced is called shear stress.

Shear stress = Shear force/ Shear area

Shear strain

Shear strain = Transverse displacement/ Distance from the fixed base

Volumetric strain

The change in volume of an elastic body due to external force in unit original volume is called as the volumetric strain

Volumetric strain = dv/V

Lateral strain

When a material is subjected to uni-axial stress within the elastic limit, it deforms not only longitudinally but also laterally. Under tension the lateral dimensions diminish and under compression they increase. The lateral deformation per unit original lateral dimension is called lateral strain.

3.4 Elasticity

When an external force acts on a body, it undergoes some deformation. The property by which a body returns to its original shape after the removal of external load is elasticity.

3.4.1 Elastic limit

The limiting value of stress up to and within which the entire deformation disappears on removal of the external forces is called the elastic limit of the material. The body returns to its original shape after the removal of the loading when the intensity of stress is within a certain limit. The limit is called elastic limit.

3.4.2 Hooke's law

Hooke's law states that when an elastic material is stressed within elastic limit, the stress is proportional to the strain.

$$K = \text{stress/strain}$$

3.4.3 Young's Modulus

The ratio of the axial stress to the corresponding axial strain, with in elastic limit is called the young's modulus

$$E = \text{Axial stress/Axial strain}$$

3.4.4 Shear modulus

The ratio of the shear stress to the corresponding shear strain is a constant, which is called shear modulus

$$G = \text{Shear stress/shear strain}$$

3.4.5 Bulk Modulus

When a body is subjected to uniform direct stress in all the three mutually perpendicular direction, the ratio of the direct stress to the corresponding volumetric strain is found to be a constant which is called the bulk modulus

$$K = \text{direct Stress/ Volumetric Strain}$$

3.4.6 Poisson's ratio

$$\text{Poisson's ratio} = \text{Lateral strain/ Longitudinal Strain}$$

3.4.7 Relation between elastic constants

$$E = 2G (1 + \nu)$$

$$E = 3K (1 - 2\nu)$$

$$E = 9KG / 3K + G$$

E= Young's modulus

G= Shear modulus

K=Bulk modulus

R= poisson's ratio

3.4.8 Factor of safety

Factor safety = Ultimate stress/ Allowable stress

Problem

1. A mild steel rod of 12mm diameter and 200 mm length elongates 0.085 mm under an axial pull of 10kN. Determine the young's modulus of the material.

Load P= 10KN

Cross sectional Area = $(3.14 \times 12^2)/4$

Stress = $10000/113.1 = 88.4 \text{ N/mm}^2$

Strain = $0.085/200 = 4.25 \times 10^{-4}$

Young's modulus = $88.4 / 4.25 \times 10^{-4} = 2.08 \times 10^5 \text{ N/mm}^2$

2. A bar of 30 mm diameter is subjected to a pull of 60 kN. The measured extension on gauge length of 200 mm is 0.09 mm and the change in diameter is 0.0039 mm. Calculate the Poisson's ratio and the values of the three moduli.

Dia of bar d = 30mm

Area A= $3.14 \times 30^2 = 706.86 \text{ mm}^2$

Pull P = 60kN

Length l = 200 mm

Change in length = 0.09 mm

Change in diameter = 0.0039mm

Stress = $P/A = (60 \times 10^3) / 706.86 = 84.9 \text{ N/mm}^2$

$$\text{Strain} = P/E = 84.9/E$$

$$e = 0.09/200 = 0.00045$$

$$\begin{aligned} 84.9/E &= 0.00045 \\ &= 1.886 \times 10^5 \text{ N/mm}^2 \end{aligned}$$

Poisson's ratio

$$1/m = 0.00013/0.00045 = 0.289$$

Modulus of rigidity

$$G = (1.886 \times 10^5)/2(0.289 + 1) = 7.3157 \times 10^4 \text{ N/mm}^2$$

Bulk modulus

$$K = (1.886 \times 10^5)/3 (1 - (2 \times 0.289)) = 1.489 \times 10^5 \text{ N/mm}^2$$

3.5 BRIDGES

INTRODUCTION

A bridge is a structure providing passage over an obstacle without closing the way beneath.

The required passage may be for a road, a railway pedestrian or a canal of a pipeline. The obstacle to be crossed may be river, a road, a railway or a valley.

3.5.1 CLASSIFICATION OF BRIDGES

Bridges can be classified into various types depending upon the following factors:

Materials used for construction : Under this category bridges may be classified as:

- a) Timber bridges b) Masonry bridges
- c) Steel bridges d) Reinforced cement concrete bridges
- e) Pre-stressed concrete bridges f) Composite bridges

Alignment : Under this category, the bridge can be classified as

- a) Straight or square bridges and b) Skew bridges

Straight or square are the bridges which are at right angles to the axis of the river.

Skew bridges are not at right angles to the axis of the river.

The Relative position of bridge floor: Under this category, the bridge and classified as

- a) Deck bridge b) Semi through bridge and c) Through bridge

Deck bridges are the bridges whose floorings are supported at the top of the super structure. Through bridges are the bridges whose floorings are supported at the bottom of

the super structure. Semi-through bridges are the bridges whose floorings are supported at some intermediate level of the super structure.

Function of Purpose : Under this, the bridge can be classified as

- a) Highway bridge b) Railway bridge c) Foot bridge
- d) Viaduct and e) Aqueduct etc.

Position of High floor level : Under this, the bridges may be classified as

- a) Submersible bridge and b) Non-submersible bridge

Submersible Bridges are the bridges whose floor levels are below the high flood level. During flood seasons, it allows the water to pass over the bridge submerging the communication route. In economic point of view, these bridges are constructed.

Non-submergible bridges are the bridges whose floor levels are above the high flood level.

Life : Under this, the bridges may be classified as

- a) Permanent bridges b) Temporary bridges

Type of Superstructure : Under this, the bridges may be classified as

- a) Arch bridges b) Truss bridges
- c) Portal frame bridges d) Balanced cantilever bridges
- e) Suspension bridges etc.,

Span length : Under this category, the bridges can be classified as

- a) Culverts (span less than 6m)
- b) Minor bridges (span between 6 to 30m)
- c) Major bridges (span above 30m)
- d) Long span bridges (span above 120m)

Loading : Road bridges and culverts have been classified by Indian road congress into

- a) Class AA bridges b) Class A bridges
- c) Class B bridges according to the loadings they are designed to carry.

3.5.2 COMPONENT PARTS OF A BRIDGE

Broadly, a Bridge can be divided into two major parts.

1. Sub structure
2. Super structure

1. SUB STRUCTURE

The function of the sub structure is similar to that of foundations, columns and walls of a buildings, because it supports the super structure of the bridges and transmits the load safely to the ground.

The substructure consists of the following:

- a. Abutments
- b. Piers
- c. Wing walls
- d. Approaches
- e. Foundations for the piers and abutments

a. Abutments: The end of superstructure of a bridge is called abutments.

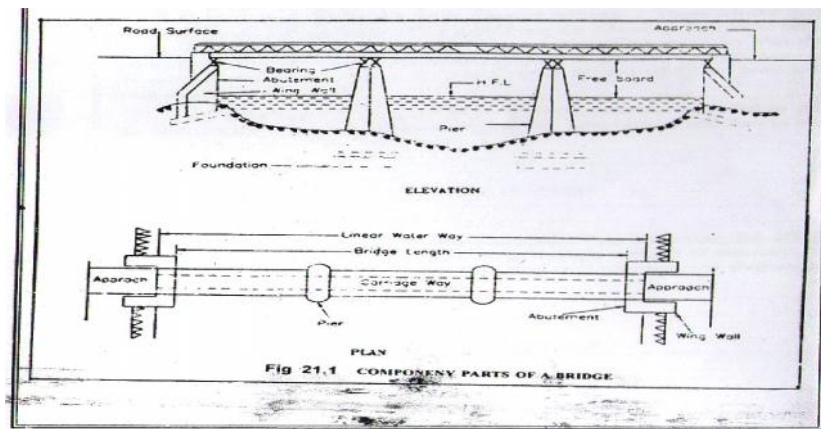

Its main functions are

1. To laterally support the earth work of the embankment of the approaches.
2. To transmit the load from the bridge superstructure.
3. To give final formation level to the bridge.

Bridge abutments can be made of brick masonry, stone masonry, plain concrete or reinforced concrete

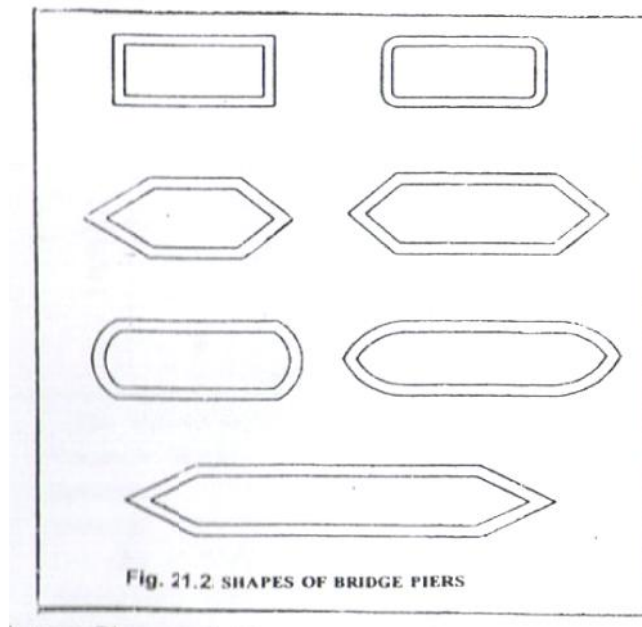

b. Piers : Piers are the intermediate supports for the superstructure. Piers transmit the loads from the superstructure of the bridge to the foundations. A pier essentially consists of a column or shaft and a foundation. They may have different configurations as shown in figure. These piers may be constructed with stone masonry or concrete.

c. Wing walls : These are the walls provided at both ends of the abutments to retain the earth filling of the approach road. They are constructed of the same material as those of the main abutment.

d. Approaches: The portion of the road constructed to reach the bridge from their general route or height is known as approach of the bridge. The alignment and the level of the approaches mainly depend on the design and layout of the bridge.

e. Foundations for the Piers and Abutments : The foundation of a bridge structure distributes the load from the piers and abutments over the larger area of sub soil. It prevents the tilting and over-turning of the piers and abutments and also unequal settlement of the sub soil.

The different types of functions adopted for bridges are:

- i. Spread foundation ii. Raft foundation iii. Pile foundation
- iv. Caisson foundation v. Well foundation

2. Super structure : The super structure is that part of the bridge over which the traffic moves with safely.

It consists of:

a. Decking b. Parapet or hand rails, guard stones etc. c. Bearing

a. Decking : It is provided to allow the road surface to be built in over it. It may consist of a slab, trusses, arches etc.

b. Parapet or Hand rails, guard stones: These are the protective works provided on both sides of the deck along the roadway in order to safe guard the moving vehicles and the passengers on a bridge. Foot paths are also provided for pedestrians to walk along the bridge. In order to prevent a vehicle from striking the parapet wall of the hand rails, guard stones painted white are provided at the ends of the road surfaces.

c. Bearing: It is part of the bearing structure provided to distribute the load coming from the superstructure and also to allow for longitudinal and angular movements.

3.6 DAMS

3.6.1 INTRODUCTION

A dam is an impervious barrier construction across a river to store water. The side on which water gets collected is called the upstream side, and the other side of the barrier is called the downstream side. The lake of water which is collected in the upstream side is called as reservoir. This water is then utilized as and when it is needed.

3.6.2 PURPOSE OF A DAM

1. To store and control the water for irrigation
2. To store and divert the water for domestic uses
3. To supply water for Industrial uses
4. To develop hydroelectric power plant to produce electricity
5. To increase water depths for navigation
6. To create storage space for flood control
7. To preserve and cultivate the useful aquatic life
8. For recreational purposes.

Multipurpose Reservoirs

A reservoir planned and constructed to serve not only one purpose but various purposes together is called a multipurpose reservoir.

Reservoir, designed for one purpose, incidentally serving other purposes, shall not be called a multipurpose reservoir.

Hence a reservoir designed to protect the down stream areas from floods and also to conserve water for water supply, irrigation, industrial needs, hydroelectric purposes etc. shall be called as MULTIPURPOSE RESERVOIR.

3.6.3 FACTORS GOVERNING SELECTION OF SITE FOR DAM

1. Suitable foundations should be available at the site selected for a particular type dam. For gravity dams, sound rock is essential. For earth dams, any type of foundations is suitable with proper treatment.
2. The river cross-section at the dam site should preferably have a narrow gorge to reduce the length of the dam. However, the gorge should open out u/s to provide large basin for a reservoir.
3. The general bed level at dam site should preferably be higher than that of the river basin. This will reduce the height of the dam and will facilitate the drainage.
4. A suitable site for the spillway should be available in the near vicinity. If the spillway is to be combined with the dam, the width of the George should be such as to accommodate both.
5. Materials required for the construction should be easily available, either locally or in the near vicinity, so that the cost of transporting them is as low as possible.
6. The reservoir basin should be reasonably water tight. The stored water should not escape out through its side walls and bed.
7. The value of land and property submerged by the proposed site should be as low as possible.
8. The dam site should be easily accessible so that it can be economically connected to important towns and cities by rails, roads, etc.
9. To establish site for labour colonies, a healthy environment should be available in the near vicinity.

3.6.4 CLASSIFICATION OF DAMS

Dams may be classified into different categories, depending upon the basis of the classification.

(a) Classification according to use : Based on use, dams are classified as follows :

- i. Storage dam ii. Diversion dam iii. Detention dam

i. Storage Dam : Storage dam is constructed to store water to its upstream side during the periods of excess supply in the river (i.e. during rainy season) and is used in periods of deficient supply.

ii. Diversion Dam : Diversion dam supply raises the water level slightly in the river and thus provides head for carrying or diverting water into ditches, canals or other conveyance systems to the place of use.

iii. Detention Dam : A detention dam is constructed to store water during floods and release it gradually at a safe rate when the flood reduces.

(b) Classification According to Hydraulic Design : According to hydraulic design, dams may be classified as follows :

i. Non – Overflow dam

ii. Overflow dam

i. Non-Overflow Dam :

A non-overflow dam is the one in which the top of the dam is kept at a higher elevation than the maximum expected high flood level.

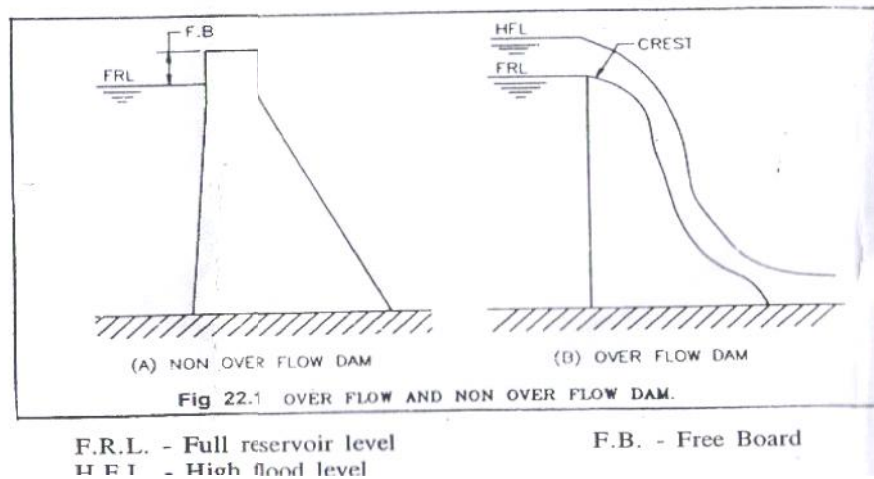
**ii. Over Flow Dam :**

An overflow dam is the one which is designed to carry surplus discharge (including floods) over its crest.

Usually, in a river valley project, the two types of dams are combined. The main dam is kept as a non – overflow dam and some portion of dam is kept as overflow dam (spill way) at some suitable location along the main dam.

c) Classification according to material : According to this classification, dam may be classification, dam may be classified as follows : i. Rigid dam ii. Non-rigid dam

i. Rigid Dams : Rigid dams are those which are constructed of rigid materials such as masonry, concrete, steel or timber. Rigid dams may be further classified as follows:

1. Solid Masonry gravity dam
2. Solid concrete gravity dam
3. Arched masonry dam
4. Arched concrete dam
5. Concrete buttress dam
6. Steel dam

7. Timber dam

ii. Non-Rigid Dams : Non-rigid dams are those which are constructed of non-rigid materials such as earth and or rockfill. The most common types of non-rigid dams are :

- 1. Earth dam
- 2. Rockfill dam

Gravity dams : A gravity dam is the one in which the external forces (such as water pressure, wave pressure, silt pressure, uplift pressure etc.) are resisted by the weight of the dam itself. A gravity dam may be constructed either of masonry or of concrete. Masonry gravity dams are now-a-days constructed of only small heights. All major and important gravity dams are now constructed of concrete only. A gravity dam may be either straight or curved in plan.

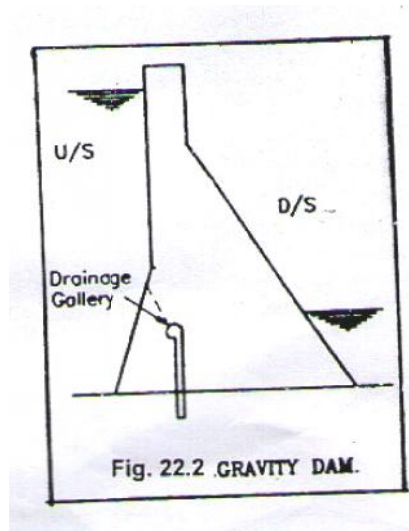

Arch dams : An arch dam is a dam curved in plan and carries a major part of its waterload horizontally to the abutments by arch action. The thrust developed by the water load carried by arch action essentially require strong side walls of the canyon to resist the arch forces. The weight of arch dams is not counted on to assist materially in the resistance of external loads.

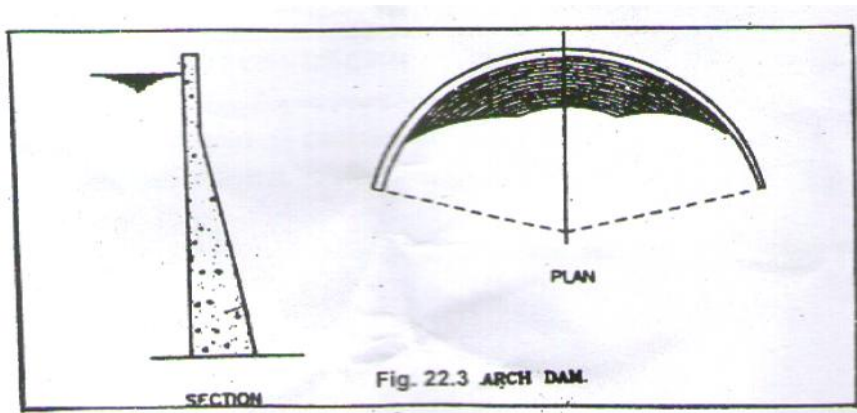

Butter Dams :

A buttress dam consists of a number of buttresses or piers. These piers divide the space (i.e. the space to be dammed) into number of spans. Between these piers, panels are constructed of horizontal arches or flat slabs. When the panels consist of arches, it is known as **Multiple arches type buttress dam**. If the panels consist of flat slab, it is known as **Deck type buttress dam**.

Steel Dams : Steel dams are constructed with a frame work of steel with a thin skin plate as deck slab, on the upstream side. Steel dams are generally of two types.

- i. Direct Strutted type
- ii. Cantilever type

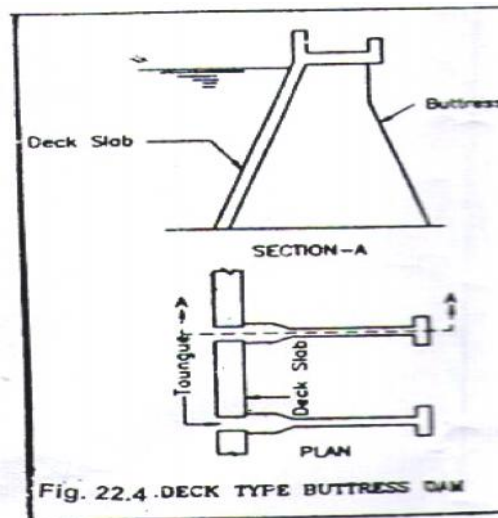

In the direct strutted type, the load on the deck plate is carried directly to the foundation through inclined struts. In the cantilever type, the deck is formed by a cantilever truss i.e. the deck is anchored to the foundation at the u/s toe.

Timber Dams : A timber dam is constructed of framework of timber struts and beams, with timber plan facing to resist water pressure. They are suitable in places where timber can be available in plenty.

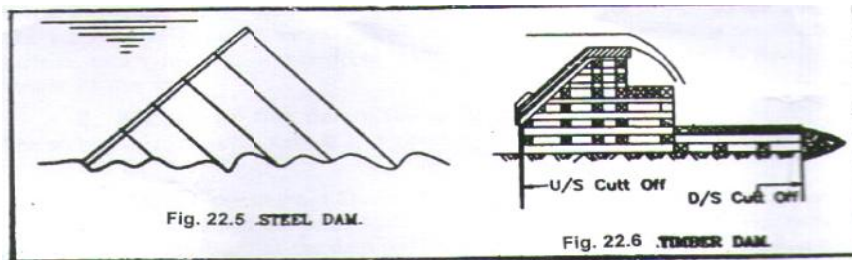

Earth Dams : Earth dams are made of locally available soils and gravels. Therefore, these type of dams are used upto moderate heights only. Their construction involves utilization of materials in the natural state requiring a minimum of processing.

Following are the three types of earth dams

- i. Homogeneous embankment type
- ii. Zoned embankment type
- iii. Diaphragm embankment type

i. Homogeneous embankment type : In this type, dam is composed of a single kind of material. But this dam is structurally weak. To check the seepage through the dam a horizontal filter drain or rock toe is provided.

ii. Zoned embankment type : In this type, the dam is made up of more than one material. Usually this dam consists of central impervious core and outer pervious shell as shown in figure. A suitable drainage system, in the form of horizontal drain or a rock toe is also provided.

iii. Diaphragm type embankment : In this type, a thin diaphragm of impermeable materials is provided at the centre of the section to check the seepage. The diaphragm may be made of cement masonry, cement concrete or impervious soils.

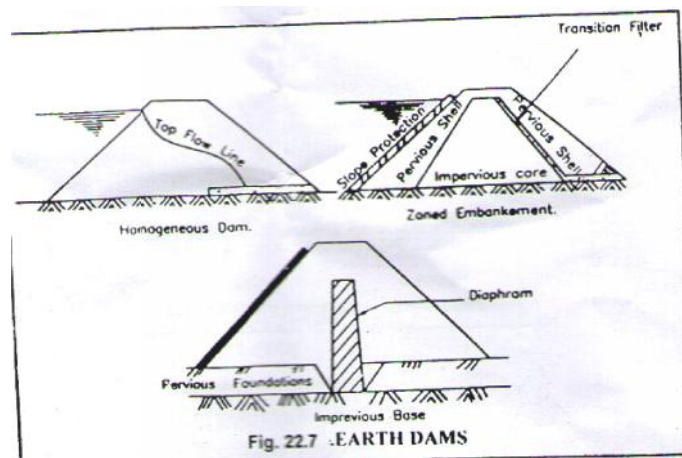

Rock fill dams : In this type, variable sizes of rocks are used to form the embankment. The rock fill dam usually consists of the following four parts.

- i. Main rock fill at the down – stream side
- ii. Up - stream rock – cushion of laid – up stone.
- iii. Up – stream impervious membrane resting on the upstream rock cushion.
- iv. Up stream cut-off to check the sub soil seepage

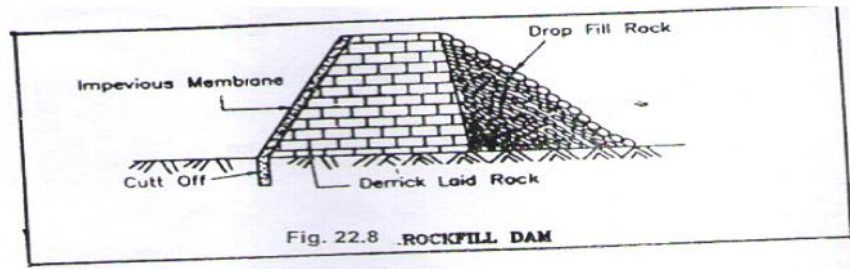

Basics of Interior Design and Landscaping

Interior design means successful renovation to make cosmetic improvements, not structural improvements, to house

An interior designer is a person who is considered a professional in the field of interior design or one who designs interiors as part of their job.

Interior designing is a practice concerned with anything that is found inside a space—walls, windows, door, finishes, and textures. Light etc. All of these elements are used by interior designers to develop a functional, safe, and aesthetically pleasing space for a building's user.

They plan the spaces of almost every type of building including hotels, corporate spaces, schools, hospitals, private residence, shopping malls etc. Today, interior designers must be attuned to architectural detailing including: floor plans, home renovations, and construction codes.

3.7 Basics of interior design

Guidelines:

A successful room is functional

A successful room expresses a mood

A successful room exhibits a sense of harmony

Function

A room must serve its intended function. No matter how beautifully you decorate a room, if your scheme can't fulfill all the functions you require the room to perform, then the room has failed. If a dining room is not convenient to eat in, then Fails.

Mood

Mood refers to the general look or feeling you want the room to express. The colour schemes, furniture, window treatments, floor treatments and lighting styles etc.

Harmony

All the separate elements in a room must work together in harmony. All elements should feel appropriate and nothing should feel out of place. Every element should be harmonious in mood, scale, quality and color. The scale must also be harmonious, this means all elements should be the same scale as each other and the same scale of the room itself. No huge chairs with small chairs etc. The quality also needs to be harmonious. If you are using expensive high quality furniture then don't use them with cheap looking curtains etc. And lastly the color schemes must be harmonious. The color schemes in your furniture must not clash with the color schemes in your rug etc.

Steps for designing room

- ✓ Sketching a room
- ✓ Drawing a floor plan
- ✓ Furniture layout
- ✓ Lighting plan.

Landscaping

Landscaping refers to any activity that modifies the visible features of an area of land, including but not limited to:

Living elements such as flora or what is commonly referred to as Gardening, the art and Craft of growing plants with a goal of creating a beautiful environment within the landscape

Natural elements such as landforms, terrain shape and elevation

Human elements such as structures, buildings, fences or other material objects created and installed by humans

Abstract elements such as the weather and lighting conditions.

Landscaping is both science and art, and requires good observation and design skills. A good landscaper understands the elements of nature and construction and blends them accordingly

Landscape design

Landscape design is similar to landscape architecture. Landscape design focuses more on the artistic merits of design, while landscape Architecture encompasses the artistic design as well as structural engineering.

Traditionally, landscape designers and architects have used pencil and paper to plot the position of plants and other landscape features.

Basic element of landscaping

- ✓ Unity
- ✓ Simplicity
- ✓ Balance
- ✓ Focalization

BASIC MECHANICAL ENGINEERING

Unit 3

(Power Plant Engineering, Pumps and Turbines)

3.1 CLASSIFICATION OF POWER PLANTS

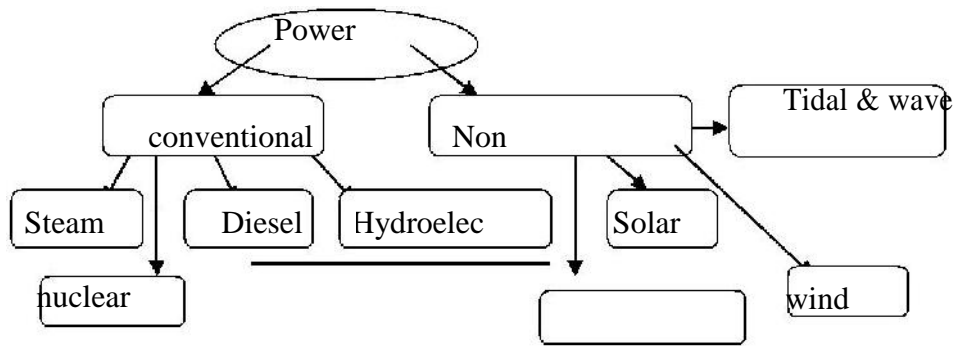

reasons:

1. Steam can be raised quickly from water
2. It does not react much with materials.
3. It is stable at temperatures required in the plant

3.2 LAYOUT OF STEAM POWER PLANT:

The layout of steam power plant has the following circuits:

1. Fuel (Coal) and ash circuit
2. Air and flue gas circuit
3. Feed water and steam flow circuit
4. Cooling water flow circuit.

3.2.1 COAL AND ASH CIRCUIT:

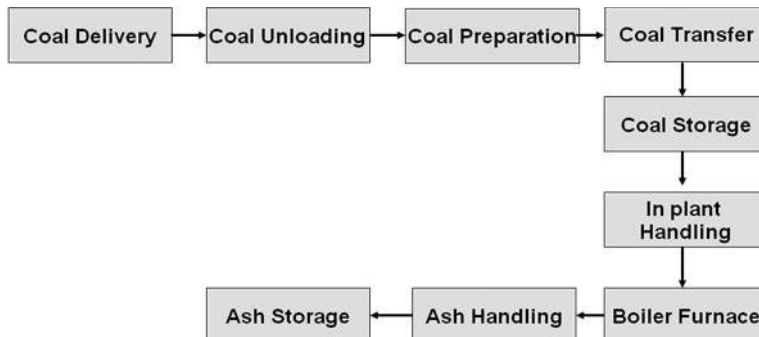

Layout of Steam power Plant

Coal and Ash Circuit:

- Coal from mines is delivered by ships, rails or trucks to the power station.
- Coal received at coal yard.
-
- Coal is sized by crushers, breakers etc.,
- The sized coal is stored in coal storage.
- From stock yard, the coal is transferred to the boiler furnace by means of conveyors, elevators etc.,
- The coal is burnt in the boiler and ash is formed.
- Ash coming out of the furnace will be too hot, dusty and accompanied by poisonous gases.
- The ash is transferred to the ash storage.
- Generally the ash will be quenched to reduce the temperature and the dust content.

3.2.2 AIR AND FLUE GAS CIRCUIT:

- Air is taken from the atmosphere by the action of FD fan.
- It is passed through an air pre heater
- The air is preheated by the flue gases in the pre heater.
- This preheated air is supplied to the furnace to aid the combustion of fuel.
- Due to the combustion of fuel the flue gases are formed.
- The flue gases from the furnace pass over the boiler tubes and super heater tubes.
- Then the flue gases pass through economiser to heat the feed water.
- After that it passes through a dust collector.

It is then exhausted to atmosphere through chimney

3.2.3 WATER AND STEAM CIRCUIT

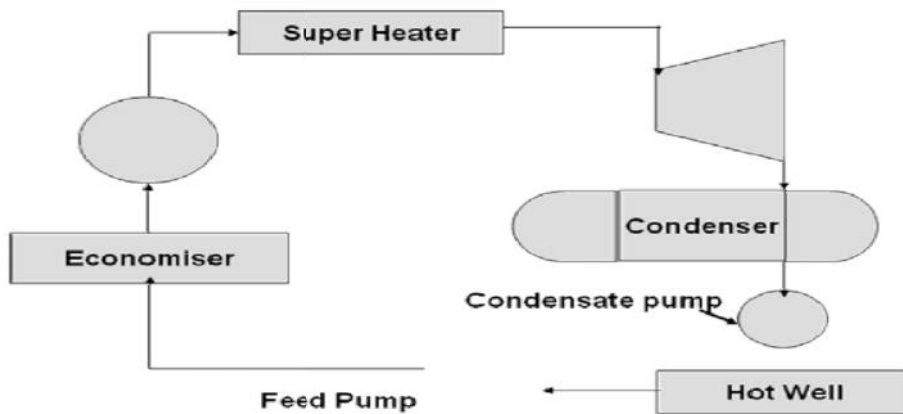

Layout of Steam Power Plant

Water and Steam Circuit:

- The water is preheated by the flue gases in the economiser.
- This preheated water is then supplied to the boiler drum.
- Heat is transferred to the water by the burning of the coal.
- Due to this, water is converted into the steam.
- The steam raised in boiler is passed through a super heater.
- It is superheated by the flue gases.
- The turbine drives generator to produce electric power.
- The expanded steam is then passed through the condenser.
- In the condenser, steam is condensed into water there circulated.

3.2.4 COOLING WATER CIRCUIT:

- The exhaust steam from the turbine is condensed in the condenser.
- In the condenser, the cold water is circulated to condense the steam into water.
- The steam is condensed by losing its latent heat to the circulating the cold water.
- Hence the cold water gets heated.
- This hot water is then taken to a cooling tower.
- In cooling tower the water is sprayed in the form of droplets through nozzles.
- The atmospheric air enters the cooling tower from the openings provided at the bottom of the tower.

- This cold water is again circulated through the pump, condenser and the cooling
- Some amount of water may be lost during circulation.
- Hence make up water is added to the pond by means of a pump

Layout of Steam (Thermal) Power Plant

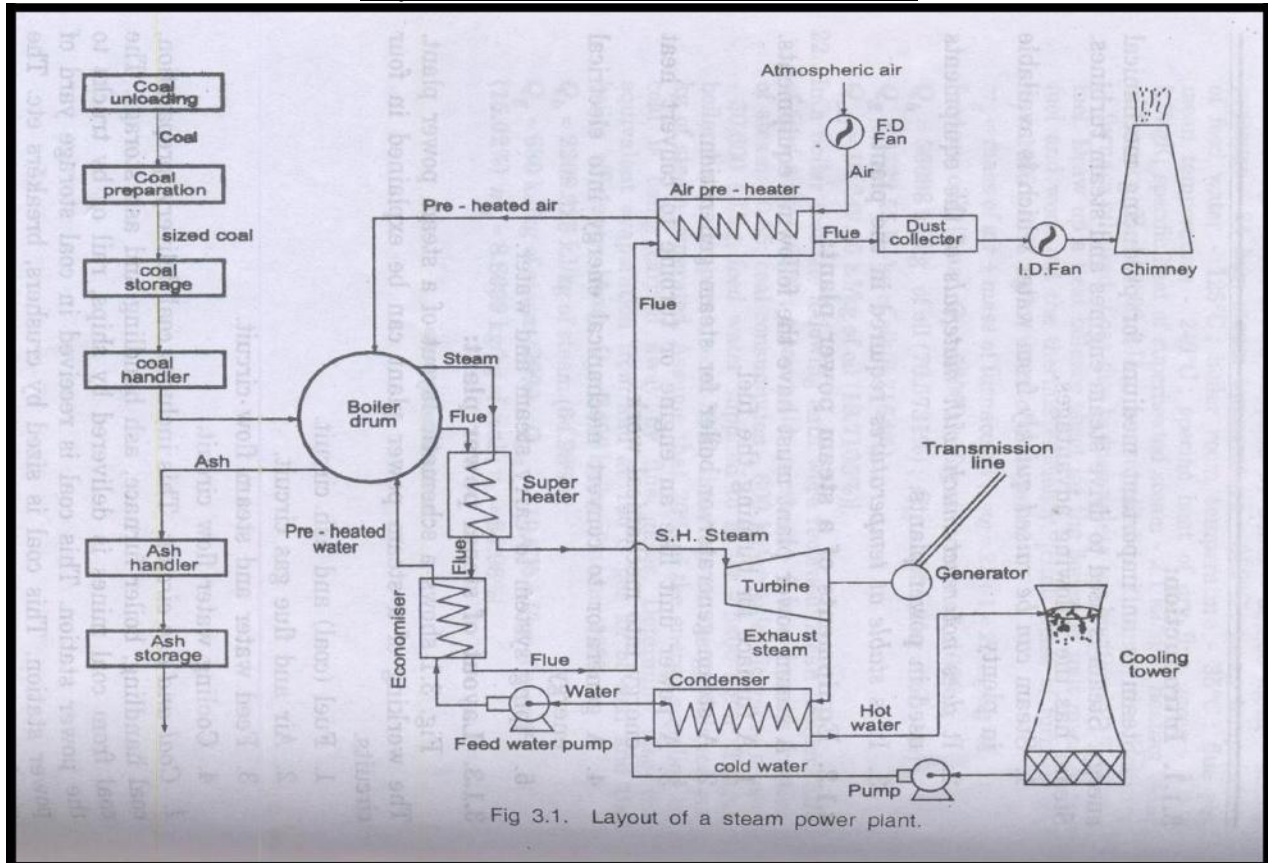

Energy Conversion Process:

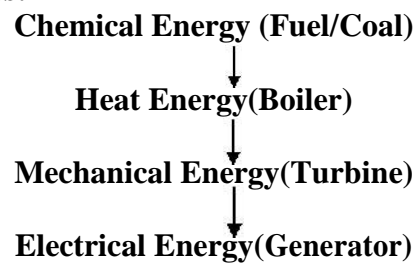

Advantages of Steam Power Plant (Thermal plant)

- Life of plant is more (25-30 years) compared to Diesel plant (2-5 years)
- Repair and maintenance cost is low when compared to diesel plant.
Initial cost is less compared to nuclear plant.

- Suitable for varying load conditions.
- No radioactive harmful wastes are produced
- Unskilled operators can operate the plant.
- The power generation does not depend on the water storage.
- There are no transmission losses, as they are located near load centres.

Disadvantages of thermal power plant:

- Less efficient than diesel plants.
- Starting up and bringing into service takes more time.
- Cooling water required is more.
- Space required is more.
- Storage required for the fuel is more.
- Ash handling is a big problem
- Not economical in areas which are remote from coal fields.
- Manpower required is more.
- For large units, the capital cost is more.

3.3 LIST DOWN THE FACTORS TO BE CONSIDERED FOR SELECTION OF SITE FOR THERMAL POWER PLANT:**Availability of coal:**

- A thermal plant of 400M, capacity requires nearly 6000 tons of coal every day.
- Power plant should be located near coal mines.

Ash Disposal Facilities:

- Ash comes out in hot condition and handling is difficult.

The ash can be disposed into sea or river.

Water Availability :

- Water consumption is more as feed water into boiler, condenser and for ash disposal.
- Water is required for drinking purpose.
- Hence plant should be located near water source.

Transport Facility :**Public Problems:**

- The plant should be far away from residential area to avoid nuisance from smoke, fly ash and noise.

Nature of Land :

- Many power plants have failed due to weak foundations.
- Land (soil) should have good bearing capacity to withstand dead load of plant.

Thermal power plants in T.N:

Neyveli
Tuticorin
Ennore
Mettur

Explain about the pollution caused by Thermal Power Plant (Steam Power Plant):

- Main pollutants from thermal plants are SO_2 , CO_2 , CO as minute particles such as fly ash.
- SO_2 causes suffocation, irritation to throat and eyes and respiratory for people. It destroys crop.
- CO is a poisonous gas.
- Dust particles cause respiratory troubles like cough, cold, sneezing etc.,

Thermal Pollution:

- Thermal plants produce 40 million kJ of heat to the environment through condenser water and exhaust gases.
- Thermal pollution of atmosphere can be reduced using the low grade energy exhausted steam.

Noise Pollution:

- The sources of noise in a power plant are turbo alternators, fans and power transformers.
- Sound proofing can be done to reduce the noise.

3.4 GAS POWER PLANT

- A gas power plant uses gas turbine as the prime mover for generating electricity.
- It uses natural gas or kerosene or benzene as fuel.
- Gas plant can produce only limited amount of the electricity.
- Efficiency of the plant is only 35%
- Generally a gas plant is expensive to operate.

- Hence it is usually installed with steam power plant in closed combined cycle.
- It is generally used in combination with steam/thermal power plant during peak load
- When the gas power plant is combined with thermal/steam power plant efficiency of the plant is up to 60% - 70%

Layout of the Gas turbine Power plant:

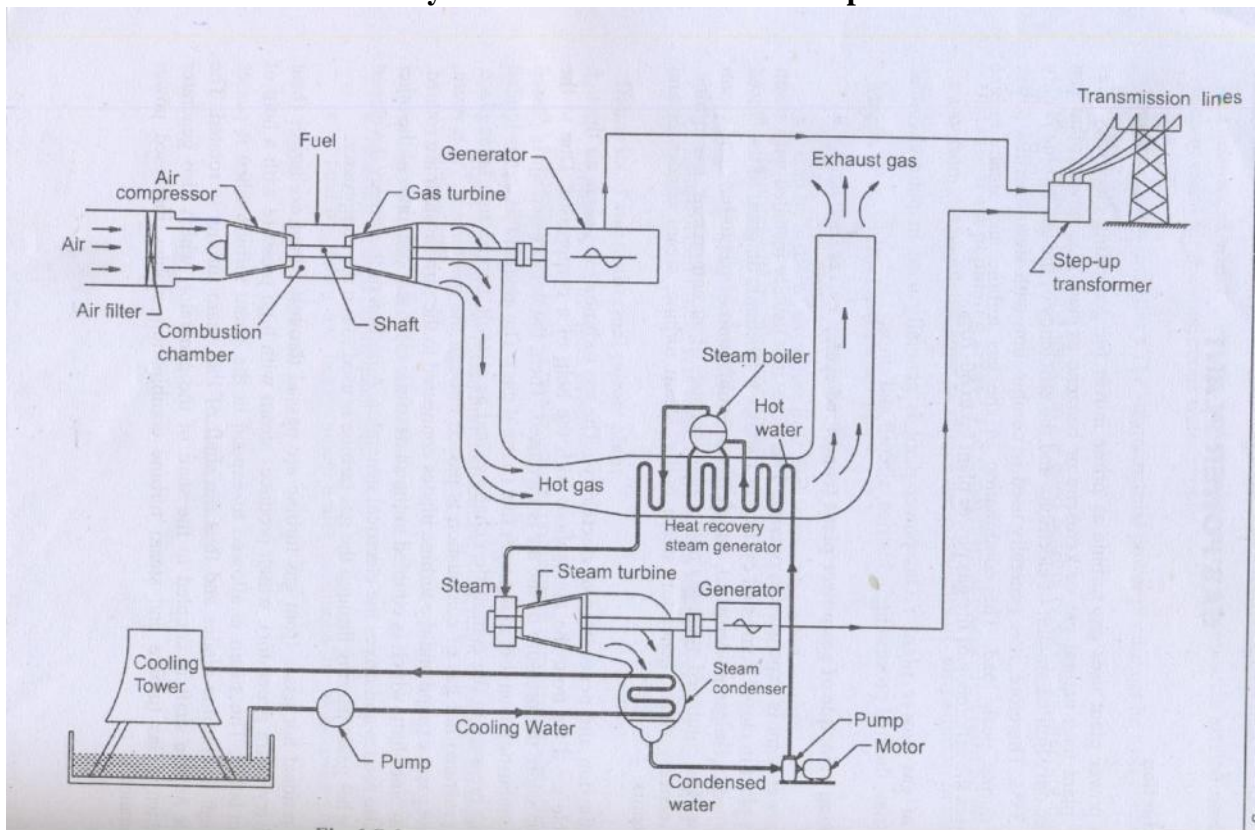

Combustion and generation of electricity:

- Gas turbine draws clean air into through air filter from atmosphere, with the help of a compressor.
- During the compression pressure of the air is increased.
- Compressed air is passed through to a combustion chamber along with fuel (Natural gas).
- The air fuel mixture is ignited at high pressure in the combustion chamber.

- Combustion takes place.
- The generated hot gas of compression is passed through the gas turbine.
- Hot gases expand, and the turbine blades are connected to the turbine shaft are rotated.
- The turbine shaft which is coupled to the shaft of the electrical generator at the other end also rotates and drives the electrical generator.
- A portion of the energy developed by the hot gases through the gas turbine is used to run the compressor.
- The residual hot gases from gas turbine are passed through a heat exchanger (heat recovery steam generator)
- The heat exchanger produces steam with high pressure with the help of a steam boiler.
- The steam is allowed to expand in the steam turbine.
- when it passes through the turbine blades, the turbine shaft is rotated. The shaft is coupled to the generator, which generates electricity.
- Gas turbine and steam turbine combination enables increased power generation.

Transmission and distribution :

- The generated electricity from both gas and steam turbines is fed to the step up transformer where its voltage is increased.
- Then the electricity is conveyed through transmission lines for distribution.

MERITS:

- Natural gas is readily available.
- Setting up cost can be reduced if the plant is installed near the source of natural gas.
- Less gas storage cost
- Less space occupation.
- Compared to steam power plant, smaller in size.
- Low operating cost.
- Low maintenance cost.
- No standby losses.
- Cheaper fuels like natural gas.

Demerits:

- Gas turbine has low thermal efficiency.
- Has starting problem.
- Efficient only in combined cycle configuration.
- Temperature of combustion chamber is too high, which results in shorter life time.

3.5 DIESEL POWER PLANT

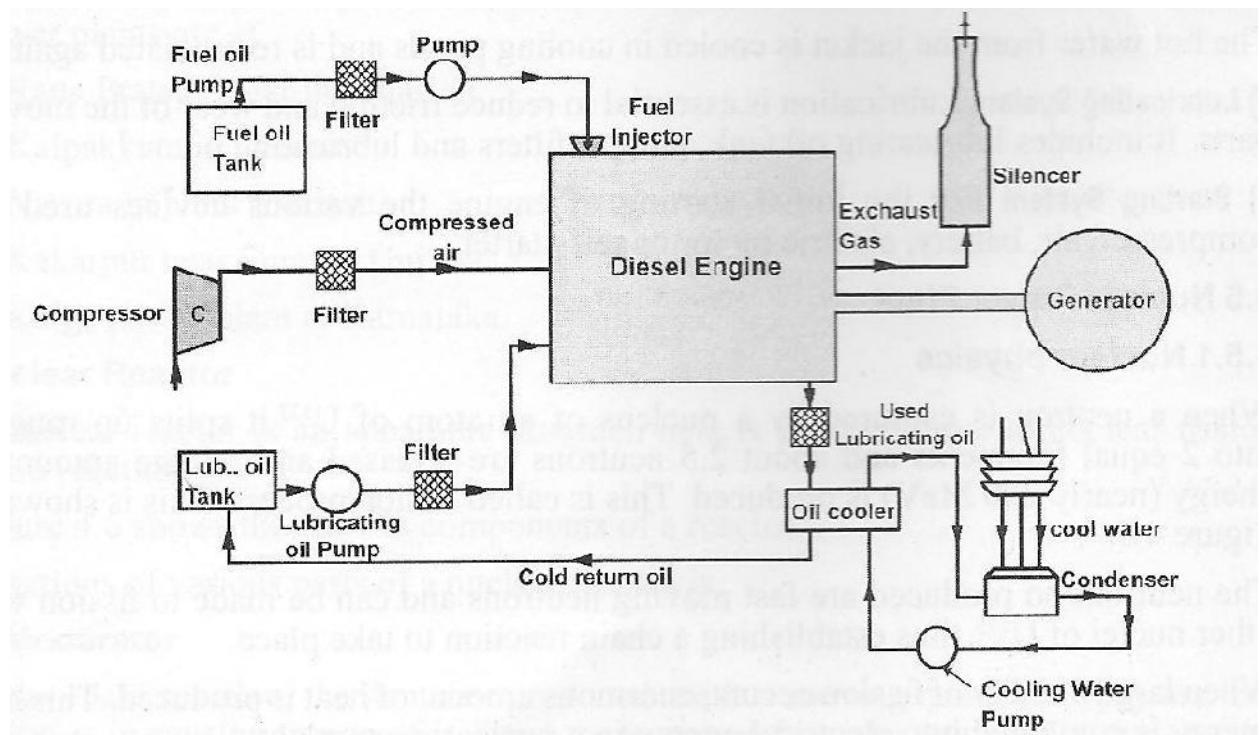

3.5.1 WORKING OF DIESEL POWER PLANT:

- Air from atmosphere is drawn into the compressor and is compressed.
- The compressed air is sent to diesel engine through filter.
- In the filter, dust, dirt from air are filtered and only clean air is sent to diesel engine.
- Fuel oil from tank is passed through filter where it gets filtered and clean oil is injected into the diesel engine through fuel pump and fuel injector
- Mixture of compressed air and spray of fuel oil are ignited into the engine and combustion takes place.
- The heat energy is utilized for driving the generator, which produces power.

3.5.2 MAIN COMPONENTS OF A DIESEL POWER PLANT:

1. Fuel Supply system

It consists of fuel tank, fuel filter and fuel pump and injector.

2. Air Intake and Exhaust system

It consists of compressor, filter and pipes for the supply of air and pipes for exhaust gases. In the exhaust system silencer is provided to reduce the noise.

3. Cooling system

Circulates water around the Diesel engines to keep the temp at reasonably low level.

4. Lubricating system

It includes lubricating oil tank, pump, filters and lubricating oil.

5. Starting system

For initial starting the devices used are compressed air, battery, electric motor or self-starter.

3.6 HYDRO ELECTRIC POWER PLANT:

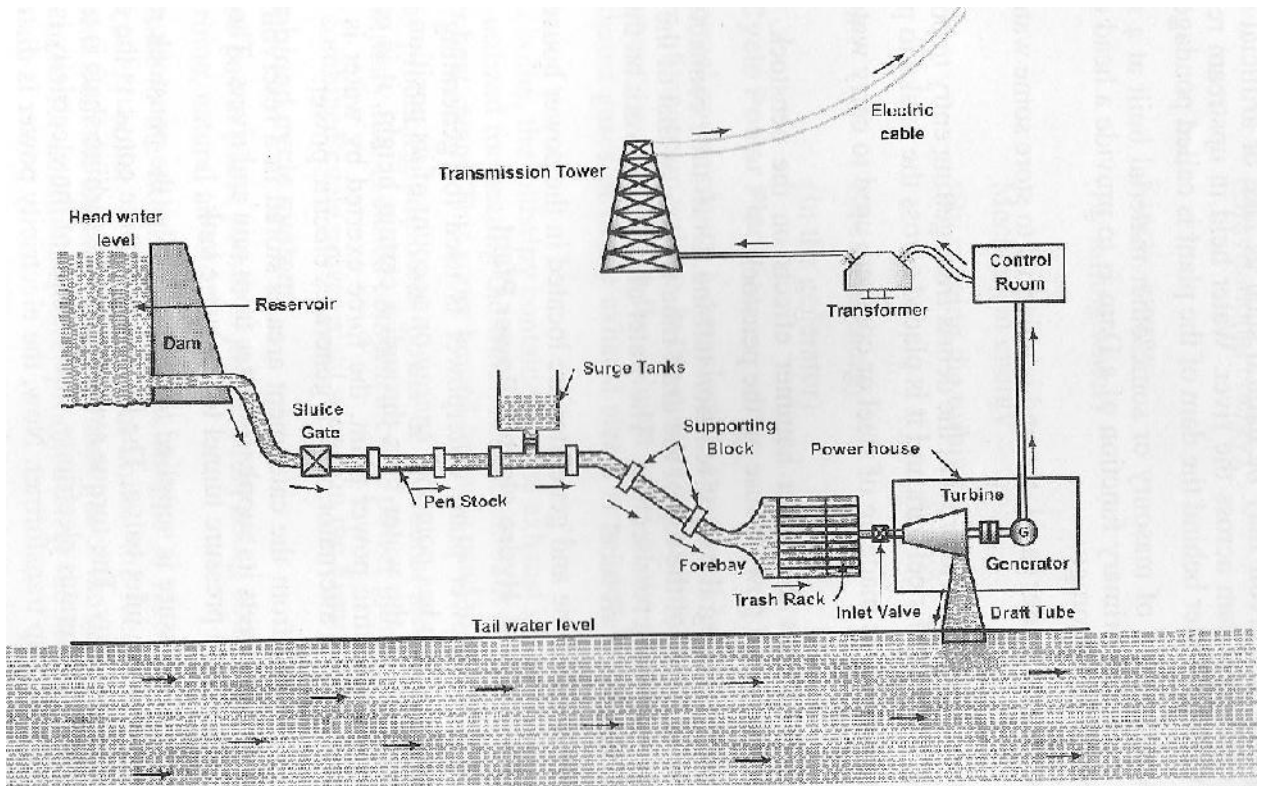

3.6.1 COMPONENTS OF HYDRO ELECTRIC POWER PLANT:

Reservoir :

- Water is collected during rainy season

- It is stored in the reservoir.
- A dam is built across the river adequate water head.

Penstock :

- It is a passage through which water flows from reservoir to turbine.

Surge Tank :

- It is installed along the penstock (between turbine and reservoir)
- To control or regulate the sudden water over flow and to protect the penstock from bursting.
- It reduces the pressure and avoids damage to the penstock due to the **water hammer** effect.
- When the load on the turbine is decreased there will be a back flow, which causes increase or decrease in pressure. It is known as water hammer.
- Power House :
- It is building that houses that water turbine, generator, transformer and control room.
- Water Turbine:
- Water turbines such as Pelton, Kaplan and Francis are used to convert pressure and kinetic energy of flowing water into mechanical energy.
- Draft Tube:
- It is connected to the outlet of the turbine.
- Tailrace:
- It refers to the downstream level of water discharged from turbine.
- Generator :
- It is a machine used to convert mechanical energy into electrical energy.
- Step up transformer:
- It converts the Alternating Current (AC) into high voltage current suitable for transmission.

3.6.2 WORKING PRINCIPLE OF HYDRO ELECTRIC POWER PLANT:

- It uses the potential energy of water of water stored in a reservoir.
- The water from the reservoir through a penstock and then forced through nozzle or nozzles before reaching the turbine.
- The hydraulic turbine converts the kinetic energy of water under pressure into mechanical energy.
- The shaft of the turbine is coupled to a generator that generates electricity
- The electricity generated is fed to the step-up transformer to increase its voltage.
- Power is fed to the transmission lines for distribution.
- The output power of Hydel power plant depends on the head of water stored in the reservoir and the quantity of water discharged

3.6.3 CLASSIFICATION OF HYDRO ELECTRIC POWER PLANT:

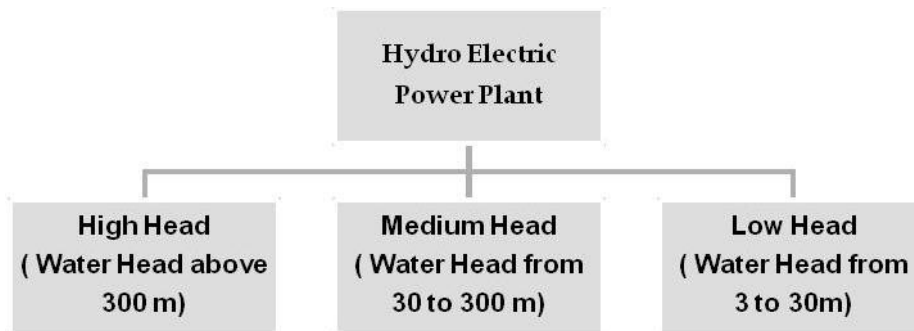

Factors to be considered for the location of hydro electric Power

Availability of Water:

Adequate water must be available with good head.

Cost and type of Land:

Bearing capacity of the land should be good to withstand huge structures and equipments.

Storage of Water :

A dam must be constructed to store the large quantity of water in order to cope with variations of water availability through out the year.

Transportation Facilities :

The site should be accessible by rail and road for easy transportation of equipments and machinery.

Pumped storage facilities :

The pumping facilities to reuse the water should be possible.

Merits of Hydro Electric Power Plant:

- Requires no fuels and hence pollution free.
- Low operating cost.
- Simple in construction and requires less maintenance.

- Skilled personnel is required for construction.
- High cost of transmission as plant is normally required far off from hilly areas.
- Period of delay causes the delay in the commissioning of the plant.
- Construction of new hydel plant may need rehabilitation of people and payment compensation for land acquisition.

3.7 NUCLEAR POWER PLANT

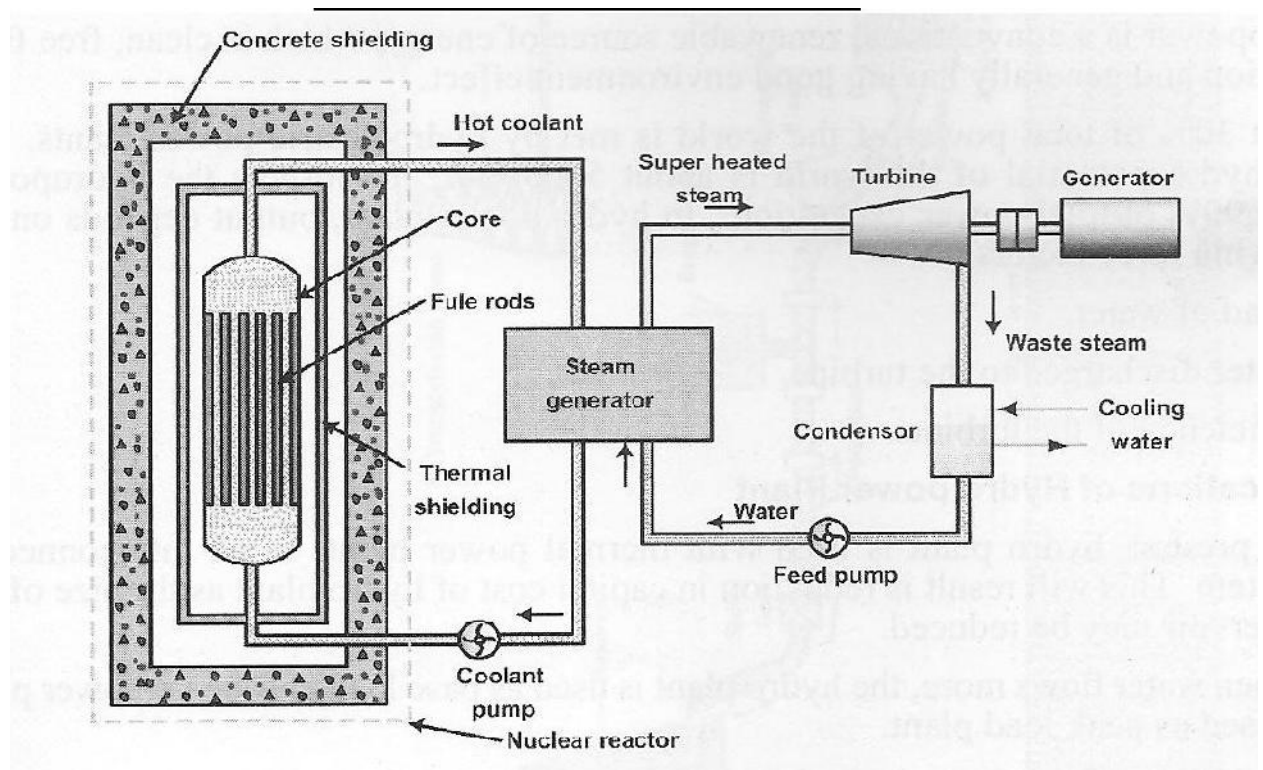

Nuclear Power plant layout

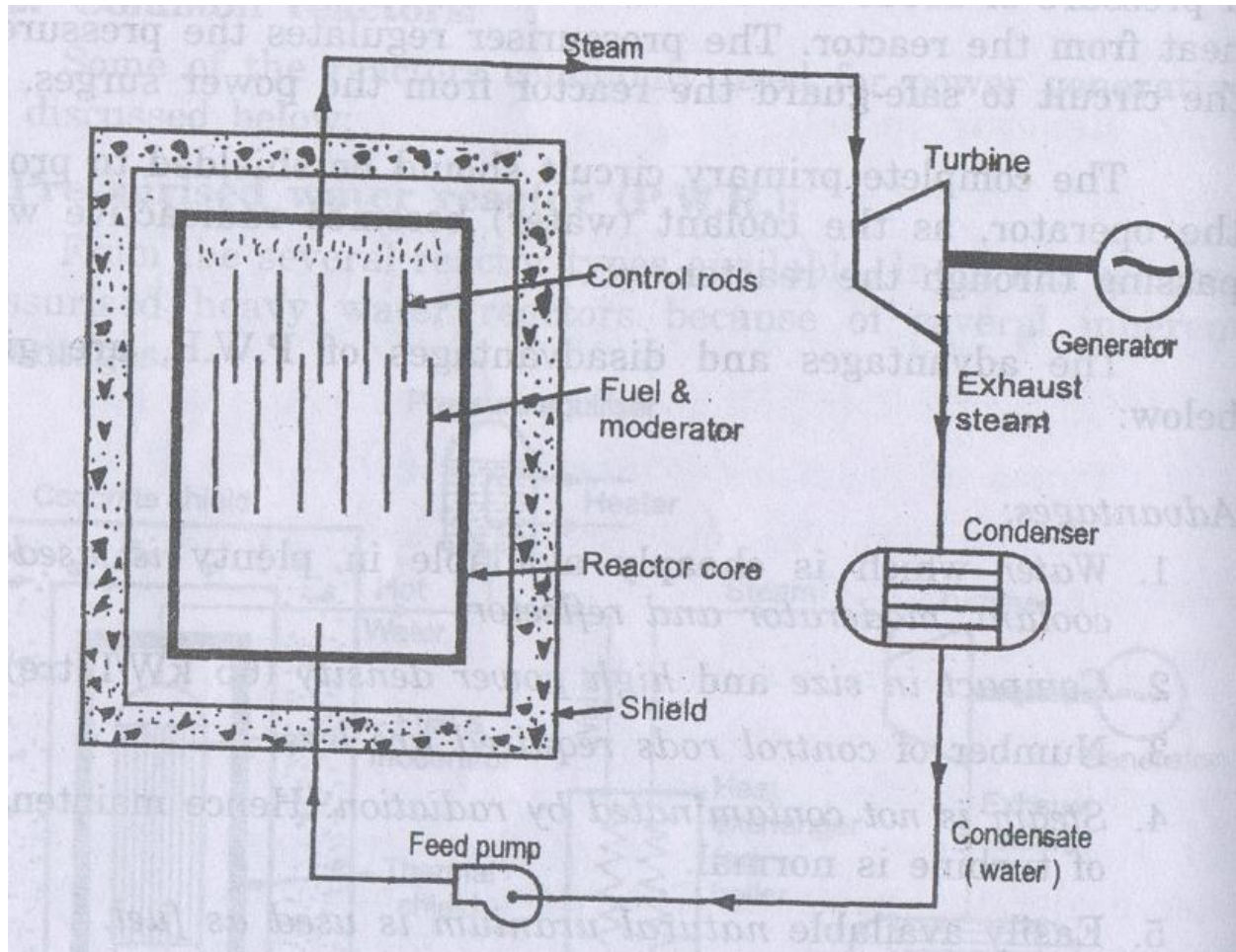

- Nuclear power plant uses nuclear energy from radioactive element for generating electrical energy.
- More than 15% of the world's electricity is
- It is generally located far away from populated areas.
- In future generation of electricity will be depending on Nuclear Power Plant, as it is economical.
- 1 kg of uranium U -235 can produce electrical power electrical that can be produced by using 3000 -4500 tonnes of high grade coal or 2000 tonnes of oil.

3.7.1 COMPONENTS OF NUCLEAR POWER PLANT:

Nuclear Fuel :

Normally used nuclear fuel is uranium (U^{235})

Fuel Rods:

The fuel rods hold nuclear fuel in a nuclear power plant.

Neutron Source: A source of neutron is required to initiate the fission for the first time. A mixture of beryllium with plutonium is commonly used as a source of neutron.

Reactor:

- Nuclear fission takes place in the reactor only.
- Nuclear fission produces large quantity of heat.
- The heat generated in the reactor is carried by coolant circulated through the reactor.

Control Rods:

- They are used to control the chain reaction.
- They are absorbers of neutrons.
- The commonly used control rods are made up of cadmium or boron.

Moderator:

- Moderators are used to slow down the fast neutrons.
- It reduces 2 MeV to an average velocity of 0.025 eV.
- Ordinary or heavy water are used as moderators.

Fuel Rods:

- The fuel rods hold nuclear fuel in a nuclear power plant.

Neutron Reflectors:

- To prevent the leakage of neutrons to large extent.
- In PHWR, the moderator itself acts as reflectors.

Shielding:

- To protect from harmful radiations the reactor is surrounded by a concrete wall of thickness about 2 to 2.5 m.

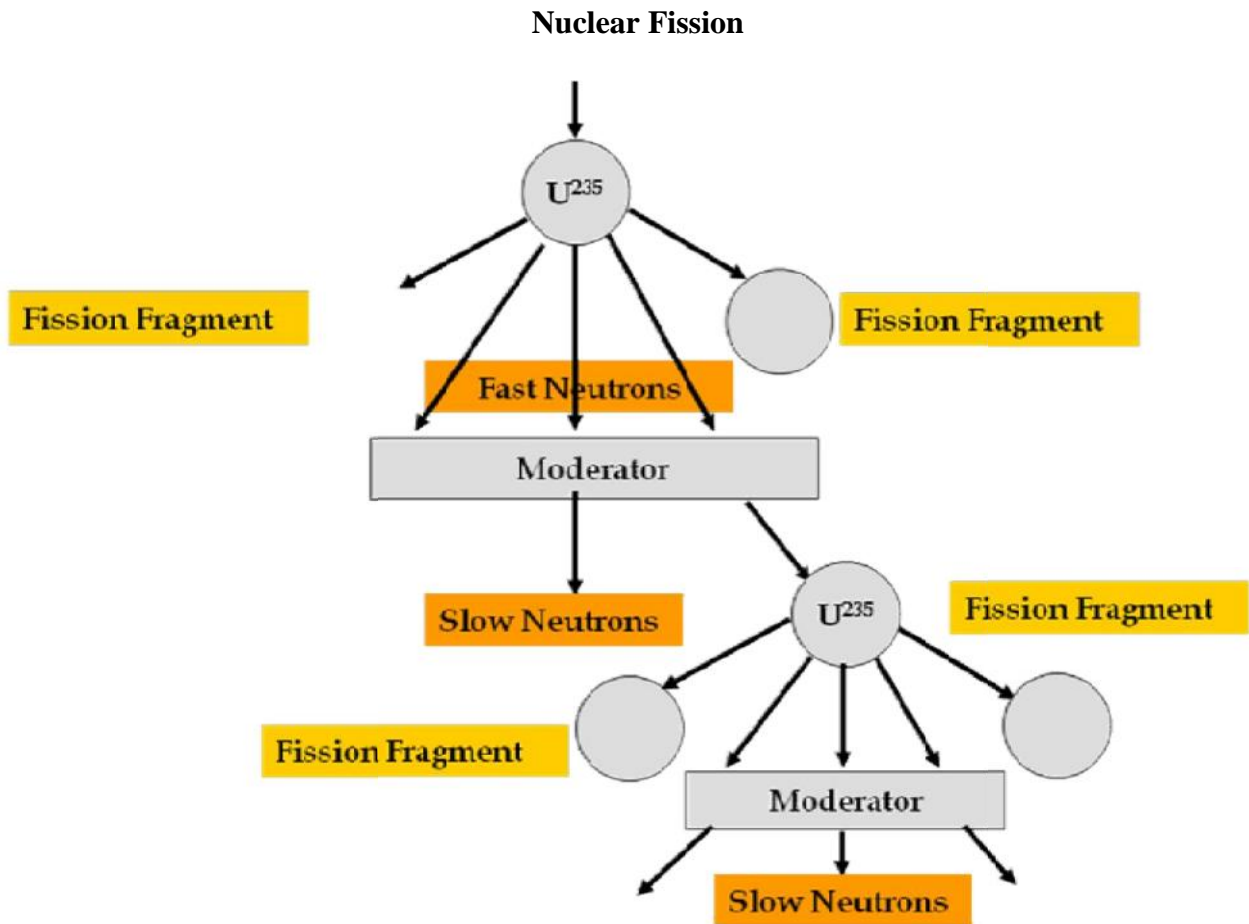

- It is a process of splitting up of nucleus of fissionable material like uranium into two or more fragments with release of enormous amount of energy.
- The nucleus of U^{235} is bombarded with high energy neutrons
- The neutrons produced are very fast and can be made to fission other nuclei of U^{235} , thus setting up a chain reaction.
- Out of 2.5 neutrons released one neutron is used to sustain the chain reaction.

$$1 \text{ eV} = 1.6 \times 10^{-19} \text{ joule.}$$

$$1 \text{ MeV} = 10^6 \text{ eV}$$

3.7.2 WORKING PRINCIPLE OF NUCLEAR POWER PLANT:

- The heat generated in the reactor due to the fission of the fuel is taken up by the coolant.
- The hot coolant then leaves the reactor and flows through the steam generator.
- In the steam generator the hot coolant transfers its heat to the feed water which gets converted into steam.
- The steam produced is passed through the turbine, which is coupled with generator.

- Hence the power is produced during the running of turbine.
- The exhaust steam from the turbine is condensed in the condenser.
- The condensate then flows to the steam generator through the feed pump.
- The cycle is thus repeated.

Advantages of Nuclear Power Plant:

- Requires less space compared to steam power plant.
- Fuel required is negligible compared to coal requirement.
- Fuel transport cost is less.
- Reliable in operation.
- Cost of erection is less.
- Water required is very less.

Disadvantages of Nuclear Power Plant:

- Initial Cost is higher.
- Not suitable for varying load condition.
- Radioactive wastes are hazardous. Hence these are to be handled with much care.
- Maintenance cost is higher.
- Trained workers are required to operate the plant.

Nuclear Power Plants in India:

- IGCAR, Kalpakkam in Chennai.
- Rana Pratap Sagar in Rajasthan
- Narora in Uttar Pradesh
- Kakrapur near Surat at Gujarat

3.8 PUMPS

- A pump is a machine which is used to raise or transfer the fluids.
- It is also used to maintain the constant flow rate or constant pressure.
- It is normally driven by a engine or a motor.
- Pumps are rated by the horse power.

3.8.1 CLASSIFICATION OF PUMPS:

It is classified into positive displacement pumps and roto dynamic pumps.

- In **positive displacement pumps**, fluid is drawn or forced into a finite space and it is sealed.
- It is then forced out and the cycle is repeated.

In **roto dynamic pumps**, centrifugal force is used to move the fluid into a pipe.

3.8.2 RECIPROCATING PUMPS:

- It is a positive displacement pump
- It uses a piston and cylinder arrangement with suction and delivery valves integrated with the pump.
- It can be single acting and double acting
- There may be single or multi cylinders also.
- It is a positive displacement pump
- It sucks and raises the liquid by actually displacing it with a piston/plunger that executes a reciprocating motion in a closely fitting cylinder.

3.8.3 WORKING OF SINGLE ACTING RECIPROCATING PUMP:

- During suction stroke the piston moves to the left, causing the inlet valve to open.
- Water is admitted into the cylinder through the inlet valve.
- During the discharge stroke the piston moves to the right closes the suction valve and opens the out let valve.
- Through the outlet valve the volume of liquid moved out of the cylinder.

3.8.4 DOUBLE ACTING RECIPROCATING PUMP –WORKING:

- Each cycle consists of two strokes.
- Both the strokes are effective, hence it is known as double acting pump
- Liquid is filled at one end and discharged at other end during forward stroke.
- During the return stroke, end of cylinder just emptied is filled and the end just filled is emptied.

3.9 AIR VESSELS

Air vessel is a closed chamber containing compressed air in the upper part and liquid being pumped in the lower part.

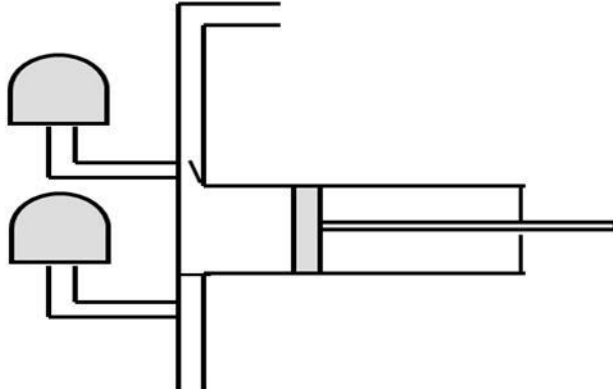

3.9.1 PURPOSE OF USING AN AIR VESSEL:

- To get continuous supply of liquid at a uniform rate.
- To save the power required to drive the pump (By using an air vessel the acceleration and friction heads are considerably reduced)
- To run the pump at much higher speed without any danger of separation.

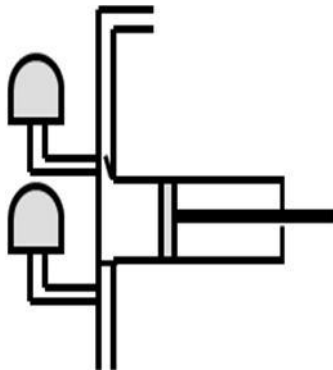

Advantages of reciprocating pump:

- Relatively compact design
- High viscosity performance
- Ability to handle high differential pressure.

3.10 CENTRIFUGAL PUMPS

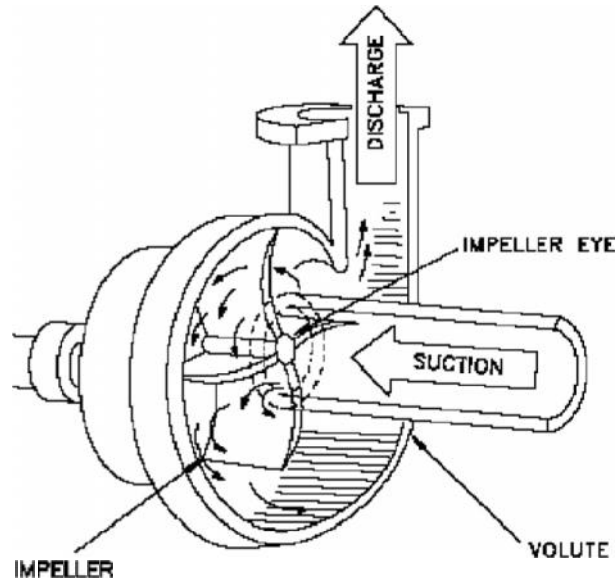

3.10.1 COMPONENTS OF CENTRIFUGAL PUMP:

- A rotating component comprising of an impeller and a shaft.
- A stationery component comprising a volute (casing), suction and delivery pipe.

3.10.2 WORKING PRINCIPLE OF CENTRIFUGAL PUMP:

Principle:

When a certain mass of fluid is rotated by an external source, it is thrown away from the central axis of rotation and a centrifugal head is impressed which enables it to rise to a higher level.

Working:

- The delivery valve is closed and the pump is primed, so that no air pocket is left.
- Keeping the delivery valve still closed the electric motor is started to rotate the impeller.
- The rotation of the impeller is gradually increased till the impeller rotates at its normal speed.
- After the impeller attains the normal speed the delivery valve is opened when the liquid is sucked continuously upto the suction pipe.
- It passes through the eye of the casing and enters the impeller at its centre.
- The liquid is impelled out by the rotating vanes and it comes out at the outlet tips of the vanes into the casing.

- Due to the impeller action the pressure head as well as the velocity heads are increased.
- From the casing the liquid passes into the pipe and lifted to the required height.
- When pump is to be stopped the delivery valve is to be first closed, otherwise there may be some backflow of water into the reservoir.

**Types of casing
Volute and Vortex Casing**

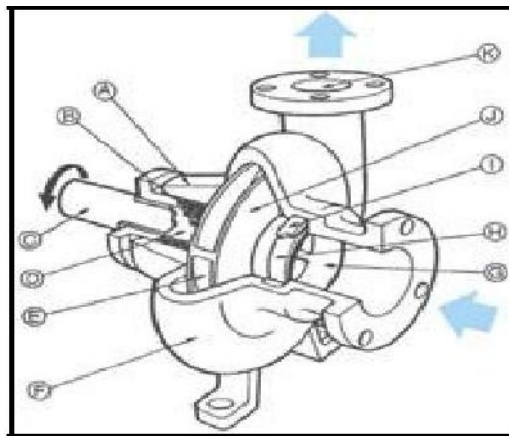
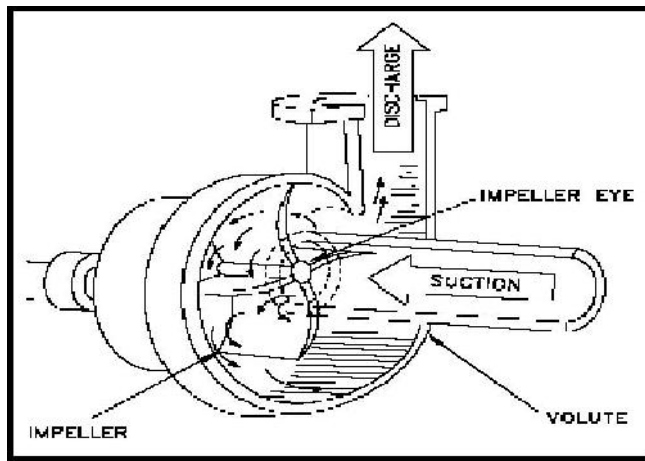

Volute and Diffuser casing

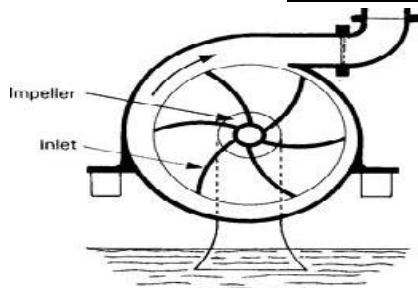

A. - Volute Centrifugal Pump.

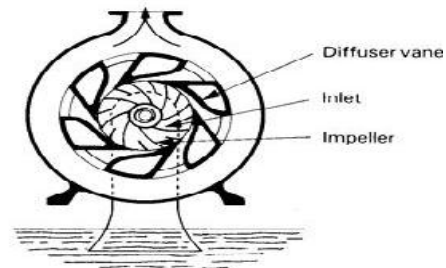

B. - Turbine Centrifugal Pump.

Volute Casing: In this type of casing the area of flow gradually increases from the impeller outlet to the delivery pipe.

Vortex Casing:

If a circular chamber is provided between the impeller and volute chamber the casing is known as Vortex Chamber.

Diffuser C :

- The impeller is surrounded by a diffuser.
- The guide vanes are designed in such a way that the water from the impeller enters the guide vanes without shock.
- It reduces the vibration of the pump.
- Diffuser casing, the diffuser and the outer casing are stationary parts.

Priming of a centrifugal Pump:

The operation of filling the suction pipe, casing and a portion of delivery pipe with the liquid to be raised, before starting the pump is known as Priming
It is done to remove any air, gas or vapour from these parts of pump.

If a Centrifugal pump is not primed before starting air pockets inside impeller may give rise to vortices and causes discontinuity of flow

Losses in Centrifugal pump:

Hydraulic Losses:

- Shock or eddy losses at the entrance to and exit from the impeller
- Losses due to friction in the impeller
- Friction and eddy losses in the guide vanes/diffuser and casing

Mechanical Losses:

- Losses due to disc friction between the impeller and the liquid which fills the clearance spaces between the impeller and casing
- Losses pertaining to friction of the main bearing and glands.

Specific speed of Centrifugal Pump:

- It is the speed in revolutions per minute at which a geometrically similar impeller would deliver one cubic meter of liquid per second against a delivery head of one meter.

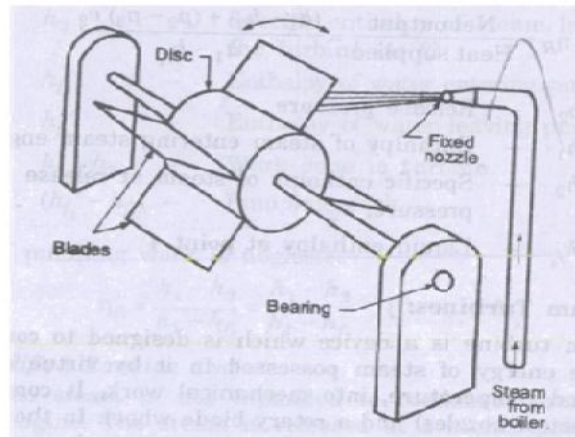
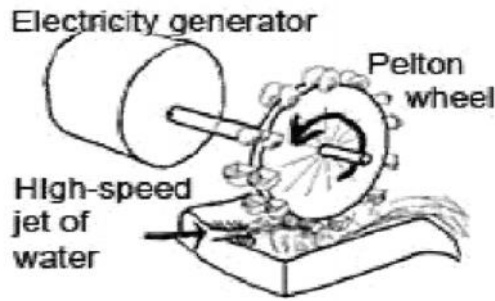

3.11 IMPULSE TURBINE:

- The steam coming out at a very high velocity through the nozzle impinges on the blades fixed on the periphery of rotor.
- The blades change the direction of steam flow without change in pressure.
- The resulting force causes the rotation of the turbine.

E.g Pelton wheel.

3.12 REACTION TURBINE:

- The high pressure steam from the boiler is passed through the nozzles.
- When the steam comes out through these nozzles, the velocity of steam increases relative to the rotating disc.

3.12.1 COMPARISION BETWEEN IMPULSE AND REACTION TURBINE:

S.No.	Impulse Turbine	Reaction Turbine
1	It consists of nozzles and moving blades	It consists of fixed blades which act as nozzles and moving blades
2	Steam is expanded completely in the nozzle. All the pressure energy is converted into kinetic energy	Steam is partially expanded in the fixed blades. Some amount of pressure energy is converted into kinetic energy
3	Pressure of steam is constant over the moving blades.	Pressure drop takes place in the moving blades.
4.	Because of high pressure drop in the nozzles, blade speed and steam speed are high.	Because of small pressure drop, blade speed and steam speed are less.
5.	Low Efficiency	High Efficiency
6.	Occupies less space per unit power	Occupies more space per unit power.

Unit 4

INTERNAL COMBUSTION ENGINES

4.1 INTRODUCTION:

Heat Engine:

- Heat Engine is a machine which converts heat energy supplied to it into mechanical work.
- Heat energy is supplied to the engine by burning the fuel.

4.2 CLASSIFICATION OF HEAT ENGINES:

- **Internal Combustion Engines (IC Engines)**

In IC engines, combustion of fuel takes place inside the engine cylinder. Examples: Diesel Engines, Petrol Engines, Gas engines.

- **External Combustion Engines (EC Engines)**

In EC engines, combustion of fuel takes place outside the working cylinder. Examples: Steam Engines and Steam turbines

IC Engines are classified into,

(1) **Cycle of operation (No of Strokes per cycle)**

- Two Stroke cycle Engines
- Four Stroke Cycle Engines

2) **Thermodynamic Cycle or Method of Heat addition:**

- Otto Cycle Engines (Combustion at constant volume)
- Diesel Cycle Engines (Combustion at constant Pressure)
- Semi Diesel Engines (Dual Combustion Engines)

(3) Types of Fuel Used :

- Petrol Engines
- Diesel Engines
- Gas Engines

(4) Ignition Method :

- Spark Ignition (SI)
- Compression Ignition (CI)

(5) Cooling System:

- Air cooled Engines
- Water Cooled Engines

(6) Valves Location :

- L head (Side valve) engine
- T Head (Side valve) engine
- I head (over head valve) engine
- F head (over head inlet and side exhaust) engine

4.3 MAIN COMPONENTS OF IC ENGINES:

Cylinder Block:

- It is the main block of the engine.
- It contains cylinders accurately finished to accommodate pistons
- The cylinder block houses crank, camshaft, piston and other engine parts.

- In water cooled engines, the cylinder block is provided with water jackets for the circulating cooling water.
- The materials used for cylinder are grey cast iron, aluminium alloys etc.,
- It is usually made of a single casting



Cylinder block of motor cycle



Cylinder block of car

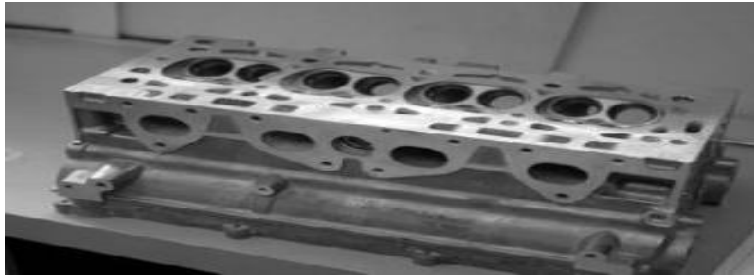

Cylinder Head:

- The cylinder head is bolted to the cylinder Block by means of studs.
- The water jackets are provided for cooling water circulation.
- The materials used for cylinder head are cast iron, aluminium alloy etc.,
- This is also generally made of single cast iron.

Cylinder Liners:

- The liner is a sleeve which is fitted into the cylinder bore.
- It provides wear resisting surface for the cylinder bores.

Liners are classified into:

- (a) Wet liner (b) Dry liner

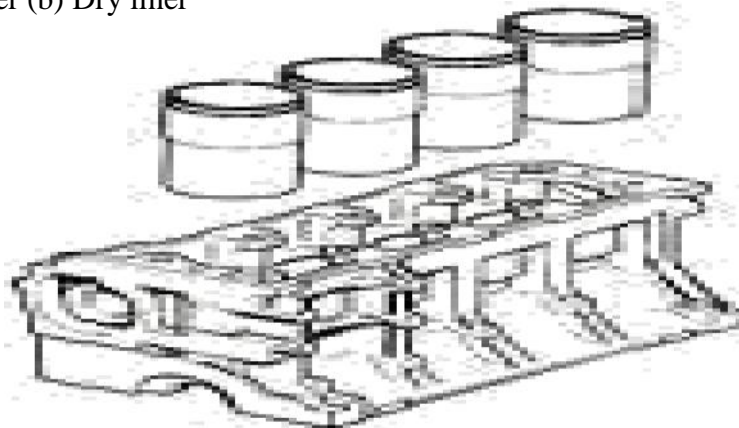

Cylinder Liners

Wet Liner : These liners are surrounded or wetted by cooling water. It provides wear resisting surface for the piston to reciprocate. Also it acts as a seal for the water jacket

Dry Liner : Dry liners have metal to metal contact with the cylinder block. They are not directly in touch with the cooling water.

Liner Materials:

- Liner material should withstand abrasive wear and corrosive. Chromium plated mild steel
- tubes are used as liners.



Crankcase : It may be cast integral with the cylinder

block. Some times, it is cast separately and then attached to the block. These materials are used for crank case are cast iron, aluminium alloys or alloy steels.

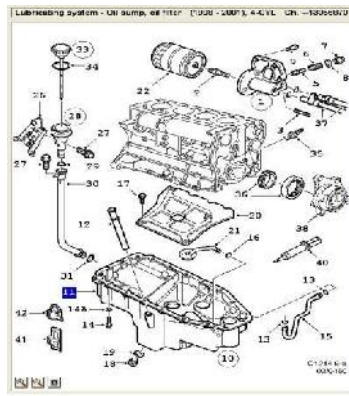

Oil pan or oil sump:

Oil sump is the bottom part of the engine. It contains lubricating oil. A drain plug is provided the oil sump to drain out the oil. It is made of the pressed sheet.

Piston :

The piston serves the following purposes

- It acts as a movable gas tight seal to keep the gases inside the cylinder
- It transmits the force of explosion in the cylinder to the crankshaft through the connecting rod.
- Some of the materials used for piston are cast iron, aluminium alloy, chrome nickel alloy, nickel iron alloy and cast steel.

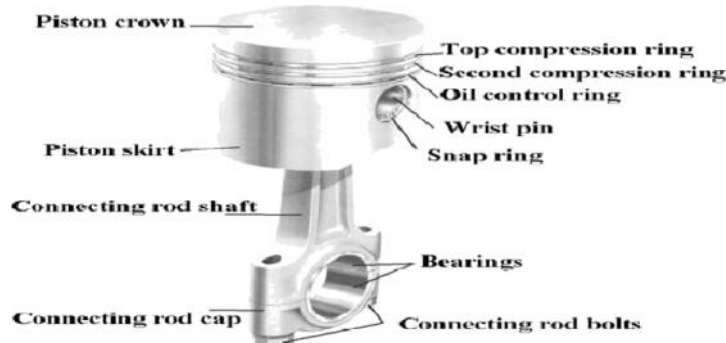

Piston rings :

Piston rings are inserted in the grooves provided in the piston. Two types of piston rings are used in the piston.

1. Compression rings
2. Oil rings or oil control rings



4.4 MAIN COMPONENTS OF IC ENGINE
Piston Rings (Compression and Oil rings)

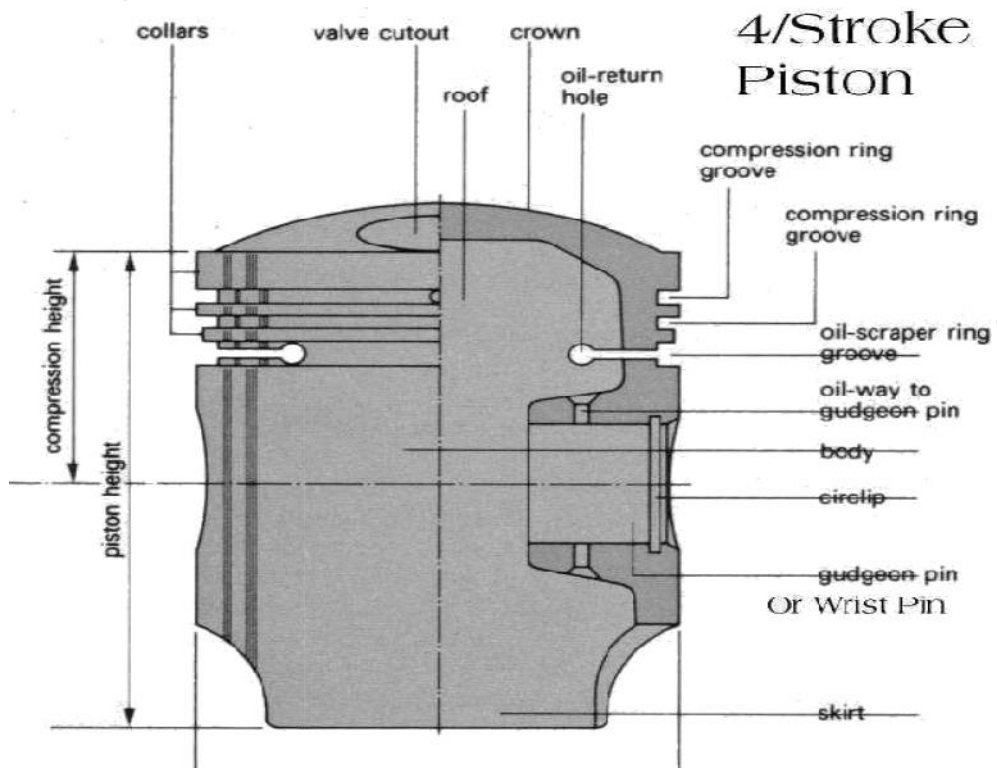

Compression rings :

- Compression rings provide an effective seal for the high pressure gases inside the cylinder.
- They prevent the leakage of high pressure gases from the combustion chamber into the crank case.
- Each piston is provided with at least two compression rings.

Oil rings :

- Oil rings wipe off the excess oil from the cylinder walls.
- It also returns excess oil to the oil sump, through the slots provided in the rings.

The materials used for piston rings should be wear resistant.

Normally piston rings are made of alloy steel iron containing silicon, manganese alloy steels etc.

Connecting Rod:

- It connects the piston and crank shaft.
- It transmits the force of explosion during power stroke to the crankshaft.
- The connecting rod has bearings at both ends.
- The small end of the connecting has a solid or split eye and contains a bush.
- This end is connected to the piston by means of a gudgeon pin.
- The other end is called as big end of the connecting rod.
- The connecting rods must withstand heavy thrusts.
- Hence it must have strength and rigidity.
- They are usually drop forged I sections.
- The materials used are plain carbon steel, aluminium alloys, nickel alloy steels etc,

Crank Shaft :

- It is the main rotating shaft of the engine.
- Power is obtained from the crank shaft.
- The crank shaft is combination with connecting rod converts reciprocating motion of the piston into rotary motion.
- The crank shaft is held in position by the main bearings.
- There are two main bearings to support the crank shaft.
- The materials used for crank shaft are billet steel, carbon steel, nickel chrome and other heat treated alloy steels.

Camshaft:

- Camshaft contains number of cams.
- It is used to convert rotary motion into linear or straight line motion.
- It has so many cams as the number of valves in an engine.
- An additional cam is also provided to drive the fuel pump.
- A gear is provided in the cam shaft to drive the distributor or oil pump.
- The opening and closing of the engine valves are controlled by the cams provided on the cam shaft.

4.5 PETROL ENGINES

Classification of Petrol Engines

- Two Stroke cycle Petrol Engines
- Four Stroke cycle petrol Engines

4.5.1 TWO STROKE CYCLE PETROL ENGINES:

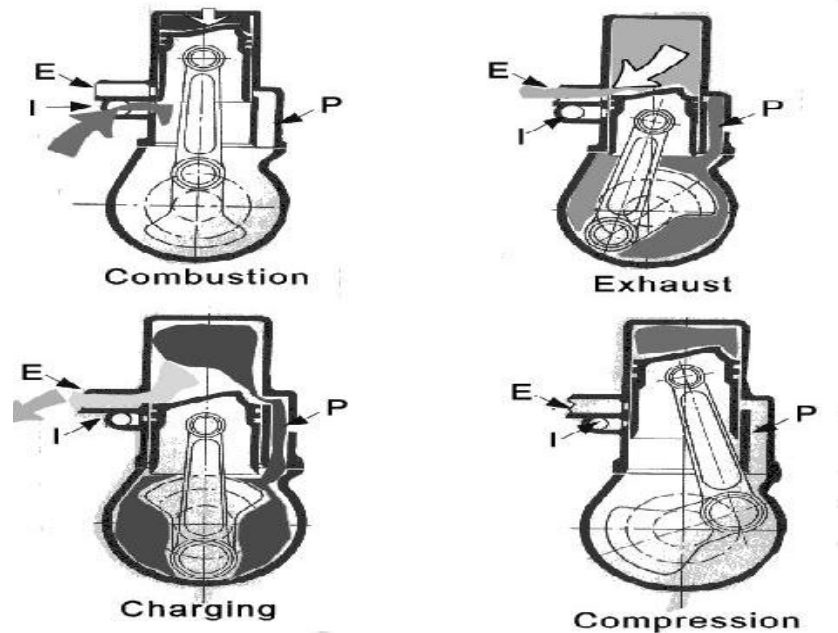

Two Stroke Cycle Petrol Engine - Construction

Construction :

- A piston reciprocates inside the cylinder
- It is connected to the crankshaft by means of connecting rod and crank
- There are no valves in two stroke engines, instead of valves ports are cut on the cylinder walls.
- There are three ports, namely inlet, exhaust and transfer ports.
- The closing and opening of the ports are obtained by the movement of piston. The crown of piston is made in to a shape to perform this.
- A spark plug is also provided.

First Stroke : (Compression, ignition and inductance) (Upward stroke of piston)

(a) compression:

- The piston moves up from Bottom Dead Centre (BDC) to Top Dead Centre (TDC)
- Both transfer and exhaust ports are covered by the piston.
- Air fuel mixture which is transferred already into the engine cylinder is compressed by moving piston.
- The pressure and temperature increases at the end of compression.

First Stroke : (Compression, ignition and inductance) (Upward stroke of piston)**(b) Ignition and Inductance:**

- Piston almost reaches the top dead centre
- The air fuel mixture inside the cylinder is ignited by means of an electric spark produced by a spark plug
- At the same time, the inlet port is uncovered by the plane.
- Fresh air fuel mixture enters the crankcase through the inlet port.

Second Stroke: (Downward Stroke of the engine) :**(c)Expansion and Crankcase compression**

- The burning gases expand in the cylinder
- The burning gases force the piston to move down. Thus useful work is obtained.
- When the piston moves down, the air fuel mixture in the crankcase is partially compressed. This compression is known as **Crank case compression**.

Second Stroke: (Downward Stroke of the engine) :**(d) Exhaust and transfer:**

- At the end of expansion, exhaust port is uncovered.
- Burnt gases escape to the atmosphere.
- Transfer port is also opened. The partially compressed air fuel mixture enters the cylinder through the transfer port.
- The crown of the piston is made of a deflected shape. So the fresh charge entering the cylinder is deflected upwards in the cylinder.
- Thus the escape of fresh charge along with the exhaust gases is reduced.

4.5.2 TWO STROKE CYCLE DIESEL ENGINES- CONSTRUCTION**Construction :**

- Two stroke cycle diesel engines require air supply
- This air is used to blow out the exhaust gases and to fill the cylinder with clean air
- This air is supplied by a blower or air compressor which is driven by engine itself.
- These engines may be valve or port type.
- A plate is provided in the crank case to admit air into the crank case.
- Transfer and exhaust ports are provided in the cylinder.
- These ports are covered and uncovered by the moving piston.

First Stroke (Upward Stroke of the piston)**(a) Compression and inductance:**

- The piston moves upwards from Bottom Dead Centre (BDC) to Top Dead Centre (TDC).
- Both transfer and exhaust ports are covered.
- Air which is transferred already into the engine cylinder is compressed by moving piston.
- The pressure and temperature of the air increases.
- At the same time, fresh air is admitted into the crankcase through the plate valve (reed valve)

First Stroke (Upward Stroke of the piston)**(b) Ignition and inductance.**

- Piston almost reaches the top dead centre.
- The fuel is injected into the hot compressed air inside the cylinder. The fuel mixed with hot air and burns.
- The admission of fresh air into the crankcase continues till the piston reaches the top centre.

Second Stroke (Downward Stroke of the piston)**(c) Expansion and crank case compression:**

- The burning gases expand in the cylinder.
- Burning gases force the piston to move down. Thus useful work is obtained.
- At the same time, the air in the crank case is compressed by the movement of piston.
- All the ports and the plate valve are in closed position

Second Stroke (Downward Stroke of the piston)**(d) Exhaust and Transfer:**

- At the end of expansion, the exhaust port is uncovered.
- The burnt escape to the atmosphere through the exhaust port.
- Transfer port is also uncovered shortly after the exhaust port is opened.
- The partially compressed air from crank case enters the cylinder the transfer port.
- This air is deflected upwards by the deflected shape of the piston.
- Thus the entering air helps in forcing out the combustion products from the cylinder
- The plate valve remains during this period.

4.5.3 FOUR STROKE CYCLE PETROL ENGINES**Construction :**

- A piston reciprocates inside the cylinder
- The piston is connected to the crank shaft by means of a connecting rod and crank.
- The inlet and exhaust valves are Mounted on the cylinder head.
- A spark is provided on the cylinderHead.
- The fuel used is petrol

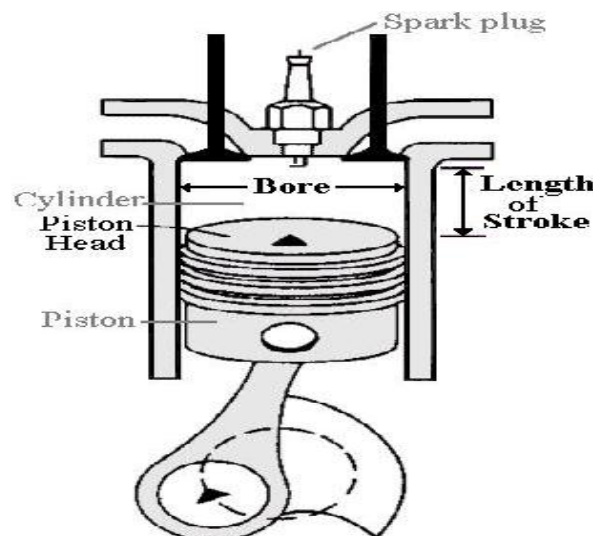

Four Stroke Petrol Engine- Working

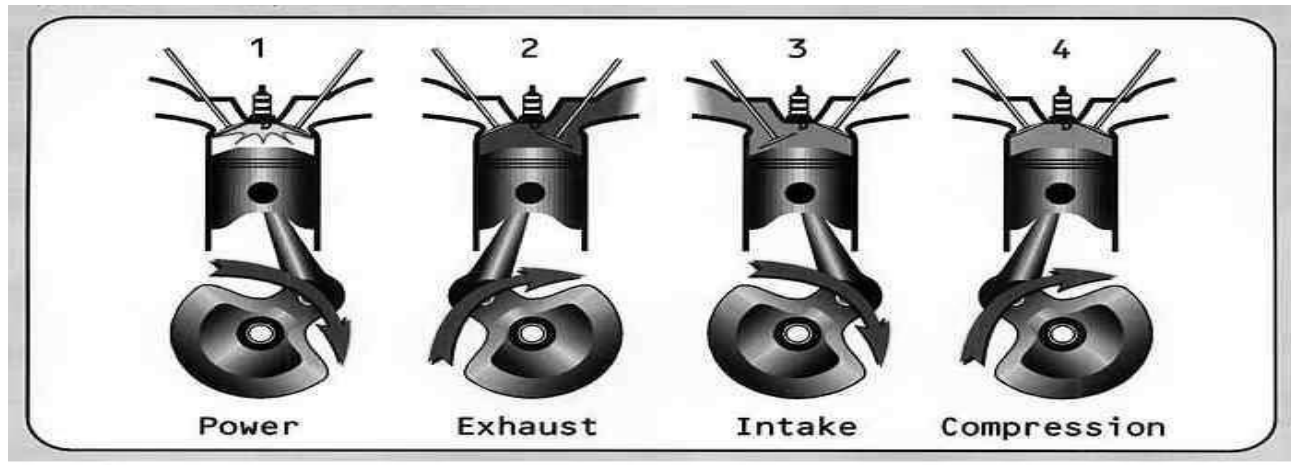

(a) Suction Stroke (First Stroke of the Engine)

- Piston moves down from TDC to BDC
- Inlet valve is opened and the exhaust valve is closed.
- Pressure inside the cylinder is reduced below the atmospheric pressure.
- The mixture of air fuel is sucked into the cylinder through the inlet valve.

(b) Compression Stroke : (Second Stroke of the piston)

- Piston moves up from BDC to TDC
- Both inlet and exhaust valves are closed.
- The air fuel mixture in the cylinder is compressed.

(c) Working or Power or Expansion Stroke: (Third Stroke of the Engine)

- The burning gases expand rapidly. They exert an impulse (thrust or force) on the piston. The piston is pushed from TDC to BDC
- This movement of the piston is converted into rotary motion of the crankshaft through connecting rod.
- Both inlet and exhaust valves are closed.

(d) Exhaust Stroke (Fourth stroke of the piston)

- Piston moves upward from BDC
- Exhaust valve is opened and the inlet valve is closed.
- The burnt gases are forced out to the atmosphere through the exhaust valve (Some of the burnt gases stay in the clearance volume of the cylinder)
- The exhaust valve closes shortly after TDC
- The inlet valve opens slightly before TDC and the cylinder is ready to receive fresh charge to start a new cycle.

Summary :

- Compression ratio varies from 5 to 8
- The pressure at the end of compression is about 6 to 12 bar.
- The temperature at the end of the compression reaches 250° C to 350° C

4.5.4 FOUR STROKE DIESEL ENGINE

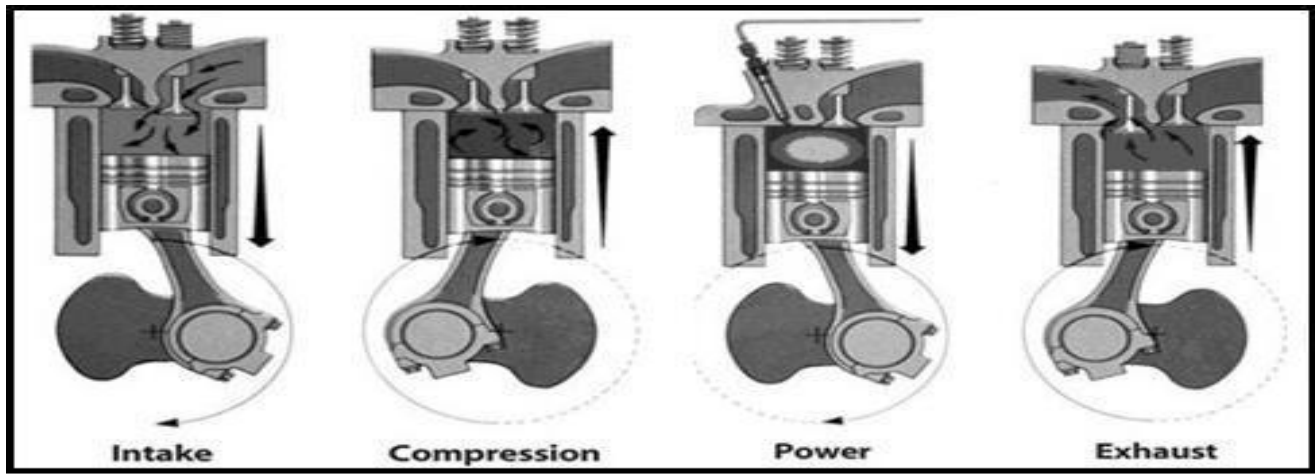

Construction:

- A piston reciprocates inside the cylinder
- The piston is connected to the crankshaft by means of a connecting rod and crank.
- The inlet and exhaust valves are mounted on the cylinder head.
- A fuel injector is provided on the cylinder head
- The fuel used is diesel.

(a) Suction Stroke (First Stroke of the piston)

- Piston moves from TDC to BDC
- Inlet valve is opened and the exhaust valve is closed.
- The pressure inside the cylinder is reduced below the atmospheric pressure.
- Fresh air from the atmosphere is sucked into the engine cylinder through air cleaner and inlet valve.

(b) Compression stroke (Second stroke of the piston)

- Piston moves from BDC to TDC
- Both inlet and exhaust valves are closed.
- The air is drawn during suction stroke is compressed to a high pressure and temperature

(c) Working or power or expansion stroke (Third stroke of the piston)

- The burning gases (products of combustion) expand rapidly.
- The burning gases push the piston move downward from TDC to BDC
- This movement of piston is converted into rotary motion of the crank shaft through connecting rod.
- Both inlet and exhaust valves are closed.

(d) Exhaust Stroke (Fourth stroke of the piston)

- Piston moves from BDC to TDC
- Exhaust valve is opened the inlet valve is closed.
- The burnt gases are forced out to the atmosphere through the exhaust valve. (some of the burnt gases stay in the clearance volume of the cylinder)
- The exhaust valve closes shortly after TDC
- The inlet valve opens slightly before TDC and the cylinder is ready to receive fresh air to start a new cycle.

4.6 SCAVENGING

- It is the process of forcing out the burnt exhaust gases from the cylinder for admitting the fresh charge into the cylinder.
- This action takes place in the two stroke cylinder.

4.6.1 SCAVENGING PROCESS

- The charge (air fuel mixture or air) enters the engine cylinder from the crank case at a pressure higher than the exhaust gases.
- This fresh charge forces the exhaust gases to the atmosphere through the exhaust port.
- During the period both the transfer and exhaust ports are kept open for a short period.
- Hence there is a possibility of the fresh charge escaping out with the burnt gases.
- This is over come by designing the piston to have a deflected shape.
- This shape of piston deflects the fresh charge upward in the engine cylinder.
- It also helps out in forcing out the exhaust gases to atmosphere.
- This process is known as **Scavenging**.

4.7 COMPARISON BETWEEN SI AND CI ENGINES (GENERAL COMPARISON):

S. NO.	Spark Ignition Engines (SI)	Compression Ignition Engines (CI)
1	It draws air fuel mixture into the cylinder during suction stroke	It draws only air into the cylinder during suction stroke.
2	Petrol engines operate with low pressure and temperature	Diesel engines operate with high pressure and temperature
3.	Pressure ranges from 6 to 12 bar Temperature ranges from 250°C to 300°C	Pressure ranges from 35 to 40 bar Temperature ranges from 600oC to 700oC
4	It is fitted with carburettor and spark plugs	It is fitted with fuel injection pump and injectors
5	The burning of fuel takes place at constant volume	The burning of fuel takes place at constant pressure
6.	Ignition of air fuel mixture takes place by an electric spark produced by spark plug	Ignition of air fuel takes placed by a injection of fuel into the hot compressed air.
7	Petrol engines are quality governed engines. The speed of petrol engines are controlled by varying the quantity of air fuel mixture.	Diesel engines are quantity governed engines. The speed of diesel engines is controlled by varying quality of air fuel mixture. (rich or weak mixture)
8	Petrol engines are widely used in automobiles and aeroplanes etc.,	Diesel engines are widely used in heavy vehicles, such as buses, lorries, trucks etc.,

4.8 COMPARISON BETWEEN SI AND CI ENGINES (MERITS AND DEMERITS):

S.No.	Spark Ignition Engines (SI)	Compression Ignition Engines (CI)
1	Merits: Otto cycle is employed in petrol engine. Otto cycle is more efficient for a given compression ratio.	Demerits: Diesel engines works on diesel cycle. Diesel cycle is less efficient than Otto cycle for a given compression ratio.
2	Operating speed is more. Speed range is 3000 to 6000 rpm	Operating speed is less. Speed range is 400 to 3500 rpm.
3	Starting is easy, since cranking effort required is less	Starting is difficult since more cranking effort is required.
4	Merits: Initial cost and maintenance cost are less	Demerits: More initial and maintenance costs since the construction is heavy and sturdy.
5	Produces less noise.	Produces more noise.
6	Weight per unit power is less	Weight per unit power is more.
7	Specific fuel consumption is more.	Specific fuel consumption is less
8	The fuel used is petrol. It is costlier than diesel. It is volatile and fire hazard is more	The fuel used is diesel. It is cheaper than petrol. It is less volatile and fire hazard is less.

4.9 COMPARISON BETWEEN FOUR STROKE CYCLE AND TWO STROKE CYCLE ENGINE (MERITS AND DEMERITS):

S.No.	Two Stroke Cycle Engine	Four Stroke Cycle Engine
1	Merits: One power stroke in one revolution of the crankshaft	Demerits: One power stroke in two revolutions of the crank shaft
2	Power developed for the same engine speed theoretically twice that of a four stroke engine	Power developed for the same engine speed is theoretically half that of two stroke engine.
3	Simple design and lighter in construction for the same power	For the same power complicated design and heavier in construction
4	Merits: Uniform torque is obtained. Hence a lighter fly wheel can be used	Demerits: Non uniform torque on the crankshaft. Hence a heavier flywheel is required for balancing.
5	Design of ports is simpler. Hence initial cost is less	Design valve mechanism is difficult. Hence initial cost is more.
6	Mechanical efficiency is high. No moving parts like cam, follower, rocker arm valves etc.,	Mechanical efficiency is less. Power is lost due to friction caused by valve mechanism
7	Merits: Starting is easy	Demerits: Starting is not so easy
8	These engines are generally air cooled	These engines are generally water cooled.

4.10 COMPARISON BETWEEN FOUR STROKE CYCLE AND TWO STROKE CYCLE ENGINE (MERITS AND DEMERITS):

S.No.	Two Stroke Cycle Engine	Four Stroke Cycle Engine
1	DeMerits: Consumption of lubricating oil is more, because less time is available to remove the heat	Merits: Consumption of lubricating oil is less, because more time is allowed for removing heat from the cylinder.
2	More wear and tear of moving parts.	Less wear and tear of parts is less
3	Some of the fresh air fuel mixture may escape with exhaust gases. Hence fuel consumption is more	Fuel cannot escape with exhaust gases. Hence fuel consumption is less.
4	DeMerits: Thermal efficiency is less.	Merits: Thermal efficiency is more.
5	It produces more noise due to sudden release of exhaust gases	Noise is less is less. Exhaust gases are released in separate stroke.
6	Scavenging is poor, since exhaust port is open only for a short time	Scavenging is better, since there is a separate exhaust stroke for the removal of exhaust gases
7	Merits: Poor scavenging leads to mixing of fresh charge with exhaust gases. This results in poor performance, slow running	Demerits: Better performance and efficiency is more
8	Used in light vehicles, like bikes, scooters, mopeds, etc.,	Used in heavy vehicles, like buses, lorries, trucks etc.,

4.11 I.C ENGINE TERMINOLGOGY

The standard terms used in I.C Engines are

1. Bore:

Inside diameter of the cylinder is termed as Bore.

2. Top Dead Center (TDC):

The extreme position reached by the piston at the top of the cylinder in the vertical engine is called Top Dead center.

3. Bottom Dead Center (BDC):

The extreme position reached by the piston at the Bottom of the cylinder in the vertical engine is called Bottom Dead center.

4. Stroke:

The nominal distance travelled by the piston in the cylinder between the extreme upper and lower positions of the piston (TDC &BDC) is termed as stroke.

5. Compression ratio (r):

It is the ratio of Maximum cylinder volume to the Clearance volume.

6. Cylinder volume (v):

It is the sum of swept volume and the Clearance volume.

$$V = V_s + V_c$$

7. Swept volume (Vs):

It is the volume of space generated by the movement of piston

from one dead center to another dead center.

8. Clearance Volume(V_c):

It is the space in the cylinder, when the piston is at Top Dead Center

4.11.1 MAJOR PARTS OF AN IC ENGINE

1. Cylinder

- It is a round cylindrical casting in which a piston slides in and out to make strokes.
- Combustion take place inside the cylinder. The cylinder is closed by a cylinder head.

Material: Grey cast iron, Aluminium

2. Cylinder head

It is fitted to the top of the cylinder. It has inlet and outlet valves, spark plug, Fuel injector, Water jackets.

Material: C.I, Aluminium

3. Piston

It is a device which transmits the energy (or) force of the expanding gas to the connecting rod. It slides up and down inside the cylinder.

Material: C.I, Aluminium alloy, Cast steel

4. Piston rings

Piston rings are inserted in the grooves of piston. There are two types of rings.

- 1) Oil ring (One ring is used)
- 2) Compression ring(Two ring is used)

5. Connecting rod

It converts the reciprocating motion of the piston into rotary motion of crankshaft. The small end of the connecting rod is connected to piston and the big end is connected to the crankshaft.

Material: Plain carbon steel, Aluminium alloys

6. Crank shaft

It is the device used for getting power from the motion of the piston and connecting rod and this power is applied to the flywheel.

Material: Alloys steel.

7. Camshaft

It operates the opening and closing of the engine valves. It has number of cams which are driven by crank shaft through timing gears. The function of the cam is to convert the rotary motion into the linear reciprocating motion

Material: Alloys steel

8. Crank case

It is the bottom portion of the I.C engine and holds the cylinder and the crank case. It also serves as a pump for the lubricating oil.

Material: Aluminium alloy, Cast iron

9. Flywheel:

It is a big wheel attached with crankshaft. It maintains the speed of the engine.

10. Valves: The function of the valve is to admit the fresh charge in the cylinder and to send the exhaust gases out. There are two valves namely inlet valve and outlet valve.

Material: Inlet valve: Nickel chrome.

Outlet valve: Nickel chrome, Stainless steel etc

11. Water Jackets

Water jackets are provided in the cylinder head. The purpose of water jackets is to keep the walls of the engine cool.

4.12 STEAM BOILERS

- Generates steam by transferring heat by burning of fuel to water.
- Energy released by burning fuel (solid, liquid or gaseous) is transferred to the water in the boiler.

Classification of boilers:

The steam boilers are classified as

- **According to flow of water and hot gases.**
 1. Fire Tube Boilers
 2. Water Tube Boilers
- **According to the method of firing.**
 1. Internally fired boilers
 2. Externally fired boilers
- **According to the Pressure developed**
 1. Low pressure boilers
 2. High pressure boilers

In fire tube boilers,

- The hot gases pass through the tubes surrounded by water.
- The water is get heated up and converted into steam
- The exhaust gases are sent to atmosphere through chimney.

E.g Locomotive boiler, Lancashire boiler.

4.12.1 FIRE TUBE & WATER TUBE BOILERS

According to flow of water and hot gases:

In **water tube** boilers,

- Water is circulated through number of tubes and the hot flue gases flow over these tubes.
- A number of tubes are connected with boiler drum through headers.

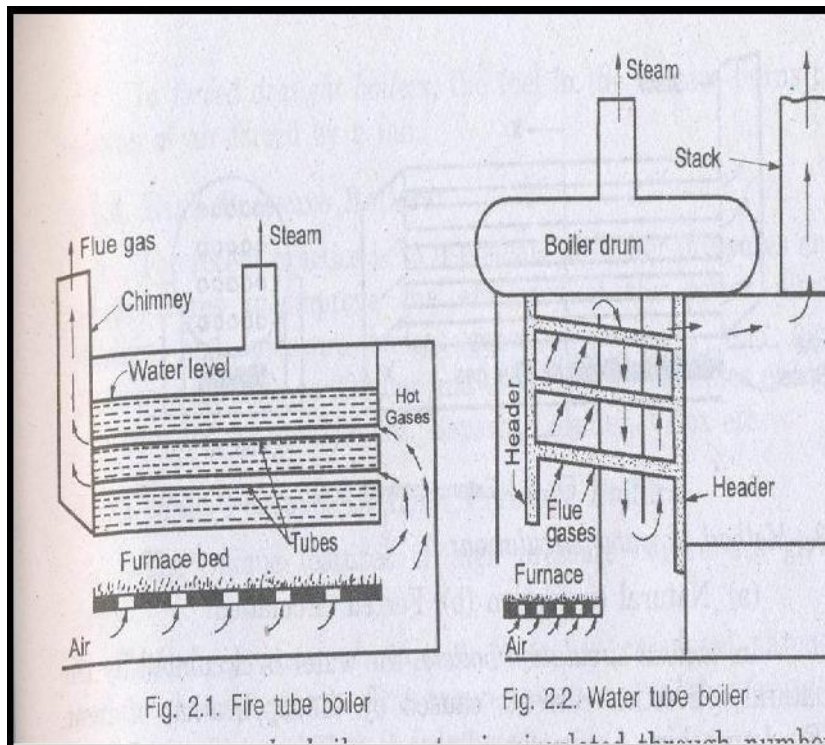

- The hot gases flow over these tubes many times before escaping through the stack.
- The water is converted into steam and steam occupies steam space.

E.g. Babcock & Wilcox, stirling, BHEL boiler, Velox, Lamont, Lo-effler boilers.

According to the method of firing:

In internally fired boilers, the furnace grate is provided inside the boiler shell. (E.g Lancashire, Locomotive boilers) In externally fired boilers,

- The furnace grate is provided outside or built under the boiler shell.

4.12.2 INTERNALLY FIRED BOILER:

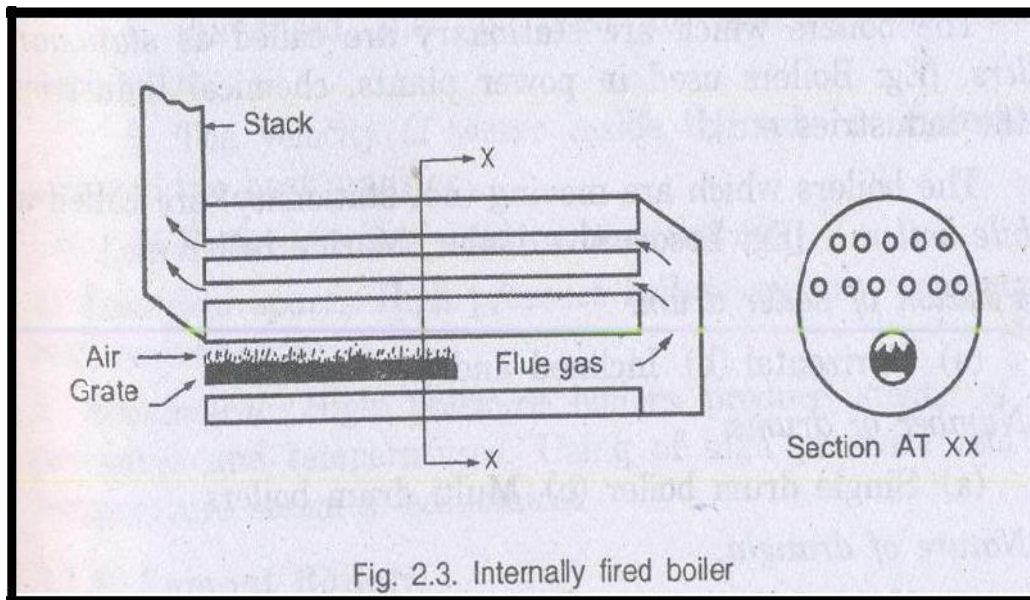

4.12.3 EXTERNALLY FIRED BOILER:

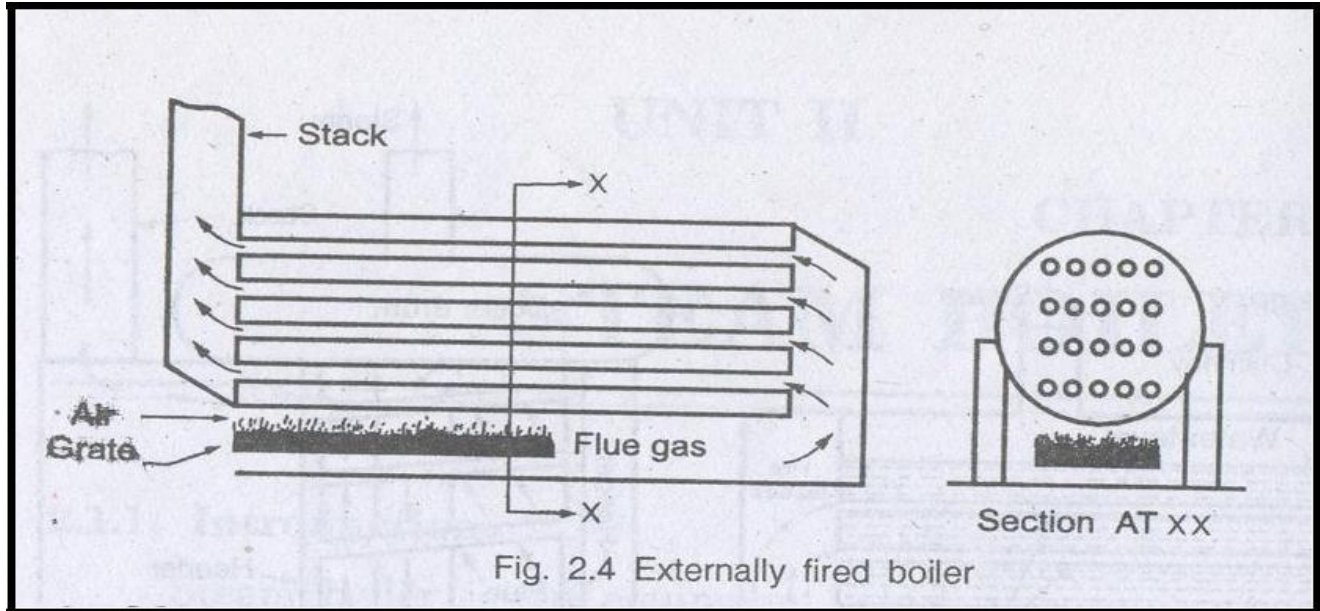

According to the Pressure Developed:

In **Low Pressure Boilers**, Steam is produced at a pressure lower than 80 bar. (E.g. Cochran, Lancashire, Locomotive)

In **High Pressure Boilers**, Steam is produced at a pressure more than 80 bar. (E.g. Lamont, Velox, Benson, Lo-effler boiler)

4.12.4 COCHRAN BOILER:

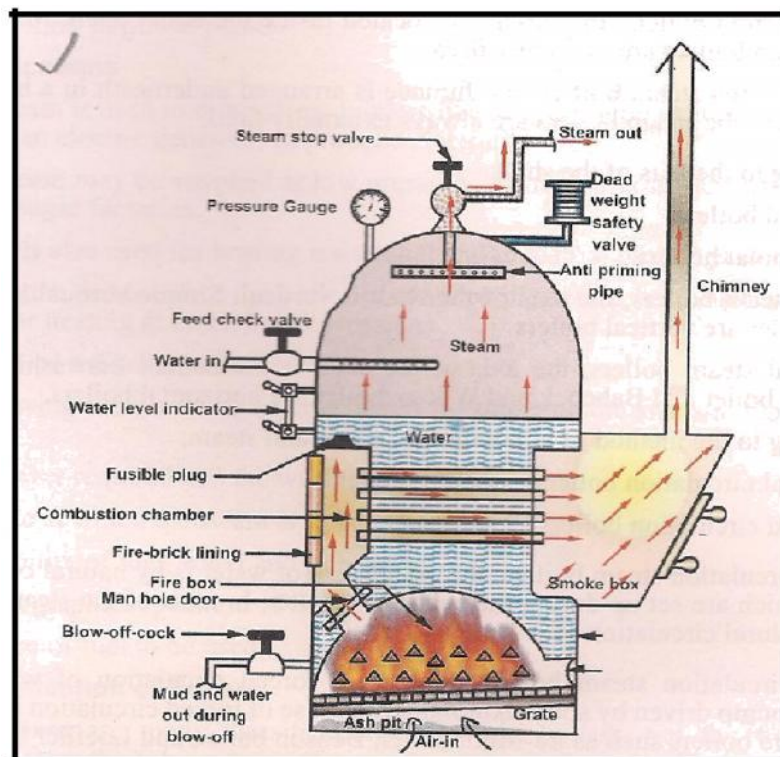

- Coal is fed into the grate through the fire hole and burnt.
- Ash formed during the burning is collected in the ash pit provided just below the grate.
- Ash is then removed manually.
- The hot gases from the grate pass through the combustion chamber to the horizontal fire tubes and transfer the heat by convection.
- The flue gases coming out of fire tubes pass through the smoke box and escape to the atmosphere through the chimney.
- Smoke box is provided with a door for cleaning the fire tubes and smoke box.
- The working pressure and steam capacity of Cochran boiler are 6.5 bar and 3500 kg /hr respectively.

4.12.5 LAMONT BOILER:

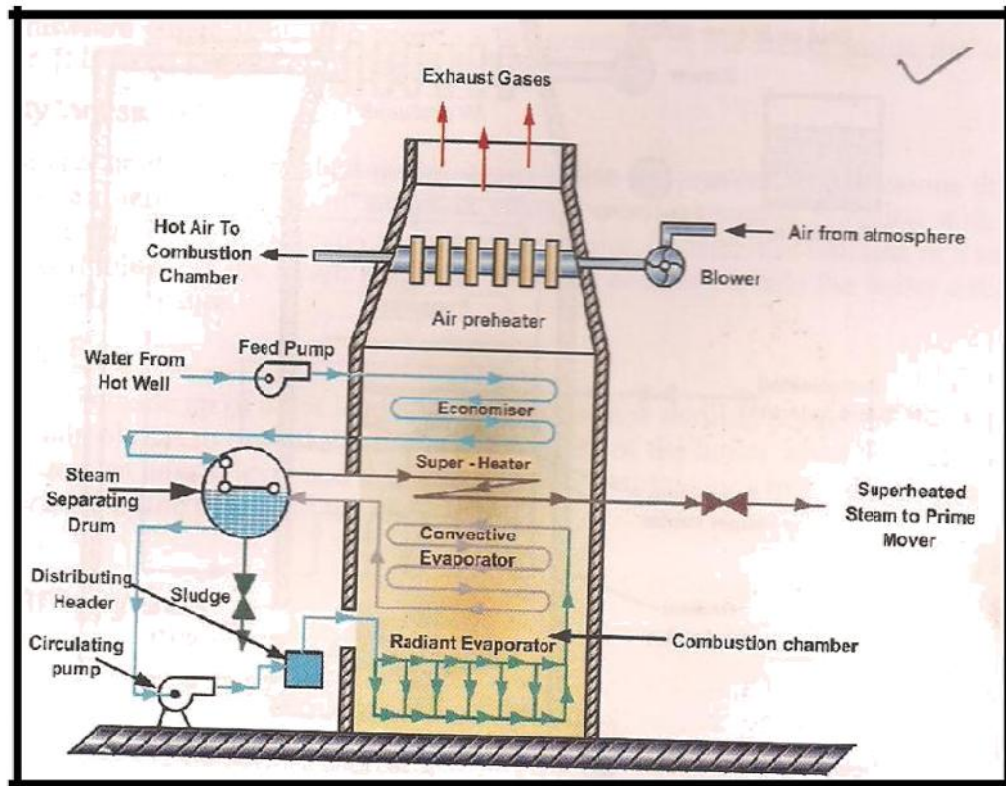

- It is a water tube, forced circulation and externally fired high pressure boiler.
- The capacity of the plant is 50 tonnes/hr
- Pressure of the steam generated is 170 bar.
- Temperature of the steam produced is 500° C

Working:

- Feed water is pumped to the boiler by the feed pump through the economiser.
- Economiser preheats the feed water by using hot gases leaving the boiler.
- The circulating pump circulates the water from the drum under high pressure to prevent the tubes from being overheated
- Water is evaporated into steam when passing through these tubes.
- The water and steam from the tube enters the boiler drum where the steam is separator.
- This steam is passed through a convection superheater and the steam is superheated by the flue gases.

- This super heated steam is supplied to the prime mover through steam outlet.
- The water level in the drum is kept constant by pumping the feed water into the boiler drum.
- The air is preheated by the flue gases before entering the combustion chamber to aid the combustion of the fuel.
- This type of boiler has a working pressure of 170 bar.
- They can produce the steam at the rate of 45000 kg per hour.

4.13 BOILER MOUNTINGS & ACCESSORIES:

Boiler Mountings:

- Boiler mountings are primarily **intended for the safety of the boiler** and for complete control of steam generation process.

Boiler Accessories :

- Boiler accessories are installed **to increase the efficiency of the boiler plants** to help in proper working of boiler unit.

Boiler Mountings:

- Dead weight safety valve.
- Spring loaded safety valve
- Fusible plug
- Pressure gauge

Dead Weight Safety Valve:

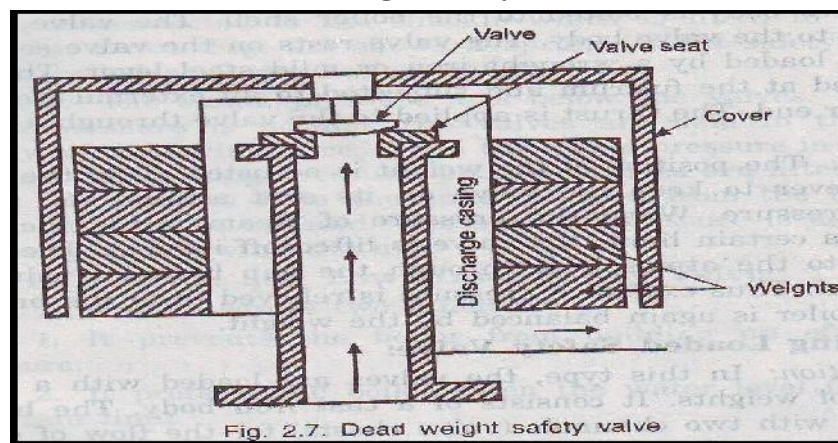

Dead Weight Safety Valve:

- Weights are placed sufficiently in the weight carrier.
- The total load on the valve includes the weight of the carrier, the weight of the cover, the weight of the discs and the weight of the valve itself.
- When the steam pressure exceeds the normal limit, the valve along with the weight carrier is lifted off its seat.
- Thus the steam escapes through the discharge pipe.

Spring Loaded Safety Valve:

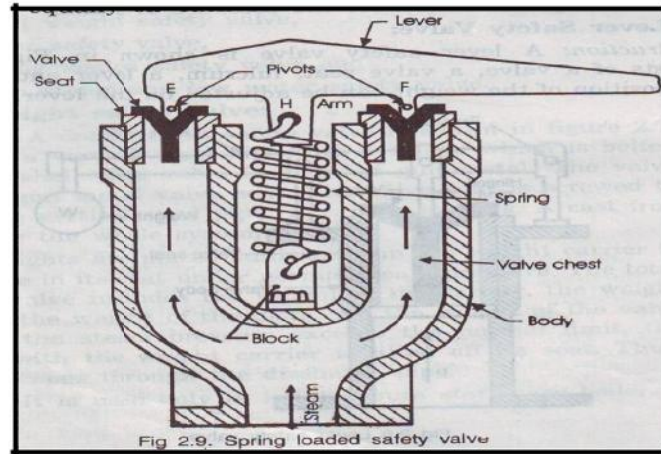

- The steam pressure acts below the valves.
- When the steam pressure is normal the valves are held in their seats tightly by the spring force.
- When the steam pressure in the boiler exceeds the working pressure, both valves are lifted off their seats.
- Thus the steam from the boiler escapes the boiler and steam pressure is reduced.
- The blow off pressure is adjusted by loosening or screwing the nut.

Fusible Plug:

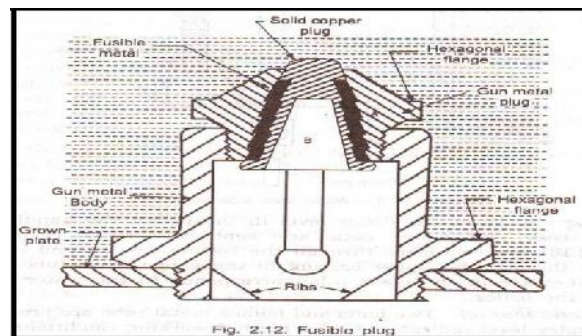

- Under normal working conditions, the fusible plug is completely covered with water.
- Hence the temperature of the plug is not increased appreciably during combustion process.
- When the water level falls below the safe limit the fusible plug is uncovered from water and exposed to steam.
- The furnace heat over heats the plug and it melts the fusible metal and copper plug falls down.
- Due to this water steam mixture rushes into the furnace and the fire is extinguished.

Bourdan Tube Pressure Gauge

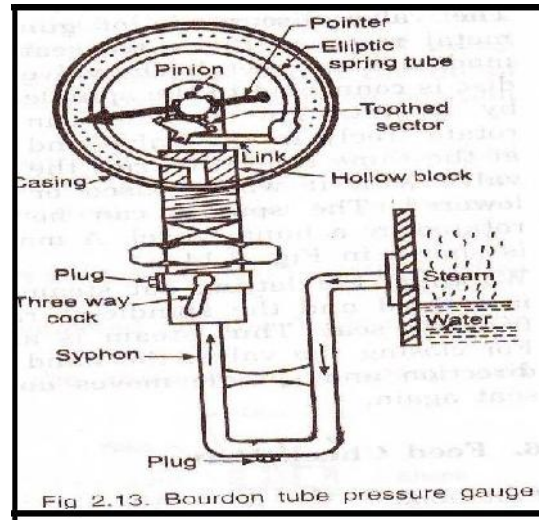

- The steam pressure is applied to the
- The elliptical cross section of the tube to straighten out slightly.
- The closed end of the Bourdon tube moves.
- This movement actuates the toothed sector and pinion rotates.
- The pointer is mounted on the pinion. Hence the pointer moves on the graduated dial in clockwise, to indicate the steam pressure.

Water Level Indicator

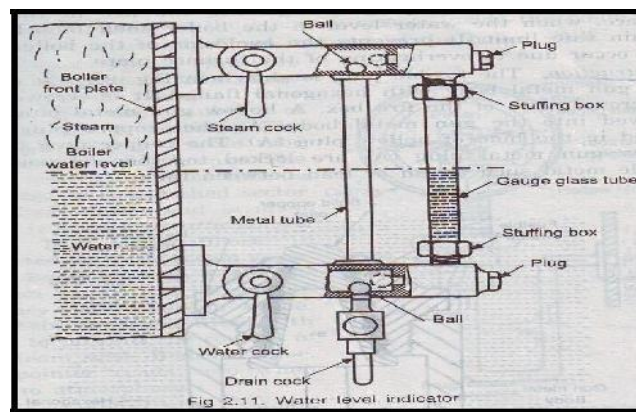

- To know the water level in the boiler the handles of the steam cock and water cock are kept in vertical positions.
- Water rushes through the bottom casting and steam rushes through the upper casting to the gauge glass tube.
- The level of water corresponds to the water level in the boiler.

4.14 BOILER ACCESSORIES

- Economiser
- Air Preheater
- Super Heater
- Steam Separator
- Steam Trap Feed Pump

Economiser:

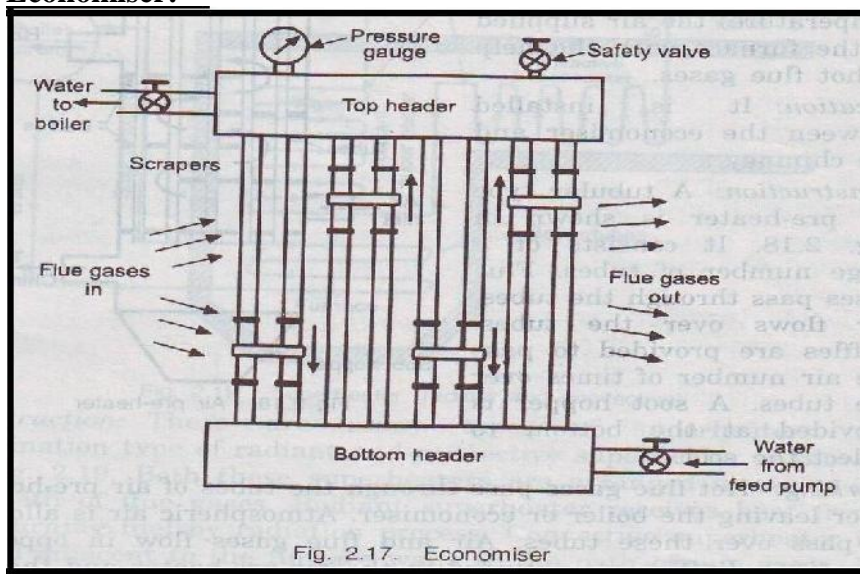

- The feed water is pumped to the bottom header and this water is carried to the top header number of vertical tubes.
- Hot flue gases are allowed to pass over the external surface of the tubes.
- The feed water which flows upward in the tubes is heated by the flue gases.
- This preheated water is supplied to the water.
- Scrapers are slowly moved up and down to clean the surface of the tubes.

Air Preheater:

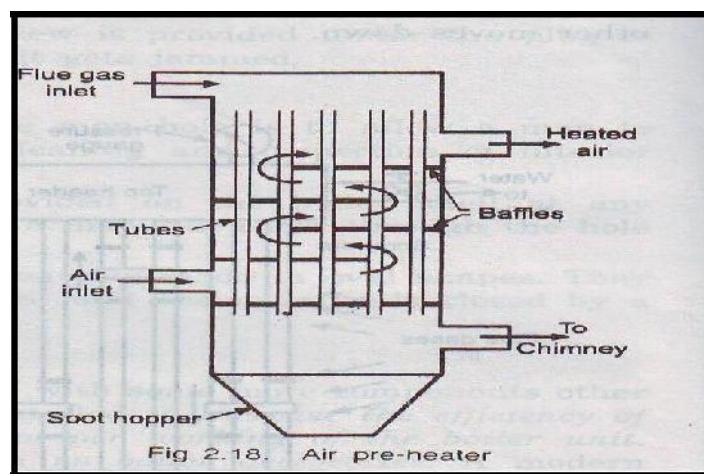

- Hot flue gases pass through the tubes of air preheater after leaving the boiler or economiser.
- Air and flue gases flow in opposite directions.
- Baffles are provided in the air preheater and the air passes number of times over the tubes.
- Heat is absorbed by the air from the flue gases.
- This preheated is supplied to the furnace to aid combustion.

Super heater

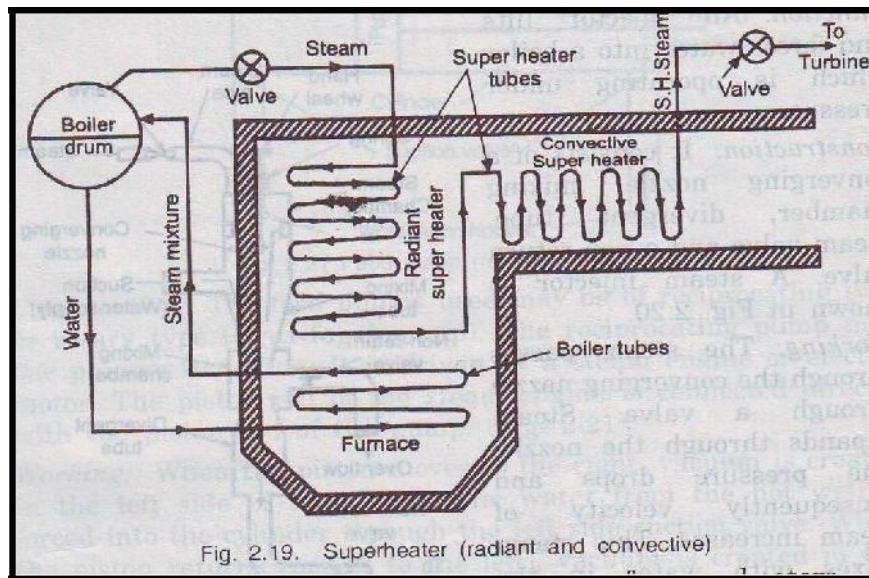

- Steam stop valve is opened.
- The steam from the evaporator drum is passed through the super heater tubes.
- First the steam passed through the radiant super heater and then to the convective super heater.
- The steam is heated when it passes through these super heaters and converted into the super heated steam.
- This superheated steam is supplied to the turbine through the valve.
- The steam is allowed into the separator.
- The steam strikes the baffle plates and the direction of flow is changed.
- As a result, heavier particles in steam falls down to the bottom of the separator.
- The separated steam is free from water particles.
- It is passed to the turbine or engine through the outlet pipe.

Steam Separator

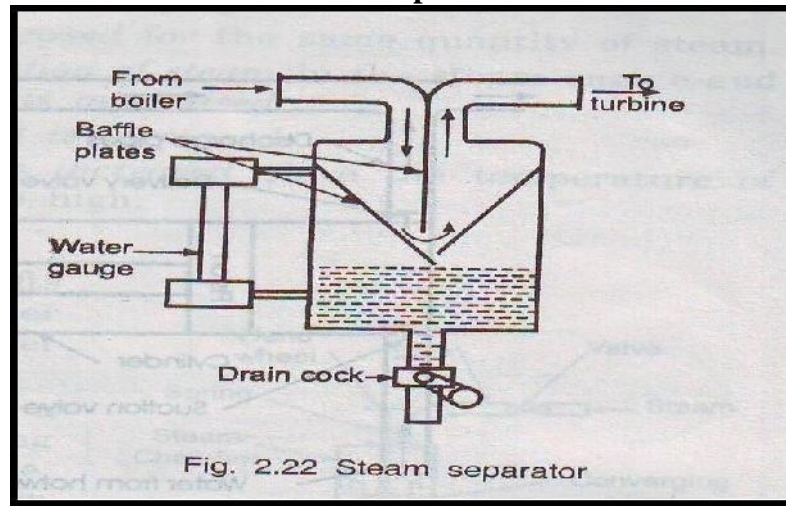

Stream Trap

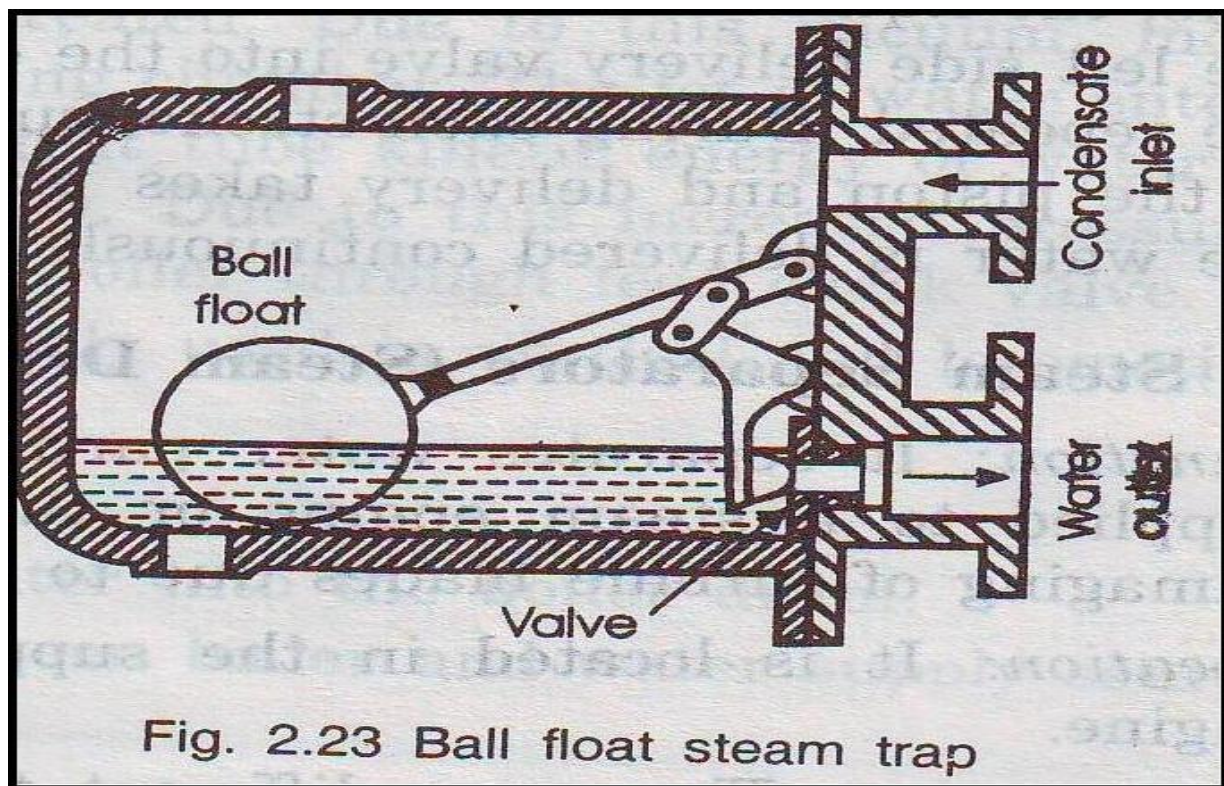

- The condensed water enters the steam trap by gravity.
- When the water level in the trap rises high enough, the ball float is lifted.
- This causes the valve to open and the water is discharged through the outlet.
- After the discharge of water, the float moves down.
- This causes the valve to close again.

4.15 DIFFERENCES BETWEEN BOILER MOUNTINGS AND ACCESSORIES:

Sl. No.	Boiler Mountings	Boiler Accessories
1	Mountings are fitted for the safety of the boiler.	Accessories are fitted to increase the efficiency
2	They form integral parts of the boiler	They are not integral part of the boiler
3	They are usually mounted on the boiler shell	They are usually installed outside the boiler shell
4	A boiler should not be operated without mountings	A boiler can be operated without accessories

UNIT V

REFRIGERATION AND AIRCONDITIONING

5.1 REFRIGERATION:

- It is defined as the process of providing and maintaining a temperature well below that of surrounding atmosphere.
- In other words refrigeration is the process of cooling substance.

Refrigerators and heat pumps:

- If the main purpose of the machine is to cool some object, the machine is named as refrigerator.
- If the main purpose of machine is to heat a medium warmer than the surroundings, the machine is termed as heat pump.

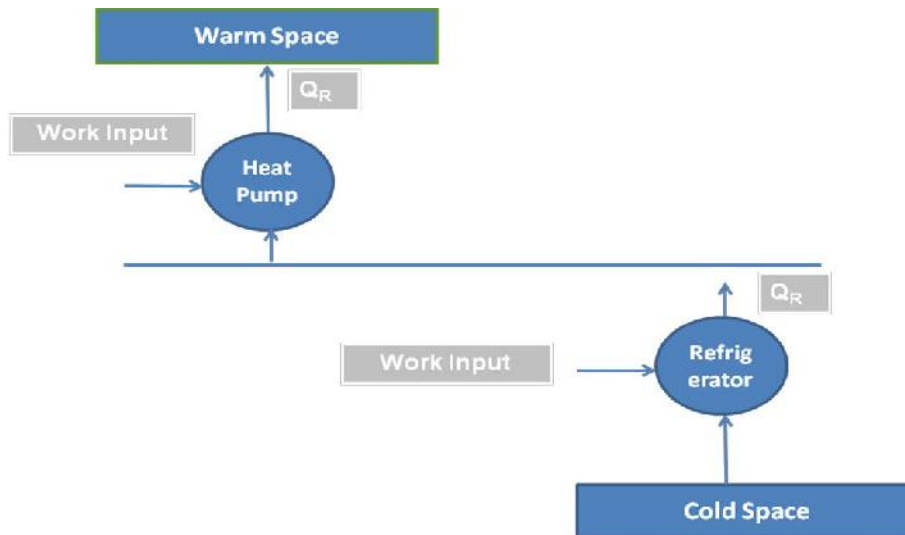

Terminologies of Refrigeration:

Refrigerating Effect (N):

It is defined as the quantity of heat extracted from a cold body or space to be cooled in a given time.

$N = \frac{\text{Heat extracted from the cold space}}{\text{Time taken}}$

Specific Heat of water and ice :

It is the quantity of heat required to raise or lower the temperature of one kg of water (or ice), through one kelvin or (1⁰ c) in one second.

Specific heat of water, $C_{pw} = 4.19 \text{ kJ/kg K}$
 Specific heat of ice, $C_{pice} = 2.1 \text{ kJ/kg K}$.

Capacity of a Refrigeration Unit :

- Capacity of a refrigerating machines are expressed by their cooling capacity.
- The standard unit used for expressing the capacity of refrigerating machine is ton of refrigeration.

- One ton of refrigeration is defined as, “the quantity of heat effect) to freeze one ton of water Heat extracted from at 0°C = latent heat of ice into one ton of ice in a duration of 24 hours at 0°C ”.

Latent heat of ice= 336 kJ/kg i.e., 336 kJ of heat should be extracted one kg of water at 0°C to convert it into ice.

$$\begin{aligned}\text{One ton of refrigeration} &= 336 \times 1000 \text{ kJ} / 24 \text{ hrs.} \\ &= 336 \times 1000 \text{ kJ} / \text{min} \\ &\quad 24 \times 60\end{aligned}$$

$$\begin{aligned}\text{One ton of refrigeration} &= 233.333 \text{ kJ/min} \\ &= 3.8889 \text{ kJ/sec}\end{aligned}$$

Co efficient of Performance

It is defined as the ratio of heat extracted in a given time (refrigerating effect) to the work input.

$$\text{Co efficient of performance} = \frac{\text{Heat extracted in evaporator}}{\text{Work Input}}$$

$$\text{Co efficient of performance} = \frac{\text{Refrigerating Effect}}{\text{Work Input}}$$

$$\text{Co efficient of performance} = \text{NW}$$

The COP is always greater than 1 and known as theoretical coefficient of performance.

Applications of Refrigeration:

- In chemical industries, for separating and liquefying the gases.
- In manufacturing and storing ice.
- For the preservation of perishable food items in cold storages.
- For cooling water.
- For controlling humidity of air manufacture and heat treatment of steels.
- For chilling the oil to remove wax in oil refineries.
- For the preservation of tablets and medicines in pharmaceutical industries.
- For the preservation of blood tissues etc.,
- For comfort air conditioning the hospitals, theatres, etc.,

Properties of Refrigeration:

- A good refrigerant should have high latent heat of vapourisation.
- It should have low boiling and low freezing point.
- It should be non toxic and should non corrosiveness
- It should be non flammable and non explosive.
- It should have high thermal conductivity
- It should be easy to handle
- It should have low specific volume of vapour.
- It should have high co efficient of performance

5.2 VAPOUR COMPRESSION REFRIGERATION SYSTEM

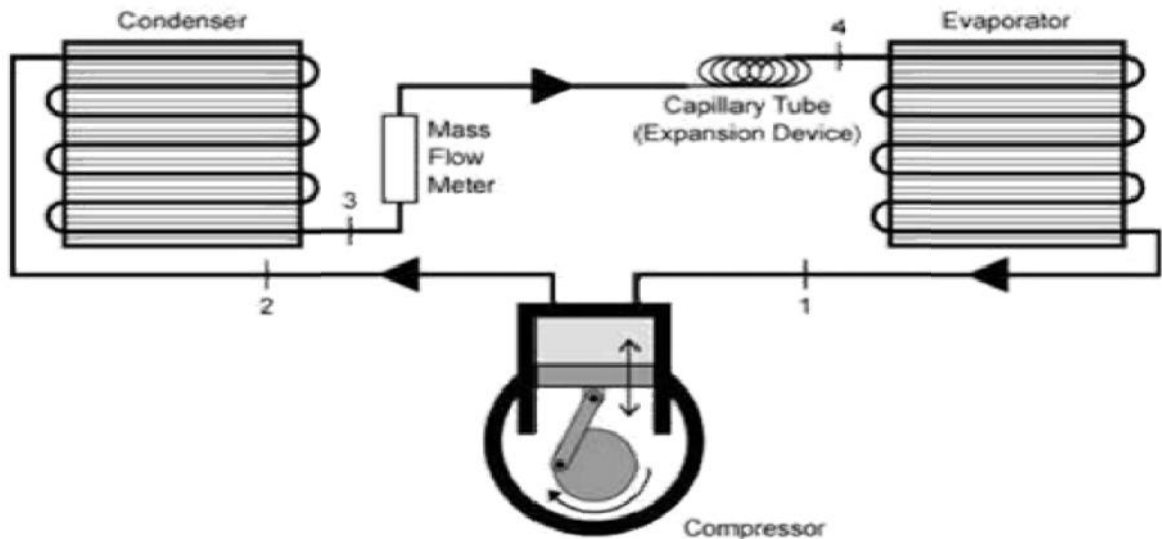

Construction:

This system consists of a compressor, condenser, a receiver tank, an expansion valve and an evaporator.

Compressor : Reciprocating compressors generally used. For very big plants centrifugal compressors directly coupled with high speed rotating engines (gas turbine) are used.

For very big plants Centrifugal compressors directly coupled with high speed rotating engines (gas turbine) are used

Condenser : It is a coil of tubes made of copper.

Receiver tank: It is the reservoir of liquid refrigerant.

Expansion Valve: This is a throttle valve. High pressure refrigerant is made to flow at a controlled rate through this valve.

Evaporator : It is the actual cooler and kept in the space to be cooled. The evaporator is a coil of tubes made of copper

5.3 VAPOUR ABSORPTION REFRIGERATION SYSTEM:

Construction:

The vapour absorption system consists of a condenser, an expansion valve and an evaporator.

They perform the same as they do in vapour compression method.

In addition to these, this system has an absorber, a heat exchanger, an analyser and a rectifier.

Working:

- Dry ammonia vapour at low pressure passes in to the absorber from the evaporator.
- In the absorber the dry ammonia vapour is dissolved in cold water and strong solution of ammonia is formed.
- Heat evolved during the absorption of ammonia is removed by circulating cold water through the coils kept in the absorber.
- The highly concentrated ammonia (known as Aqua Ammonia) is then pumped by a pump to generator through a heat exchanger.

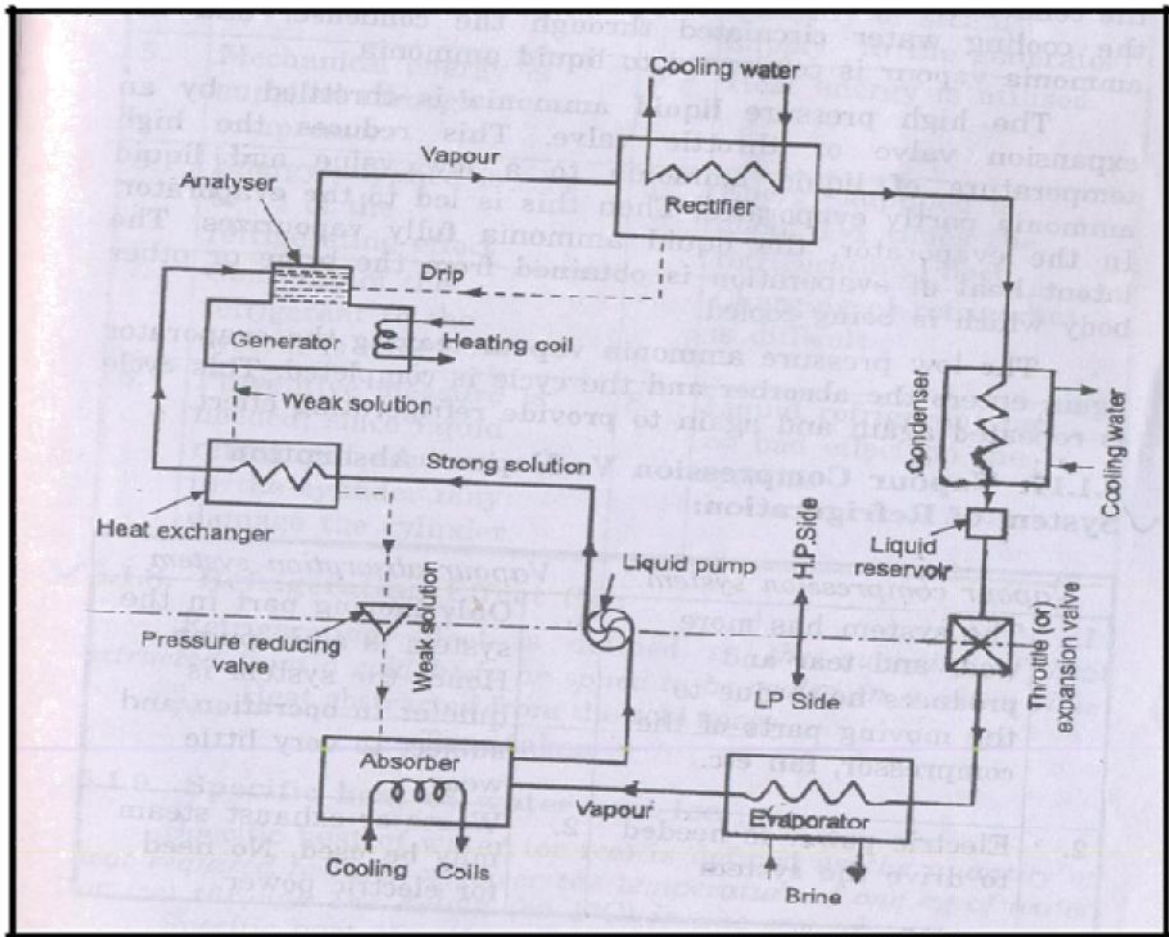

- In the heat exchanger the strong ammonia solution is heated by the hot weak solution returning from the generator to the absorber.
- In the generator the warm solution is further heated by steam coils, gas or electricity and the ammonia vapour is driven out of solution.
- The boiling point of ammonia is less than that of water.
- Hence the vapours leaving the generator are mainly of ammonia.
- The weak ammonia solution left in the generator is called weak aqua.
- This weak solution is returned to the absorber through the heat exchanger.
- Ammonia vapours leaving the generator may contain some water vapour.
- If this water vapour is allowed to the condenser and expansion valve, it may freeze resulting in choked flow.
- Analyser and rectifiers are incorporated in the system before condenser.
- The ammonia vapour from the generator passes through a series of trays in the analyser and ammonia is separated from water vapour.
- The separated water vapour returned to generator.
- Then the ammonia vapour passes through a rectifier.
- The rectifier resembles a condenser and water vapour still present in ammonia vapour condenses and the condensate is returned to analyser.
- The virtually pure ammonia vapour then passes through the condenser.
- The latent heat of ammonia vapour is rejected to the cooling water circulated through the condenser and the ammonia vapour is condensed to liquid ammonia.
- The high pressure liquid ammonia is throttled by an expansion valve or throttle valve.

- This reduces the high temperature of the liquid ammonia to a low value and liquid ammonia partly evaporates.
- Then this is led to the evaporator.
- In the evaporator the liquid fully vaporizes.
- The latent heat of evaporation is obtained from the brine or other body which is being cooled.
- The low pressure ammonia vapour leaving the evaporator again enters the absorber and the cycle is completed.
- This cycle is repeated again to provide the refrigerating effect.

Applications of refrigeration system:

- Preservation of food items like vegetables, milk and eggs.
- Preservation of medicines.
- Preservation of blood, tissues, etc.,
- Preservation and cooling of cool drinks.
- Preservation of chemicals (Chemical industries)
- Cooling of water.
- Industrial and comfort airconditioning.
- Processing of dairy products.

5.4 COMPARISON BETWEEN VAPOUR COMPRESSION & VAPOUR ABSORPTION REFRIGERATION SYSTEMS:

S.No.	Vapour Compression System	Vapour Absorption System
1.	This system has more wear and tear and produces more noise due to the moving parts of the compressor.	Only moving part in this system is an aqua pump. Hence the quieter in operation and less wear and tear
2.	Electric power is needed to drive the system	Waste of exhaust steam may be used. No need of electric power
3.	Capacity of the system drops rapidly with lowered evaporator pressure	Capacity of the system decreases with the lowered evaporative pressure, by increasing the steam pressure in generator.
4.	At partial loads performance is poor.	At partial loads performance is not affected.
5.	Mechanical energy is supplied through compressor	Heat energy is utilized
6.	Energy supplied is $\frac{1}{4}$ to $\frac{1}{2}$ of the refrigerating effect	Energy supplied is about one and half times the refrigerating effect
7.	Charging of the refrigerating to the system is easy	Charging of refrigerant is difficult
8.	Preventive measure is needed, since liquid refrigerant accumulated in the cylinder may damage to the cylinder	Liquid refrigerant has no bad effect on the system.

5.5 AIR CONDITIONING:

Air Conditioning is the process of conditioning the air according to the human comfort, irrespective of external conditions.

Applications of Air Conditioning

- Used in offices, hotels, buses, cars, etc.
- Used in industries having tool room machines.
- Used in textile industries to control moisture.
- Used in printing press.
- Used in Food industries, Chemical plants.

5.6 CLASSIFICATION OF AIR CONDITIONING:

Air conditioning systems are classified as

1) According to the purpose

- Comfort Air conditioning.
- Industrial Air conditioning.

2) According to Season of the year

- Summer Air conditioning.
- Winter Air conditioning.
- Year round Air conditioning.

Types of Air conditioners

- Room Air conditioners
- Winter Air conditioners
- Central Air conditioners

Functions of Air conditioners

- Cleaning air.
- Controlling the temp of air.
- Controlling the moisture content.
- Circulating the air.

BASIC CONCEPTS:

- Dry air: The atmospheric air which no water vapour is called dry air.
- Psychometry: Psychometry is the study of the properties of atmospheric air.
- 3) Temperature: The degree of hotness (or) Coldness is called the temperature.
- Moisture: Moisture is the water vapour present in the air.
- Relative humidity: Relative humidity is the ratio of actual mass of water vapour in a given volume to the mass of water vapour.
- Dry bulb temperature: The temperature of air measured by the ordinary thermometer is called dry bulb temperature:
- Wet bulb Temperature: The temperature of air measured by the thermometer when it is covered by the wet cloth is known as wet bulb Temperature.
- Dew point Temperature: The temperature at which the water vapour starts condensing is called dew point Temperature

5.7 WINDOW TYPE AIR CONDITIONER:

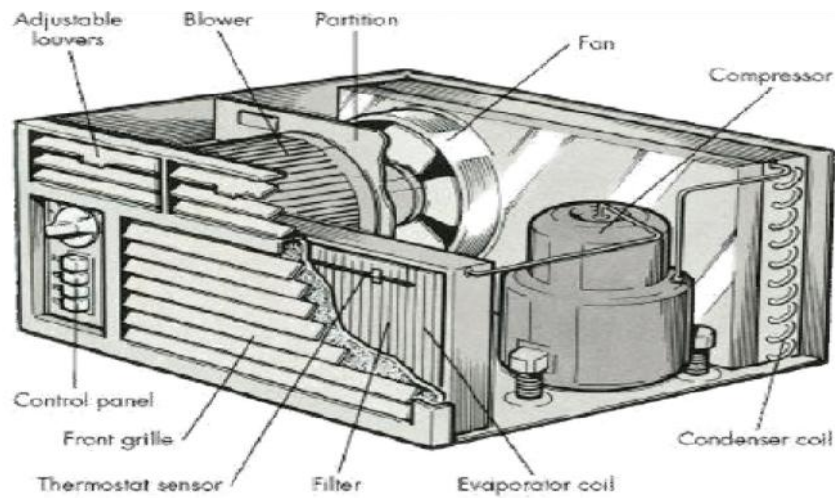
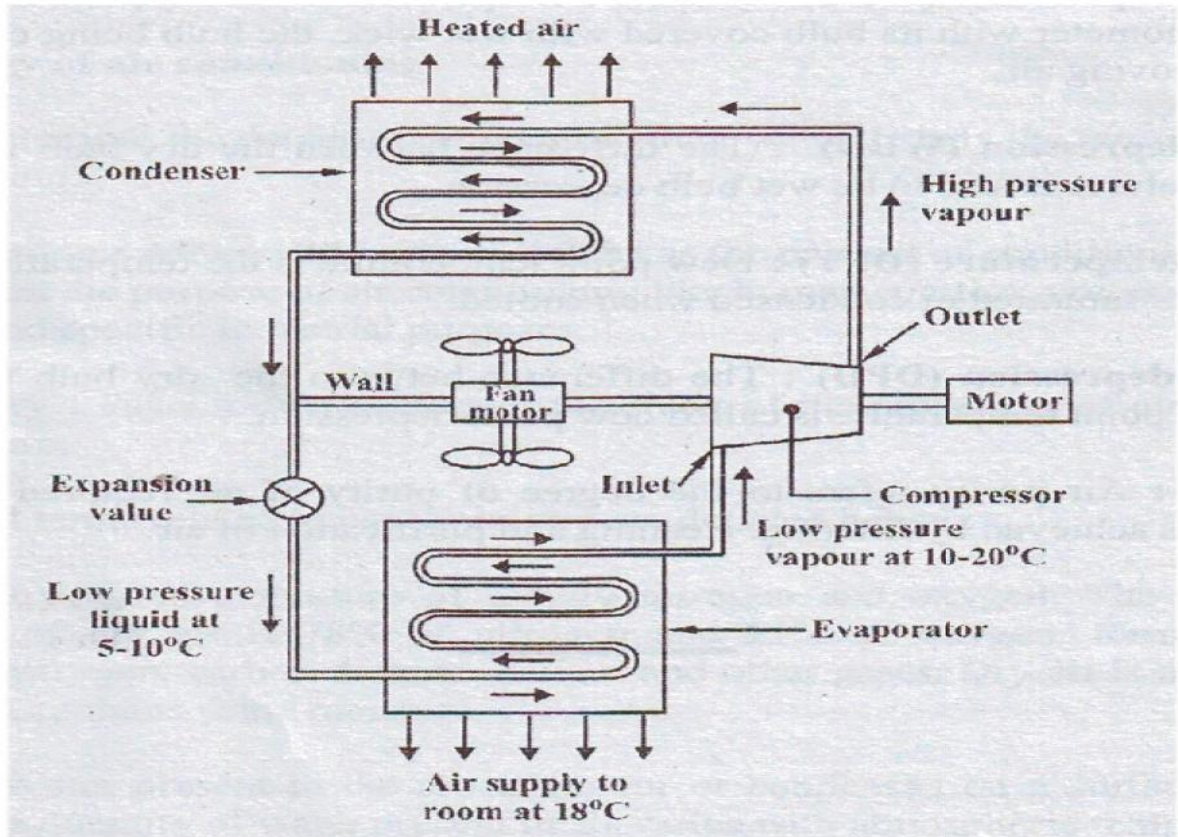

Construction:

This is also called room air conditioner.

This unit consists of the following.

- A cooling system to cool and dehumidify the air involves a condenser, a compressor and a refrigerant coil.
- A filter to any impurities in the air. The filter is made of mesh, glass wool or fibre.
- A fan and adjustable grills to circulate the air.
- Controls to regulate the equipment operation.
- The low pressure refrigerant vapour is drawn from the evaporator to the hermetic compressor through suction pipe.
- It is compressed from low pressure to the high pressure and supplied to the condenser.
- It is condensed in the condenser by passing the outdoor air over the condenser coil by a fan.
- The liquid refrigerant is passed through the capillary into the evaporator.
- . In the evaporator the liquid refrigerant picks up the heat from the refrigerator surface and gets vaporized.
- A motor driven fan draws air from the room through the air filter and this air is cooled by losing its heat to the low temperature refrigerant and cold air is circulated back into the room.
- The vapour refrigerant from the evaporator goes to the compressor from evaporator and the cycle is repeated.
- Thus the room is air conditioned
- The quantity of air circulated can be controlled by the dampers.
- The moisture in the air passing over the evaporator coil is dehumidified and drips into the trays.
- This water evaporator to certain extent and thus helps in cooling the compressor and condenser.
- The unit automatically stops when the required temperature is reached in the room. This is accomplished by the thermostat and control panel.

Merits and Demerits of Window type air conditioner:**Merits :**

A separate temperature control is provided in each room.

Ducts are not required for distribution.

Cost is less.

Skilled technician is required for installation.

Demerits:

It makes noise.

Large hole is made in the external wall or a large opening to be created in the window panel. This leads to insecurity to inmates.

Split Type Air Conditioner - Layout

- In split air type air conditioner noise making components like compressor and condenser are mounted outside or away from room.

- Split type air conditioning system has two main components.
- The indoor unit consists of power cables, refrigerant tube and an evaporator mounted inside the room.

Working:

- Compressor is used to compress the refrigerant.
- The refrigerant moves between the evaporator and condenser through the circuit of tubing and fins in the coils.
- The evaporator and condenser are usually made of coil of copper tubes and surrounded by aluminium fins.
- The liquid refrigerant coming from the condenser evaporates in the indoor evaporator coil.
- During this process the heat is removed from the indoor unit air and thus, the room is cooled.
- Air return grid takes in the indoor air.
- Water is dehumidified out of air is drained through the drain pipe.
- The hot refrigerant vapour is passed to the compressor and then to the condenser where it becomes liquid.
- Thus the cycle is repeated.
- A thermostat is used to keep the room at a constant, comfortable temperature avoiding the frequent turning on off.

Merits and Demerits of Split type air conditioner:

Merits :

- It is compact
- Upto four indoor AHU's may be connected to
- It is energy and money saving.
- Duct is not used.
- Easier to install.
- It is noiseless, because rotary air compressor used is, kept outside.
- It is more efficient and powerful.
- It has the flexibility for zoning.

DeMerits :

- Initial cost is higher than window air conditioner
- Skilled technician is required for installation.
- Each zone or room requires thermostat to control the air cooling.

Applications of air conditioning:

- Used in houses, hospitals, offices, computer centres, theatres, departmental stores etc.,
- Air-conditioning of transport media such as buses, cars trains, aeroplanes and ships.
- Wide application in food processing, printing, chemical, pharmaceutical and machine tool, etc.,

**UNIT I
QUESTION BANK**

1. What is surveying?
2. what is the objective of surveying?
3. what is the difference between a plan and a map?
4. what are the two major types of surveying
5. Differentiate between plane surveying and geodetic surveying?
6. How the surveying is classified based on purpose
7. State the principles of surveying.
8. What are the accessories used in chain surveying?
9. Define bearing of a line.
10. What are the systems of bearing
11. What is meant by local attraction & state its effects?
12. Define leveling and state its objectives
13. Define benchmark and state its effects
14. How rocks are classified?
15. What is quarrying & dressing of stones
16. What are the uses of stones?
17. State the uses of cement?
18. State the properties of cement concrete.
19. What is proportioning of concrete?
20. Define workability of concrete.

PART-B (16 Marks)

1. Explain with neat sketch prismatic compass and principles of compass surveying.
2. Explain with neat sketch 20m chain and principles of chain surveying.
3. The following staff readings were observed successively with level, the instrument having been shifted after second and fifth readings
0.870; 1.635; 2.135; 1.280; 2.980
3.125; 0.120; 1.825; 2.765; 2.015
the first reading was taken with the staff held upon a bench mark of elevation + 100.00. Enter the readings in level book and final reduced levels. Apply the usual checks. Find also the difference in level between the first and last
4. What are the requirements of good building stone & state important varieties of Building stones
- 5 The following perpendicular offset were taken at 10 meter intervals from an
Survey line to an irregular boundary line
3.145m, 4.30m, 8.20m, 5.60m, 7.60m, 4.2m, 5.6m, 4.3m.
Calculate the area enclosed between the survey line, the irregular boundary line, and first and last offsets by the application of
a) Average ordinate method b) Trapezoidal rule and c) Simpson’s rule
6. What are the different types of cement? Explain the properties and uses?
7. What are the different types of steel? Explain the properties and uses?

UNIT II

1. State the objectives and requirements of good foundation?
2. Differentiate between shallow foundation and deep foundation.
3. Define bearing capacity of soil.
4. How the stone masonry is classified?
5. Define the following terms.
 - i) Corbel
 - ii) Cornice
 - iii) Coping
 - iv) String course
 - v) Through stone
6. Compare stone masonry and Brick masonry
7. Why bonding in brick wall is essential?
8. State the special features of English and Flemish bond.
9. Define beam, column and Lintel.
10. Classify the types of column based on its conditions.
11. State the purpose of plastering.
12. Define Dam, Bridge and classify them
13. What are the basic components of a bridge?
14. What is the purpose of reinforced concrete?
15. Define factor of safety.

PART-B (16 Marks)

1. a. List the six important points to be considered while selecting a site for Construction of Dam.
b. Explain differential leveling with a neat sketch.
2. Explain with neat sketch the different types of piles.
3. List out the different types of bond in brick wall and explain any three in detail.
4. Draw a neat sketch of a reinforced cement concrete column and explain.
5. Explain the types of floor suitable for residential and commercial building.
6. Explain briefly the different types of pitched roof coverings.

QUESTION BANK
UNIT –III (POWER PLANT ENGINEERING)

PART –A (2 MARKS)

1. What are the types of power plant?
2. What are the parts of thermal power plant?
3. What is the purpose of Surge tank in hydro power plant?
4. Classify the hydro power plant.
5. What is the function of Draft tube?
6. Define Nuclear Fission. Write chain reaction.
7. What is the function of Moderator?
8. Write down the Merits and Demerits of Diesel engine power plant.
9. List out the parts of the Gas turbine power plant.
10. Define Pump and Turbine.
11. Define Cavitations.
12. Define Primiming in Centrifugal Pump.
13. What is impulse turbine? Give example
14. What is Reaction turbine? Give example.
15. What does the study of power plant engineering include?
16. Define the term: Prime mover.
17. Define power plant.
18. What are the different types of power plants?
19. Give the function of condenser in steam power plant.
20. What is the function of moderator in a nuclear power plant?
21. Give four important factors to be considered for selecting hydroelectric power plant.
22. Mention the reason for preferring steam power plant to other power plants.
23. What is the cooling tower? Give its uses.
24. What are the nuclear fuels used in the nuclear reactor?
25. What is the function of penstock pipe?
26. What is meant by nuclear fission?
27. What is the function of intercooler in gas turbine power plant?
28. Name the different components of a gas turbine power plant.
29. Briefly explain what radiation shielding means?
30. What are the different types of hydro power plants?
31. State the disadvantages of steam power plant.
32. Mention the applications of gas turbine power plant.
33. What are the different types of wind mills?
34. State the advantages of tidal power plant.
35. Define steam turbine.
36. State the main parts of a steam turbine.
37. How steam turbines are classified?
38. Give an example for reaction turbine.
39. State the limitations of impulse turbine.
40. What is the difference between impulse and reaction turbine?
41. Relative velocity of steam increases in reaction turbine. Give reason.

PART –B (10 MARKS)

1. Explain the working principle of thermal power plant with neat sketch.
2. Explain the working principle of steam power plant with neat sketch.
3. Explain working principle of Nuclear Power plant with neat sketch.
4. a) Explain working principle of Hydro Electric Power plant with neat sketch.
b) Write its advantages and Disadvantages
5. a) Explain working principle of Diesel Engine Power plant with neat sketch.
b) Write its advantages and Disadvantages.
6. a) Explain working principle of Gas turbine Power plant with neat sketch.
b) Write its advantages and Disadvantages.
7. With the help of a neat sketch explain the working of Reciprocating Pump
8. a) With the help of a neat sketch explain the working of Centrifugal Pump
b) With the help of a neat sketch explain the working of Impulse Turbine
9. What are the applications of Diesel power plants?
10. State the advantages and disadvantages of a gas turbine plant.
11. State the advantages and disadvantages of hydroelectric power plant compared to thermal and nuclear power plants.
12. With the aid of a general layout, explain the working of different circuits of a thermal power plant.
13. Sketch and describe the schematic arrangement of a modern steam power station and detail the various heat saving devices used.
14. Give a schematic layout of a storage type hydro-electric power plant and explain the function of each component of the plant.

UNIT –IV (INTERNAL COMBUSTION ENGINES)**PART –A (2 MARKS)**

1. What is heat engine?
2. Define I.C Engine and E.C. Engine
3. Classify the I.C engine.
4. List out the Part of the I.C. Engine
5. Define the terms: Top Dead Center, Bottom Dead Center.
6. Define the term: Compression Ratio.
7. What do you understand by Scavenging?
8. Define Boiler.
9. Classify Boilers.
10. Define fire tube boiler and water tube boiler.
11. List out the Boiler Mountings and Accessories.
12. What is the Purpose of a fusible Plug?
13. What is an engine?
14. What are the types of heat engine?
15. What is meant by S.I engine? Why is it called so?
16. What is meant by C.I engine? Why is it called so?
17. Give the main components of a petrol engine.
18. What is a four stroke engine?
19. What is the function of a carburettor?
20. What is the fundamental difference between two-stroke and four- stroke engine?
21. Why fuel is injected in a C.I. engine?

22. Define - Carburettor.
23. Mention the types of ignition systems used in petrol engine.
24. State the function of a choke in a petrol engine.
25. What is the function of a spark plug?
26. Define fuel injector.
27. What are the types of cooling systems used in I.C. engine?
28. Mention the types of water cooling on I.C. engine?
29. Define lubrication.
30. Mention some engine parts that require frequent lubrication.
31. What are the types of lubricating an I.C. engine?
32. How boilers are classified?
33. Mention the advantages of high pressure boilers.
34. State the main function of a boiler.
35. How modern boilers differ from olden day boilers? Give four important points.
36. What is the use of an economizer in a high pressure boiler?
37. What is the difference between mountings and accessories in a boiler?
38. Name any two mountings of a boiler.
39. What is a boiler?
40. State the main components of a boiler.
41. What is the use of super heater in a high-pressure boiler?
42. Name any two steam boiler accessories.
43. What do you understand by forced circulation boiler?
44. State different types of safety valves in a boiler.
45. State the function of a Air preheater.
46. Give an example for a water tube boiler.
47. Define the terms: External Combustion Engine and Internal Combustion engine.
48. Define compression ratio of an I.C. engine.
49. What is the function of deflector in a two stroke engine?
50. What is the function of a choke in a carburettor?
51. What is meant by carburetion?
52. What is the function of the float, float chamber and needle valve assembly in a single jet carburettor?
53. State any two limitations of a single jet carburettor.
54. How do you provide an extra-rich mixture to the petrol engine during starting in cold weather?
55. Name the three ports provided at the cylinder walls in a two stroke engine function.
56. Why is diesel engine called as compression ignition engine?
57. How do the three ports in a two stroke engine function?
58. What is the function of a spark plug?
59. State any two advantages of LPG as SI engine fuel.

PART –B (10 MARKS)

1. Describe the principal parts and functions of a Four Stroke Diesel engine with neat sketch.
2. What is heat engine? How do you classify heat engines?
3. What do you understand by scavenging?
4. Compare and contrast four stroke engines with two stroke engines?
5. Discuss briefly the ignition system of SI engine.

6. Explain the working principle of spark plug with a neat diagram.
7. Sketch and explain the working of a Diesel fuel pump.
8. Explain the working principle of Diesel engine power plant with neat sketch. Also give its advantages and disadvantages.
9. Describe the principal parts and functions of a Four Stroke Petrol engine with neat sketch.
10. Describe the principal parts and functions of a Two Stroke Diesel engine with neat sketch.
11. Describe the principal parts and functions of a Two Stroke Petrol engine with neat sketch.
12. Describe the principal parts and functions of any one high pressure boiler with neat sketch.
47. Describe the principal parts and functions of Babcock Wilcox boiler with neat sketch.
Explain the construction and working principle of Cochran Boiler

UNIT –V (REFRIGERATION AND AIR CONDITIONING SYSTEM)
PART –A (2 MARKS)

1. Define Refrigeration.
2. Mention the ways of achieving refrigeration effect.
3. Mention some of the applications of refrigeration
4. Define the term refrigeration effect.
5. What is the meaning of “one tonne of refrigeration?”
6. How the capacity of the refrigeration system specified?
7. Define the term “Coefficient of performance”?
8. Classify the refrigerating system.
9. What is the function of compressor in refrigerating system?
10. What is the function of condenser in refrigerating system?
11. What is Evaporator?
12. Mention any three desirable properties of good refrigerant.
13. List the properties of absorbent.
14. What is the function of the Absorber in Vapour –Absorption refrigerator?
15. Mention the advantages of Absorption refrigeration system over compression refrigeration system.
16. What are primary refrigerants?
17. List some important refrigerants.
18. Why Ammonia is preferred in absorption system?
19. What is the technical name of Freon-12?
20. What are the properties of Freon-12?
21. Write short notes on compressors.
22. What are the types of compressors?
23. Define C.O.P.
24. Define refrigerant. Give some examples of refrigerant.
25. Give some properties of good refrigerant.
26. Mention the types of refrigerators.
27. Give some properties of a good refrigerant.
28. State the function of a compressor.
29. Define relative humidity
30. Define psychrometry.
31. What is dry air?
32. What is moist air?

33. Define the term absolute humidity.
34. Define the term Dry bulb temperature.
35. Define the term Wet bulb temperature.
36. What is called Wet bulb depression?
37. Define the term Dew point temperature.
38. What is the use of Psychrometric chart?
39. Define DBT and WBT.
40. Define humidity.
41. Define air conditioning.
42. What are the control systems used in domestic refrigerators?
43. Mention the classification of air conditioning system.
44. Define year-round air conditioning system.
45. What is the function of thermostat?
46. What is called defrosting?
47. Mention the loads encountered in air conditioning systems.
48. What is window air conditioner?
49. What are the limitations of Window air conditioners?
50. What are the requirements of comfort air conditioning?

PART –B (10 MARKS)

1. Explain the principle and working of vapour compression refrigeration system.
2. Explain the principle and working of the vapour absorption refrigeration system.
3. Give the comparison of vapour absorption with vapour compression refrigeration system.
4. How do you classify the air conditioning system?
5. Explain the summer air-conditioning system for hot and dry weather.
6. With the neat sketch explain the layout of a window room air conditioning.
7. Explain the layout of the split type air conditioning system.
8. Mention and explain the different types of refrigerant used.
9. Explain the advantages and disadvantages of the window air conditioning unit.
10. State the principle of air conditioning. What are the parameters required for the human comfort in air conditioning?
11. Discuss the advantages and disadvantages of split type room air conditioner

Question Paper Code: 1662141
B.E./B.Tech. DEGREE EXAMINATIONS, NOV./DEC. 2011
Regulations 2008

Second Semester

Common to EEE, E & I, I & C, ECE, CSE, IT and Bio Medical
Engineering branches

GE2152 Basic Civil and Mechanical Engineering

Time: Three Hours Maximum: 100 marks

Answer ALL Questions

Part A - (10 x 2 = 20 marks)

1. Write *the* arithmetic equation used in rise and fall method of levelling.
2. Define 'mortar' which is used in construction works.
3. What is a foundation (for building)?
4. What is meant by plastering?
5. Write any two purposes of a dam.
6. State two merits and two demerits of a Nuclear power plant.
7. What is the use of draft tube in hydraulic turbines?
8. What is a heat engine?
9. Mention any four boiler mountings.
10. What is refrigeration? Name any two common refrigerants used in refrigerators.

Part B - (5 x 16 = 80 marks)

11. (a) (i) List out *the* differences between height of collimation method and rise and fall method of leveling. (6)

(ii) A survey was conducted on a plot which is having a triangular shape in which *the* length of side AB is 200 m and *the* bearings of sides AC, AB and BC are 65°, 160°, and 20° respectively. Find out *the* area of the plot.

(10)

OR

11. (b) (i) Explain *the* steps involved in the manufacture of bricks. (8)
- (ii) Sketch any four steel sections that are commonly used in civil engineering.
12. (a) (i) State *the* various functions of a foundation for a building. (4)
- (ii) Explain briefly the following types of shallow foundations with appropriate sketches:
 - (1) Isolated column footings (4)
 - (2) Combined column footings (4)
 - (3) Grillage foundation (4)

OR

12. (b) (i) A steel rod of 20 mm diameter of 1 m long is subjected to an axial pull of 50 kN. Determine *the* stress, strain and elongation of the rod. Take Young's modulus as $E = 2 \times 10^5 \text{ N/mm}^2$. (7)
- (ii) Sketch *the* following types of Dams:
 - (1) Rock-fill Dam
 - (2) Gravity Dam

(3) Arch Dam Add one or two sentences of explanation. (9)

13. (a) (i) With reference to gas turbine power plant, explain, with suitable sketches, *the* working of the following:

(1) Open cycle gas turbine plant (6)

(1) Closed cycle gas turbine plant (6)

(ii) List *the* merits of a gas turbine power plant. (4)

OR

13. (b) (i) With a neat schematic diagram, explain the working principle of a double acting reciprocating pump. State why it is called double acting pump.(10)

(ii) What is cavitation in pumps? Explain. (6)

14. (a) What are *the* four strokes of a four-stroke petrol engine? Explain each of them with separate sketches. (16)

OR

14. (b) (i) State *the* various differences between fire tube boiler and water tube boiler.(8)

(ii) Draw a neat sketch of a simple fire tube boiler and explain its working in detail. (8)

15. (a) With the help *of* a neat schematic diagram, explain the working principle *of* a vapor absorption refrigeration system. (16)

OR

15. (b) (i) Draw *the* layout of a split air-conditioning unit and explain its working; also state how are the arrangement *of* its components is different from that of a window air-conditioner. (13)

(ii) What are *the* advantages of split air-conditioner compared to a window air-conditioner?

B.E./B.Tech. DEGREE EXAMINATION, JUNE 2010**Second Semester****Electrical and Electronics Engineering****GE2152 - BASIC CIVIL AND MECHANICAL ENGINEERING****(Regulation 2008)**

(Common to Bio-medical Engineering, Electronics and Communication Engineering,
Electronics and Instrumentation Engineering, Information Technology, Computer
Science and Engineering, Instrumentation and Control Engineering)

Time: Three hours Maximum: 100 Marks

Answer ALL Questions**PART A- (10 x 2 =20 Marks)**

1. State the two principles of surveying.
2. How are bricks classified?
3. Define bearing capacity of soil.
4. Define stress and strain.
5. What is the use of surge tank in hydropower plants?
6. Give two examples for positive displacement pumps.
7. What is the function of a carburetor?
8. Compare two stroke and four stroke engines with regard to power output and thermal efficiency, for the same speed and cylinder capacity.
9. Define Ton of Refrigeration.
10. State the values of DBT and RH for human comfort in India.

PART B - (5 x 16 =80 Marks)

11. (a) The following perpendicular offsets were taken at 10 m intervals from a survey line to an irregular boundary line: 3.15 m, 4.30 m, 8.20 m, 6.85 m, 7.60 m, 4.20 m, 5.60 m, and 4.30 m. Calculate the area enclosed between the survey line, irregular boundary line, first and last offsets by trapezoidal rule.

Or

- (b) What are the different types of cement? Explain their properties and uses.

Or

12. (a) Describe with neat sketches:
 - (i) Any one type of shallow foundation
 - (ii) Pile foundation.
 - (b) Describe with neat sketches
 - (i) Arch culvert
 - (ii) T-Beam and Slab Bridge.
 13. (a) Draw a neat Layout of a typical Steam Power Plant and explain the various circuits involved.
- Or
- (b) With the help of suitable sketches, explain the working of a Reciprocating Pump. What are the advantages of centrifugal pumps over reciprocating pumps?
 14. (a) Explain the working of a two stroke Petrol engine. What are the merits and demerits of two stroke engines?

Or

(b) Explain the- principle of working of a four stroke Diesel engine with suitable sketches. What are the merits and demerits of four stroke engines?

15. (a) With the help of flow diagram explain the principle of working of a vapour compression refrigeration system. Compare vapour absorption refrigeration with vapour compression refrigeration.

Or

(b) With a neat sketch, explain in detail the working of a window type room air conditioner.

Question Paper Code: U4008

B.E./B.Tech. DEGREE EXAMINATION, NOVEMBER/DECEMBER 2009

Second Semester

Electronics and Communication Engineering

GE 2152 - BASIC CIVIL AND MECHANICAL ENGINEERING

(Common to Biomedical Engineering, Electrical and Electronics Engineering,
Electronics and Instrumentation Engineering, Information Technology, Computer
Science and Engineering and Instrumentation and Control Engineering)

(Regulation 2008)

Time: Three hours Maximum: 100 Marks

Answer ALL Questions

PART A- (10 x 2 = 20 Marks)

1. What is the principle of surveying?
2. Differentiate WCB from RB.
3. Define safe bearing capacity of soil.
4. What is Poisson's ratio?
5. List the types of dams.
6. Give the classification of power plants.
7. What is the principle of centrifugal pump?
8. What is meant by two stroke cycle engine?
9. Define the term refrigeration.
10. Mention the applications of refrigeration.

PART B - (5 x 16 = 80 Marks)

11. (a) (i) Draw a neat sketch of a dumpy level and indicate its parts. (8)
(ii) Explain how reciprocal levelling is carried out in case of obstruction. (8)

Or

- (b) (i) What are the requirements of a good building stone? (5)
(ii) What is the chemical composition of cement? (5)
(iii) List the types of cement and the various tests carried out on ordinary Portland cement. (6)
12. (a) Enumerate different types of foundations you would recommend under different situations and soil conditions. Explain them briefly. (16)
Or
(b) Draw a typical vertical section of a wall through openings, and show various important elements of construction. (16)
13. (a) Explain the working of a single acting single stage reciprocating pump with a neat sketch. Name the main parts. (16)

Or

(b) Explain the construction and working of a centrifugal pump with a neat sketch. (16)

14. (a) Describe the working of four stroke cycle petrol engine with neat sketches. (16)

Or

(b) Compare two-stroke engine with four-stroke engine. (16)

15. (a) Explain with a line diagram the construction and working of a vapour compression system of refrigeration. (16)

Or

(b) How are vapour refrigerators classified? Explain their operation. Mention the names of vapours used in vapour refrigerators. (16)

Reg. No. :

--	--	--	--	--	--	--	--	--	--	--	--	--	--	--	--	--	--	--	--

Question Paper Code : 11434

B.E./B.Tech. DEGREE EXAMINATION, NOVEMBER/DECEMBER 2012.

Second Semester

Electrical and Electronics Engineering

GE 2152/185204/ME 26/10111 CE 206/081510002/GE 1151 A — BASIC CIVIL AND MECHANICAL ENGINEERING

(Common to Electronics and Communication Engineering, Electronics and Instrumentation Engineering, Biomedical Engineering and Medical Electronics Engineering, Instrumentation and Control Engineering, Computer Science and Engineering and Information Technology)

(Regulation 2008)

Time : Three hours

Maximum : 100 marks

Answer ALL questions.

PART A — (10 × 2 = 20 marks)

1. Write the arithmetic equation used in rise and fall method of levelling.
2. Name any two properties of good cement.
3. What is a foundation (for building)?
4. What are the types of flooring used in residential building?
5. Sketch a pictorial view of a rectangular block subjected to a shear force and indicate shear area. Hence, state what is a shear stress?
6. State the advantages of thermal power plant over hydro electric power plant.
7. What are the effects of cavitation in centrifugal pump?
8. What are the main components of an I.C. engine?
9. What is the purpose of lubrication in an IC engine?
10. State the role of condenser in vapor compression refrigeration cycles.

PART B — (5 × 16 = 80 marks)

11. (a) (i) Name any four classifications of surveying based on the instruments used. (4)
(ii) The leveling work is carried out in the field and the measured levels are given below. Calculate the reduced levels of points. Use height of collimation method. The reduced level of last point is 200 m. (12)

Instrument station	Staff station	B.S.	I.S.	F.S.
P	A	2.380	-	-
	B	-	0.865	-
	C	-	1.380	-
	D	-	1.965	-
Q	E	1.465	-	2.850
	F	-	2.495	-
	G	-	1.560	-
	H	-	1.845	-
	I	-	0.625	-
	J	-	-	-

Make usual arithmetic check.

Or

- (b) (i) What are the sources of sand? State the properties of good sand. What are functions of sand in mortar? (8)
- (ii) Sketch any four steel sections that are commonly used in civil engineering. (8)
12. (a) (i) Define Bearing capacity of soils and give the methods of improving the bearing capacity. (6)
- (ii) State the various functions of a foundation for a building. (4)
- (iii) When do we use deep foundations? With the help of suitable sketches, distinguish between bearing pile foundation and friction pile foundation. (6)

Or

- (b) (i) A 200 kN compressive load was applied on cylindrical specimen of 30 mm diameter and 200 mm length. The decrease in the length of specimen was observed as 0.4 mm. Find out the stress, strain and Young's modulus of the material. (5)
- (ii) What is a bridge? What are meant by 'superstructure' and 'substructure' of a bridge? (3)
- (iii) Sketch a line diagram showing the top view of a bridge and state what are 'Piers', 'Abutments', 'Wing walls' and 'Clear span' of a bridge. (3)
13. (a) (i) Draw the layout of a Diesel Power Plant. State the subsystems and components of the plant and explain each one of them briefly. (12)
- (ii) State the advantages and disadvantages of diesel power plant. (4)

Or

- (b) (i) State the basic principle of working of a reciprocating pump. (2)
- (ii) With the help of a neat sketch of a single acting reciprocating pump, name the various components and explain its working. (10)
- (iii) What is the difference between single acting and double acting reciprocating pumps? (4)
14. (a) (i) What is the difference between internal combustion engines and external combustion engines? Give an example for each type. (4)
- (ii) With the help of a diagram, define the parameters: Bore, Stroke, TDC, BDC, Clearance volume, Swept volume and Compression ratio of an internal combustion engine. (12)

Or

- (b) Explain the working of a two-stroke petrol engine, with sketches for the following events:
- (i) End of compression
- (ii) Beginning of exhaust
- (iii) Beginning of 'transfer of charge' into the cylinder
- (iv) Start of compression (16)
15. (a) With the help of a neat schematic diagram, explain the working principle of a vapor absorption refrigeration system. (16)

Or

- (b) Draw the layout diagram of a typical domestic refrigerator and explain the working of its various components. (16)

PART B — (5 × 16 = 80 marks)

11. (a) (i) Explain with a neat sketch prismatic compass surveying. (12)
(ii) What are the various types of bricks based on quality? (4)

Or

- (b) State the properties and uses of Sand, Cement, concrete and Steel sections. (16)

12. (a) Draw the following bridges and name their parts

- (i) Reinforced concrete slab culvert. (4)
(ii) Pre-stressed concrete bridge. (4)
(iii) Discuss briefly about the Internal and External forces on Superstructure. (8)

Or

- (b) Convert the following Whole Circle Bearing into Reduced Bearing : (16)

- (i) $66^{\circ} 30'$ (ii) $130^{\circ} 15'$
(iii) $205^{\circ} 30'$ (iv) $265^{\circ} 10'$
(v) $295^{\circ} 30'$ (vi) $320^{\circ} 15'$

13. (a) Draw and name the parts of a Centrifugal Pump and explain its working. (16)

Or

- (b) (i) Draw a sketch of a single acting reciprocating pump. (8)
(ii) List the components and briefly explain their functions. (8)

14. (a) (i) Explain the forced - circulation water cooling system in I.C engine. (10)
(ii) List out the advantages of petrol lubrication system. (4)
(iii) Define : Compression ratio. (2)

Or

- (b) (i) Write in detail about the working principle of two stroke cycle Engine. (8)
(ii) Briefly discuss – Boiler as a power point. (8)

15. (a) Draw the sketch of vapour absorption refrigeration system and list out the components and their functions. (16)

Or

- (b) Write short notes on Window and split air conditioner. (16)

Reg. No.:

--	--	--	--	--	--	--	--	--	--	--	--	--	--	--	--	--	--	--	--

Question Paper Code : 21468

B.E./B.Tech. DEGREE EXAMINATION, MAY/JUNE 2013.

Second Semester

Electrical and Electronics Engineering

GE 2152/ME 26/GE 1151 A/10111 CE 206/080510002 — BASIC CIVIL AND
MECHANICAL ENGINEERING

(Common to Electronics and Communication Engineering, Biomedical Engineering,
Computer Science and Engineering, Electronics and Instrumentation Engineering,
Instrumentation and Control Engineering and Information Technology)

(Regulation 2008/2010)

Time : Three hours

Maximum : 100 marks

Answer ALL questions.

PART A — (10 × 2 = 20 marks)

1. What are the objectives of surveying?
2. What is the advantage of reinforced concrete compared to plain concrete?
3. What is a mud plaster?
4. What is a deep foundation?
5. What is the advantage of buttress dam compared to solid gravity dam?
6. What are the main components of gas turbine power plant?
7. Mention the purpose of moderator in a nuclear reactor.
8. What are the functions of fuel injection pump in a Diesel engine?
9. Calculate the number of sparks per minute produced by the spark plug of a four-stroke single cylinder petrol engine running at 3000 rpm.
10. Define Ton of refrigeration.

PART B — (5 × 16 = 80 marks)

11. (a) Classify surveying based on the instruments used. Discuss any two methods in detail.

Or

- (b) Discuss qualities and uses of any three building materials.

12. (a) Discuss in detail about the foundation for machinery.

Or

- (b) (i) Explain various kinds of rubble masonry with sketches. (8)

- (ii) Write short notes on columns. (8)

13. (a) (i) Write briefly about the types of floorings. (6)

- (ii) What are the factors to be considered and data to be collected before constructing a bridge? (10)

Or

- (b) (i) Draw the layout of thermal power plant and indicate various systems in it. (10)

- (ii) Write briefly the principle of working of single acting reciprocating pump. (6)

14. (a) With relevant sketches explain the operation of four stroke petrol engine.

Or

- (b) (i) Write briefly about the fuel supply systems used in SI engines. (10)

- (ii) Compare two stroke and four stroke engines. (6)

15. (a) Explain the operation of any one type of refrigeration system with the schematic line diagram.

Or

- (b) Explain Window Air-Conditioner with a neat diagram.

Reg. No. :

--	--	--	--	--	--	--	--	--	--	--	--	--	--	--	--	--	--	--	--

Question Paper Code : 57021

B.E./B.Tech. DEGREE EXAMINATION, MAY/JUNE 2014.

Second Semester

Electrical and Electronics Engineering

GE 6251 — BASIC CIVIL AND MECHANICAL ENGINEERING

**(Common to Electronics and Instrumentation Engineering,
Instrumentation and Control Engineering)**

(Regulation 2013)

Time : Three hours

Maximum : 100 marks

Answer ALL questions.

PART A — (10 × 2 = 20 marks)

1. Name the few types of cements used in construction.
2. What is meant by surveying?
3. State the purpose of dams.
4. List the different types of bonds in brick masonry.
5. How turbines are classified?
6. Mention any four types of power plants.
7. State any five differences between two stroke and four stroke cycle engine.
8. List the important parts of diesel engine power plant.
9. What are factors which affect the comfort air-conditioning?
10. Define tonne of refrigeration.

PART B — (5 × 16 = 80 marks)

11. (a) Describe the different types of Concrete.

Or

(b) Classify bricks and state its characteristics and uses of each one of them.

12. (a) What do you understand by a foundations? Draw sketches to show various types of shallow foundations.

Or

(b) What are the factors influencing the selection of dams. Explain with neat diagram any one type of dam.

13. (a) Explain with a neat sketch of Thermal (steam) power plant.

Or

(b) Explain the working principle of a single acting reciprocating pump with help of a line sketch.

14. (a) Explain the working principle of four stroke cycle diesel engine with neat sketch.

Or

(b) Discuss the working of two stroke cycle petrol engine with help of neat sketch.

15. (a) Explain the Domestic Refrigerator with neat sketch.

Or

(b) Explain the vapour compression refrigeration system with neat sketch. Compare it with absorption system.