



SNS COLLEGE OF ENGINEERING

Kurumbapalayam (Po), Coimbatore – 641 107

An Autonomous Institution

Accredited by NBA – AICTE and Accredited by NAAC – UGC with 'A' Grade

Approved by AICTE, New Delhi & Affiliated to Anna University, Chennai

DEPARTMENT OF ELECTRICAL AND ELECTRONICS ENGINEERING

COURSE NAME : 19EC309 ELECTRICAL MACHINES AND POWER SYSTEMS

II YEAR / 03 SEMESTER MECH & MCT

Unit 4 – SPECIAL MACHINES

Stepper Motors



Stepper Motor

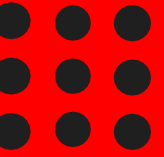

Stator



Rotor



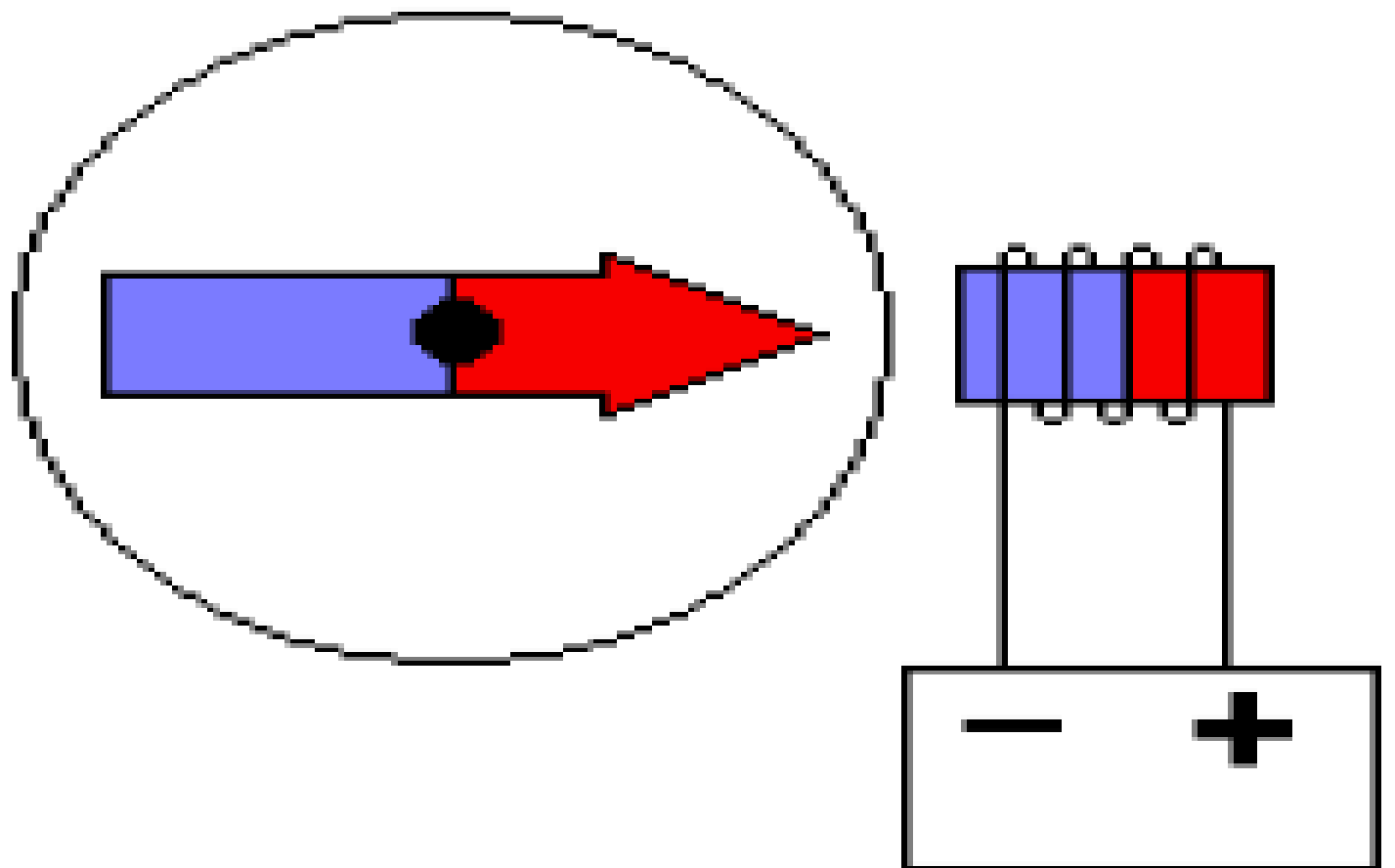
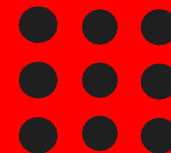

DC Power



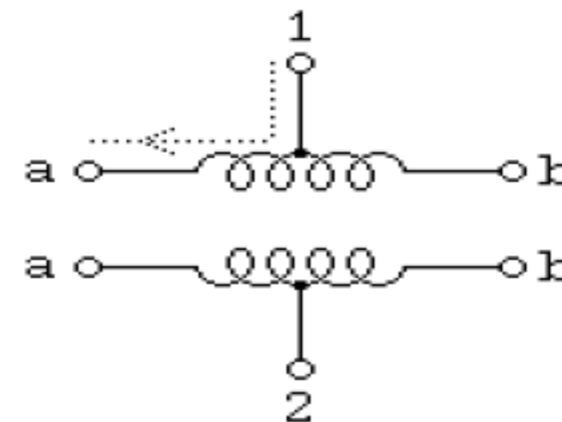
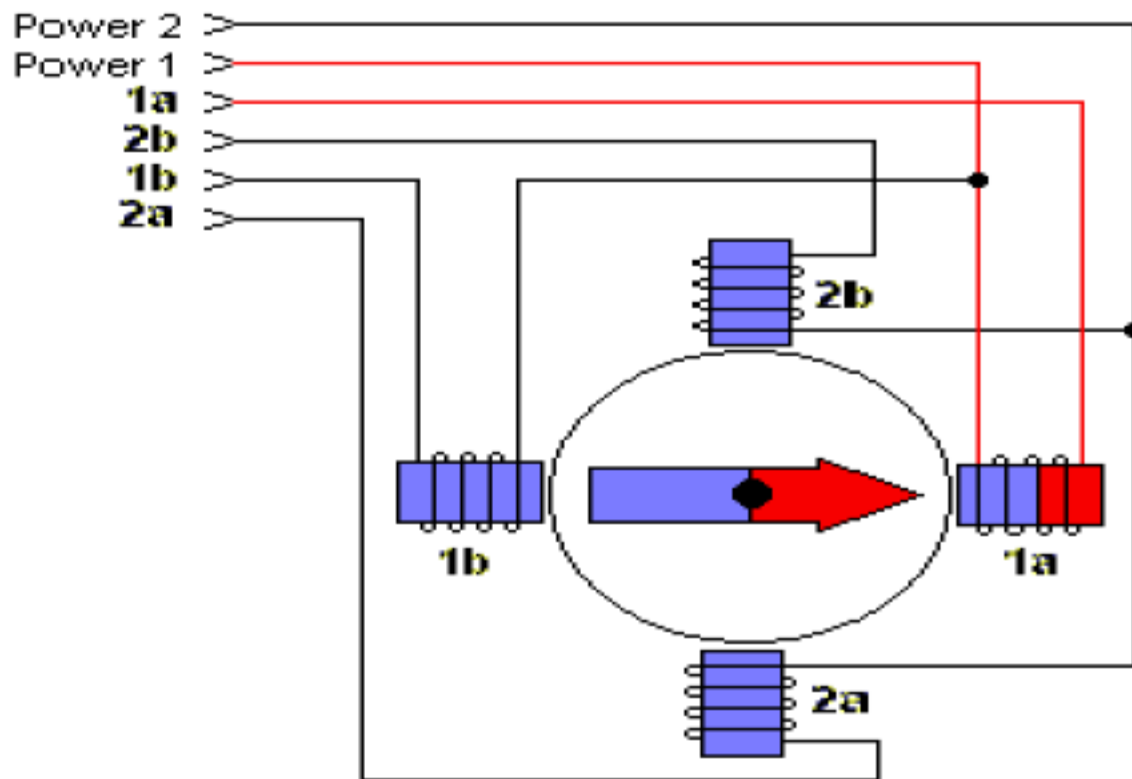
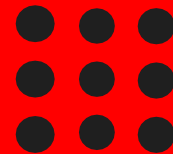

Conceptual Model of Unipolar Stepper Motor



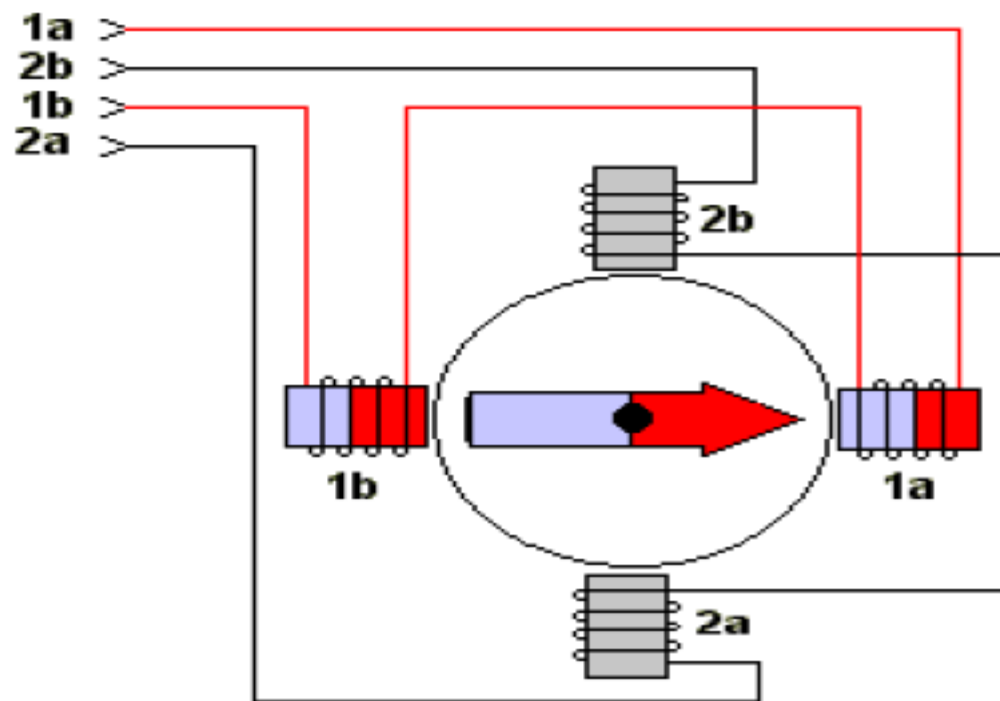
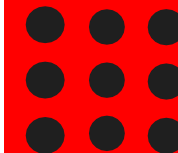

Conceptual Model of Bipolar Stepper Motor



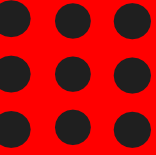

Full Stepping

- Energizing one coil at a time is known as running the motor in 'full steps'. In a 200 step motor, this means the resolution of the motor is 200 positions for a single revolution; 200 separate rotational positions that can be achieved. **Half Stepping**
- There is a trick you can do to double the resolution of the motor; instead of just energizing one coil at a time in order, you can create positions *inbetween* by energizing the next coil in the sequence, before de-energizing the current coil. This also makes for smoother motion at slower speeds.
- Stepper motors can be controlled with bipolar techniques, to strengthen the motor's ability to turn, and to lock. Rather than energizing single coils, one is energized with a positive voltage, while the opposite coil is given a negative voltage. Running a motor using bipolar techniques does NOT affect the resolution of the motor, only power and maximum running speed.
- Here's an animated diagram showing a bi-polar half-step sequencing technique. Note that there are 8 half steps to this sequence. The rotor shaft is in the center, and is a fixed magnet. The four coils around it are energized in the order shown to achieve shaft rotation



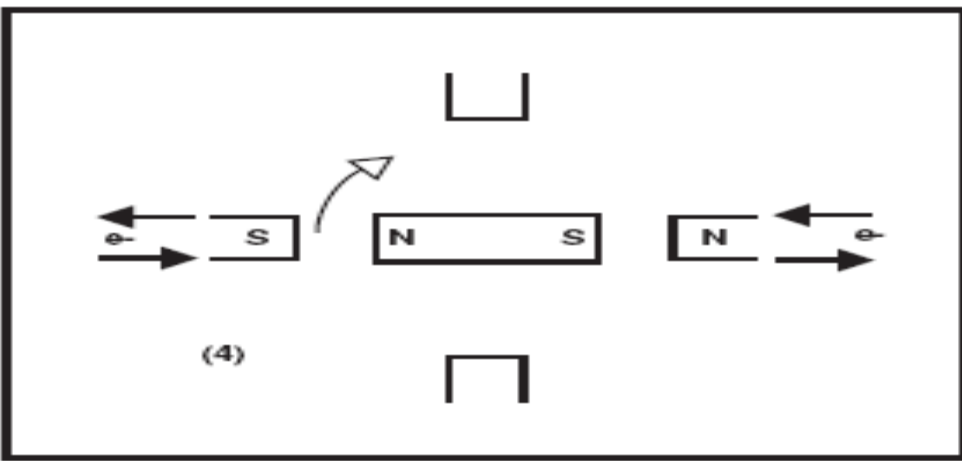
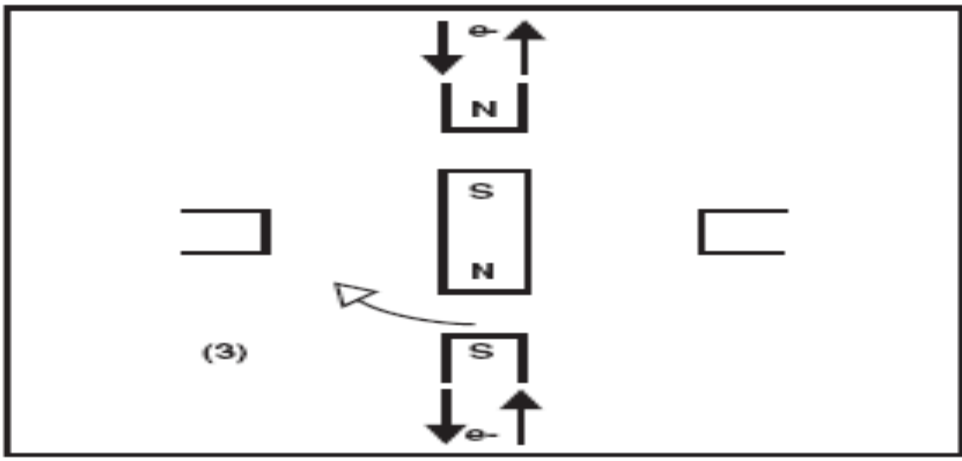
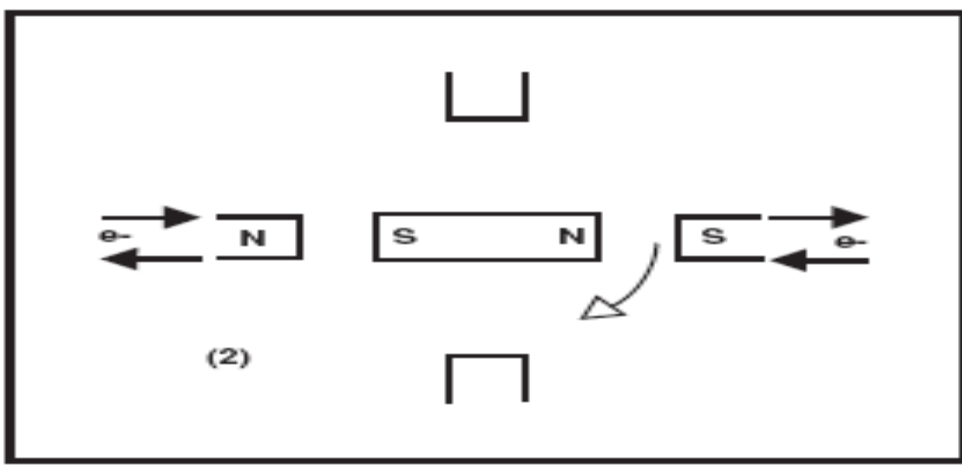
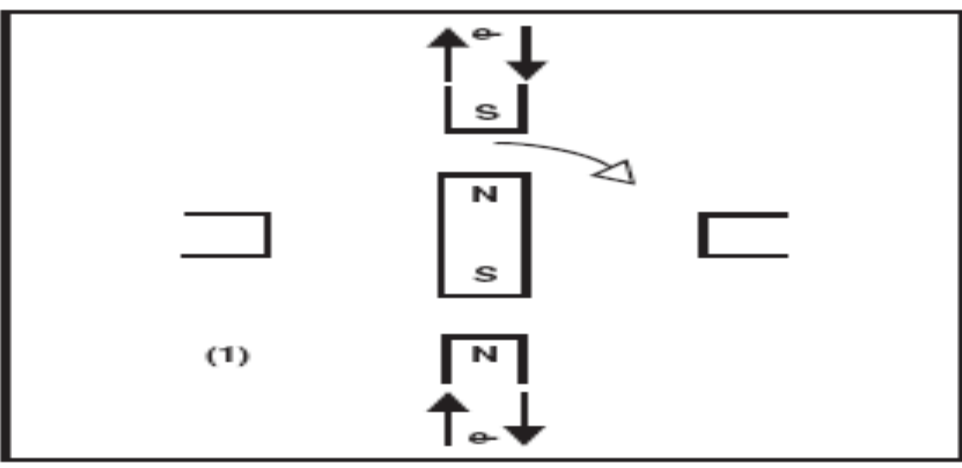

	PHASE			
	A	B	\bar{A}	\bar{B}
1	1	0	0	0
2	0	1	0	0
3	0	0	1	0
4	0	0	0	1

One-Phase On, Full Step
Figure 5a.

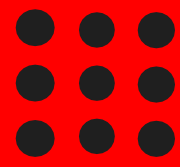

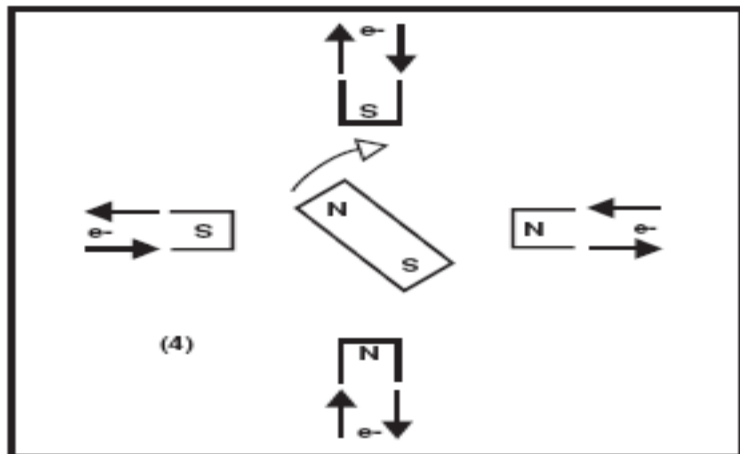
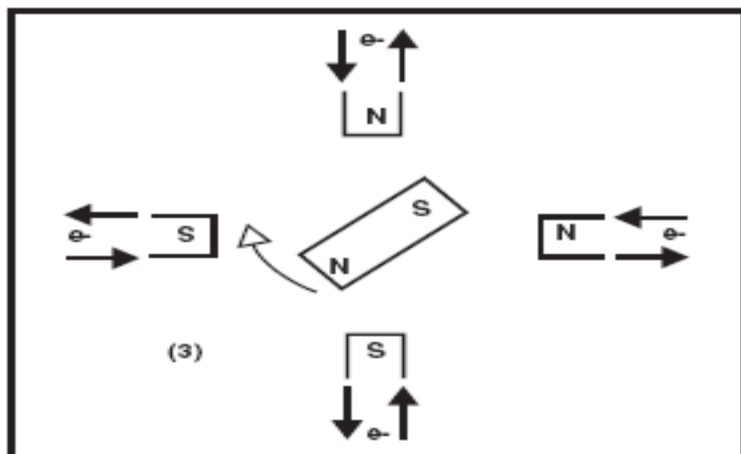
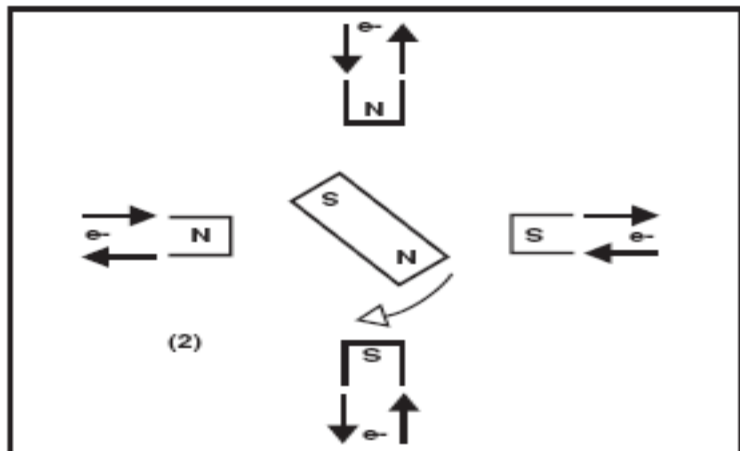
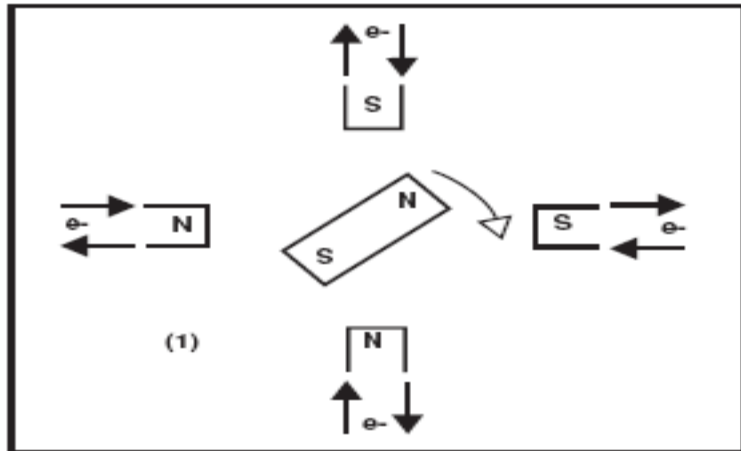

Two-Phase On, Full Step

Figure 5b. STEPPER MOTORS/19EC309- EM&PS/MANIV/EEE/SNSCE

	PHASE			
	A	B	\bar{A}	\bar{B}
1	1	1	0	0
2	0	1	1	0
3	0	0	1	1
4	1	0	0	1

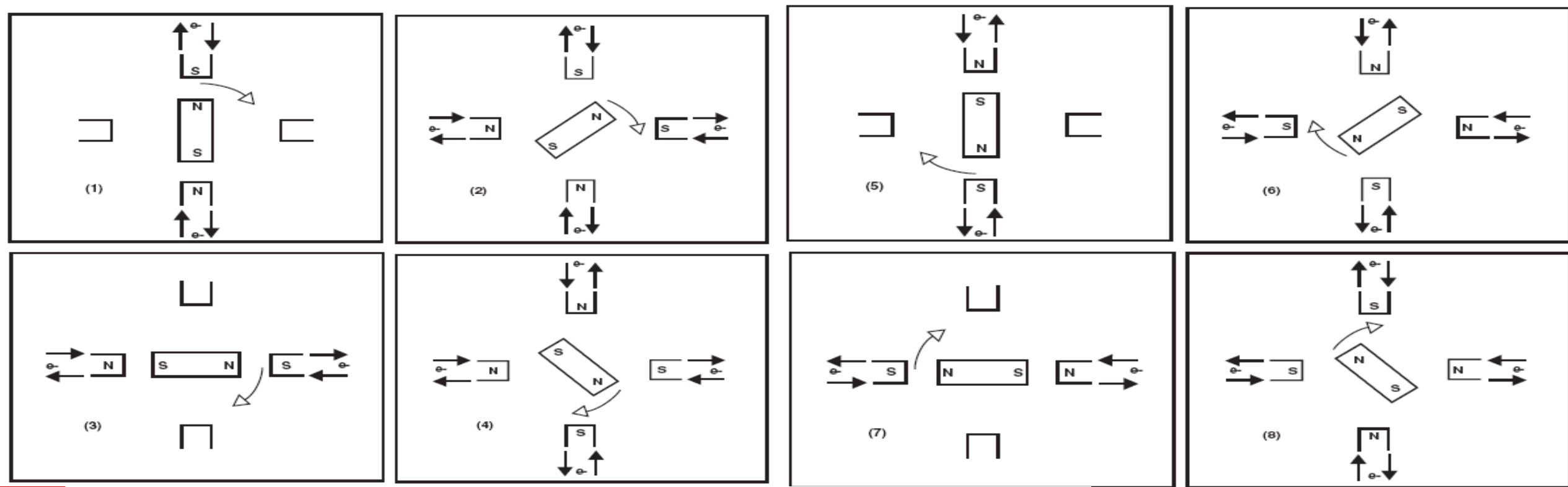

Half Step
Figure 6.

	PHASE			
	A	B	\bar{A}	\bar{B}
1	1	0	0	0
2	1	1	0	0
3	0	1	0	0
4	0	1	1	0
5	0	0	1	0
6	0	0	1	1
7	0	0	0	1
8	1	0	0	1





Stepping Sequence

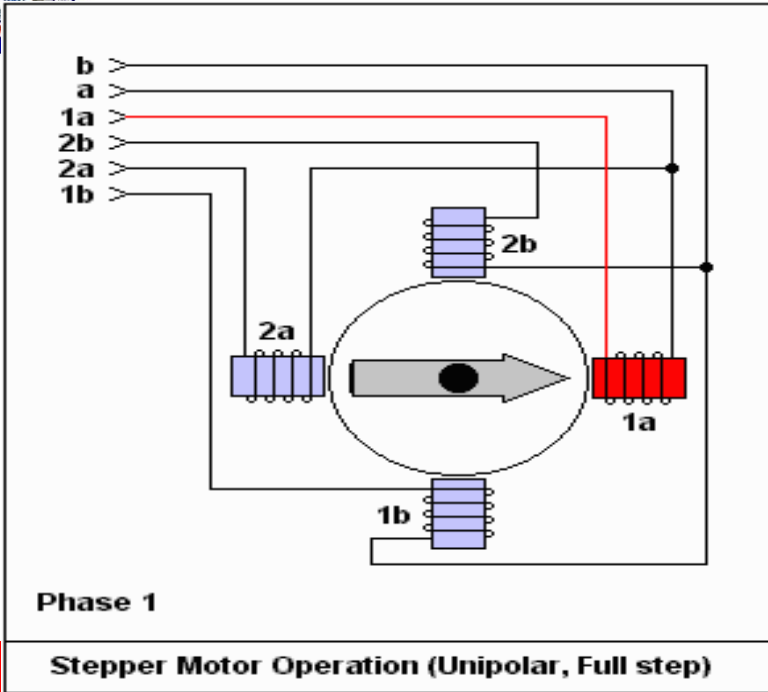

Clockwise Rotation →

Index	1a	1b	2a	2b
1	1	0	0	0
2	0	1	0	0
3	0	0	1	0
4	0	0	0	1
5	1	0	0	0
6	0	1	0	0
7	0	0	1	0
8	0	0	0	1

Clockwise Rotation →

Index	1a	1b	2a	2b
1	1	0	0	0
2	1	1	0	0
3	0	1	0	0
4	0	1	1	0
5	0	0	1	0
6	0	0	1	1
7	0	0	0	1
8	1	0	0	1
9	1	0	0	0
10	1	1	0	0
11	0	1	0	0
12	0	1	1	0
13	0	0	1	0
14	0	0	1	1
15	0	0	0	1
16	1	0	0	1

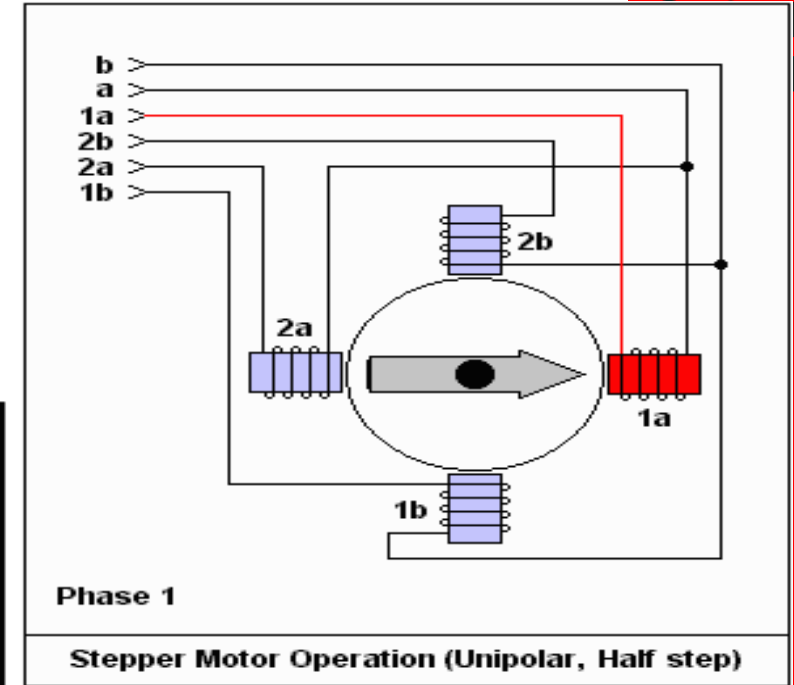

- Full step sequence showing how binary numbers can control the motor

- Half step sequence of binary control numbers



Full Stepping

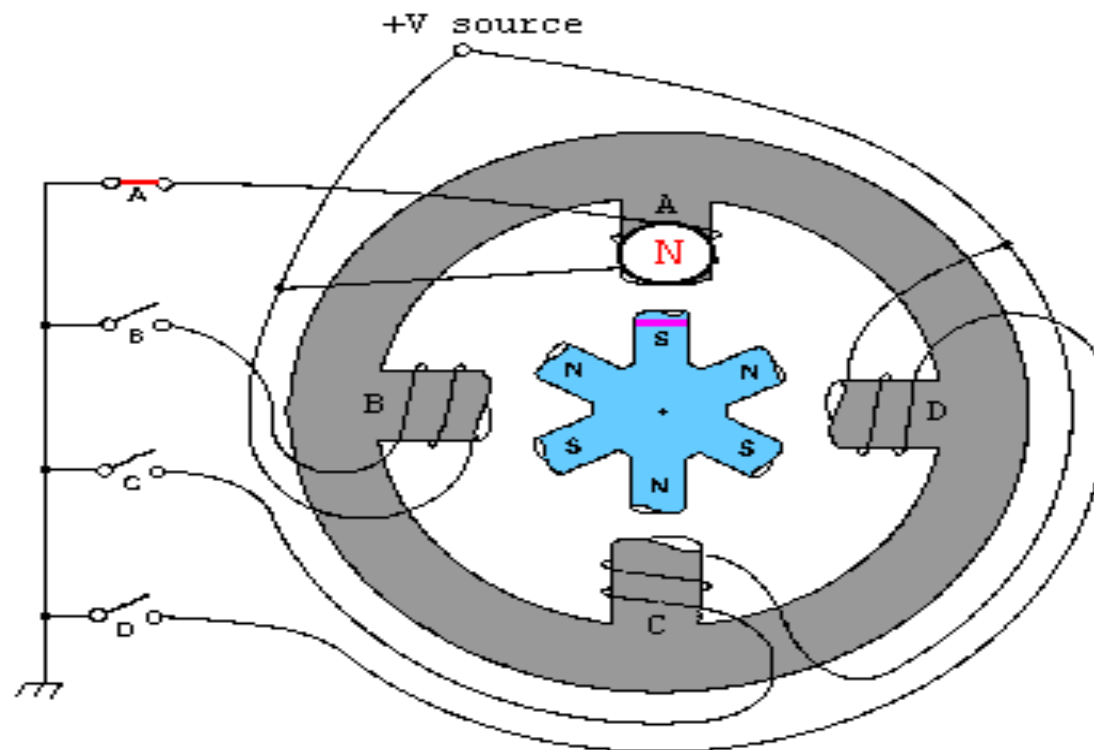

- Animation shows how coils are energized for full steps



**Half Step Clockwise
Stepper Motor Rotation
Position 1 of 8**

off

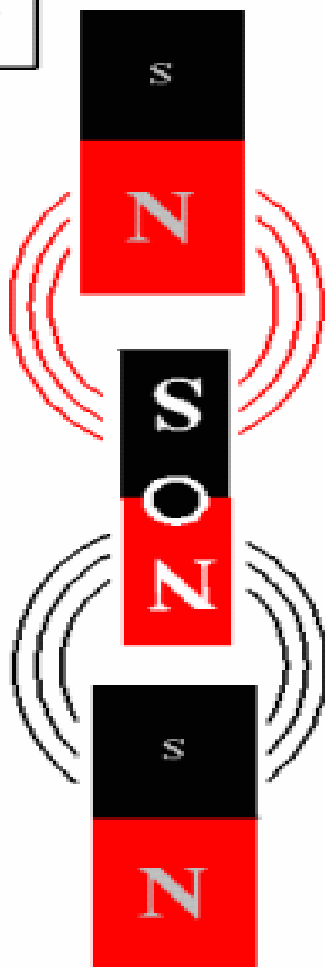

off

(c) 1998 Copyright Greg Ercolano

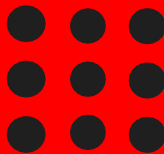



Single

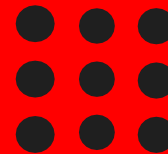
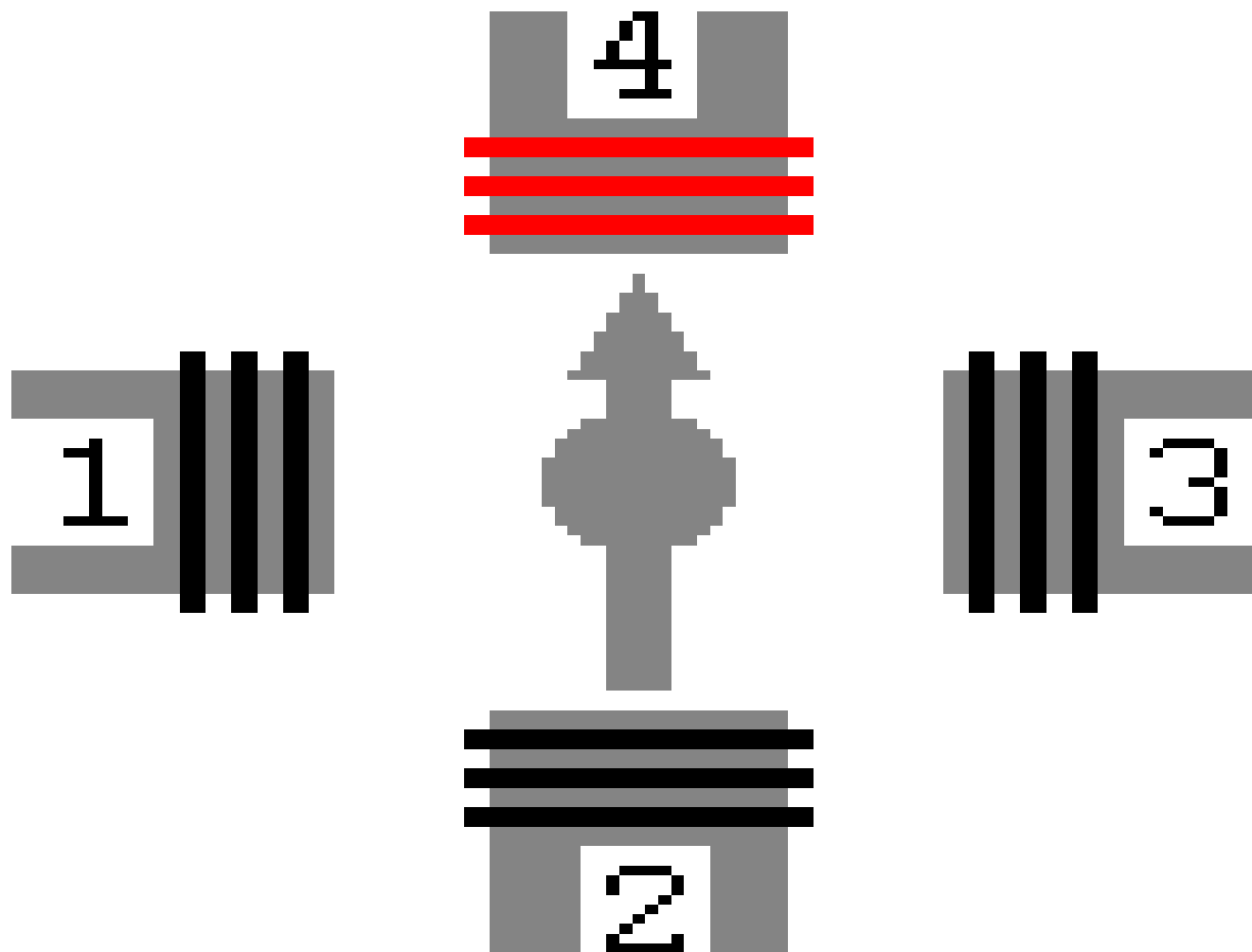



Dual

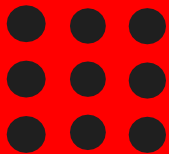
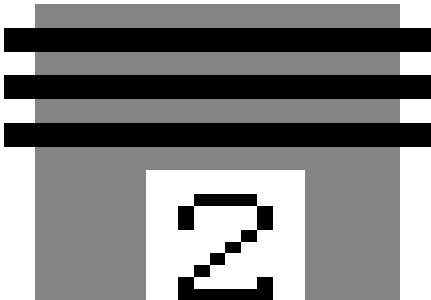
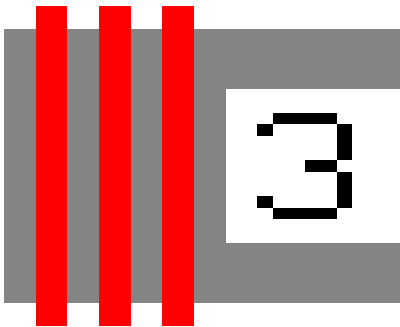
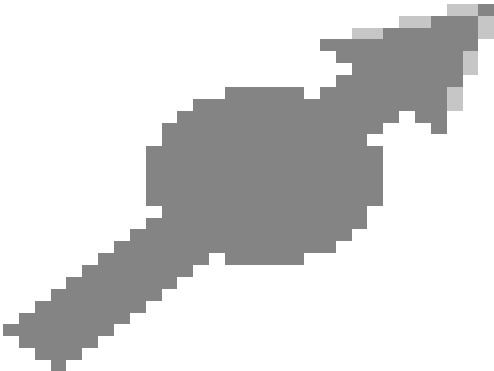
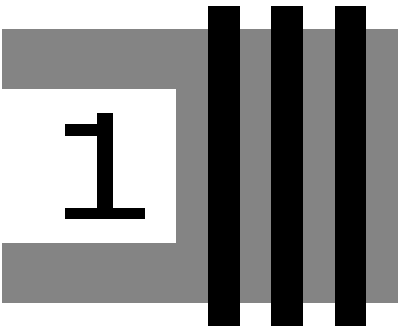
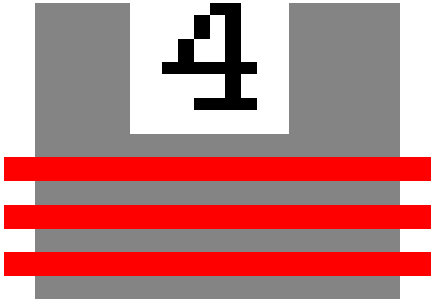



Both

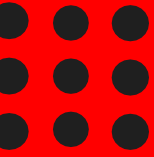
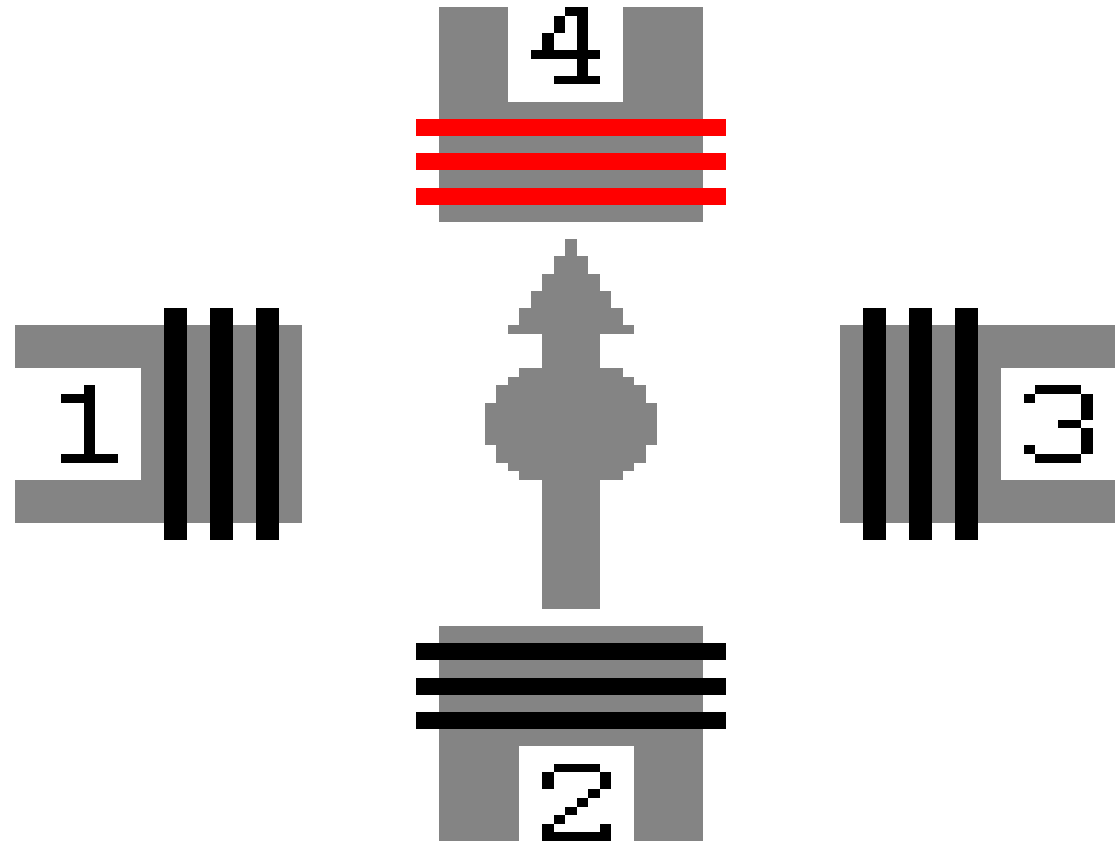

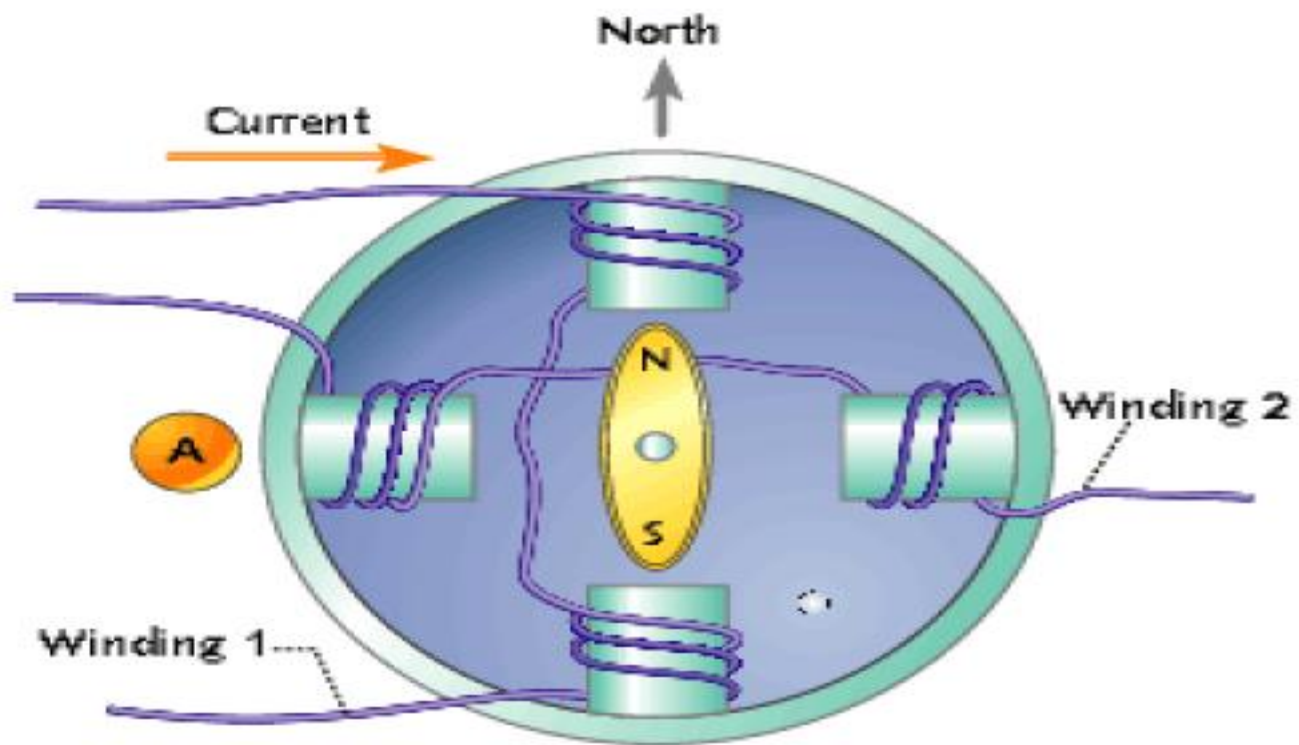
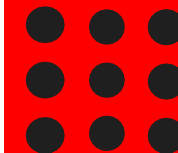

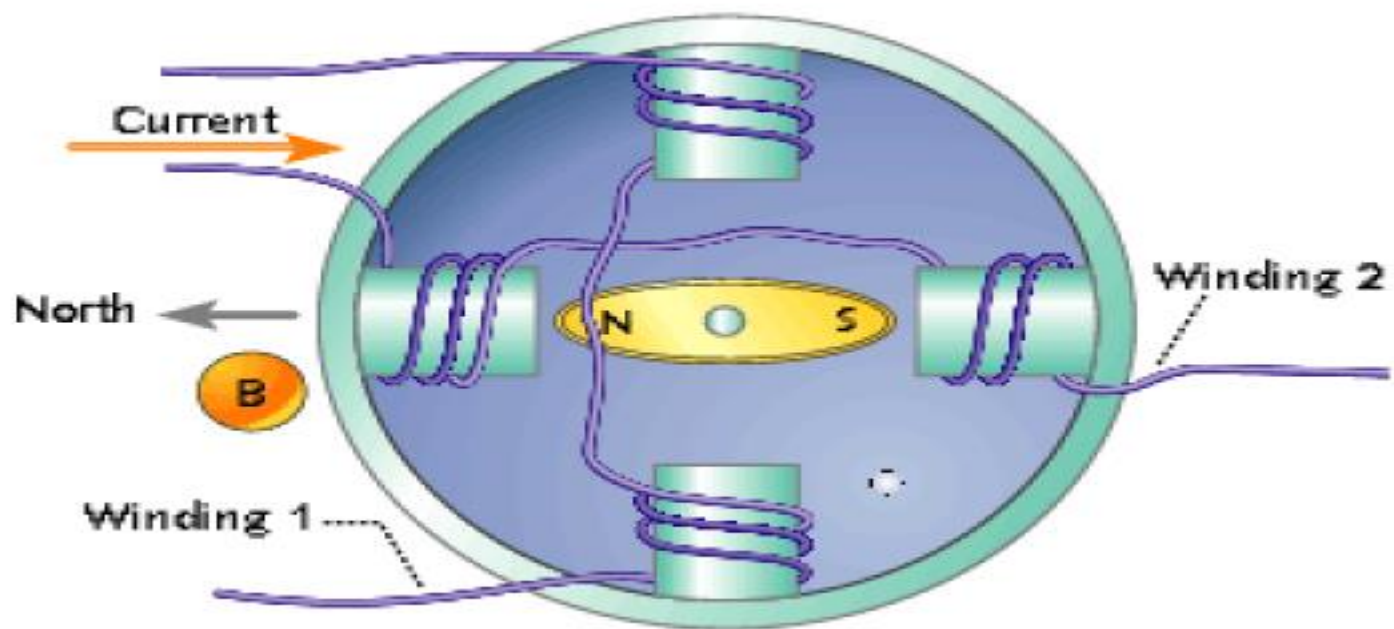
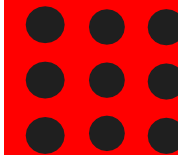

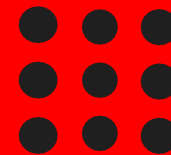
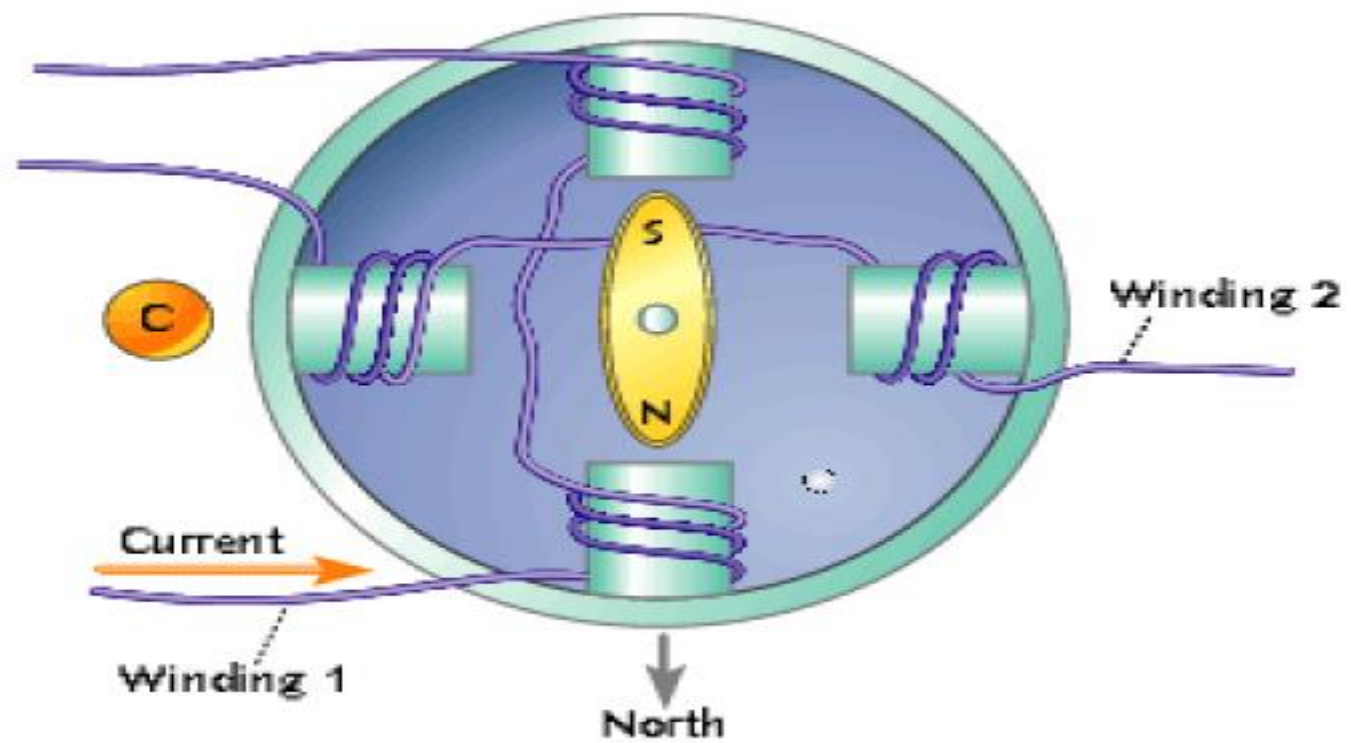

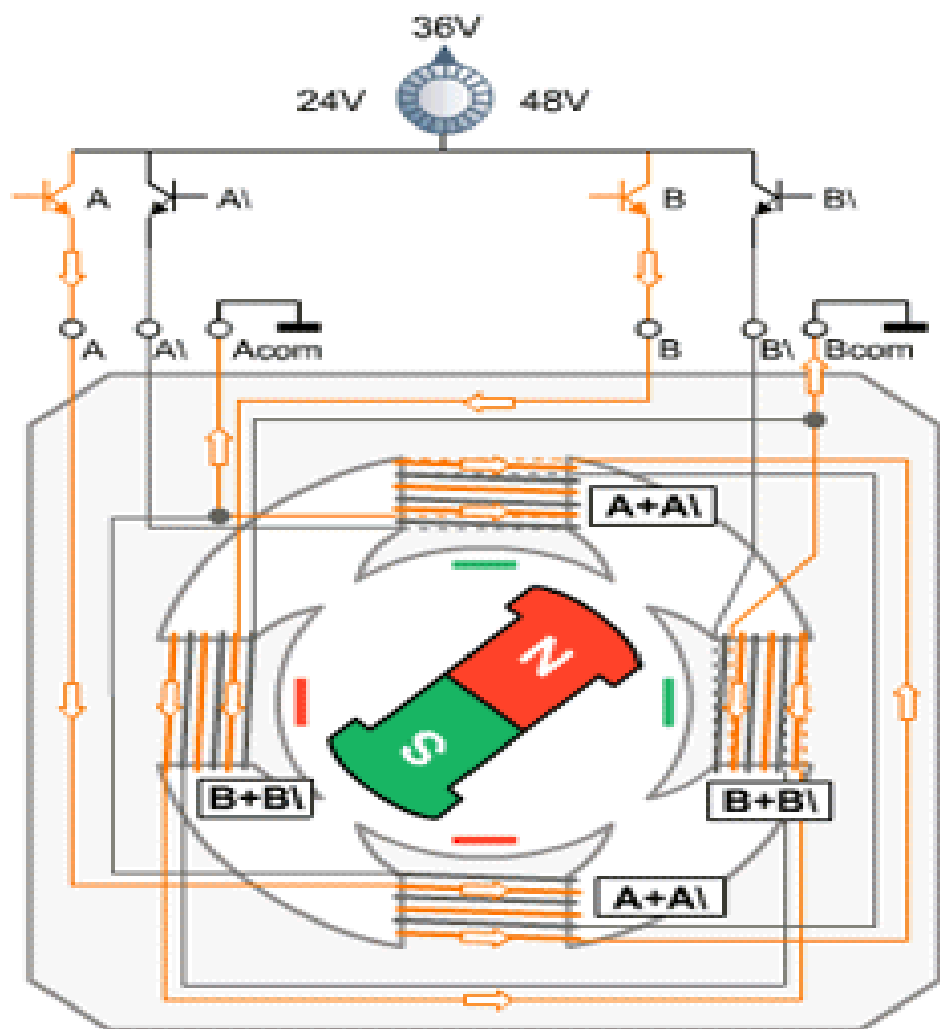
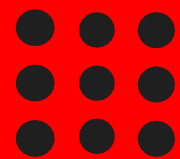

6 Lead Unipolar Driver

Unipolar control is the most simple and cost-effective way to drive a stepper motor, but results in approximately 30% less torque in comparison to the nowadays widely used bipolar drivers. Since the cost advantage is very small today due to cheap integrated circuits, bipolar drivers are now used in most new applications.

Stepmode								
F	0	1	2	3				
H	0	1	2	3	4	5	6	7
A	1	0	0	0	0	0	1	1
B	1	1	1	0	0	0	0	0
A'	0	0	1	1	1	0	0	0
B'	0	0	0	0	1	1	1	0
dez	12	4	6	2	3	1	9	8





Full Stepper Motor

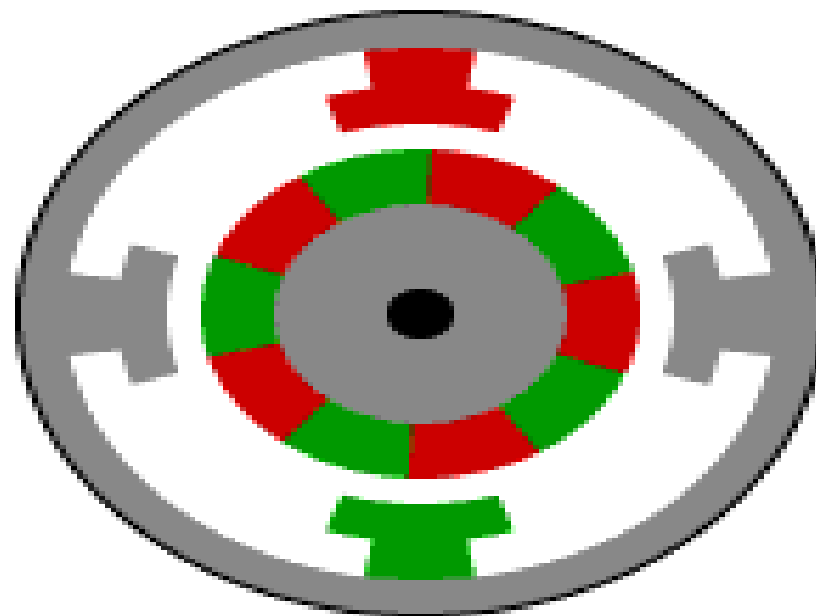

- This animation demonstrates the principle for a stepper motor using full step commutation. The rotor of a permanent magnet stepper motor consists of permanent magnets and the stator has two pairs of windings. Just as the rotor aligns with one of the stator poles, the second phase is energized. The two phases alternate on and off and also reverse polarity. There are four steps. One phase lags the other phase by one step. This is equivalent to one fourth of an electrical cycle or 90° .



Half Stepper Motor

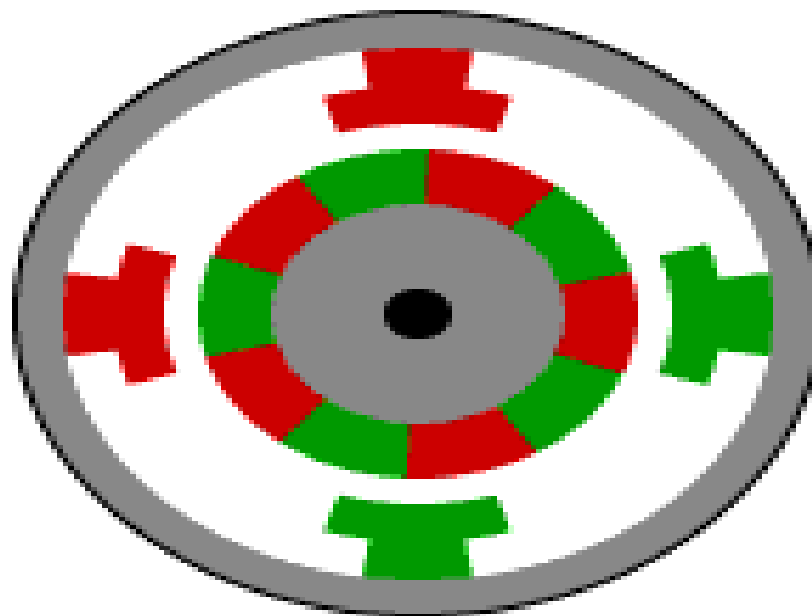

- This animation shows the stepping pattern for a half-step stepper motor. The commutation sequence for a half-step stepper motor has eight steps instead of four. The main difference is that the second phase is turned on before the first phase is turned off. Thus, sometimes both phases are energized at the same time. During the half-steps the rotor is held in between the two full-step positions. A half-step motor has twice the resolution of a full step motor. It is very popular for this reason.



Stepper Motors

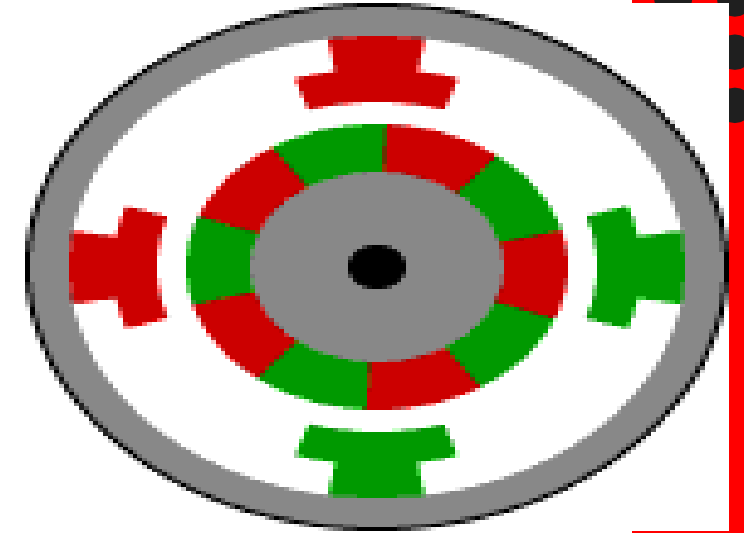
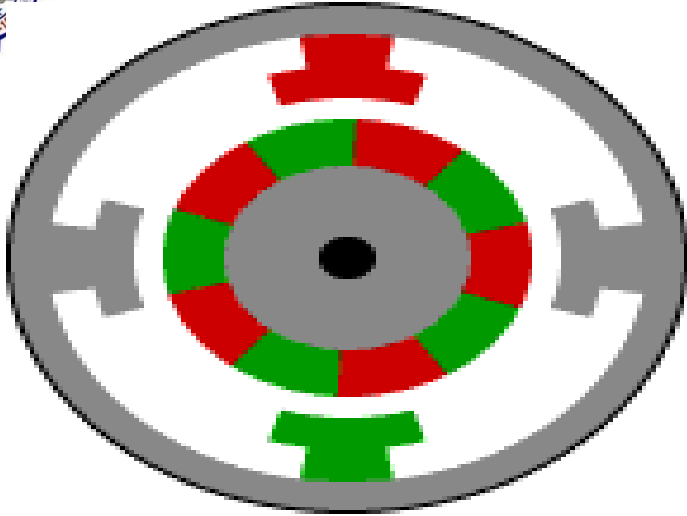

- Some stepper motor uses permanent magnets. Some stepper motors do not have magnets and instead use the basic principles of a switched reluctance motor. The stator is similar but the rotor is composed of a iron laminates.





Film Advance

Application Examples

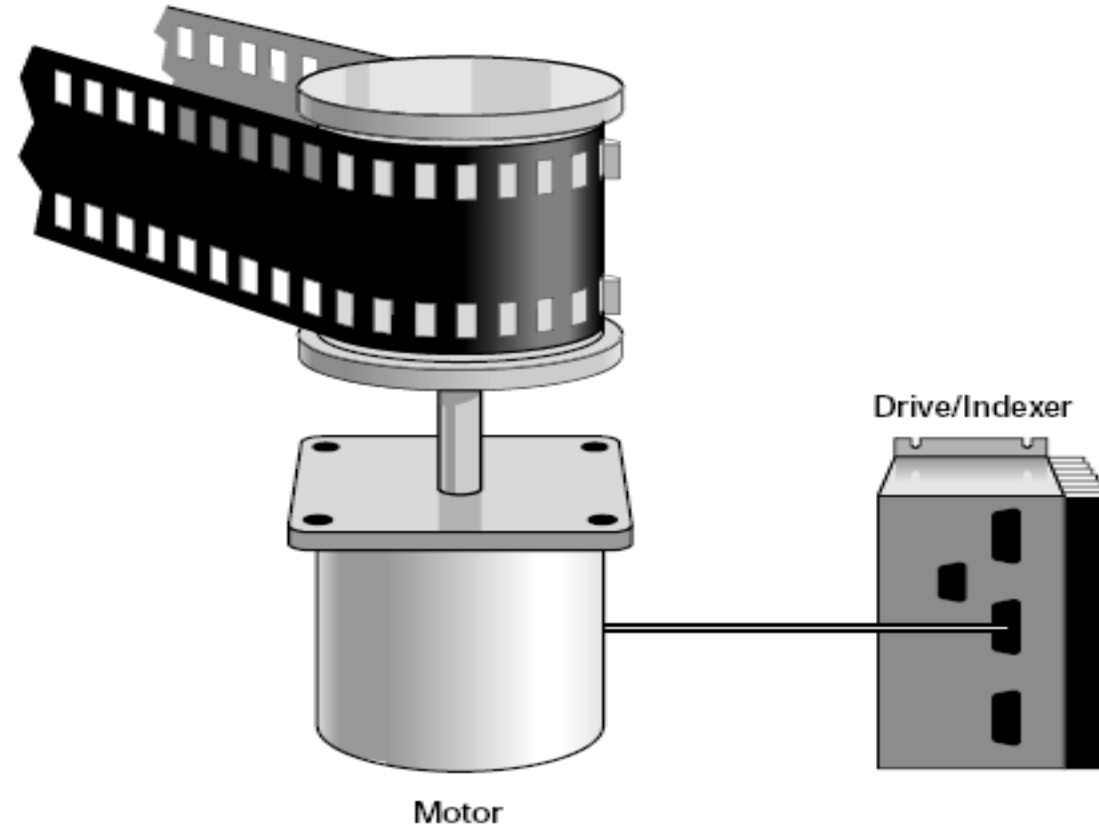



Telescope Drive

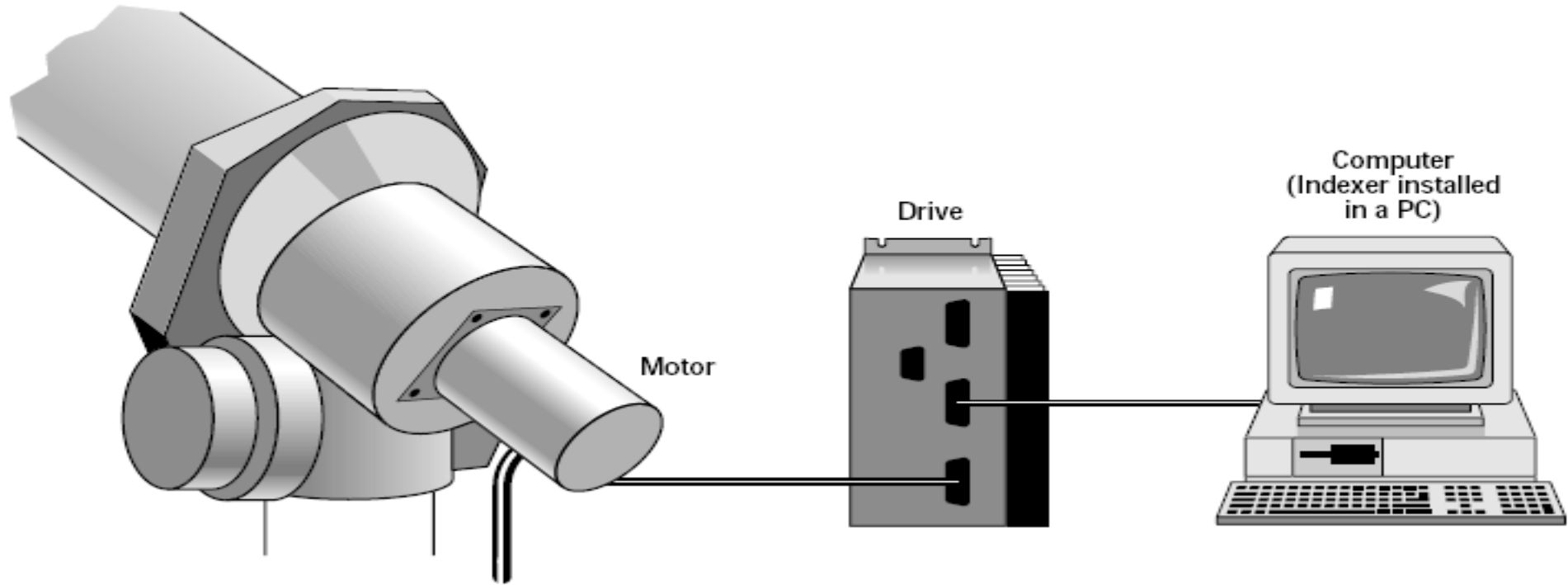



Labeling Machine

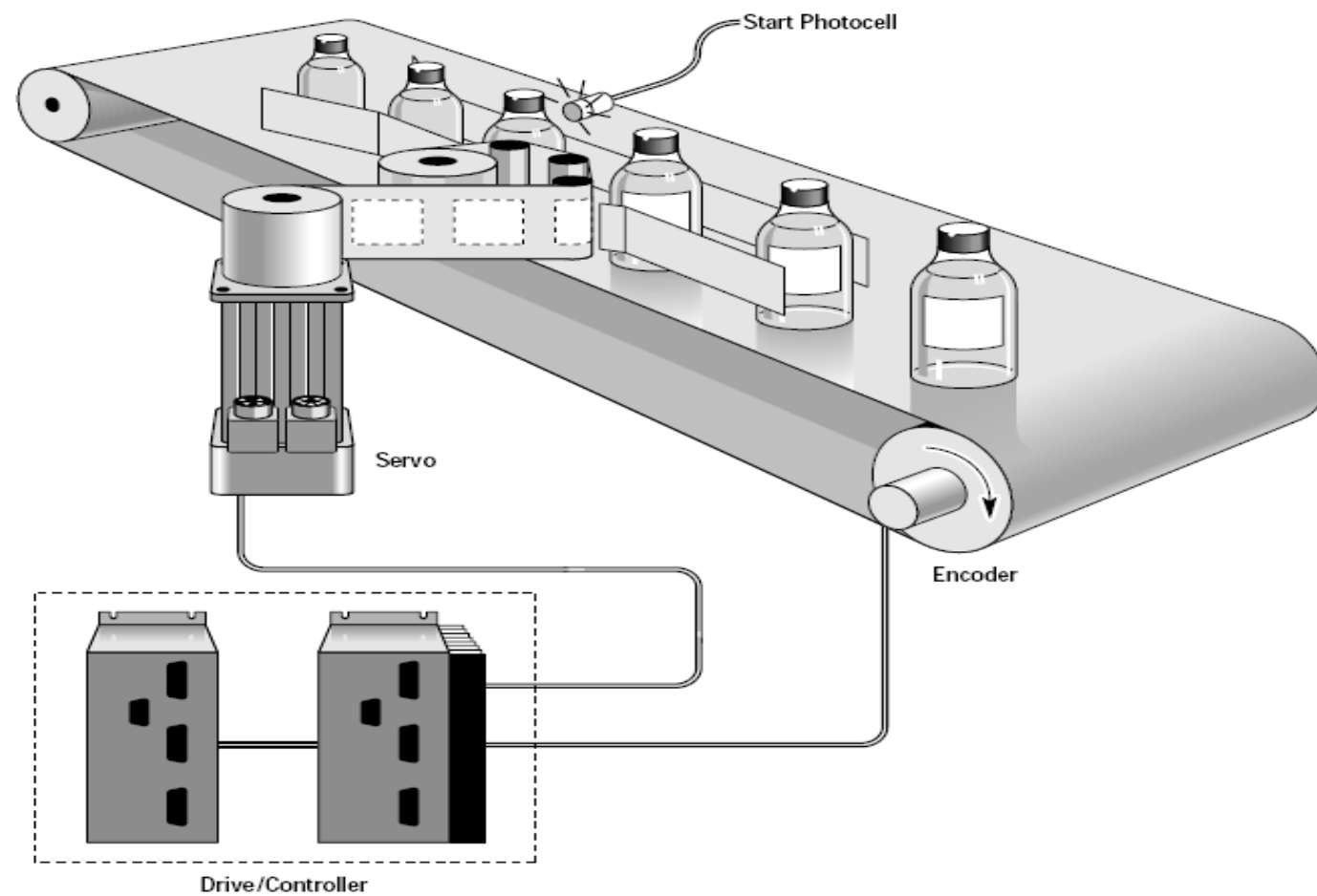

Drive/Controller
STEPPER MOTORS/19EC309- EM&PS/MANI V/EEE/SNSCE



Moving Positioning System

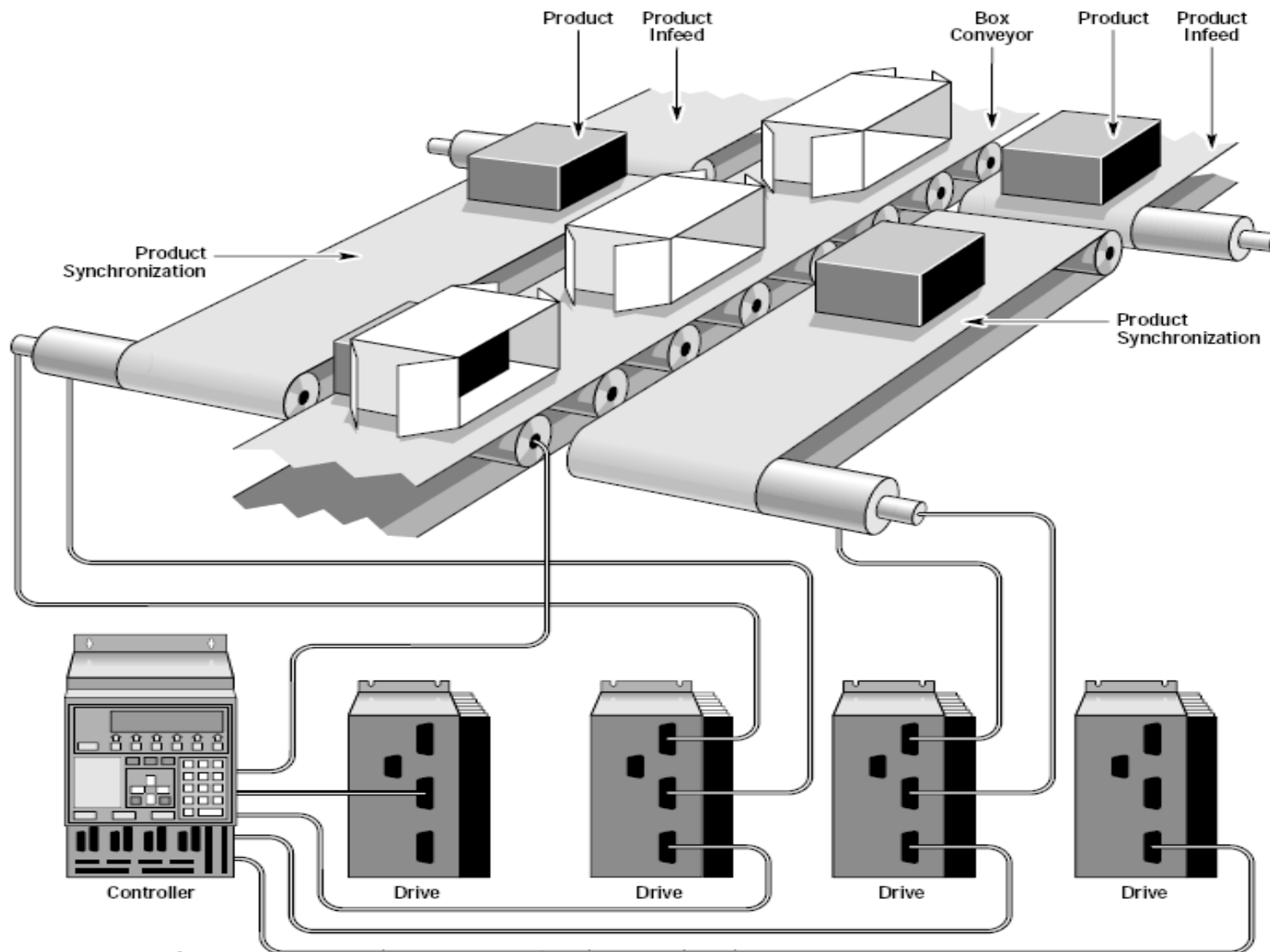



Rotating Tube Cutter

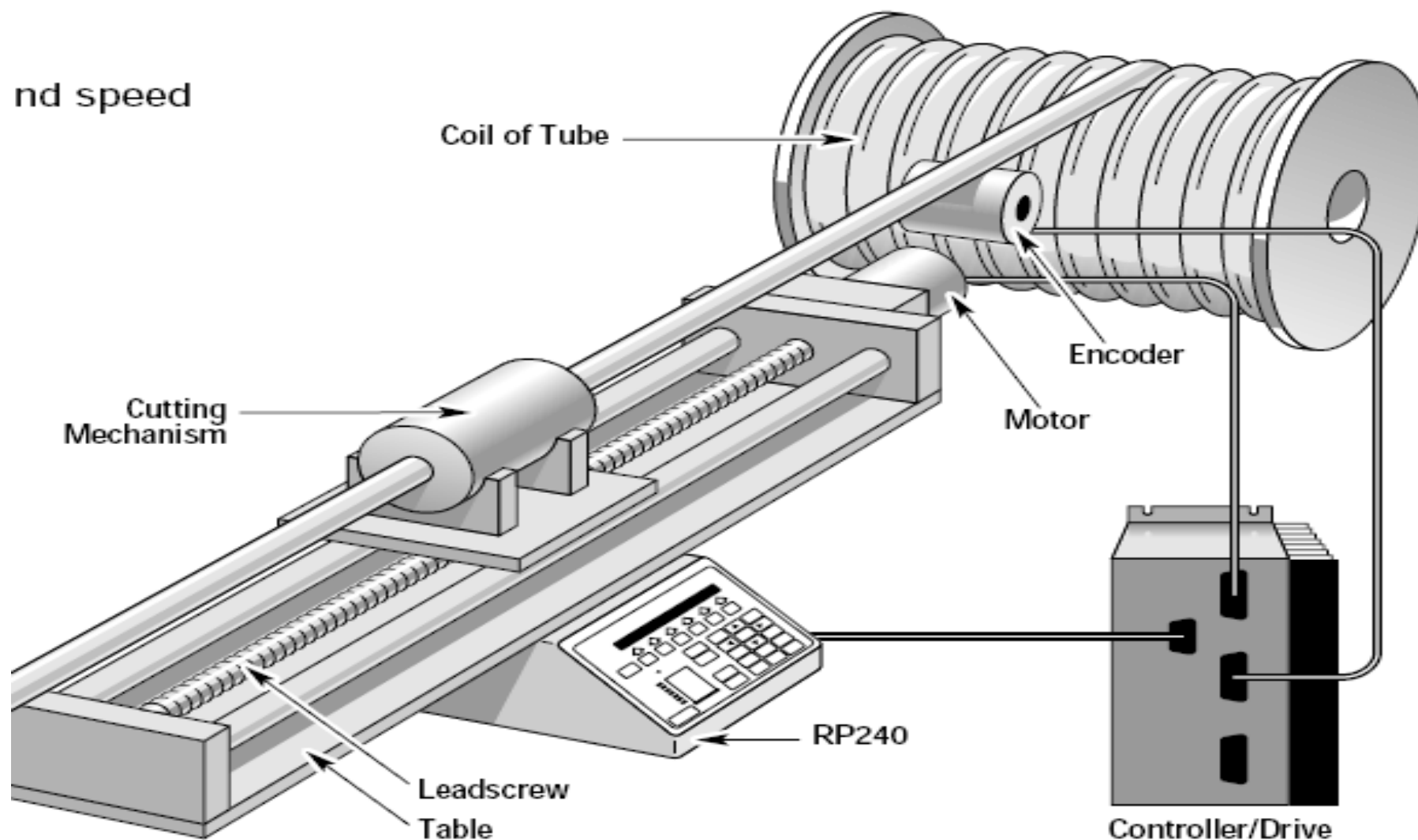

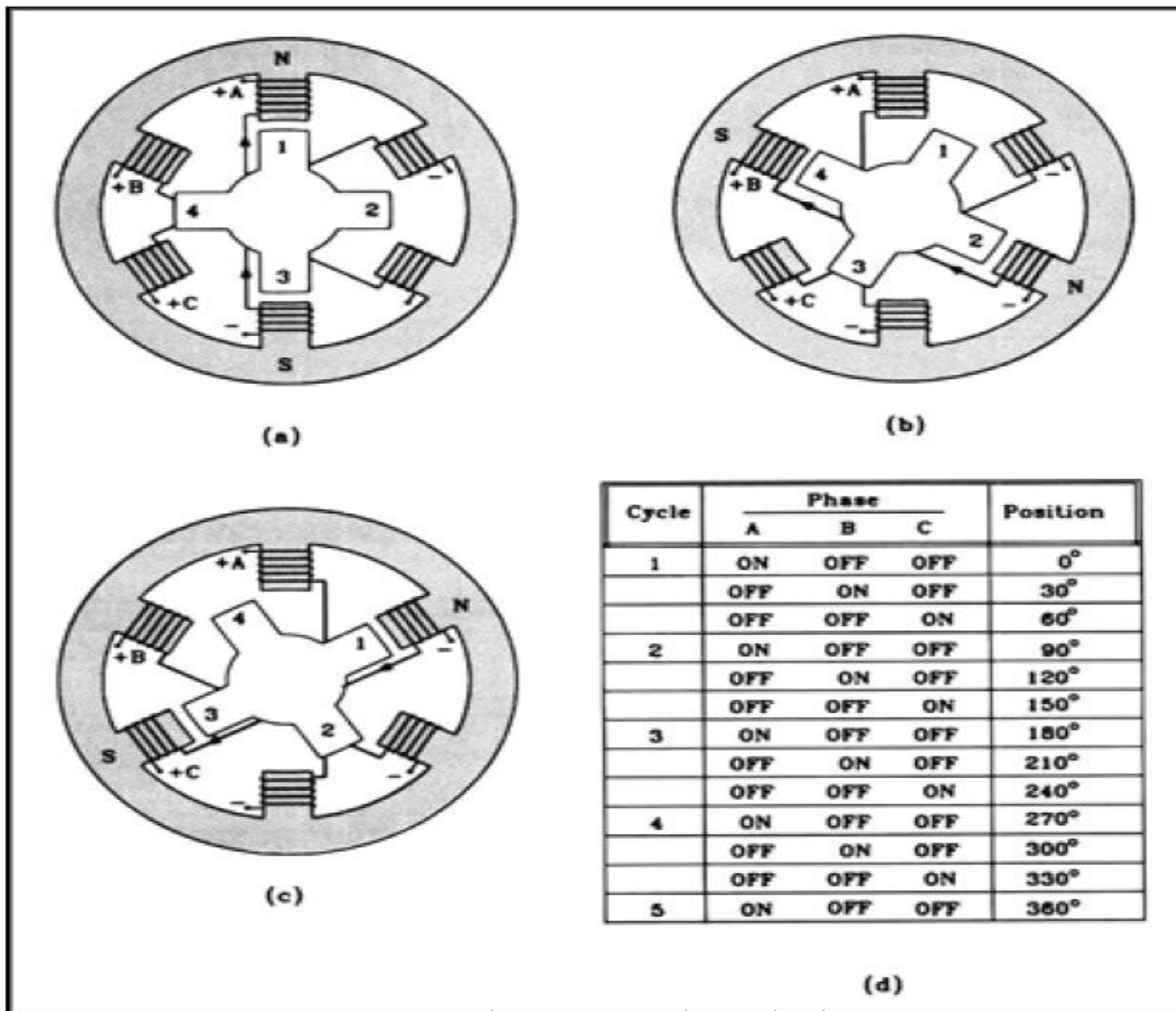

Figure 6-21 Variable-reluctance stepper motor and switching sequence.



$$N = \frac{\Psi(s/s)}{6}$$

where N = motor speed, in RPM

Ψ = step angle, in mechanical degrees

s/s = number of steps per second

A stepper motor with a step angle of 15° has a maximum rating of 300 s/s. What is the motor speed?

$$\begin{aligned} N &= \frac{\Psi(s/s)}{6} \\ &= \frac{(15^\circ)(300)}{6} \\ &= 750 \text{ RPM} \end{aligned}$$

$$\text{Step Angle } (\Theta_s) = \frac{360^\circ}{S}$$

$$S = mN_r$$

m = number of phases

N_r = number of rotor teeth

For this motor:

$$m = 3$$

$$N_r = 4$$

$$S = mN_r = 3 \cdot 4 = 12$$

$$\Theta_s = \frac{360^\circ}{12} = 30^\circ \text{ per step}$$

