

Co ordinate Measuring Machine(CMM)

ME0403- Metrology and Quality  
Control

# Complex Jobs to be measured



# Complex Jobs to be measured

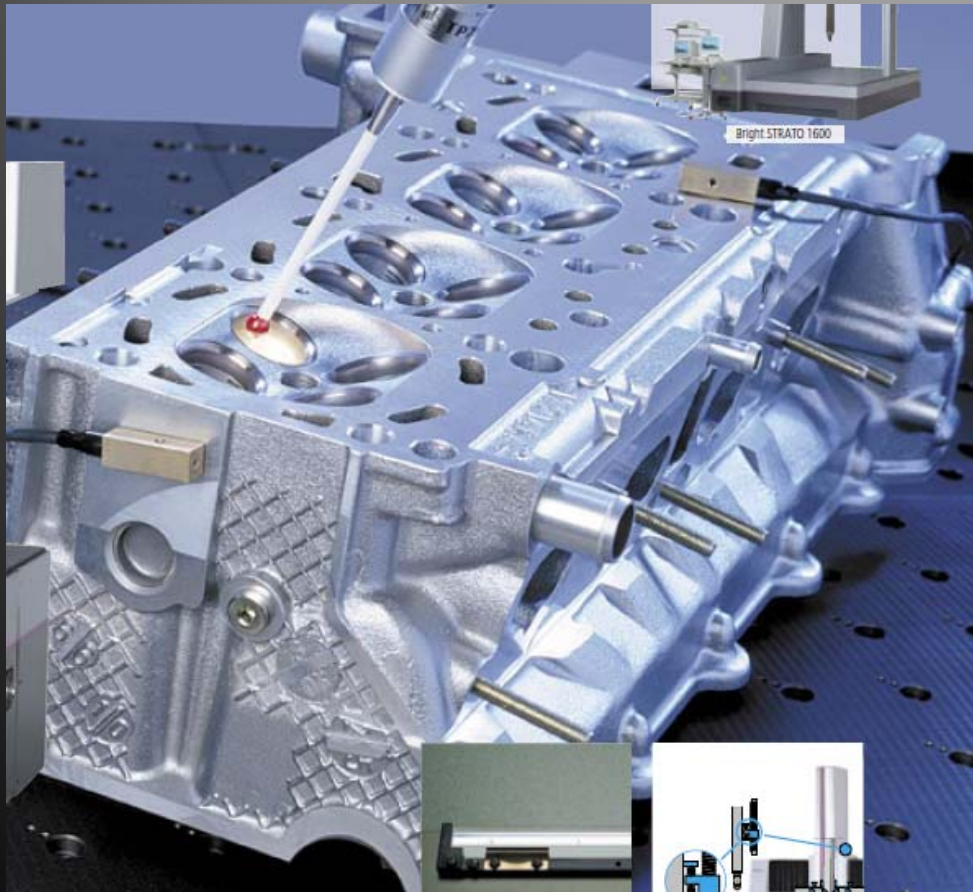

# Complex Jobs to be measured

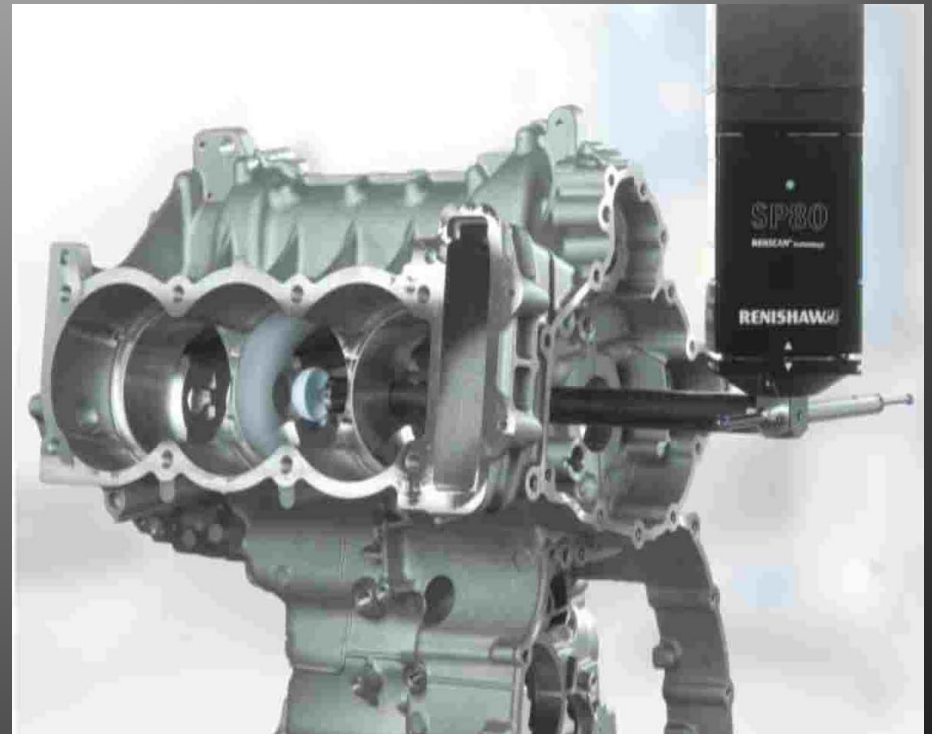

## Functions of CMM

- To measure the actual size of w/p comparison with desired shape and evaluation of metrological information such as
  - Size
  - Form
  - Location
  - Position
- Actual size is obtained by probing the surface at discrete measuring points. Every pt is expressed in terms of its x,y,z coordinates

## CMM system components

- Mechanical Setup with 3 axes movement & the displacement transducer
- Probe head to probe the work piece in a spatial direction
- Control Unit
- Computer with software to calculate & represent the results

# Mechanical Set up

## Air bearings on all axes

Self-adjusting air bearings on all axes enable outstanding smoothness, speed and precision in movement. They form the basis for absolute measuring accuracy.

## Thermally stable glass scales with "zero" thermal expansion

All versions in the LEGEX series are equipped with the new optoelectronic length measuring system with a resolution of  $0.01\mu\text{m}$  and glass scales with a thermal expansion coefficient of  $0.01 \times 10^{-6}/^{\circ}\text{C}$ .

## Low-vibration system provides reassuring reliability

Self-levelling high-performance shock absorbers make LEGEX machines reassuringly reliable, even when the floor itself shakes and vibrates.



## Outstanding accuracy based on new design principles

The measuring table moves in the Y axis in the base using the "moving table" principle, completely independently from the portal. Outstanding geometrical accuracy ensures that deformation of the base due to load movements is eliminated.

## Exceptional geometrical and kinematic accuracy

The excellent geometrical and kinematic accuracy of LEGEX machines is due to the fixed-portal principle.

## Faster and more accurate with ceramic-coated guides

The LEGEX versions of the 500 series and upwards come standard with ceramic coating of the Y and X guides as well as the sleeve.

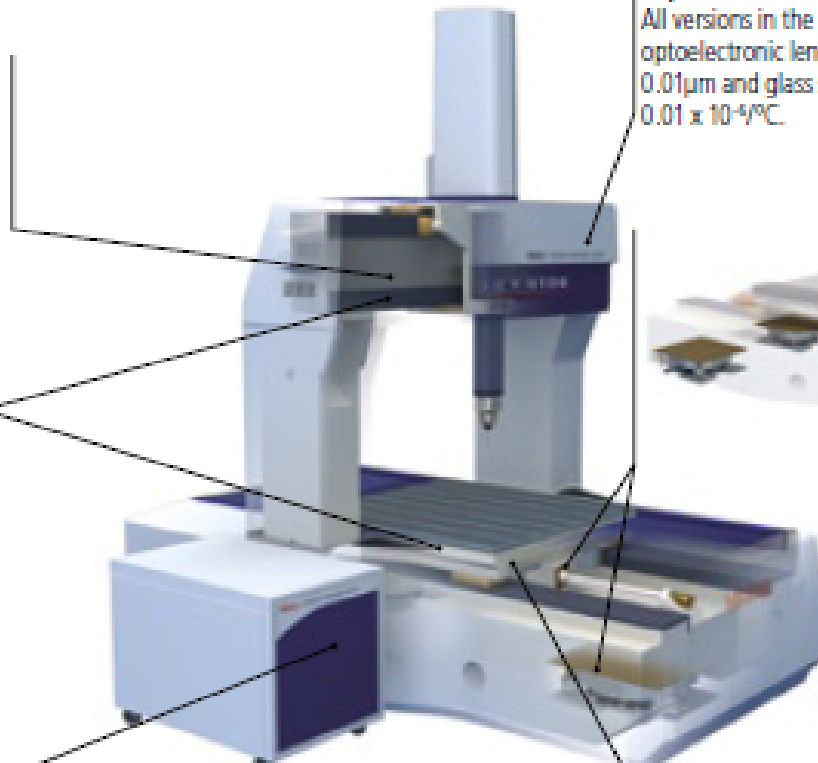

## Highly dynamic, flexible digitized drive

The drive control for the LEGEX operates using an extremely powerful 32-bit digital signal processor (DSP). It perfectly controls the digital signals of all control circuits, travel movements, positions and speed for maximum measuring quality.

# Air Bearing

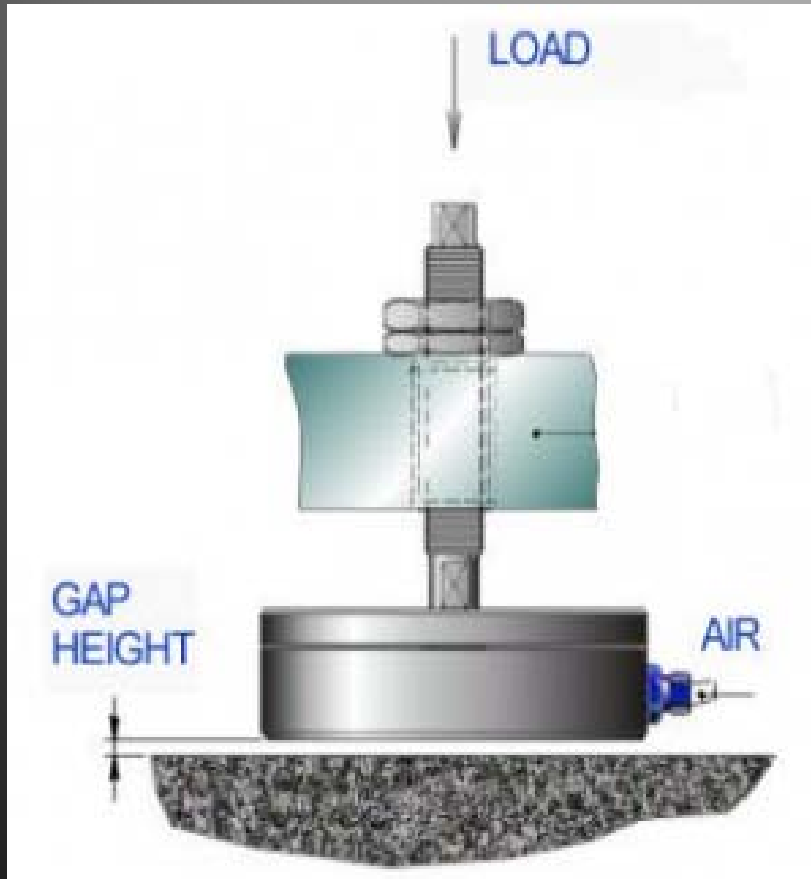

- Being non-contact, air bearings avoid the traditional bearing-related problems of friction, wear, and lubricant handling, and offer distinct advantages in precision positioning and high speed applications.



## Air Bearing

- The fluid film of the bearing is achieved by supplying a flow of air through the bearing itself to the bearing surface.
- Numerous bearing designs exist to ensure uniform pressure is distributed across the entire bearing area.
- The design of the air bearing is such that, although the air constantly dissipates from the bearing site, the continual flow of pressurized air through the bearing is sufficient to support the working loads.

# Probes and Probe Head

Touch-trigger probes

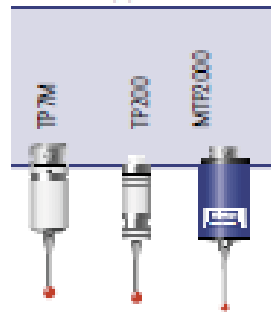

Dynamic measuring probes/measuring systems

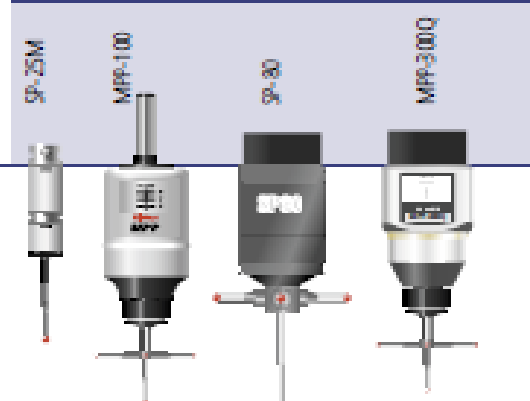

Optical measuring heads

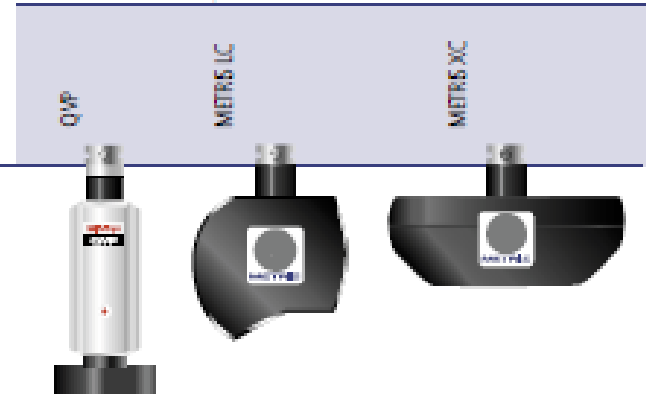

Special measuring probes  
for effective thread length  
measurement

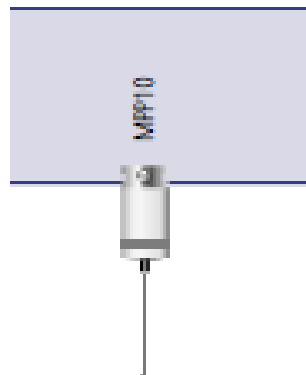

Measuring probe holder heads for manual  
coordinate measuring machines

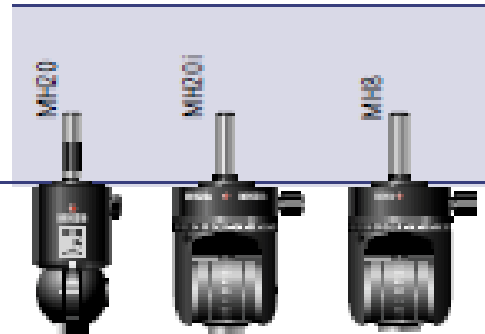

Measuring probe holder heads

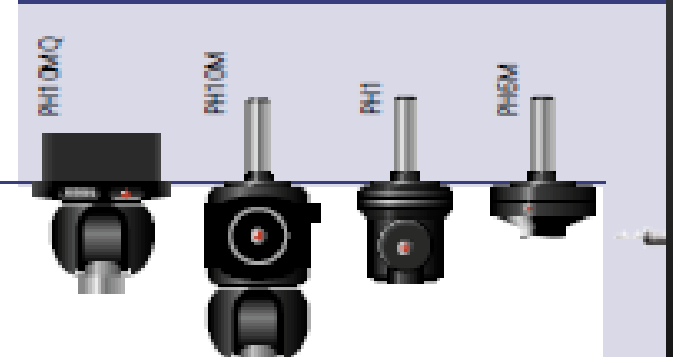

# Touch Trigger probe

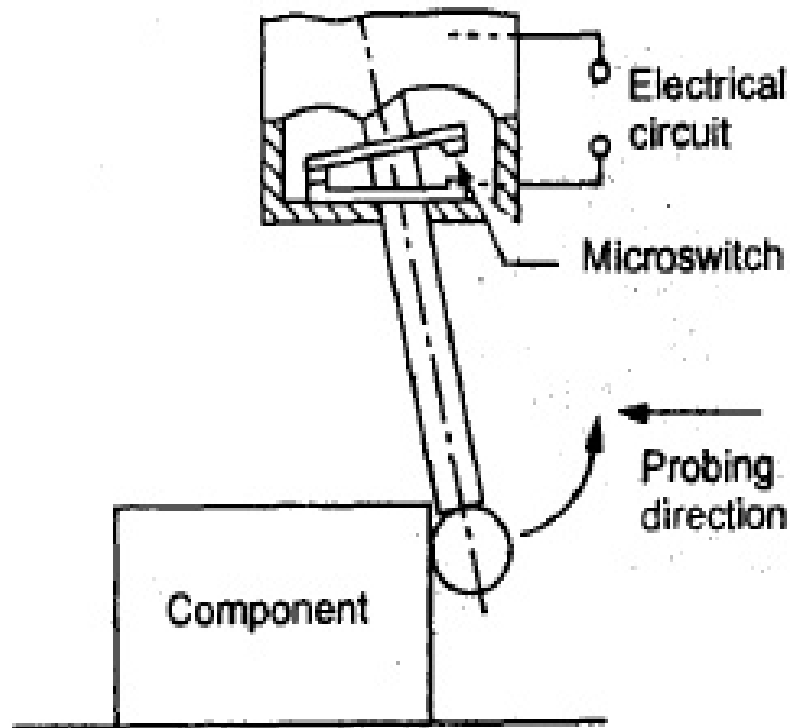

***(a) Part section of Probe head***

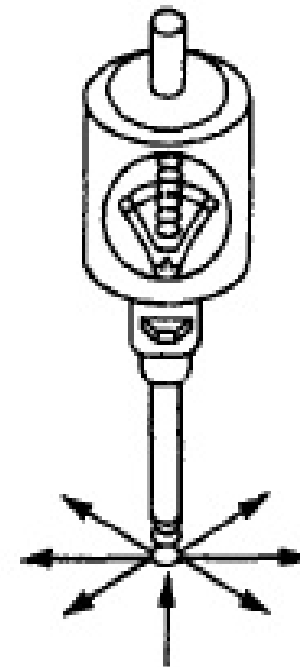

***(b) Outline of Probe head***

# Probe Changing System

ACR-1

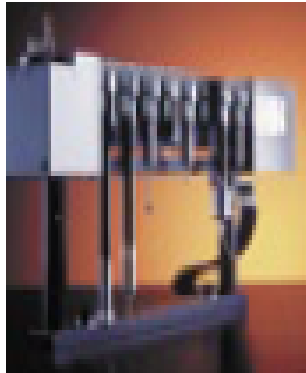

MRS-ACR3

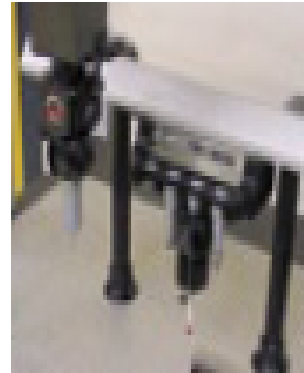

SCRMPF



SCR200

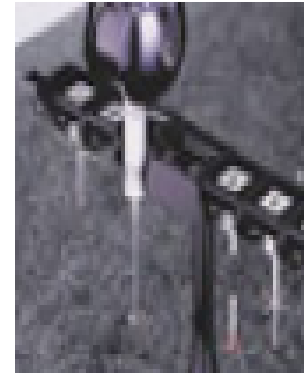

MRS-PCR25

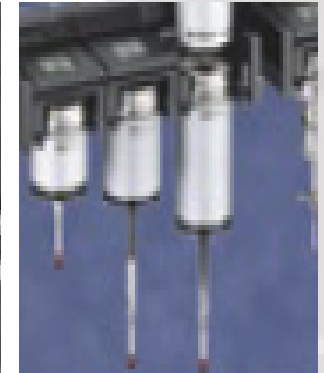

# Programming/Measurement with the CMM

- Step 1: Home the CMM
  - establishes global coordinate system(  $X_m, Y_m, Z_m$ )
- Step 2: Qualify the Tip( Calibration of probe tip with respect to probe head)
  - compensates for tip diameter
- Step 3: Align the Part
  - establishes a local coordinate system on the part( $X_w, Y_w, Z_w$ )
- Step 4: Measure the Part
- Step 5:Representation of measurement results after coordinate transformation into w/p related coordinates system

## Types of CMM

- Moving bridge
- Fixed bridge
- Cantilever
- Gantry

# Cantilever CMM( Manual)

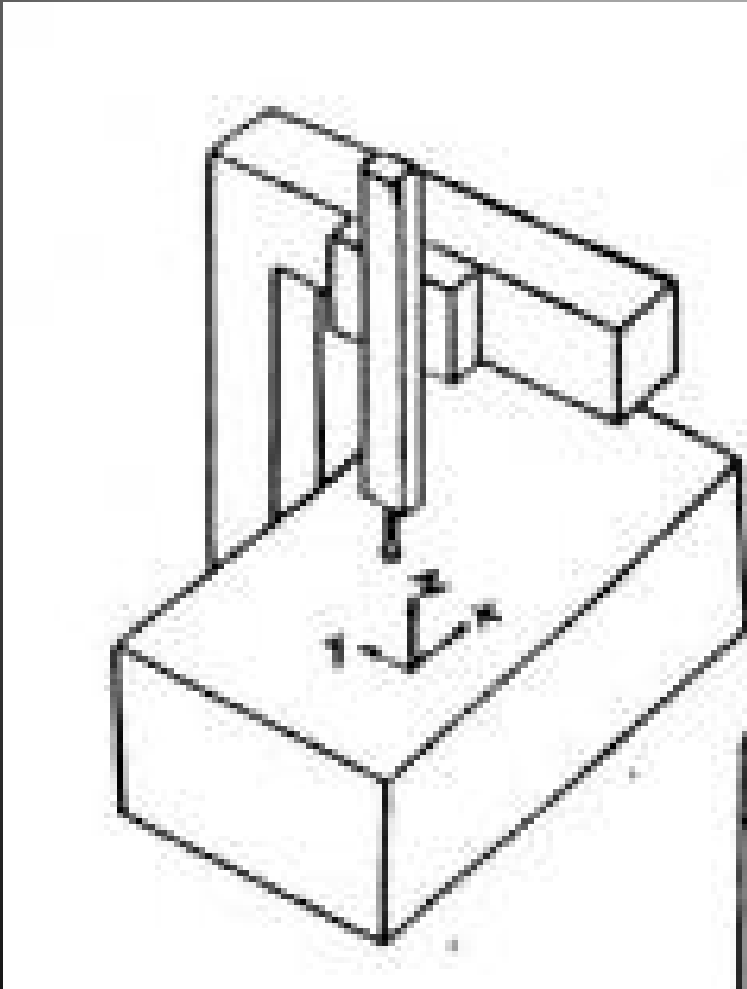

# Fixed Bridge CMM

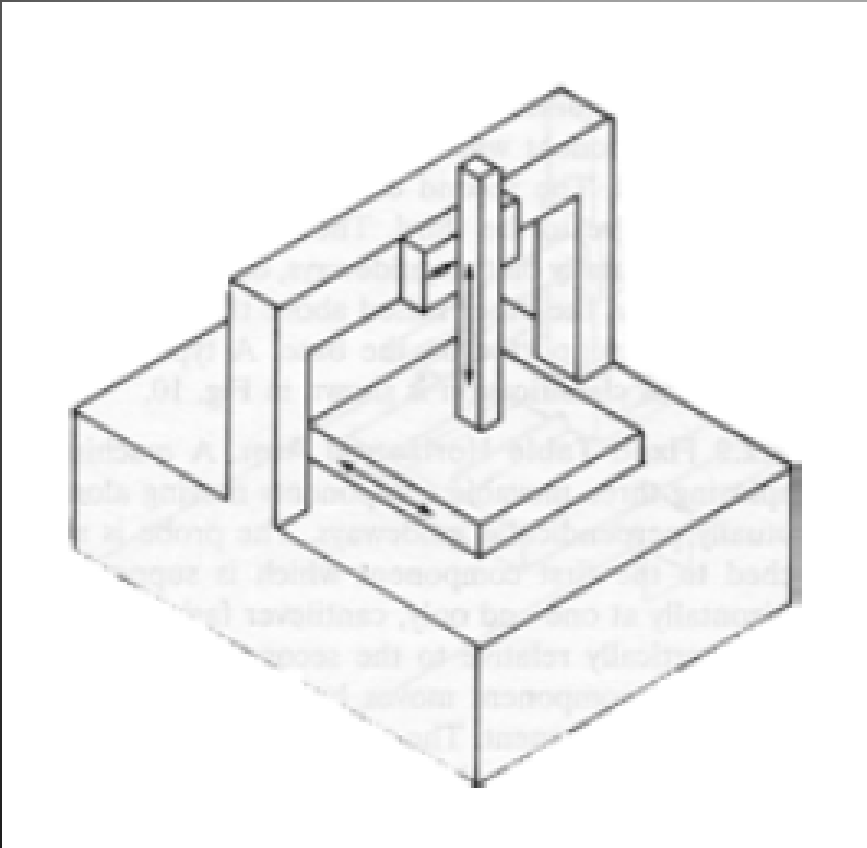



# Moving Bridge CMM( Computer Controlled)

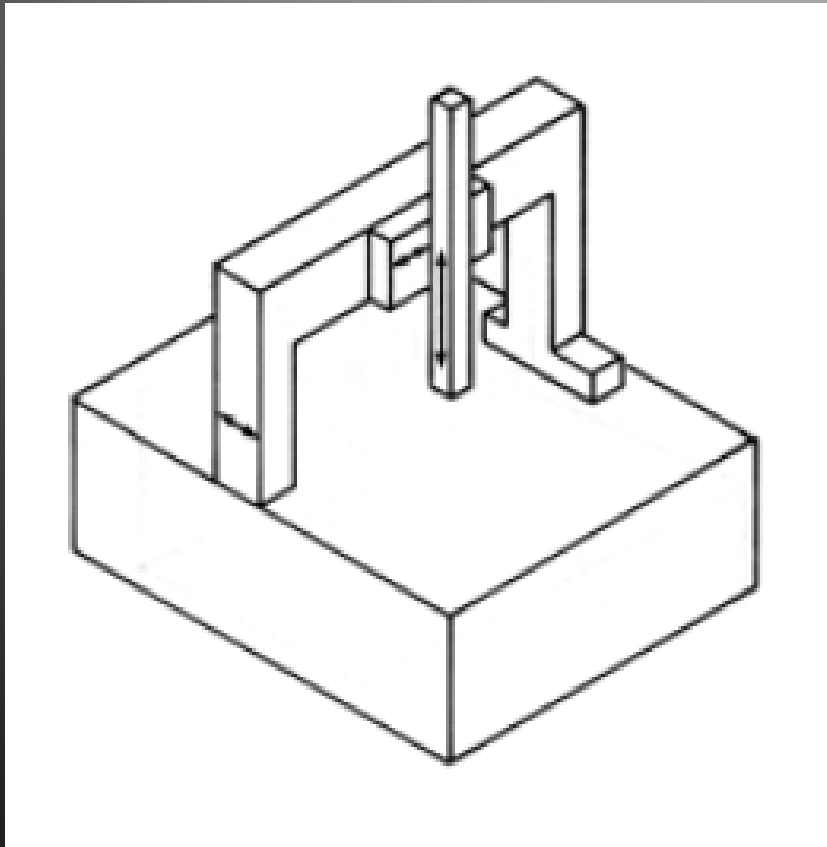

# Gantry Type CMM

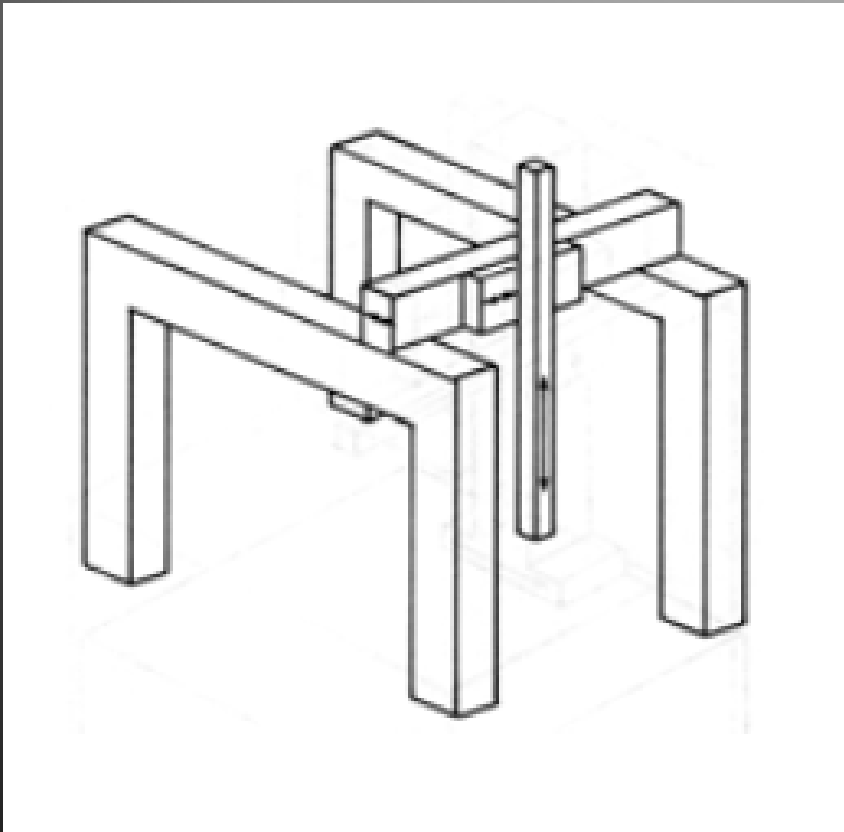

# Measuring Ranges

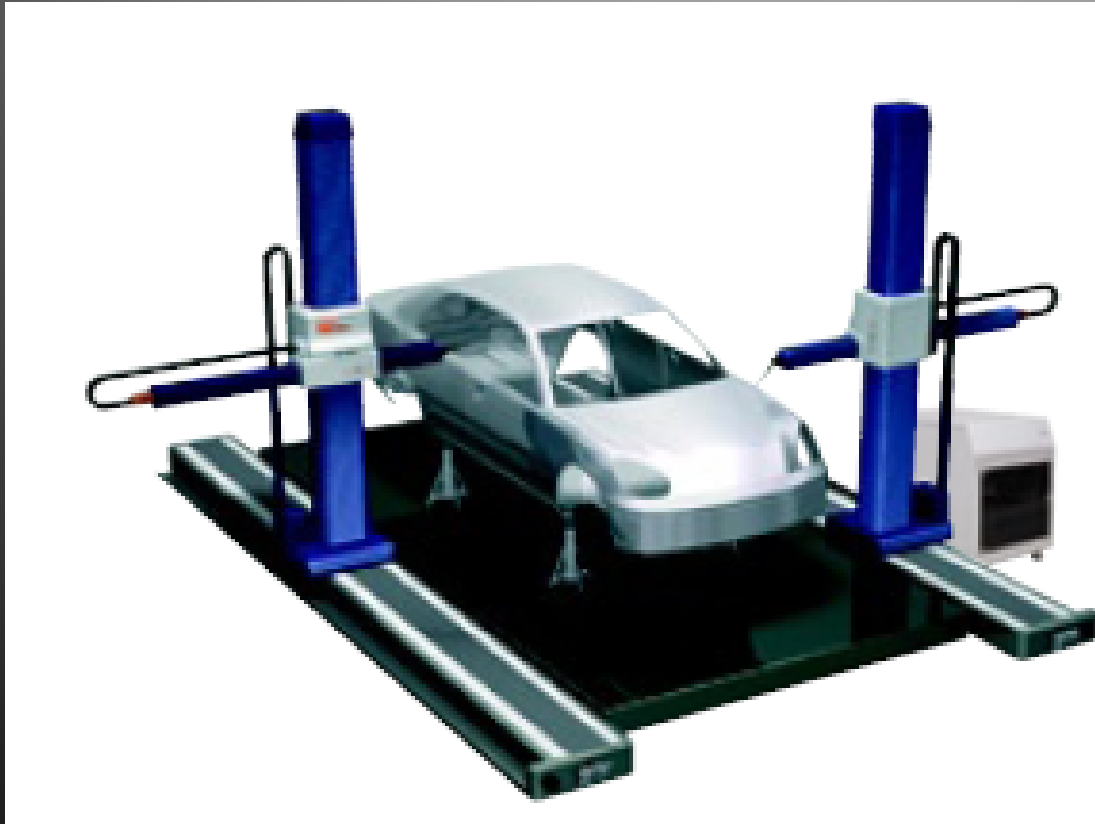

18.11" x 18.11" x 11.81"  
(460 x 460 x 300mm)  
40.20" x 32.20" x 24.21"  
( 1021 x 818 x 615mm)

- **Sources of errors in CMM measurements**
  - ▶ spatial errors
  - ▶ computational errors.
  - ▶ **Spatial errors** are errors in the measured position of a point on the surface of the Work-piece
- **Computational errors** are the errors in the estimated dimensions and form deviations of the work-piece

## Spatial Errors

- The accuracy of the components of the CMM – the guide-ways, the scales, the probe system and the qualification sphere.
- The environment in which the CMM operates – the ambient temperature, temperature gradients, humidity and vibration. •
- The probing strategy used – the magnitude and direction of the probe force, the type of probe stylus used and the measuring speed of the probe. •
- The characteristics of the work-piece – elasticity, surface roughness, hardness and the mass of the component.

## Computational errors

- The CMM software used to estimate the geometry of the work-piece.
- The precision of the computer used on the CMM.
- The number and relative position of the measured points.
- The extent to which the geometry departs from the ideal geometric form.