

REAL NUMBERS

(A) Main Concepts and Results

- Euclid's Division Lemma : Given two positive integers a and b , there exist unique integers q and r satisfying $a = bq + r$, $0 \leq r < b$.
- Euclid's Division Algorithm to obtain the HCF of two positive integers, say c and d , $c > d$.

Step 1 : Apply Euclid's division lemma to c and d , to find whole numbers q and r , such that $c = dq + r$, $0 \leq r < d$.

Step 2 : If $r = 0$, d is the HCF of c and d . If $r \neq 0$, apply the division lemma to d and r .

Step 3 : Continue the process till the remainder is zero. The divisor at this stage will be the required HCF.

- Fundamental Theorem of Arithmetic : Every composite number can be expressed as a product of primes, and this expression (factorisation) is unique, apart from the order in which the prime factors occur.
- Let p be a prime number. If p divides a^2 , then p divides a , where a is a positive integer.
- $\sqrt{2}$, $\sqrt{3}$, $\sqrt{5}$ are irrational numbers.
- The sum or difference of a rational and an irrational number is irrational.
- The product or quotient of a non-zero rational number and an irrational number is irrational.
- For any two positive integers a and b , $\text{HCF}(a, b) \times \text{LCM}(a, b) = a \times b$.

- Let $x = \frac{p}{q}$, p and q are co-prime, be a rational number whose decimal expansion terminates. Then, the prime factorisation of q is of the form $2^m \cdot 5^n$; m, n are non-negative integers.
- Let $x = \frac{p}{q}$ be a rational number such that the prime factorisation of q is not of the form $2^m \cdot 5^n$; m, n being non-negative integers. Then, x has a non-terminating repeating decimal expansion.

(B) Multiple Choice Questions

Choose the correct answer from the given four options:

Sample Question 1 : The decimal expansion of the rational number $\frac{33}{2^2 \cdot 5}$ will terminate after

- (A) one decimal place (B) two decimal places
 (C) three decimal places (D) more than 3 decimal places

Solution : Answer (B)

Sample Question 2 : Euclid's division lemma states that for two positive integers a and b , there exist unique integers q and r such that $a = bq + r$, where r must satisfy

- (A) $1 < r < b$ (B) $0 < r \leq b$
 (C) $0 \leq r < b$ (D) $0 < r < b$

Solution : Answer (C)

EXERCISE 1.1

Choose the correct answer from the given four options in the following questions:

- For some integer m , every even integer is of the form

(A) m (B) $m + 1$
 (C) $2m$ (D) $2m + 1$
- For some integer q , every odd integer is of the form

(A) q (B) $q + 1$
 (C) $2q$ (D) $2q + 1$

3. $n^2 - 1$ is divisible by 8, if n is
(A) an integer (B) a natural number
(C) an odd integer (D) an even integer
4. If the HCF of 65 and 117 is expressible in the form $65m - 117$, then the value of m is
(A) 4 (B) 2
(C) 1 (D) 3
5. The largest number which divides 70 and 125, leaving remainders 5 and 8, respectively, is
(A) 13 (B) 65
(C) 875 (D) 1750
6. If two positive integers a and b are written as
 $a = x^3y^2$ and $b = xy^3$; x, y are prime numbers, then HCF (a, b) is
(A) xy (B) xy^2 (C) x^3y^3 (D) x^2y^2
7. If two positive integers p and q can be expressed as
 $p = ab^2$ and $q = a^3b$; a, b being prime numbers, then LCM (p, q) is
(A) ab (B) a^2b^2 (C) a^3b^2 (D) a^3b^3
8. The product of a non-zero rational and an irrational number is
(A) always irrational (B) always rational
(C) rational or irrational (D) one
9. The least number that is divisible by all the numbers from 1 to 10 (both inclusive) is
(A) 10 (B) 100 (C) 504 (D) 2520
10. The decimal expansion of the rational number $\frac{14587}{1250}$ will terminate after:
(A) one decimal place (B) two decimal places
(C) three decimal places (D) four decimal places

(C) Short Answer Questions with Reasoning

Sample Question 1: The values of the remainder r , when a positive integer a is divided by 3 are 0 and 1 only. Justify your answer.

Solution : No.

According to Euclid's division lemma,

$$a = 3q + r, \text{ where } 0 \leq r < 3$$

and r is an integer. Therefore, the values of r can be 0, 1 or 2.

Sample Question 2: Can the number 6^n , n being a natural number, end with the digit 5? Give reasons.

Solution : No, because $6^n = (2 \times 3)^n = 2^n \times 3^n$, so the only primes in the factorisation of 6^n are 2 and 3, and not 5.

Hence, it cannot end with the digit 5.

EXERCISE 1.2

- Write whether every positive integer can be of the form $4q + 2$, where q is an integer. Justify your answer.
- “The product of two consecutive positive integers is divisible by 2”. Is this statement true or false? Give reasons.
- “The product of three consecutive positive integers is divisible by 6”. Is this statement true or false”? Justify your answer.
- Write whether the square of any positive integer can be of the form $3m + 2$, where m is a natural number. Justify your answer.
- A positive integer is of the form $3q + 1$, q being a natural number. Can you write its square in any form other than $3m + 1$, i.e., $3m$ or $3m + 2$ for some integer m ? Justify your answer.
- The numbers 525 and 3000 are both divisible only by 3, 5, 15, 25 and 75. What is HCF (525, 3000)? Justify your answer.
- Explain why $3 \times 5 \times 7 + 7$ is a composite number.
- Can two numbers have 18 as their HCF and 380 as their LCM? Give reasons.
- Without actually performing the long division, find if $\frac{987}{10500}$ will have terminating or non-terminating (repeating) decimal expansion. Give reasons for your answer.
- A rational number in its decimal expansion is 327.7081. What can you say about the prime factors of q , when this number is expressed in the form $\frac{p}{q}$? Give reasons.

(D) Short Answer Questions

Sample Question 1: Using Euclid's division algorithm, find which of the following pairs of numbers are co-prime:

- (i) 231, 396 (ii) 847, 2160

Solution : Let us find the HCF of each pair of numbers.

$$\begin{aligned} \text{(i)} \quad 396 &= 231 \times 1 + 165 \\ 231 &= 165 \times 1 + 66 \\ 165 &= 66 \times 2 + 33 \\ 66 &= 33 \times 2 + 0 \end{aligned}$$

Therefore, HCF = 33. Hence, numbers are not co-prime.

$$\begin{aligned} \text{(ii)} \quad 2160 &= 847 \times 2 + 466 \\ 847 &= 466 \times 1 + 381 \\ 466 &= 381 \times 1 + 85 \\ 381 &= 85 \times 4 + 41 \\ 85 &= 41 \times 2 + 3 \\ 41 &= 3 \times 13 + 2 \\ 3 &= 2 \times 1 + 1 \\ 2 &= 1 \times 2 + 0 \end{aligned}$$

Therefore, the HCF = 1. Hence, the numbers are co-prime.

Sample Question 2: Show that the square of an odd positive integer is of the form $8m + 1$, for some whole number m .

Solution: Any positive odd integer is of the form $2q + 1$, where q is a whole number.

$$\text{Therefore, } (2q + 1)^2 = 4q^2 + 4q + 1 = 4q(q + 1) + 1, \quad (1)$$

$q(q + 1)$ is either 0 or even. So, it is $2m$, where m is a whole number.

$$\text{Therefore, } (2q + 1)^2 = 4 \cdot 2m + 1 = 8m + 1. \quad [\text{From (1)}]$$

Sample Question 3: Prove that $\sqrt{2} + \sqrt{3}$ is irrational.

Solution : Let us suppose that $\sqrt{2} + \sqrt{3}$ is rational. Let $\sqrt{2} + \sqrt{3} = a$, where a is rational.

Therefore, $\sqrt{2} = a - \sqrt{3}$

Squaring on both sides, we get

$$2 = a^2 + 3 - 2a\sqrt{3}$$

Therefore, $\sqrt{3} = \frac{a^2 + 1}{2a}$, which is a contradiction as the right hand side is a rational number while $\sqrt{3}$ is irrational. Hence, $\sqrt{2} + \sqrt{3}$ is irrational.

EXERCISE 1.3

1. Show that the square of any positive integer is either of the form $4q$ or $4q + 1$ for some integer q .
2. Show that cube of any positive integer is of the form $4m$, $4m + 1$ or $4m + 3$, for some integer m .
3. Show that the square of any positive integer cannot be of the form $5q + 2$ or $5q + 3$ for any integer q .
4. Show that the square of any positive integer cannot be of the form $6m + 2$ or $6m + 5$ for any integer m .
5. Show that the square of any odd integer is of the form $4q + 1$, for some integer q .
6. If n is an odd integer, then show that $n^2 - 1$ is divisible by 8.
7. Prove that if x and y are both odd positive integers, then $x^2 + y^2$ is even but not divisible by 4.
8. Use Euclid's division algorithm to find the HCF of 441, 567, 693.
9. Using Euclid's division algorithm, find the largest number that divides 1251, 9377 and 15628 leaving remainders 1, 2 and 3, respectively.
10. Prove that $\sqrt{3} + \sqrt{5}$ is irrational.
11. Show that 12^n cannot end with the digit 0 or 5 for any natural number n .
12. On a morning walk, three persons step off together and their steps measure 40 cm, 42 cm and 45 cm, respectively. What is the minimum distance each should walk so that each can cover the same distance in complete steps?

13. Write the denominator of the rational number $\frac{257}{5000}$ in the form $2^m \times 5^n$, where m, n are non-negative integers. Hence, write its decimal expansion, without actual division.
14. Prove that $\sqrt{p} + \sqrt{q}$ is irrational, where p, q are primes.

(E) Long Answer Questions

Sample Question 1 : Show that the square of an odd positive integer can be of the form $6q + 1$ or $6q + 3$ for some integer q .

Solution : We know that any positive integer can be of the form $6m, 6m + 1, 6m + 2, 6m + 3, 6m + 4$ or $6m + 5$, for some integer m .

Thus, an odd positive integer can be of the form $6m + 1, 6m + 3$, or $6m + 5$
Thus we have:

$$(6m + 1)^2 = 36m^2 + 12m + 1 = 6(6m^2 + 2m) + 1 = 6q + 1, q \text{ is an integer}$$

$$(6m + 3)^2 = 36m^2 + 36m + 9 = 6(6m^2 + 6m + 1) + 3 = 6q + 3, q \text{ is an integer}$$

$$(6m + 5)^2 = 36m^2 + 60m + 25 = 6(6m^2 + 10m + 4) + 1 = 6q + 1, q \text{ is an integer.}$$

Thus, the square of an odd positive integer can be of the form $6q + 1$ or $6q + 3$.

EXERCISE 1.4

1. Show that the cube of a positive integer of the form $6q + r$, q is an integer and $r = 0, 1, 2, 3, 4, 5$ is also of the form $6m + r$.
2. Prove that one and only one out of $n, n + 2$ and $n + 4$ is divisible by 3, where n is any positive integer.
3. Prove that one of any three consecutive positive integers must be divisible by 3.
4. For any positive integer n , prove that $n^3 - n$ is divisible by 6.
5. Show that one and only one out of $n, n + 4, n + 8, n + 12$ and $n + 16$ is divisible by 5, where n is any positive integer.

[Hint: Any positive integer can be written in the form $5q, 5q+1, 5q+2, 5q+3, 5q+4$].

POLYNOMIALS

(A) Main Concepts and Results

- Geometrical meaning of zeroes of a polynomial: The zeroes of a polynomial $p(x)$ are precisely the x -coordinates of the points where the graph of $y = p(x)$ intersects the x -axis.
- Relation between the zeroes and coefficients of a polynomial: If α and β are the zeroes of a quadratic polynomial $ax^2 + bx + c$, then $\alpha + \beta = -\frac{b}{a}$, $\alpha\beta = \frac{c}{a}$.
- If α , β and γ are the zeroes of a cubic polynomial $ax^3 + bx^2 + cx + d$, then $\alpha + \beta + \gamma = -\frac{b}{a}$, $\alpha\beta + \beta\gamma + \gamma\alpha = \frac{c}{a}$ and $\alpha\beta\gamma = -\frac{d}{a}$.
- The division algorithm states that given any polynomial $p(x)$ and any non-zero polynomial $g(x)$, there are polynomials $q(x)$ and $r(x)$ such that $p(x) = g(x)q(x) + r(x)$, where $r(x) = 0$ or degree $r(x) <$ degree $g(x)$.

(B) Multiple Choice Questions

Choose the correct answer from the given four options:

Sample Question 1: If one zero of the quadratic polynomial $x^2 + 3x + k$ is 2, then the value of k is

- (A) 10 (B) -10 (C) 5 (D) -5

Solution : Answer (B)

Sample Question 2: Given that two of the zeroes of the cubic polynomial $ax^3 + bx^2 + cx + d$ are 0, the third zero is

- (A) $\frac{-b}{a}$ (B) $\frac{b}{a}$ (C) $\frac{c}{a}$ (D) $-\frac{d}{a}$

Solution : Answer (A). [**Hint:** Because if third zero is α , sum of the zeroes

$$= \alpha + 0 + 0 = \frac{-b}{a}]$$

EXERCISE 2.1

Choose the correct answer from the given four options in the following questions:

1. If one of the zeroes of the quadratic polynomial $(k-1)x^2 + kx + 1$ is -3 , then the value of k is

- (A) $\frac{4}{3}$ (B) $\frac{-4}{3}$ (C) $\frac{2}{3}$ (D) $\frac{-2}{3}$

2. A quadratic polynomial, whose zeroes are -3 and 4 , is

- (A) $x^2 - x + 12$ (B) $x^2 + x + 12$
 (C) $\frac{x^2}{2} - \frac{x}{2} - 6$ (D) $2x^2 + 2x - 24$

3. If the zeroes of the quadratic polynomial $x^2 + (a+1)x + b$ are 2 and -3 , then

- (A) $a = -7, b = -1$ (B) $a = 5, b = -1$
 (C) $a = 2, b = -6$ (D) $a = 0, b = -6$

4. The number of polynomials having zeroes as -2 and 5 is

- (A) 1 (B) 2 (C) 3 (D) more than 3

5. Given that one of the zeroes of the cubic polynomial $ax^3 + bx^2 + cx + d$ is zero, the product of the other two zeroes is

- (A) $-\frac{c}{a}$ (B) $\frac{c}{a}$ (C) 0 (D) $-\frac{b}{a}$

6. If one of the zeroes of the cubic polynomial $x^3 + ax^2 + bx + c$ is -1 , then the product of the other two zeroes is

- (A) $b - a + 1$ (B) $b - a - 1$ (C) $a - b + 1$ (D) $a - b - 1$

7. The zeroes of the quadratic polynomial $x^2 + 99x + 127$ are
 (A) both positive (B) both negative
 (C) one positive and one negative (D) both equal
8. The zeroes of the quadratic polynomial $x^2 + kx + k$, $k \neq 0$,
 (A) cannot both be positive (B) cannot both be negative
 (C) are always unequal (D) are always equal
9. If the zeroes of the quadratic polynomial $ax^2 + bx + c$, $c \neq 0$ are equal, then
 (A) c and a have opposite signs (B) c and b have opposite signs
 (C) c and a have the same sign (D) c and b have the same sign
10. If one of the zeroes of a quadratic polynomial of the form $x^2 + ax + b$ is the negative of the other, then it
 (A) has no linear term and the constant term is negative.
 (B) has no linear term and the constant term is positive.
 (C) can have a linear term but the constant term is negative.
 (D) can have a linear term but the constant term is positive.
11. Which of the following is not the graph of a quadratic polynomial?

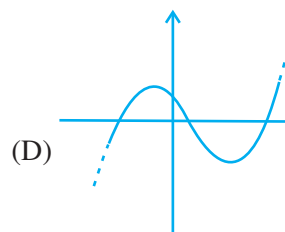
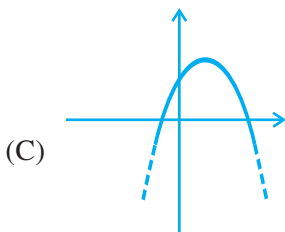
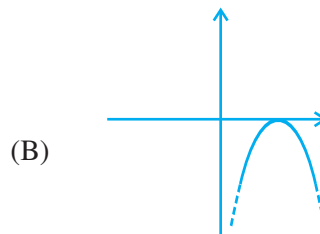
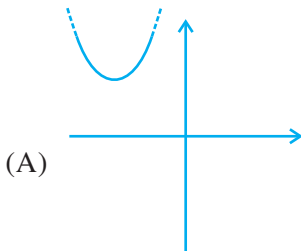

(C) Short Answer Questions with Reasoning

Sample Question 1: Can $x - 1$ be the remainder on division of a polynomial $p(x)$ by $2x + 3$? Justify your answer.

Solution : No, since degree $(x - 1) = 1 =$ degree $(2x + 3)$.

Sample Question 2: Is the following statement True or False? Justify your answer.

If the zeroes of a quadratic polynomial $ax^2 + bx + c$ are both negative, then a , b and c all have the same sign.

Solution : True, because $-\frac{b}{a} =$ sum of the zeroes < 0 , so that $\frac{b}{a} > 0$. Also the product

of the zeroes $= \frac{c}{a} > 0$.

EXERCISE 2.2

1. Answer the following and justify:
 - (i) Can $x^2 - 1$ be the quotient on division of $x^6 + 2x^3 + x - 1$ by a polynomial in x of degree 5?
 - (ii) What will the quotient and remainder be on division of $ax^2 + bx + c$ by $px^3 + qx^2 + rx + s$, $p \neq 0$?
 - (iii) If on division of a polynomial $p(x)$ by a polynomial $g(x)$, the quotient is zero, what is the relation between the degrees of $p(x)$ and $g(x)$?
 - (iv) If on division of a non-zero polynomial $p(x)$ by a polynomial $g(x)$, the remainder is zero, what is the relation between the degrees of $p(x)$ and $g(x)$?
 - (v) Can the quadratic polynomial $x^2 + kx + k$ have equal zeroes for some odd integer $k > 1$?
2. Are the following statements 'True' or 'False'? Justify your answers.
 - (i) If the zeroes of a quadratic polynomial $ax^2 + bx + c$ are both positive, then a , b and c all have the same sign.
 - (ii) If the graph of a polynomial intersects the x -axis at only one point, it cannot be a quadratic polynomial.
 - (iii) If the graph of a polynomial intersects the x -axis at exactly two points, it need not be a quadratic polynomial.
 - (iv) If two of the zeroes of a cubic polynomial are zero, then it does not have linear and constant terms.

- (v) If all the zeroes of a cubic polynomial are negative, then all the coefficients and the constant term of the polynomial have the same sign.
- (vi) If all three zeroes of a cubic polynomial $x^3 + ax^2 - bx + c$ are positive, then at least one of a , b and c is non-negative.
- (vii) The only value of k for which the quadratic polynomial $kx^2 + x + k$ has equal zeros is $\frac{1}{2}$

(D) Short Answer Questions

Sample Question 1: Find the zeroes of the polynomial $x^2 + \frac{1}{6}x - 2$, and verify the relation between the coefficients and the zeroes of the polynomial.

Solution : $x^2 + \frac{1}{6}x - 2 = \frac{1}{6} (6x^2 + x - 12) = \frac{1}{6} [6x^2 + 9x - 8x - 12]$

$$= \frac{1}{6} [3x(2x + 3) - 4(2x + 3)] = \frac{1}{6} (3x - 4)(2x + 3)$$

Hence, $\frac{4}{3}$ and $-\frac{3}{2}$ are the zeroes of the given polynomial.

The given polynomial is $x^2 + \frac{1}{6}x - 2$.

The sum of zeroes = $\frac{4}{3} + -\frac{3}{2} = \frac{-1}{6} = -\frac{\text{Coefficient of } x}{\text{Coefficient of } x^2}$ and

the product of zeroes = $\frac{4}{3} \times \frac{-3}{2} = -2 = \frac{\text{Constant term}}{\text{Coefficient of } x^2}$

EXERCISE 2.3

Find the zeroes of the following polynomials by factorisation method and verify the relations between the zeroes and the coefficients of the polynomials:

1. $4x^2 - 3x - 1$

2. $3x^2 + 4x - 4$

3. $5t^2 + 12t + 7$

4. $t^3 - 2t^2 - 15t$

5. $2x^2 + \frac{7}{2}x + \frac{3}{4}$

6. $4x^2 + 5\sqrt{2}x - 3$

7. $2s^2 - (1 + 2\sqrt{2})s + \sqrt{2}$

8. $v^2 + 4\sqrt{3}v - 15$

9. $y^2 + \frac{3}{2}\sqrt{5}y - 5$

10. $7y^2 - \frac{11}{3}y - \frac{2}{3}$

(E) Long Answer Questions

Sample Question 1: Find a quadratic polynomial, the sum and product of whose zeroes are $\sqrt{2}$ and $-\frac{3}{2}$, respectively. Also find its zeroes.

Solution : A quadratic polynomial, the sum and product of whose zeroes are

$\sqrt{2}$ and $-\frac{3}{2}$ is $x^2 - \sqrt{2}x - \frac{3}{2}$

$$\begin{aligned} x^2 - \sqrt{2}x - \frac{3}{2} &= \frac{1}{2} [2x^2 - 2\sqrt{2}x - 3] \\ &= \frac{1}{2} [2x^2 + \sqrt{2}x - 3\sqrt{2}x - 3] \\ &= \frac{1}{2} [\sqrt{2}x(\sqrt{2}x + 1) - 3(\sqrt{2}x + 1)] \\ &= \frac{1}{2} [\sqrt{2}x + 1][\sqrt{2}x - 3] \end{aligned}$$

Hence, the zeroes are $-\frac{1}{\sqrt{2}}$ and $\frac{3}{\sqrt{2}}$.

Sample Question 2: If the remainder on division of $x^3 + 2x^2 + kx + 3$ by $x - 3$ is 21, find the quotient and the value of k . Hence, find the zeroes of the cubic polynomial $x^3 + 2x^2 + kx - 18$.

Solution : Let $p(x) = x^3 + 2x^2 + kx + 3$

Then, $p(3) = 3^3 + 2 \times 3^2 + 3k + 3 = 21$

i.e., $3k = -27$

i.e., $k = -9$

Hence, the given polynomial will become $x^3 + 2x^2 - 9x + 3$.

Now, $(x - 3) x^3 + 2x^2 - 9x + 3(x^2 + 5x + 6$

$$\begin{array}{r} x^3 - 3x^2 \\ \hline 5x^2 - 9x + 3 \\ 5x^2 - 15x \\ \hline 6x + 3 \\ 6x - 18 \\ \hline 21 \end{array}$$

So, $x^3 + 2x^2 - 9x + 3 = (x^2 + 5x + 6)(x - 3) + 21$

i.e., $x^3 + 2x^2 - 9x - 18 = (x - 3)(x^2 + 5x + 6)$

$$= (x - 3)(x + 2)(x + 3)$$

So, the zeroes of $x^3 + 2x^2 + kx - 18$ are 3, -2, -3.

EXERCISE 2.4

- For each of the following, find a quadratic polynomial whose sum and product respectively of the zeroes are as given. Also find the zeroes of these polynomials by factorisation.

(i) $\frac{-8}{3}, \frac{4}{3}$

(ii) $\frac{21}{8}, \frac{5}{16}$

(iii) $-2\sqrt{3}, -9$

(iv) $\frac{-3}{2\sqrt{5}}, -\frac{1}{2}$

- Given that the zeroes of the cubic polynomial $x^3 - 6x^2 + 3x + 10$ are of the form a , $a + b$, $a + 2b$ for some real numbers a and b , find the values of a and b as well as the zeroes of the given polynomial.

3. Given that $\sqrt{2}$ is a zero of the cubic polynomial $6x^3 + \sqrt{2}x^2 - 10x - 4\sqrt{2}$, find its other two zeroes.
4. Find k so that $x^2 + 2x + k$ is a factor of $2x^4 + x^3 - 14x^2 + 5x + 6$. Also find all the zeroes of the two polynomials.
5. Given that $x - \sqrt{5}$ is a factor of the cubic polynomial $x^3 - 3\sqrt{5}x^2 + 13x - 3\sqrt{5}$, find all the zeroes of the polynomial.
6. For which values of a and b , are the zeroes of $q(x) = x^3 + 2x^2 + a$ also the zeroes of the polynomial $p(x) = x^5 - x^4 - 4x^3 + 3x^2 + 3x + b$? Which zeroes of $p(x)$ are not the zeroes of $q(x)$?

PAIR OF LINEAR EQUATIONS IN TWO VARIABLES

(A) Main Concepts and Results

- Two linear equations in the same two variables are said to form a pair of linear equations in two variables.

- The most general form of a pair of linear equations is

$$a_1x + b_1y + c_1 = 0$$

$$a_2x + b_2y + c_2 = 0,$$

where $a_1, a_2, b_1, b_2, c_1, c_2$ are real numbers, such that $a_1^2 + b_1^2 \neq 0, a_2^2 + b_2^2 \neq 0$.

- A pair of linear equations is consistent if it has a solution – either a unique or infinitely many.

In case of infinitely many solutions, the pair of linear equations is also said to be dependent. Thus, in this case, the pair of linear equations is dependent and consistent.

- A pair of linear equations is inconsistent, if it has no solution.
- Let a pair of linear equations in two variables be $a_1x + b_1y + c_1 = 0$ and $a_2x + b_2y + c_2 = 0$.

(I) If $\frac{a_1}{a_2} \neq \frac{b_1}{b_2}$, then

- (i) the pair of linear equations is consistent,
 - (ii) the graph will be a pair of lines intersecting at a unique point, which is the solution of the pair of equations.
- (II) If $\frac{a_1}{a_2} = \frac{b_1}{b_2} \neq \frac{c_1}{c_2}$, then
- (i) the pair of linear equations is inconsistent,
 - (ii) the graph will be a pair of parallel lines and so the pair of equations will have no solution.
- (III) If $\frac{a_1}{a_2} = \frac{b_1}{b_2} = \frac{c_1}{c_2}$, then
- (i) the pair of linear equations is dependent, and consistent,
 - (ii) the graph will be a pair of coincident lines. Each point on the lines will be a solution, and so the pair of equations will have infinitely many solutions.
- A pair of linear equations can be solved algebraically by any of the following methods:
 - (i) Substitution Method
 - (ii) Elimination Method
 - (iii) Cross- multiplication Method
 - The pair of linear equations can also be solved geometrically/graphically.

(B) Multiple Choice Questions

Choose the correct answer from the given four options:

Sample Question 1 : The pair of equations $5x - 15y = 8$ and $3x - 9y = \frac{24}{5}$ has

- (A) one solution
- (B) two solutions
- (C) infinitely many solutions
- (D) no solution

Solution : Answer (C)

Sample Question 2 : The sum of the digits of a two-digit number is 9. If 27 is added to it, the digits of the number get reversed. The number is

- (A) 25 (B) 72 (C) 63 (D) 36

Solution : Answer (D)

EXERCISE 3.1

Choose the correct answer from the given four options:

1. Graphically, the pair of equations

$$6x - 3y + 10 = 0$$

$$2x - y + 9 = 0$$

represents two lines which are

- (A) intersecting at exactly one point. (B) intersecting at exactly two points.
 (C) coincident. (D) parallel.
2. The pair of equations $x + 2y + 5 = 0$ and $-3x - 6y + 1 = 0$ have
 (A) a unique solution (B) exactly two solutions
 (C) infinitely many solutions (D) no solution
3. If a pair of linear equations is consistent, then the lines will be
 (A) parallel (B) always coincident
 (C) intersecting or coincident (D) always intersecting
4. The pair of equations $y = 0$ and $y = -7$ has
 (A) one solution (B) two solutions
 (C) infinitely many solutions (D) no solution
5. The pair of equations $x = a$ and $y = b$ graphically represents lines which are
 (A) parallel (B) intersecting at (b, a)
 (C) coincident (D) intersecting at (a, b)
6. For what value of k , do the equations $3x - y + 8 = 0$ and $6x - ky = -16$ represent coincident lines?
 (A) $\frac{1}{2}$ (B) $-\frac{1}{2}$ (C) 2 (D) -2

7. If the lines given by $3x + 2ky = 2$ and $2x + 5y + 1 = 0$ are parallel, then the value of k is
- (A) $\frac{-5}{4}$ (B) $\frac{2}{5}$ (C) $\frac{15}{4}$ (D) $\frac{3}{2}$
8. The value of c for which the pair of equations $cx - y = 2$ and $6x - 2y = 3$ will have infinitely many solutions is
- (A) 3 (B) -3 (C) -12 (D) no value
9. One equation of a pair of dependent linear equations is $-5x + 7y = 2$. The second equation can be
- (A) $10x + 14y + 4 = 0$ (B) $-10x - 14y + 4 = 0$
(C) $-10x + 14y + 4 = 0$ (D) $10x - 14y = -4$
10. A pair of linear equations which has a unique solution $x = 2, y = -3$ is
- (A) $x + y = -1$ (B) $2x + 5y = -11$
 $2x - 3y = -5$ $4x + 10y = -22$
(C) $2x - y = 1$ (D) $x - 4y - 14 = 0$
 $3x + 2y = 0$ $5x - y - 13 = 0$
11. If $x = a, y = b$ is the solution of the equations $x - y = 2$ and $x + y = 4$, then the values of a and b are, respectively
- (A) 3 and 5 (B) 5 and 3
(C) 3 and 1 (D) -1 and -3
12. Aruna has only Re 1 and Rs 2 coins with her. If the total number of coins that she has is 50 and the amount of money with her is Rs 75, then the number of Re 1 and Rs 2 coins are, respectively
- (A) 35 and 15 (B) 35 and 20
(C) 15 and 35 (D) 25 and 25
13. The father's age is six times his son's age. Four years hence, the age of the father will be four times his son's age. The present ages, in years, of the son and the father are, respectively
- (A) 4 and 24 (B) 5 and 30
(C) 6 and 36 (D) 3 and 24

(C) Short Answer Questions with Reasoning**Sample Question 1:** Is it true to say that the pair of equations

$$-x + 2y + 2 = 0 \text{ and } \frac{1}{2}x - \frac{1}{4}y - 1 = 0$$

has a unique solution? Justify your answer.

Solution : Yes.

$$\text{Here, } \frac{a_1}{a_2} = \frac{-1}{\frac{1}{2}} = -2, \quad \frac{b_1}{b_2} = \frac{2}{-\frac{1}{4}} = -8$$

As $\frac{a_1}{a_2} \neq \frac{b_1}{b_2}$, the pair of equations has a unique solution.

Sample Question 2 : Do the equations $4x + 3y - 1 = 5$ and $12x + 9y = 15$ represent a pair of coincident lines? Justify your answer.**Solution :** No.

We may rewrite the equations as

$$4x + 3y = 6$$

$$12x + 9y = 15$$

$$\text{Here, } \frac{a_1}{a_2} = \frac{1}{3}, \quad \frac{b_1}{b_2} = \frac{1}{3} \text{ and } \frac{c_1}{c_2} = \frac{2}{5}$$

As $\frac{a_1}{a_2} = \frac{b_1}{b_2} \neq \frac{c_1}{c_2}$, the given equations do not represent a pair of coincident lines.

Sample Question 3 : Is the pair of equations $x + 2y - 3 = 0$ and $6y + 3x - 9 = 0$ consistent? Justify your answer.**Solution :** Yes.

Rearranging the terms in the equations, we get

$$x + 2y - 3 = 0$$

$$3x + 6y - 9 = 0$$

Here, $\frac{a_1}{a_2} = \frac{1}{3}$, $\frac{b_1}{b_2} = \frac{1}{3}$, $\frac{c_1}{c_2} = \frac{1}{3}$. As $\frac{a_1}{a_2} = \frac{b_1}{b_2} = \frac{c_1}{c_2}$, the pair of equations is consistent.

EXERCISE 3.2

1. Do the following pair of linear equations have no solution? Justify your answer.

(i) $2x + 4y = 3$

(ii) $x = 2y$

$12y + 6x = 6$

$y = 2x$

(iii) $3x + y - 3 = 0$

$2x + \frac{2}{3}y = 2$

2. Do the following equations represent a pair of coincident lines? Justify your answer.

(i) $3x + \frac{1}{7}y = 3$

(ii) $-2x - 3y = 1$

$7x + 3y = 7$

$6y + 4x = -2$

(iii) $\frac{x}{2} + y + \frac{2}{5} = 0$

$4x + 8y + \frac{5}{16} = 0$

3. Are the following pair of linear equations consistent? Justify your answer.

(i) $-3x - 4y = 12$

(ii) $\frac{3}{5}x - y = \frac{1}{2}$

$4y + 3x = 12$

$\frac{1}{5}x - 3y = \frac{1}{6}$

(iii) $2ax + by = a$

(iv) $x + 3y = 11$

$4ax + 2by - 2a = 0; a, b \neq 0$

$2(2x + 6y) = 22$

4. For the pair of equations

$\lambda x + 3y = -7$

$2x + 6y = 14$

to have infinitely many solutions, the value of λ should be 1. Is the statement true? Give reasons.

5. For all real values of c , the pair of equations

$$x - 2y = 8$$

$$5x - 10y = c$$

have a unique solution. Justify whether it is true or false.

6. The line represented by $x = 7$ is parallel to the x -axis. Justify whether the statement is true or not.

(D) Short Answer Questions

Sample Question 1 : For which values of p and q , will the following pair of linear equations have infinitely many solutions?

$$4x + 5y = 2$$

$$(2p + 7q)x + (p + 8q)y = 2q - p + 1.$$

Solution :

$$\text{Here, } \frac{a_1}{a_2} = \frac{4}{2p+7q}$$

$$\frac{b_1}{b_2} = \frac{5}{p+8q}$$

$$\frac{c_1}{c_2} = \frac{2}{2q-p+1}$$

For a pair of linear equations to have infinitely many solutions

$$\frac{a_1}{a_2} = \frac{b_1}{b_2} = \frac{c_1}{c_2}$$

$$\text{So, } \frac{4}{2p+7q} = \frac{5}{p+8q} = \frac{2}{2q-p+1}$$

$$\text{So, } \frac{4}{2p+7q} = \frac{5}{p+8q} \text{ and } \frac{4}{2p+7q} = \frac{2}{2q-p+1}$$

$$\text{i.e., } 4p + 32q = 10p + 35q \text{ and } 8q - 4p + 4 = 4p + 14q$$

$$\text{i.e., } 6p + 3q = 0 \quad \text{and } 8p + 6q = 4$$

$$\text{i.e., } q = -2p \quad (1) \quad \text{and } 4p + 3q = 2 \quad (2)$$

Substituting the value of q obtained from Equation(1) in Equation(2), we get

$$4p - 6p = 2$$

$$\text{or } p = -1$$

Substituting the value of p in Equation (1), we get

$$q = 2$$

So, for $p = -1$, $q = 2$, the given pair of linear equations will have infinitely many solutions.

Sample Question 2: Solve the following pair of linear equations:

$$21x + 47y = 110$$

$$47x + 21y = 162$$

Solution: We have

$$21x + 47y = 110 \quad (1)$$

$$47x + 21y = 162 \quad (2)$$

Multiplying Equation (1) by 47 and Equation (2) by 21, we get

$$987x + 2209y = 5170 \quad (3)$$

$$987x + 441y = 3402 \quad (4)$$

Subtracting Equation (4) from Equation (3), we get

$$1768y = 1768$$

$$\text{or } y = 1$$

Substituting the value of y in Equation (1), we get

$$21x + 47 = 110$$

$$\text{or } 21x = 63$$

$$\text{or } x = 3$$

$$\text{So, } x = 3, y = 1$$

Alternative Solution: We have

$$21x + 47y = 110 \quad (1)$$

$$47x + 21y = 162 \quad (2)$$

Adding Equations (1) and (2), we have

$$68x + 68y = 272$$

or $x + y = 4 \quad (5)$

Subtracting Equation (1) from Equation (2), we have

$$26x - 26y = 52$$

or $x - y = 2 \quad (6)$

On adding and subtracting Equations (5) and (6), we get

$$x = 3, \quad y = 1$$

Sample Question 3 : Draw the graphs of the pair of linear equations $x - y + 2 = 0$ and $4x - y - 4 = 0$. Calculate the area of the triangle formed by the lines so drawn and the x -axis.

Solution :

For drawing the graphs of the given equations, we find two solutions of each of the equations, which are given in Table 3.1

Table 3.1

x	0	-2	x	0	1
$y = x + 2$	2	0	$y = 4x - 4$	-4	0

Plot the points A (0, 2), B (-2, 0), P (0, -4) and Q (1, 0) on the graph paper, and join the points to form the lines AB and PQ as shown in Fig 3.1

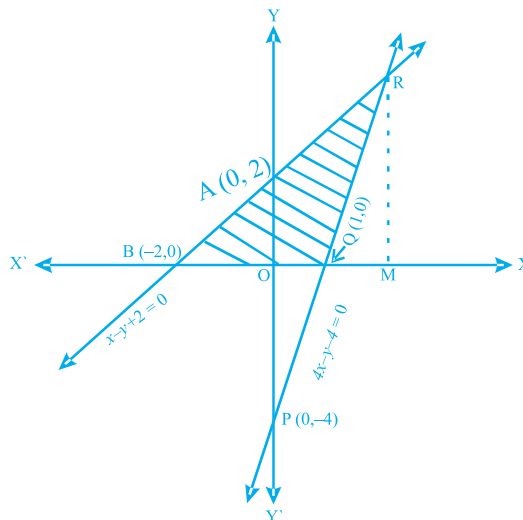

Fig. 3.1

We observe that there is a point R (2, 4) common to both the lines AB and PQ. The triangle formed by these lines and the x -axis is BQR.

The vertices of this triangle are B (-2, 0), Q (1, 0) and R (2, 4).

We know that;

$$\text{Area of triangle} = \frac{1}{2} \text{Base} \times \text{Altitude}$$

Here, Base = BQ = BO + OQ = 2 + 1 = 3 units.

Altitude = RM = Ordinate of R = 4 units.

$$\text{So, area of } \Delta \text{ BQR} = \frac{1}{2} \times 3 \times 4 = 6 \text{ sq. units.}$$

EXERCISE 3.3

1. For which value(s) of λ , do the pair of linear equations

$$\lambda x + y = \lambda^2 \text{ and } x + \lambda y = 1 \quad \text{have}$$

- (i) no solution?
 - (ii) infinitely many solutions?
 - (iii) a unique solution?
2. For which value(s) of k will the pair of equations
- $$kx + 3y = k - 3$$
- $$12x + ky = k$$
- have no solution?
3. For which values of a and b , will the following pair of linear equations have infinitely many solutions?

$$x + 2y = 1$$

$$(a - b)x + (a + b)y = a + b - 2$$

4. Find the value(s) of p in (i) to (iv) and p and q in (v) for the following pair of equations:

- (i) $3x - y - 5 = 0$ and $6x - 2y - p = 0$,
if the lines represented by these equations are parallel.

- (ii) $-x + py = 1$ and $px - y = 1$,
if the pair of equations has no solution.
- (iii) $-3x + 5y = 7$ and $2px - 3y = 1$,
if the lines represented by these equations are intersecting at a unique point.
- (iv) $2x + 3y - 5 = 0$ and $px - 6y - 8 = 0$,
if the pair of equations has a unique solution.
- (v) $2x + 3y = 7$ and $2px + py = 28 - qy$,
if the pair of equations have infinitely many solutions.
5. Two straight paths are represented by the equations $x - 3y = 2$ and $-2x + 6y = 5$. Check whether the paths cross each other or not.
6. Write a pair of linear equations which has the unique solution $x = -1$, $y = 3$. How many such pairs can you write?
7. If $2x + y = 23$ and $4x - y = 19$, find the values of $5y - 2x$ and $\frac{y}{x} - 2$.
8. Find the values of x and y in the following rectangle [see Fig. 3.2].

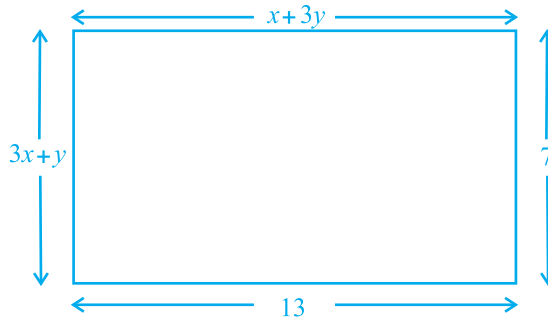

Fig. 3.2

9. Solve the following pairs of equations:
- (i) $x + y = 3.3$
- (ii) $\frac{x}{3} + \frac{y}{4} = 4$
- $\frac{0.6}{3x-2y} = -1, \quad 3x-2y \neq 0$
- $\frac{5x}{6} - \frac{y}{8} = 4$

(iii) $4x + \frac{6}{y} = 15$

$6x - \frac{8}{y} = 14, y \neq 0$

(v) $43x + 67y = -24$

$67x + 43y = 24$

(vii) $\frac{2xy}{x+y} = \frac{3}{2}$

$\frac{xy}{2x-y} = \frac{-3}{10}, \quad x+y \neq 0, 2x-y \neq 0$

(iv) $\frac{1}{2x} - \frac{1}{y} = -1$

$\frac{1}{x} + \frac{1}{2y} = 8, \quad x, y \neq 0$

(vi) $\frac{x}{a} + \frac{y}{b} = a + b$

$\frac{x}{a^2} + \frac{y}{b^2} = 2, \quad a, b \neq 0$

10. Find the solution of the pair of equations $\frac{x}{10} + \frac{y}{5} - 1 = 0$ and $\frac{x}{8} + \frac{y}{6} = 15$.

Hence, find λ , if $y = \lambda x + 5$.

11. By the graphical method, find whether the following pair of equations are consistent or not. If consistent, solve them.

(i) $3x + y + 4 = 0$

(ii) $x - 2y = 6$

$6x - 2y + 4 = 0$

$3x - 6y = 0$

(iii) $x + y = 3$

$3x + 3y = 9$

12. Draw the graph of the pair of equations $2x + y = 4$ and $2x - y = 4$. Write the vertices of the triangle formed by these lines and the y -axis. Also find the area of this triangle.
13. Write an equation of a line passing through the point representing solution of the pair of linear equations $x + y = 2$ and $2x - y = 1$. How many such lines can we find?
14. If $x + 1$ is a factor of $2x^3 + ax^2 + 2bx + 1$, then find the values of a and b given that $2a - 3b = 4$.
15. The angles of a triangle are x , y and 40° . The difference between the two angles x and y is 30° . Find x and y .

16. Two years ago, Salim was thrice as old as his daughter and six years later, he will be four years older than twice her age. How old are they now?
17. The age of the father is twice the sum of the ages of his two children. After 20 years, his age will be equal to the sum of the ages of his children. Find the age of the father.
18. Two numbers are in the ratio 5 : 6. If 8 is subtracted from each of the numbers, the ratio becomes 4 : 5. Find the numbers.
19. There are some students in the two examination halls A and B. To make the number of students equal in each hall, 10 students are sent from A to B. But if 20 students are sent from B to A, the number of students in A becomes double the number of students in B. Find the number of students in the two halls.
20. A shopkeeper gives books on rent for reading. She takes a fixed charge for the first two days, and an additional charge for each day thereafter. Latika paid Rs 22 for a book kept for six days, while Anand paid Rs 16 for the book kept for four days. Find the fixed charges and the charge for each extra day.
21. In a competitive examination, one mark is awarded for each correct answer while $\frac{1}{2}$ mark is deducted for every wrong answer. Jayanti answered 120 questions and got 90 marks. How many questions did she answer correctly?
22. The angles of a cyclic quadrilateral ABCD are
 $\angle A = (6x + 10)^\circ$, $\angle B = (5x)^\circ$
 $\angle C = (x + y)^\circ$, $\angle D = (3y - 10)^\circ$
Find x and y , and hence the values of the four angles.

(E) Long Answer Questions

Sample Question 1 : Draw the graphs of the lines $x = -2$ and $y = 3$. Write the vertices of the figure formed by these lines, the x -axis and the y -axis. Also, find the area of the figure.

Solution :

We know that the graph of $x = -2$ is a line parallel to y -axis at a distance of 2 units to the left of it.

So, the line l is the graph of $x = -2$ [see Fig. 3.3]

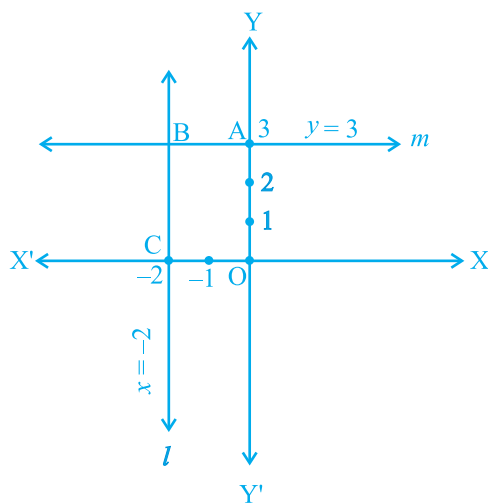

Fig. 3.3

The graph of $y = 3$ is a line parallel to the x -axis at a distance of 3 units above it.

So, the line m is the graph of $y = 3$.

The figure enclosed by the lines $x = -2$, $y = 3$, the x -axis and the y -axis is $OABC$, which is a rectangle. (Why?)

A is a point on the y -axis at a distance of 3 units above the x -axis. So, the coordinates of A are $(0, 3)$;

C is a point on the x -axis at a distance of 2 units to the left of y -axis. So, the coordinates of C are $(-2, 0)$

B is the solution of the pair of equations $x = -2$ and $y = 3$. So, the coordinates of B are $(-2, 3)$

So, the vertices of the rectangle $OABC$ are $O(0, 0)$, $A(0, 3)$, $B(-2, 3)$, $C(-2, 0)$

The length and breadth of this rectangle are 2 units and 3 units, respectively.

As the area of a rectangle = length \times breadth,

the area of rectangle $OABC = 2 \times 3 = 6$ sq. units.

Sample Question 2: Determine, algebraically, the vertices of the triangle formed by the lines

$$5x - y = 5, \quad x + 2y = 1 \text{ and } 6x + y = 17.$$

Solution:

The vertex of a triangle is the common solution of the two equations forming its two sides. So, solving the given equations pairwise will give the vertices of the triangle.

From the given equations, we will have the following three pairs of equations:

$$5x - y = 5 \quad \text{and} \quad x + 2y = 1$$

$$x + 2y = 1 \quad \text{and} \quad 6x + y = 17$$

$$5x - y = 5 \quad \text{and} \quad 6x + y = 17$$

Solving the pair of equations

$$5x - y = 5$$

$$x + 2y = 1$$

we get, $x = 1, y = 0$

So, one vertex of the triangle is $(1, 0)$

Solving the second pair of equations

$$x + 2y = 1$$

$$6x + y = 17$$

we get $x = 3, y = -1$

So, another vertex of the triangle is $(3, -1)$

Solving the third pair of equations

$$5x - y = 5$$

$$6x + y = 17,$$

we get $x = 2, y = 5$.

So, the third vertex of the triangle is $(2, 5)$. So, the three vertices of the triangle are $(1, 0), (3, -1)$ and $(2, 5)$.

Sample Question 3 : Jamila sold a table and a chair for Rs 1050, thereby making a profit of 10% on the table and 25% on the chair. If she had taken a profit of 25% on the table and 10% on the chair she would have got Rs 1065. Find the cost price of each.

Solution : Let the cost price of the table be Rs x and the cost price of the chair be Rs y .

The selling price of the table, when it is sold at a profit of 10%

$$= \text{Rs } x + \frac{10}{100}x = \text{Rs } \frac{110}{100}x$$

The selling price of the chair when it is sold at a profit of 25%

$$= \text{Rs } y + \frac{25}{100}y = \text{Rs } \frac{125}{100}y$$

$$\text{So, } \frac{110}{100}x + \frac{125}{100}y = 10500 \quad (1)$$

When the table is sold at a profit of 25%, its selling price = Rs $\left(x + \frac{25}{100}x\right) = \text{Rs } \frac{125}{100}x$

When the chair is sold at a profit of 10%, its selling price = Rs $\left(y + \frac{10}{100}y\right) = \text{Rs } \frac{110}{100}y$

$$\text{So, } \frac{125}{100}x + \frac{110}{100}y = 10650 \quad (2)$$

From Equations (1) and (2), we get

$$110x + 125y = 105000$$

$$\text{and } 125x + 110y = 106500$$

On adding and subtracting these equations, we get

$$235x + 235y = 211500$$

$$\text{and } 15x - 15y = 1500$$

$$\text{i.e., } x + y = 900 \quad (3)$$

$$\text{and } x - y = 100 \quad (4)$$

Solving Equations (3) and (4), we get

$$x = 500, y = 400$$

So, the cost price of the table is Rs 500 and the cost price of the chair is Rs 400.

Sample Question 4: It can take 12 hours to fill a swimming pool using two pipes. If the pipe of larger diameter is used for 4 hours and the pipe of smaller diameter for 9 hours, only half the pool can be filled. How long would it take for each pipe to fill the pool separately?

Solution:

Let the time taken by the pipe of larger diameter to fill the pool be x hours and that taken by the pipe of smaller diameter pipe alone be y hours.

In x hours, the pipe of larger diameter fills the pool.

So, in 1 hour the pipe of larger diameter fills $\frac{1}{x}$ part of the pool, and so, in 4 hours, the pipe of larger diameter fills $\frac{4}{x}$ parts of the pool.

Similarly, in 9 hours, the pipe of smaller diameter fills $\frac{9}{y}$ parts of the pool.

According to the question,

$$\frac{4}{x} + \frac{9}{y} = \frac{1}{2} \quad (1)$$

Also, using both the pipes, the pool is filled in 12 hours.

$$\text{So, } \frac{12}{x} + \frac{12}{y} = 1 \quad (2)$$

Let $\frac{1}{x} = u$ and $\frac{1}{y} = v$. Then Equations (1) and (2) become

$$4u + 9v = \frac{1}{2} \quad (3)$$

$$12u + 12v = 1 \quad (4)$$

Multiplying Equation (3) by 3 and subtracting Equation (4) from it, we get

$$15v = \frac{1}{2} \text{ or } v = \frac{1}{30}$$

Substituting the value of v in Equation (4), we get $u = \frac{1}{20}$

$$\text{So, } u = \frac{1}{20}, v = \frac{1}{30}$$

$$\text{So, } \frac{1}{x} = \frac{1}{20}, \frac{1}{y} = \frac{1}{30}$$

$$\text{or, } x = 20, y = 30.$$

So, the pipe of larger diameter alone can fill the pool in 20 hours and the pipe of smaller diameter alone can fill the pool in 30 hours.

EXERCISE 3.4

- Graphically, solve the following pair of equations:

$$2x + y = 6$$

$$2x - y + 2 = 0$$

Find the ratio of the areas of the two triangles formed by the lines representing these equations with the x -axis and the lines with the y -axis.

- Determine, graphically, the vertices of the triangle formed by the lines

$$y = x, \quad 3y = x, \quad x + y = 8$$

- Draw the graphs of the equations $x = 3$, $x = 5$ and $2x - y - 4 = 0$. Also find the area of the quadrilateral formed by the lines and the x -axis.
- The cost of 4 pens and 4 pencil boxes is Rs 100. Three times the cost of a pen is Rs 15 more than the cost of a pencil box. Form the pair of linear equations for the above situation. Find the cost of a pen and a pencil box.
- Determine, algebraically, the vertices of the triangle formed by the lines

$$3x - y = 3$$

$$2x - 3y = 2$$

$$x + 2y = 8$$

- Ankita travels 14 km to her home partly by rickshaw and partly by bus. She takes half an hour if she travels 2 km by rickshaw, and the remaining distance by bus.

On the other hand, if she travels 4 km by rickshaw and the remaining distance by bus, she takes 9 minutes longer. Find the speed of the rickshaw and of the bus.

7. A person, rowing at the rate of 5 km/h in still water, takes thrice as much time in going 40 km upstream as in going 40 km downstream. Find the speed of the stream.
8. A motor boat can travel 30 km upstream and 28 km downstream in 7 hours. It can travel 21 km upstream and return in 5 hours. Find the speed of the boat in still water and the speed of the stream.
9. A two-digit number is obtained by either multiplying the sum of the digits by 8 and then subtracting 5 or by multiplying the difference of the digits by 16 and then adding 3. Find the number.
10. A railway half ticket costs half the full fare, but the reservation charges are the same on a half ticket as on a full ticket. One reserved first class ticket from the station A to B costs Rs 2530. Also, one reserved first class ticket and one reserved first class half ticket from A to B costs Rs 3810. Find the full first class fare from station A to B, and also the reservation charges for a ticket.
11. A shopkeeper sells a saree at 8% profit and a sweater at 10% discount, thereby, getting a sum Rs 1008. If she had sold the saree at 10% profit and the sweater at 8% discount, she would have got Rs 1028. Find the cost price of the saree and the list price (price before discount) of the sweater.
12. Susan invested certain amount of money in two schemes A and B, which offer interest at the rate of 8% per annum and 9% per annum, respectively. She received Rs 1860 as annual interest. However, had she interchanged the amount of investments in the two schemes, she would have received Rs 20 more as annual interest. How much money did she invest in each scheme?
13. Vijay had some bananas, and he divided them into two lots A and B. He sold the first lot at the rate of Rs 2 for 3 bananas and the second lot at the rate of Re 1 per banana, and got a total of Rs 400. If he had sold the first lot at the rate of Re 1 per banana, and the second lot at the rate of Rs 4 for 5 bananas, his total collection would have been Rs 460. Find the total number of bananas he had.

QUADRATIC EQUATIONS

(A) Main Concepts and Results

- Quadratic equation : A quadratic equation in the variable x is of the form $ax^2 + bx + c = 0$, where a, b, c are real numbers and $a \neq 0$.
- Roots of a quadratic equation : A real number α is said to be a root of the quadratic equation $ax^2 + bx + c = 0$, if $a\alpha^2 + b\alpha + c = 0$.
- The roots of the quadratic equation $ax^2 + bx + c = 0$ are the same as the zeroes of the quadratic polynomial $ax^2 + bx + c$.
- Finding the roots of a quadratic equation by the method of factorisation : If we can factorise the quadratic polynomial $ax^2 + bx + c$, then the roots of the quadratic equation $ax^2 + bx + c = 0$ can be found by equating to zero the linear factors of $ax^2 + bx + c$.
- Finding the roots of a quadratic equation by the method of completing the square : By adding and subtracting a suitable constant, we club the x^2 and x terms in the quadratic equation so that they become a complete square, and solve for x .
- Quadratic Formula : If $b^2 - 4ac \geq 0$, then the real roots of the quadratic equation $ax^2 + bx + c = 0$ are given by $\frac{-b}{2a} \pm \frac{\sqrt{b^2 - 4ac}}{2a}$.
- The expression $b^2 - 4ac$ is called the discriminant of the quadratic equation.
- Existence of roots of a quadratic equation: A quadratic equation $ax^2 + bx + c = 0$ has

- (i) two distinct real roots if $b^2 - 4ac > 0$
- (ii) two equal real roots if $b^2 - 4ac = 0$
- (iii) no real roots if $b^2 - 4ac < 0$.

(B) Multiple Choice Questions

Choose the correct answer from the given four options:

Sample Question 1 : Which one of the following is not a quadratic equation?

- (A) $(x + 2)^2 = 2(x + 3)$
- (B) $x^2 + 3x = (-1)(1 - 3x)^2$
- (C) $(x + 2)(x - 1) = x^2 - 2x - 3$
- (D) $x^3 - x^2 + 2x + 1 = (x + 1)^3$

Solution : Answer (C)

Sample Question 2 : Which constant should be added and subtracted to solve the quadratic equation $4x^2 - \sqrt{3}x - 5 = 0$ by the method of completing the square?

- (A) $\frac{9}{16}$
- (B) $\frac{3}{16}$
- (C) $\frac{3}{4}$
- (D) $\frac{\sqrt{3}}{4}$

Solution : Answer (B)

EXERCISE 4.1

Choose the correct answer from the given four options in the following questions:

1. Which of the following is a quadratic equation?

- (A) $x^2 + 2x + 1 = (4 - x)^2 + 3$
- (B) $-2x^2 = (5 - x) \left(2x - \frac{2}{5} \right)$
- (C) $(k + 1)x^2 + \frac{3}{2}x = 7$, where $k = -1$
- (D) $x^3 - x^2 = (x - 1)^3$

2. Which of the following is not a quadratic equation?

- (A) $2(x - 1)^2 = 4x^2 - 2x + 1$
- (B) $2x - x^2 = x^2 + 5$
- (C) $(\sqrt{2}x + \sqrt{3})^2 + x^2 = 3x^2 - 5x$
- (D) $(x^2 + 2x)^2 = x^4 + 3 + 4x^3$

3. Which of the following equations has 2 as a root?

- (A) $x^2 - 4x + 5 = 0$
- (B) $x^2 + 3x - 12 = 0$
- (C) $2x^2 - 7x + 6 = 0$
- (D) $3x^2 - 6x - 2 = 0$

4. If $\frac{1}{2}$ is a root of the equation $x^2 + kx - \frac{5}{4} = 0$, then the value of k is
- (A) 2 (B) -2 (C) $\frac{1}{4}$ (D) $\frac{1}{2}$
5. Which of the following equations has the sum of its roots as 3?
- (A) $2x^2 - 3x + 6 = 0$ (B) $-x^2 + 3x - 3 = 0$
- (C) $\sqrt{2}x^2 - \frac{3}{\sqrt{2}}x + 1 = 0$ (D) $3x^2 - 3x + 3 = 0$
6. Values of k for which the quadratic equation $2x^2 - kx + k = 0$ has equal roots is
- (A) 0 only (B) 4 (C) 8 only (D) 0, 8
7. Which constant must be added and subtracted to solve the quadratic equation $9x^2 + \frac{3}{4}x - \sqrt{2} = 0$ by the method of completing the square?
- (A) $\frac{1}{8}$ (B) $\frac{1}{64}$ (C) $\frac{1}{4}$ (D) $\frac{9}{64}$
8. The quadratic equation $2x^2 - \sqrt{5}x + 1 = 0$ has
- (A) two distinct real roots (B) two equal real roots
- (C) no real roots (D) more than 2 real roots
9. Which of the following equations has two distinct real roots?
- (A) $2x^2 - 3\sqrt{2}x + \frac{9}{4} = 0$ (B) $x^2 + x - 5 = 0$
- (C) $x^2 + 3x + 2\sqrt{2} = 0$ (D) $5x^2 - 3x + 1 = 0$
10. Which of the following equations has no real roots?
- (A) $x^2 - 4x + 3\sqrt{2} = 0$ (B) $x^2 + 4x - 3\sqrt{2} = 0$
- (C) $x^2 - 4x - 3\sqrt{2} = 0$ (D) $3x^2 + 4\sqrt{3}x + 4 = 0$

11. $(x^2 + 1)^2 - x^2 = 0$ has

- (A) four real roots (B) two real roots
 (C) no real roots (D) one real root.

(C) Short Answer Questions with Reasoning

Sample Question 1 : Does $(x - 1)^2 + 2(x + 1) = 0$ have a real root? Justify your answer.

Solution : No, since the equation is simplified to $x^2 + 3 = 0$ whose discriminant is -12 .

Sample Question 2 : Is the following statement 'True' or 'False'? Justify your answer. If in a quadratic equation the coefficient of x is zero, then the quadratic equation has no real roots.

Solution : False, since the discriminant in this case is $-4ac$ which can still be non-negative if a and c are of opposite signs or if one of a or c is zero.

EXERCISE 4.2

1. State whether the following quadratic equations have two distinct real roots. Justify your answer.

(i) $x^2 - 3x + 4 = 0$

(ii) $2x^2 + x - 1 = 0$

(iii) $2x^2 - 6x + \frac{9}{2} = 0$

(iv) $3x^2 - 4x + 1 = 0$

(v) $(x + 4)^2 - 8x = 0$

(vi) $(x - \sqrt{2})^2 - 2(x + 1) = 0$

(vii) $\sqrt{2}x^2 - \frac{3}{\sqrt{2}}x + \frac{1}{\sqrt{2}} = 0$

(viii) $x(1 - x) - 2 = 0$

(ix) $(x - 1)(x + 2) + 2 = 0$

(x) $(x + 1)(x - 2) + x = 0$

2. Write whether the following statements are true or false. Justify your answers.

- (i) Every quadratic equation has exactly one root.
 (ii) Every quadratic equation has at least one real root.
 (iii) Every quadratic equation has at least two roots.
 (iv) Every quadratic equations has at most two roots.
 (v) If the coefficient of x^2 and the constant term of a quadratic equation have opposite signs, then the quadratic equation has real roots.

- (vi) If the coefficient of x^2 and the constant term have the same sign and if the coefficient of x term is zero, then the quadratic equation has no real roots.
3. A quadratic equation with integral coefficient has integral roots. Justify your answer.
 4. Does there exist a quadratic equation whose coefficients are rational but both of its roots are irrational? Justify your answer.
 5. Does there exist a quadratic equation whose coefficients are all distinct irrationals but both the roots are rationals? Why?
 6. Is 0.2 a root of the equation $x^2 - 0.4 = 0$? Justify.
 7. If $b = 0, c < 0$, is it true that the roots of $x^2 + bx + c = 0$ are numerically equal and opposite in sign? Justify.

(D) Short Answer Questions

Sample Question 1 : Find the roots of the quadratic equation $2x^2 - \sqrt{5}x - 2 = 0$ using the quadratic formula.

Solution : $b^2 - 4ac = 5 - 4 \times 2 \times (-2) = 21$

Therefore, the roots are $\frac{\sqrt{5} \pm \sqrt{21}}{4}$, i.e., $\frac{\sqrt{5} + \sqrt{21}}{4}$ and $\frac{\sqrt{5} - \sqrt{21}}{4}$

Sample Question 2 : Find the roots of $6x^2 - \sqrt{2}x - 2 = 0$ by the factorisation of the corresponding quadratic polynomial.

Solution :

$$\begin{aligned}
 6x^2 - \sqrt{2}x - 2 &= 6x^2 - 3\sqrt{2}x + 2\sqrt{2}x - 2 \\
 &= 3x(2x - \sqrt{2}) + \sqrt{2}(2x - \sqrt{2}) \\
 &= (3x + \sqrt{2})(2x - \sqrt{2})
 \end{aligned}$$

Now, $6x^2 - \sqrt{2}x - 2 = 0$ gives $(3x + \sqrt{2})(2x - \sqrt{2}) = 0$, i.e., $3x + \sqrt{2} = 0$ or $2x - \sqrt{2} = 0$

So, the roots are $-\frac{\sqrt{2}}{3}$ and $\frac{\sqrt{2}}{2}$.

EXERCISE 4.3

1. Find the roots of the quadratic equations by using the quadratic formula in each of the following:

(i) $2x^2 - 3x - 5 = 0$

(ii) $5x^2 + 13x + 8 = 0$

(iii) $-3x^2 + 5x + 12 = 0$

(iv) $-x^2 + 7x - 10 = 0$

(v) $x^2 + 2\sqrt{2}x - 6 = 0$

(vi) $x^2 - 3\sqrt{5}x + 10 = 0$

(vii) $\frac{1}{2}x^2 - \sqrt{11}x + 1 = 0$

2. Find the roots of the following quadratic equations by the factorisation method:

(i) $2x^2 + \frac{5}{3}x - 2 = 0$

(ii) $\frac{2}{5}x^2 - x - \frac{3}{5} = 0$

(iii) $3\sqrt{2}x^2 - 5x - \sqrt{2} = 0$

(iv) $3x^2 + 5\sqrt{5}x - 10 = 0$

(v) $21x^2 - 2x + \frac{1}{21} = 0$

(E) Long Answer Questions

Sample Question 1 : Check whether the equation $6x^2 - 7x + 2 = 0$ has real roots, and if it has, find them by the method of completing the squares.

Solution : The discriminant $= b^2 - 4ac = 49 - 4 \times 6 \times 2 = 1 > 0$

So, the given equation has two distinct real roots.

Now, $6x^2 - 7x + 2 = 0$

i.e., $36x^2 - 42x + 12 = 0$

i.e., $6x - \frac{7}{2} + 12 - \frac{49}{4} = 0$

i.e., $6x - \frac{7}{2} - \frac{1}{2} = 0$ or $\left(6x - \frac{7}{2}\right)^2 = \left(\frac{1}{2}\right)^2$

The roots are given by $6x - \frac{7}{2} = \pm \frac{1}{2}$

i.e., $6x = 4, 3$

i.e., $x = \frac{2}{3}, \frac{1}{2}$.

Sample Question 2 : Had Ajita scored 10 more marks in her mathematics test out of 30 marks, 9 times these marks would have been the square of her actual marks. How many marks did she get in the test?

Solution : Let her actual marks be x

Therefore, $9(x+10) = x^2$

i.e., $x^2 - 9x - 90 = 0$

i.e., $x^2 - 15x + 6x - 90 = 0$

i.e., $x(x-15) + 6(x-15) = 0$

i.e., $(x+6)(x-15) = 0$

Therefore, $x = -6$ or $x = 15$

Since x is the marks obtained, $x \neq -6$. Therefore, $x = 15$.

So, Ajita got 15 marks in her mathematics test.

Sample Question 3 : A train travels at a certain average speed for a distance of 63 km and then travels a distance of 72 km at an average speed of 6 km/h more than its original speed. If it takes 3 hours to complete the total journey, what is its original average speed?

Solution : Let its original average speed be x km/h. Therefore,

$$\frac{63}{x} + \frac{72}{x+6} = 3$$

i.e., $\frac{7}{x} + \frac{8}{x+6} = \frac{3}{9} = \frac{1}{3}$

i.e., $\frac{7(x+6)+8x}{x(x+6)} = \frac{1}{3}$

$$\text{i.e.,} \quad 21(x + 6) + 24x = x(x + 6)$$

$$\text{i.e.,} \quad 21x + 126 + 24x = x^2 + 6x$$

$$\text{i.e.,} \quad x^2 - 39x - 126 = 0$$

$$\text{i.e.,} \quad (x + 3)(x - 42) = 0$$

$$\text{i.e.,} \quad x = -3 \text{ or } x = 42$$

Since x is the average speed of the train, x cannot be negative.

Therefore, $x = 42$.

So, the original average speed of the train is 42 km/h.

EXERCISE 4.4

1. Find whether the following equations have real roots. If real roots exist, find them.

(i) $8x^2 + 2x - 3 = 0$

(ii) $-2x^2 + 3x + 2 = 0$

(iii) $5x^2 - 2x - 10 = 0$

(iv) $\frac{1}{2x-3} + \frac{1}{x-5} = 1, x \neq \frac{3}{2}, 5$

(v) $x^2 + 5\sqrt{5}x - 70 = 0$

2. Find a natural number whose square diminished by 84 is equal to thrice of 8 more than the given number.
3. A natural number, when increased by 12, equals 160 times its reciprocal. Find the number.
4. A train, travelling at a uniform speed for 360 km, would have taken 48 minutes less to travel the same distance if its speed were 5 km/h more. Find the original speed of the train.
5. If Zeba were younger by 5 years than what she really is, then the square of her age (in years) would have been 11 more than five times her actual age. What is her age now?
6. At present Asha's age (in years) is 2 more than the square of her daughter Nisha's age. When Nisha grows to her mother's present age, Asha's age would be one year less than 10 times the present age of Nisha. Find the present ages of both Asha and Nisha.

7. In the centre of a rectangular lawn of dimensions $50\text{ m} \times 40\text{ m}$, a rectangular pond has to be constructed so that the area of the grass surrounding the pond would be 1184 m^2 [see Fig. 4.1]. Find the length and breadth of the pond.

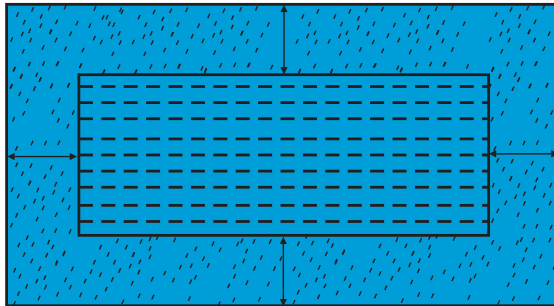

Fig. 4.1

8. At t minutes past 2 pm, the time needed by the minutes hand of a clock to show 3 pm was found to be 3 minutes less than $\frac{t^2}{4}$ minutes. Find t .

ARITHMETIC PROGRESSIONS

(A) Main Concepts and Results

- An arithmetic progression (AP) is a list of numbers in which each term is obtained by adding a fixed number d to the preceding term, except the first term a . The fixed number d is called its common difference.

The general form of an AP is $a, a + d, a + 2d, a + 3d, \dots$

- In the list of numbers a_1, a_2, a_3, \dots if the differences $a_2 - a_1, a_3 - a_2, a_4 - a_3, \dots$ give the same value, i.e., if $a_{k+1} - a_k$ is the same for different values of k , then the given list of numbers is an AP.
- The n^{th} term a_n (or the general term) of an AP is $a_n = a + (n - 1) d$, where a is the first term and d is the common difference. Note that $a_1 = a$.
- The sum S_n of the first n terms of an AP is given by

$$S_n = \frac{n}{2} [2a + (n - 1) d]$$

If l is the last term of an AP of n terms, then the sum of all the terms can also be given by

$$S_n = \frac{n}{2} [a + l]$$

Sometimes S_n is also denoted by S .

- If S_n is the sum of the first n terms of an AP, then its n^{th} term a_n is given by

$$a_n = S_n - S_{n-1}$$

(B) Multiple Choice Questions

Choose the correct answer from the given four options:

Sample Question 1 : The 10th term of the AP: 5, 8, 11, 14, ... is

- (A) 32 (B) 35 (C) 38 (D) 185

Solution : Answer (A)

Sample Question 2 : In an AP if $a = -7.2$, $d = 3.6$, $a_n = 7.2$, then n is

- (A) 1 (B) 3 (C) 4 (D) 5

Solution : Answer (D)

EXERCISE 5.1

Choose the correct answer from the given four options:

- In an AP, if $d = -4$, $n = 7$, $a_n = 4$, then a is
 (A) 6 (B) 7 (C) 20 (D) 28
- In an AP, if $a = 3.5$, $d = 0$, $n = 101$, then a_n will be
 (A) 0 (B) 3.5 (C) 103.5 (D) 104.5
- The list of numbers $-10, -6, -2, 2, \dots$ is
 (A) an AP with $d = -16$
 (B) an AP with $d = 4$
 (C) an AP with $d = -4$
 (D) not an AP
- The 11th term of the AP: $-5, \frac{-5}{2}, 0, \frac{5}{2}, \dots$ is
 (A) -20 (B) 20 (C) -30 (D) 30
- The first four terms of an AP, whose first term is -2 and the common difference is -2 , are

- (A) $-2, 0, 2, 4$
(B) $-2, 4, -8, 16$
(C) $-2, -4, -6, -8$
(D) $-2, -4, -8, -16$
6. The 21st term of the AP whose first two terms are -3 and 4 is
(A) 17 (B) 137 (C) 143 (D) -143
7. If the 2nd term of an AP is 13 and the 5th term is 25, what is its 7th term?
(A) 30 (B) 33 (C) 37 (D) 38
8. Which term of the AP: 21, 42, 63, 84,... is 210?
(A) 9th (B) 10th (C) 11th (D) 12th
9. If the common difference of an AP is 5, then what is $a_{18} - a_{13}$?
(A) 5 (B) 20 (C) 25 (D) 30
10. What is the common difference of an AP in which $a_{18} - a_{14} = 32$?
(A) 8 (B) -8 (C) -4 (D) 4
11. Two APs have the same common difference. The first term of one of these is -1 and that of the other is -8 . Then the difference between their 4th terms is
(A) -1 (B) -8 (C) 7 (D) -9
12. If 7 times the 7th term of an AP is equal to 11 times its 11th term, then its 18th term will be
(A) 7 (B) 11 (C) 18 (D) 0
13. The 4th term from the end of the AP: $-11, -8, -5, \dots, 49$ is
(A) 37 (B) 40 (C) 43 (D) 58
14. The famous mathematician associated with finding the sum of the first 100 natural numbers is
(A) Pythagoras (B) Newton
(C) Gauss (D) Euclid
15. If the first term of an AP is -5 and the common difference is 2, then the sum of the first 6 terms is
(A) 0 (B) 5 (C) 6 (D) 15

- 16.** The sum of first 16 terms of the AP: 10, 6, 2,... is
 (A) -320 (B) 320 (C) -352 (D) -400
- 17.** In an AP if $a = 1$, $a_n = 20$ and $S_n = 399$, then n is
 (A) 19 (B) 21 (C) 38 (D) 42
- 18.** The sum of first five multiples of 3 is
 (A) 45 (B) 55 (C) 65 (D) 75

(C) Short Answer Questions with Reasoning

Sample Question 1: In the AP: 10, 5, 0, -5, ... the common difference d is equal to 5.

Justify whether the above statement is true or false.

Solution :

$$a_2 - a_1 = 5 - 10 = -5$$

$$a_3 - a_2 = 0 - 5 = -5$$

$$a_4 - a_3 = -5 - 0 = -5$$

Although the given list of numbers forms an AP, it is with $d = -5$ and not with $d = 5$

So, the given statement is false.

Sample Question 2 : Divya deposited Rs 1000 at compound interest at the rate of 10% per annum. The amounts at the end of first year, second year, third year, ..., form an AP. Justify your answer.

Solution : Amount at the end of the 1st year = Rs 1100

Amount at the end of the 2nd year = Rs 1210

Amount at the end of 3rd year = Rs 1331 and so on.

So, the amount (in Rs) at the end of 1st year, 2nd year, 3rd year, ... are

1100, 1210, 1331, ...

Here, $a_2 - a_1 = 110$

$a_3 - a_2 = 121$

As, $a_2 - a_1 \neq a_3 - a_2$, it does not form an AP.

Sample Question 3: The n^{th} term of an AP cannot be $n^2 + 1$. Justify your answer.

Solution :

Here, $a_n = n^2 + 1$

So, $a_1 = 1^2 + 1 = 2$

$a_2 = 2^2 + 1 = 5$

$a_3 = 3^2 + 1 = 10$

\vdots

List of numbers becomes 2, 5, 10, ...

Here, $5 - 2 \neq 10 - 5$, so it does not form an AP.

Alternative Solution 1:

We know that in an AP, $d = a_n - a_{n-1}$

Here, $a_n = n^2 + 1$

So, $a_n - a_{n-1} = (n^2 + 1) - (n-1)^2 + 1$
 $= 2n - 1$

As $a_n - a_{n-1}$ depends upon n , d is not a fixed number.

So, $a_n = n^2 + 1$ cannot be the n^{th} term of an AP.

Alternative Solution 2:

We know that in an AP

$a_n = a + (n-1)d$. We observe that a_n is a linear polynomial in n .

Here, $a_n = n^2 + 1$ is not a linear polynomial in n . So, it cannot be the n^{th} term of an AP.

EXERCISE 5.2

1. Which of the following form an AP? Justify your answer.

(i) $-1, -1, -1, -1, \dots$

(ii) $0, 2, 0, 2, \dots$

(iii) $1, 1, 2, 2, 3, 3, \dots$

(iv) $11, 22, 33, \dots$

(v) $\frac{1}{2}, \frac{1}{3}, \frac{1}{4}, \dots$

(vi) $2, 2^2, 2^3, 2^4, \dots$

(vii) $\sqrt{3}, \sqrt{12}, \sqrt{27}, \sqrt{48}, \dots$

2. Justify whether it is true to say that $-1, -\frac{3}{2}, -2, \frac{5}{2}, \dots$ forms an AP as

$$a_2 - a_1 = a_3 - a_2.$$

3. For the AP: $-3, -7, -11, \dots$, can we find directly $a_{30} - a_{20}$ without actually finding a_{30} and a_{20} ? Give reasons for your answer.

4. Two APs have the same common difference. The first term of one AP is 2 and that of the other is 7. The difference between their 10th terms is the same as the difference between their 21st terms, which is the same as the difference between any two corresponding terms. Why?

5. Is 0 a term of the AP: $31, 28, 25, \dots$? Justify your answer.

6. The taxi fare after each km, when the fare is Rs 15 for the first km and Rs 8 for each additional km, does not form an AP as the total fare (in Rs) after each km is

$$15, 8, 8, 8, \dots$$

Is the statement true? Give reasons.

7. In which of the following situations, do the lists of numbers involved form an AP? Give reasons for your answers.

(i) The fee charged from a student every month by a school for the whole session, when the monthly fee is Rs 400.

- (ii) The fee charged every month by a school from Classes I to XII, when the monthly fee for Class I is Rs 250, and it increases by Rs 50 for the next higher class.
- (iii) The amount of money in the account of Varun at the end of every year when Rs 1000 is deposited at simple interest of 10% per annum.
- (iv) The number of bacteria in a certain food item after each second, when they double in every second.
8. Justify whether it is true to say that the following are the n^{th} terms of an AP.
- (i) $2n-3$ (ii) $3n^2+5$ (iii) $1+n+n^2$

(D) Short Answer Questions

Sample Question 1 : If the numbers $n - 2$, $4n - 1$ and $5n + 2$ are in AP, find the value of n .

Solution :

As $n - 2$, $4n - 1$, $5n + 2$ are in AP,

$$\text{so } (4n - 1) - (n - 2) = (5n + 2) - (4n - 1)$$

$$\text{i.e., } 3n + 1 = n + 3$$

$$\text{i.e., } n = 1$$

Sample Question 2 : Find the value of the middle most term (s) of the AP : $-11, -7, -3, \dots, 49$.

Solution :

$$\text{Here, } a = -11, \quad d = -7 - (-11) = 4, \quad a_n = 49$$

$$\text{We have } a_n = a + (n - 1) d$$

$$\text{So, } 49 = -11 + (n - 1) \times 4$$

$$\text{i.e., } 60 = (n - 1) \times 4$$

$$\text{i.e., } n = 16$$

As n is an even number, there will be two middle terms which are

$\frac{16}{2}$ th and $\left(\frac{16}{2} + 1\right)$ th, i.e., the 8th term and the 9th term.

$$a_8 = a + 7d = -11 + 7 \times 4 = 17$$

$$a_9 = a + 8d = -11 + 8 \times 4 = 21$$

So, the values of the two middle most terms are 17 and 21, respectively.

Sample Question 3: The sum of the first three terms of an AP is 33. If the product of the first and the third term exceeds the second term by 29, find the AP.

Solution : Let the three terms in AP be

$$a - d, a, a + d.$$

So, $a - d + a + a + d = 33$

or $a = 11$

Also, $(a - d)(a + d) = a + 29$

i.e., $a^2 - d^2 = a + 29$

i.e., $121 - d^2 = 11 + 29$

i.e., $d^2 = 81$

i.e., $d = \pm 9$

So there will be two APs and they are : 2, 11, 20, ...

and 20, 11, 2, ...

EXERCISE 5.3

1. Match the APs given in column A with suitable common differences given in column B.

Column A

(A₁) 2, -2, -6, -10, ...

(A₂) $a = -18, n = 10, a_n = 0$

(A₃) $a = 0, a_{10} = 6$

(A₄) $a_2 = 13, a_4 = 3$

Column B

(B₁) $\frac{2}{3}$

(B₂) -5

(B₃) 4

(B₄) -4

(B₅) 2

(B₆) $\frac{1}{2}$

(B₇) 5

2. Verify that each of the following is an AP, and then write its next three terms.

(i) $0, \frac{1}{4}, \frac{1}{2}, \frac{3}{4}, \dots$

(ii) $5, \frac{14}{3}, \frac{13}{3}, 4, \dots$

(iii) $\sqrt{3}, 2\sqrt{3}, 3\sqrt{3}, \dots$

(iv) $a + b, (a + 1) + b, (a + 1) + (b + 1), \dots$

(v) $a, 2a + 1, 3a + 2, 4a + 3, \dots$

3. Write the first three terms of the APs when a and d are as given below:

(i) $a = \frac{1}{2}, d = -\frac{1}{6}$

(ii) $a = -5, d = -3$

(iii) $a = \sqrt{2}, d = \frac{1}{\sqrt{2}}$

4. Find a, b and c such that the following numbers are in AP: $a, 7, b, 23, c$.

5. Determine the AP whose fifth term is 19 and the difference of the eighth term from the thirteenth term is 20.

6. The 26th, 11th and the last term of an AP are 0, 3 and $-\frac{1}{5}$, respectively. Find the common difference and the number of terms.

7. The sum of the 5th and the 7th terms of an AP is 52 and the 10th term is 46. Find the AP.

8. Find the 20th term of the AP whose 7th term is 24 less than the 11th term, first term being 12.

9. If the 9th term of an AP is zero, prove that its 29th term is twice its 19th term.

10. Find whether 55 is a term of the AP: 7, 10, 13, --- or not. If yes, find which term it is.

11. Determine k so that $k^2 + 4k + 8$, $2k^2 + 3k + 6$, $3k^2 + 4k + 4$ are three consecutive terms of an AP.
12. Split 207 into three parts such that these are in AP and the product of the two smaller parts is 4623.
13. The angles of a triangle are in AP. The greatest angle is twice the least. Find all the angles of the triangle.
14. If the n th terms of the two APs: 9, 7, 5, ... and 24, 21, 18, ... are the same, find the value of n . Also find that term.
15. If sum of the 3rd and the 8th terms of an AP is 7 and the sum of the 7th and the 14th terms is -3 , find the 10th term.
16. Find the 12th term from the end of the AP: $-2, -4, -6, \dots, -100$.
17. Which term of the AP: 53, 48, 43, ... is the first negative term?
18. How many numbers lie between 10 and 300, which when divided by 4 leave a remainder 3?
19. Find the sum of the two middle most terms of the AP: $-\frac{4}{3}, -1, -\frac{2}{3}, \dots, 4\frac{1}{3}$.
20. The first term of an AP is -5 and the last term is 45. If the sum of the terms of the AP is 120, then find the number of terms and the common difference.
21. Find the sum:
- (i) $1 + (-2) + (-5) + (-8) + \dots + (-236)$
- (ii) $4 - \frac{1}{n} + 4 - \frac{2}{n} + 4 - \frac{3}{n} + \dots$ upto n terms
- (iii) $\frac{a-b}{a+b} + \frac{3a-2b}{a+b} + \frac{5a-3b}{a+b} + \dots$ to 11 terms.
22. Which term of the AP: $-2, -7, -12, \dots$ will be -77 ? Find the sum of this AP upto the term -77 .
23. If $a_n = 3 - 4n$, show that a_1, a_2, a_3, \dots form an AP. Also find S_{20} .
24. In an AP, if $S_n = n(4n + 1)$, find the AP.

25. In an AP, if $S_n = 3n^2 + 5n$ and $a_k = 164$, find the value of k .
26. If S_n denotes the sum of first n terms of an AP, prove that
- $$S_{12} = 3(S_8 - S_4)$$
27. Find the sum of first 17 terms of an AP whose 4th and 9th terms are -15 and -30 respectively.
28. If sum of first 6 terms of an AP is 36 and that of the first 16 terms is 256, find the sum of first 10 terms.
29. Find the sum of all the 11 terms of an AP whose middle most term is 30.
30. Find the sum of last ten terms of the AP: 8, 10, 12, ---, 126.
31. Find the sum of first seven numbers which are multiples of 2 as well as of 9.
[Hint: Take the LCM of 2 and 9]
32. How many terms of the AP: $-15, -13, -11, \dots$ are needed to make the sum -55 ? Explain the reason for double answer.
33. The sum of the first n terms of an AP whose first term is 8 and the common difference is 20 is equal to the sum of first $2n$ terms of another AP whose first term is -30 and the common difference is 8. Find n .
34. Kanika was given her pocket money on Jan 1st, 2008. She puts Re 1 on Day 1, Rs 2 on Day 2, Rs 3 on Day 3, and continued doing so till the end of the month, from this money into her piggy bank. She also spent Rs 204 of her pocket money, and found that at the end of the month she still had Rs 100 with her. How much was her pocket money for the month?
35. Yasmeen saves Rs 32 during the first month, Rs 36 in the second month and Rs 40 in the third month. If she continues to save in this manner, in how many months will she save Rs 2000?

(E) Long Answer Questions

Sample Question 1: The sum of four consecutive numbers in an AP is 32 and the ratio of the product of the first and the last terms to the product of the two middle terms is 7 : 15. Find the numbers.

Solution: Let the four consecutive numbers in AP be

$$a - 3d, a - d, a + d, a + 3d.$$

$$\text{So, } a - 3d + a - d + a + d + a + 3d = 32$$

$$\text{or } 4a = 32$$

$$\text{or } a = 8$$

$$\text{Also, } \frac{(a-3d)(a+3d)}{(a-d)(a+d)} = \frac{7}{15}$$

$$\text{or, } \frac{a^2 - 9d^2}{a^2 - d^2} = \frac{7}{15}$$

$$\text{or, } 15a^2 - 135d^2 = 7a^2 - 7d^2$$

$$\text{or, } 8a^2 - 128d^2 = 0$$

$$\text{or, } d^2 = \frac{8 \times 8 \times 8}{128} = 4$$

$$\text{or, } d = \pm 2$$

So, when $a = 8$, $d = 2$, the numbers are 2, 6, 10, 14.

Sample Question 2: Solve the equation :

$$1 + 4 + 7 + 10 + \dots + x = 287$$

Solution :

Here, 1, 4, 7, 10, ..., x form an AP with $a = 1$, $d = 3$, $a_n = x$

We have, $a_n = a + (n - 1)d$

$$\text{So, } x = 1 + (n - 1) \times 3 = 3n - 2$$

$$\text{Also, } S = \frac{n}{2}(a + l)$$

$$\text{So, } 287 = \frac{n}{2}(1 + x)$$

$$= \frac{n}{2}(1+3n-2)$$

$$\text{or, } 574 = n(3n-1)$$

$$\text{or, } 3n^2 - n - 574 = 0$$

$$\text{Therefore, } n = \frac{1 \pm \sqrt{1+6888}}{6}$$

$$= \frac{1 \pm 83}{6} = \frac{84}{6}, \frac{-82}{6}$$

$$= 14, \frac{-41}{3}$$

As n cannot be negative, so $n = 14$

Therefore, $x = 3n - 2 = 3 \times 14 - 2 = 40$.

Alternative solution:

Here, 1, 4, 7, 10, ... x form an AP with $a = 1$, $d = 3$, $S = 287$

$$\text{We have, } S = \frac{n}{2} [2a + (n-1)d]$$

$$\text{So, } 287 = \frac{n}{2} [2 + (n-1) \times 3]$$

$$\text{or, } 574 = n(3n-1)$$

$$\text{or, } 3n^2 - n - 574 = 0$$

Now proceed as above.

EXERCISE 5.4

1. The sum of the first five terms of an AP and the sum of the first seven terms of the same AP is 167. If the sum of the first ten terms of this AP is 235, find the sum of its first twenty terms.

2. Find the

- (i) sum of those integers between 1 and 500 which are multiples of 2 as well as of 5.
- (ii) sum of those integers from 1 to 500 which are multiples of 2 as well as of 5 .
- (iii) sum of those integers from 1 to 500 which are multiples of 2 or 5.

[Hint (iii) : These numbers will be : multiples of 2 + multiples of 5 – multiples of 2 as well as of 5]

- 3. The eighth term of an AP is half its second term and the eleventh term exceeds one third of its fourth term by 1. Find the 15th term.
- 4. An AP consists of 37 terms. The sum of the three middle most terms is 225 and the sum of the last three is 429. Find the AP.

5. Find the sum of the integers between 100 and 200 that are

- (i) divisible by 9
- (ii) not divisible by 9

[Hint (ii) : These numbers will be : Total numbers – Total numbers divisible by 9]

- 6. The ratio of the 11th term to the 18th term of an AP is 2 : 3. Find the ratio of the 5th term to the 21st term, and also the ratio of the sum of the first five terms to the sum of the first 21 terms.
- 7. Show that the sum of an AP whose first term is a , the second term b and the last term c , is equal to

$$\frac{(a+c)(b+c-2a)}{2(b-a)}$$

8. Solve the equation

$$-4 + (-1) + 2 + \dots + x = 437$$

- 9. Jaspal Singh repays his total loan of Rs 118000 by paying every month starting with the first instalment of Rs 1000. If he increases the instalment by Rs 100 every month, what amount will be paid by him in the 30th instalment? What amount of loan does he still have to pay after the 30th instalment?

- 10.** The students of a school decided to beautify the school on the Annual Day by fixing colourful flags on the straight passage of the school. They have 27 flags to be fixed at intervals of every 2 m. The flags are stored at the position of the middle most flag. Ruchi was given the responsibility of placing the flags. Ruchi kept her books where the flags were stored. She could carry only one flag at a time. How much distance did she cover in completing this job and returning back to collect her books? What is the maximum distance she travelled carrying a flag?

TRIANGLES

(A) Main Concepts and Results

Congruence and similarity, Conditions for similarity of two polygons, Similarity of Triangles, Similarity and correspondence of vertices, Criteria for similarity of triangles; (i) AAA or AA (ii) SSS (iii) SAS

- If a line is drawn parallel to one side of a triangle to intersect the other two sides, then these two sides are divided in the same ratio (Basic Proportionality Theorem) and its converse.
- Ratio of the areas of two similar triangles is equal to the ratio of the squares of their corresponding sides.
- Perpendicular drawn from the vertex of the right angle of a right triangle to its hypotenuse divides the triangle into two triangles which are similar to the whole triangle and to each other.
- In a right triangle, the square on the hypotenuse is equal to the sum of the squares on the other two sides (Pythagoras Theorem) and its converse.

(B) Multiple Choice Questions

Choose the correct answer from the given four options:

Sample Question 1: If in Fig 6.1, O is the point of intersection of two chords AB and CD such that $OB = OD$, then triangles OAC and ODB are

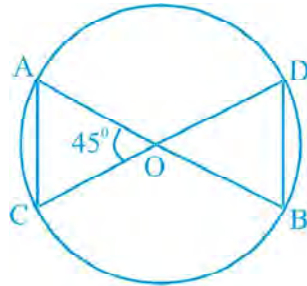

Fig. 6.1

- (A) equilateral but not similar
- (B) isosceles but not similar
- (C) equilateral and similar
- (D) isosceles and similar

Solution : Answer (D)

Sample Question 2: D and E are respectively the points on the sides AB and AC of a triangle ABC such that $AD = 2$ cm, $BD = 3$ cm, $BC = 7.5$ cm and $DE \parallel BC$. Then, length of DE (in cm) is

- (A) 2.5
- (B) 3
- (C) 5
- (D) 6

Solution : Answer (B)

EXERCISE 6.1

Choose the correct answer from the given four options:

1. In Fig. 6.2, $\angle BAC = 90^\circ$ and $AD \perp BC$. Then,

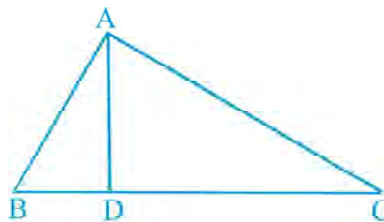

Fig. 6.2

- (A) $BD \cdot CD = BC^2$ (B) $AB \cdot AC = BC^2$
 (C) $BD \cdot CD = AD^2$ (D) $AB \cdot AC = AD^2$
2. The lengths of the diagonals of a rhombus are 16 cm and 12 cm. Then, the length of the side of the rhombus is
 (A) 9 cm (B) 10 cm (C) 8 cm (D) 20 cm
3. If $\triangle ABC \sim \triangle EDF$ and $\triangle ABC$ is not similar to $\triangle DEF$, then which of the following is not true?
 (A) $BC \cdot EF = AC \cdot FD$ (B) $AB \cdot EF = AC \cdot DE$
 (C) $BC \cdot DE = AB \cdot EF$ (D) $BC \cdot DE = AB \cdot FD$
4. If in two triangles ABC and PQR, $\frac{AB}{QR} = \frac{BC}{PR} = \frac{CA}{PQ}$, then
 (A) $\triangle PQR \sim \triangle CAB$ (B) $\triangle PQR \sim \triangle ABC$
 (C) $\triangle CBA \sim \triangle PQR$ (D) $\triangle BCA \sim \triangle PQR$
5. In Fig.6.3, two line segments AC and BD intersect each other at the point P such that $PA = 6$ cm, $PB = 3$ cm, $PC = 2.5$ cm, $PD = 5$ cm, $\angle APB = 50^\circ$ and $\angle CDP = 30^\circ$. Then, $\angle PBA$ is equal to

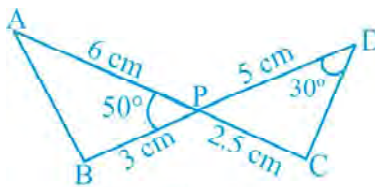

Fig. 6.3

- (A) 50° (B) 30° (C) 60° (D) 100°
6. If in two triangles DEF and PQR, $\angle D = \angle Q$ and $\angle R = \angle E$, then which of the following is not true?
 (A) $\frac{EF}{PR} = \frac{DF}{PQ}$ (B) $\frac{DE}{PQ} = \frac{EF}{RP}$

$$(C) \frac{DE}{QR} = \frac{DF}{PQ} \qquad (D) \frac{EF}{RP} = \frac{DE}{QR}$$

7. In triangles ABC and DEF, $\angle B = \angle E$, $\angle F = \angle C$ and $AB = 3 DE$. Then, the two triangles are
- (A) congruent but not similar (B) similar but not congruent
 (C) neither congruent nor similar (D) congruent as well as similar
8. It is given that $\Delta ABC \sim \Delta PQR$, with $\frac{BC}{QR} = \frac{1}{3}$. Then, $\frac{\text{ar}(\text{PRQ})}{\text{ar}(\text{BCA})}$ is equal to
- (A) 9 (B) 3 (C) $\frac{1}{3}$ (D) $\frac{1}{9}$
9. It is given that $\Delta ABC \sim \Delta DFE$, $\angle A = 30^\circ$, $\angle C = 50^\circ$, $AB = 5$ cm, $AC = 8$ cm and $DF = 7.5$ cm. Then, the following is true:
- (A) $DE = 12$ cm, $\angle F = 50^\circ$ (B) $DE = 12$ cm, $\angle F = 100^\circ$
 (C) $EF = 12$ cm, $\angle D = 100^\circ$ (D) $EF = 12$ cm, $\angle D = 30^\circ$
10. If in triangles ABC and DEF, $\frac{AB}{DE} = \frac{BC}{FD}$, then they will be similar, when
- (A) $\angle B = \angle E$ (B) $\angle A = \angle D$
 (C) $\angle B = \angle D$ (D) $\angle A = \angle F$
11. If $\Delta ABC \sim \Delta QRP$, $\frac{\text{ar}(\text{ABC})}{\text{ar}(\text{PQR})} = \frac{9}{4}$, $AB = 18$ cm and $BC = 15$ cm, then PR is equal to
- (A) 10 cm (B) 12 cm (C) $\frac{20}{3}$ cm (D) 8 cm
12. If S is a point on side PQ of a ΔPQR such that $PS = QS = RS$, then
- (A) $PR \cdot QR = RS^2$ (B) $QS^2 + RS^2 = QR^2$
 (C) $PR^2 + QR^2 = PQ^2$ (D) $PS^2 + RS^2 = PR^2$

(C) Short Answer Questions with Reasoning

Sample Question 1: In $\triangle ABC$, $AB = 24$ cm, $BC = 10$ cm and $AC = 26$ cm. Is this triangle a right triangle? Give reasons for your answer.

Solution : Here $AB^2 = 576$, $BC^2 = 100$ and $AC^2 = 676$. So, $AC^2 = AB^2 + BC^2$

Hence, the given triangle is a right triangle.

Sample Question 2: P and Q are the points on the sides DE and DF of a triangle DEF such that $DP = 5$ cm, $DE = 15$ cm, $DQ = 6$ cm and $QF = 18$ cm. Is $PQ \parallel EF$? Give reasons for your answer.

Solution : Here, $\frac{DP}{PE} = \frac{5}{15-5} = \frac{1}{2}$ and $\frac{DQ}{QF} = \frac{6}{18} = \frac{1}{3}$

As $\frac{DP}{PE} \neq \frac{DQ}{QF}$, therefore PQ is not parallel to EF.

Sample Question 3: It is given that $\triangle FED \sim \triangle STU$. Is it true to say that $\frac{DE}{ST} = \frac{EF}{TU}$? Why?

Solution : No, because the correct correspondence is $F \leftrightarrow S$, $E \leftrightarrow T$, $D \leftrightarrow U$.

With this correspondence, $\frac{EF}{ST} = \frac{DE}{TU}$.

EXERCISE 6.2

1. Is the triangle with sides 25 cm, 5 cm and 24 cm a right triangle? Give reasons for your answer.
2. It is given that $\triangle DEF \sim \triangle RPQ$. Is it true to say that $\angle D = \angle R$ and $\angle F = \angle P$? Why?
3. A and B are respectively the points on the sides PQ and PR of a triangle PQR

such that $PQ = 12.5$ cm, $PA = 5$ cm, $BR = 6$ cm and $PB = 4$ cm. Is $AB \parallel QR$? Give reasons for your answer.

4. In Fig 6.4, BD and CE intersect each other at the point P . Is $\triangle PBC \sim \triangle PDE$? Why?

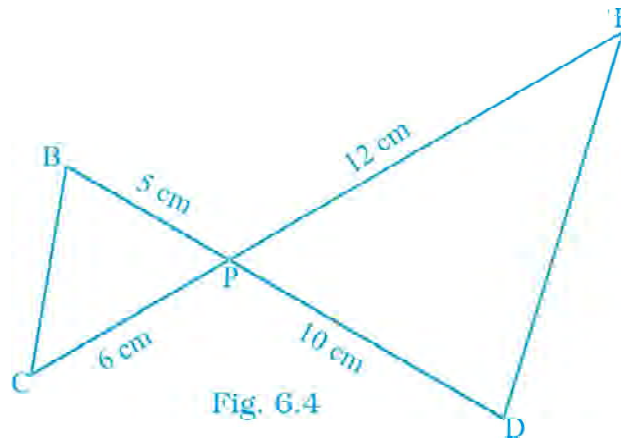

5. In triangles PQR and MST , $\angle P = 55^\circ$, $\angle Q = 25^\circ$, $\angle M = 100^\circ$ and $\angle S = 25^\circ$. Is $\triangle PQR \sim \triangle MST$? Why?
6. Is the following statement true? Why?
- “Two quadrilaterals are similar, if their corresponding angles are equal”.
7. Two sides and the perimeter of one triangle are respectively three times the corresponding sides and the perimeter of the other triangle. Are the two triangles similar? Why?
8. If in two right triangles, one of the acute angles of one triangle is equal to an acute angle of the other triangle, can you say that the two triangles will be similar? Why?
9. The ratio of the corresponding altitudes of two similar triangles is $\frac{3}{5}$. Is it correct to say that ratio of their areas is $\frac{6}{5}$? Why?

10. D is a point on side QR of ΔPQR such that $PD \perp QR$. Will it be correct to say that $\Delta PQD \sim \Delta RPD$? Why?
11. In Fig. 6.5, if $\angle D = \angle C$, then is it true that $\Delta ADE \sim \Delta ACB$? Why?
12. Is it true to say that if in two triangles, an angle of one triangle is equal to an angle of another triangle and two sides of one triangle are proportional to the two sides of the other triangle, then the triangles are similar? Give reasons for your answer.

(D) Short Answer Questions

Sample Question 1: Legs (sides other than the hypotenuse) of a right triangle are of lengths 16cm and 8 cm. Find the length of the side of the largest square that can be inscribed in the triangle.

Solution: Let ABC be a right triangle right angled at B with $AB = 16$ cm and $BC = 8$ cm. Then, the largest square BRSP which can be inscribed in this triangle will be as shown in Fig.6.6.

Let $PB = x$ cm. So., $AP = (16-x)$ cm. In ΔAPS and ΔABC , $\angle A = \angle A$ and $\angle APS = \angle ABC$ (Each 90°)

So, $\Delta APS \sim \Delta ABC$ (AA similarity)

$$\text{Therefore, } \frac{AP}{AB} = \frac{PS}{BC}$$

$$\text{or } \frac{16-x}{16} = \frac{x}{8}$$

$$\text{or } 128 - 8x = 16x$$

$$\text{or } x = \frac{128}{24} = \frac{16}{3}$$

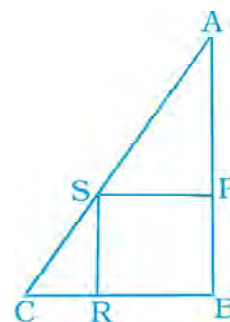

Fig. 6.6

Thus, the side of the required square is of length $\frac{16}{3}$ cm.

Sample Question 2: Hypotenuse of a right triangle is 25 cm and out of the remaining two sides, one is longer than the other by 5 cm. Find the lengths of the other two sides.

Solution : Let one side be x cm. Then the other side will be $(x + 5)$ cm.

Therefore, from Pythagoras Theorem

$$x^2 + (x + 5)^2 = (25)^2$$

or $x^2 + x^2 + 10x + 25 = 625$

or $x^2 + 5x - 300 = 0$

or $x^2 + 20x - 15x - 300 = 0$

or $x(x+20) - 15(x+20) = 0$

or $(x-15)(x+20) = 0$

So, $x = 15$ or $x = -20$

Rejecting $x = -20$, we have length of one side = 15 cm and that of the other side = $(15 + 5)$ cm = 20 cm

Sample Question 3: In Fig 6.7,

$\angle D = \angle E$ and $\frac{AD}{DB} = \frac{AE}{EC}$. Prove that $\triangle BAC$ is an isosceles triangle.

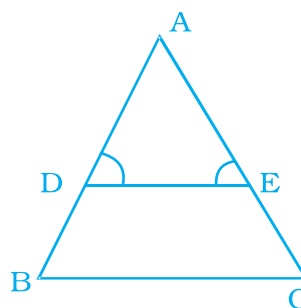

Fig. 6.7

Solution : $\frac{AD}{DB} = \frac{AE}{EC}$ (Given)

Therefore, $DE \parallel BC$ (Converse of Basic Proportionality Theorem)

So, $\angle D = \angle B$ and $\angle E = \angle C$ (Corresponding angles) (1)

But $\angle D = \angle E$ (Given)

Therefore, $\angle B = \angle C$ [From (1)]

So, $AB = AC$ (Sides opposite to equal angles)

i.e., $\triangle BAC$ is an isosceles triangle.

EXERCISE 6.3

1. In a $\triangle PQR$, $PR^2 - PQ^2 = QR^2$ and M is a point on side PR such that $QM \perp PR$. Prove that

$$QM^2 = PM \times MR.$$

2. Find the value of x for which $DE \parallel AB$ in Fig. 6.8.

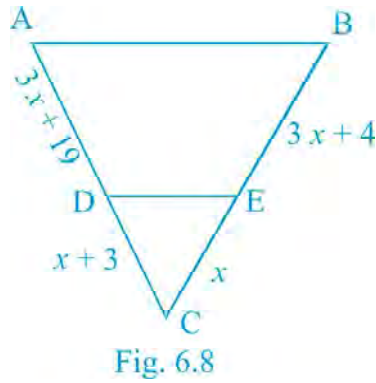

3. In Fig. 6.9, if $\angle 1 = \angle 2$ and $\triangle NSQ \cong \triangle MTR$, then prove that $\triangle PTS \sim \triangle PRQ$.

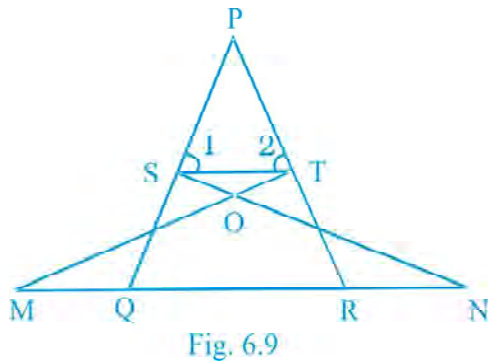

4. Diagonals of a trapezium PQRS intersect each other at the point O, $PQ \parallel RS$ and $PQ = 3 RS$. Find the ratio of the areas of triangles POQ and ROS.
5. In Fig. 6.10, if $AB \parallel DC$ and AC and PQ intersect each other at the point O, prove that $OA \cdot CQ = OC \cdot AP$.

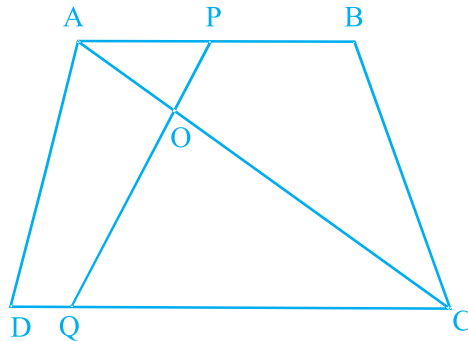

Fig. 6.10

6. Find the altitude of an equilateral triangle of side 8 cm.
7. If $\triangle ABC \sim \triangle DEF$, $AB = 4$ cm, $DE = 6$ cm, $EF = 9$ cm and $FD = 12$ cm, find the perimeter of $\triangle ABC$.
8. In Fig. 6.11, if $DE \parallel BC$, find the ratio of ar (ADE) and ar (DECB).

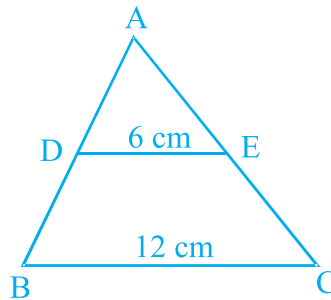

Fig. 6.11

9. ABCD is a trapezium in which $AB \parallel DC$ and P and Q are points on AD and BC, respectively such that $PQ \parallel DC$. If $PD = 18$ cm, $BQ = 35$ cm and $QC = 15$ cm, find AD.
10. Corresponding sides of two similar triangles are in the ratio of 2 : 3. If the area of the smaller triangle is 48 cm^2 , find the area of the larger triangle.
11. In a triangle PQR, N is a point on PR such that $QN \perp PR$. If $PN \cdot NR = QN^2$, prove that $\angle PQR = 90^\circ$.

12. Areas of two similar triangles are 36 cm^2 and 100 cm^2 . If the length of a side of the larger triangle is 20 cm, find the length of the corresponding side of the smaller triangle.
13. In Fig. 6.12, if $\angle ACB = \angle CDA$, $AC = 8 \text{ cm}$ and $AD = 3 \text{ cm}$, find BD .

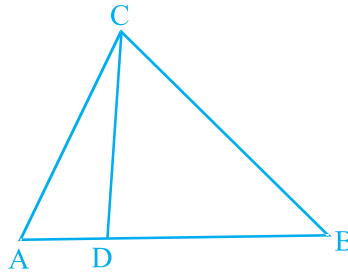

Fig. 6.12

14. A 15 metres high tower casts a shadow 24 metres long at a certain time and at the same time, a telephone pole casts a shadow 16 metres long. Find the height of the telephone pole.
15. Foot of a 10 m long ladder leaning against a vertical wall is 6 m away from the base of the wall. Find the height of the point on the wall where the top of the ladder reaches.

(E) Long Answer Questions

Sample Question 1: In Fig 6.13, OB is the perpendicular bisector of the line segment DE , $FA \perp OB$ and $F E$ intersects OB at the point C . Prove that

$$\frac{1}{OA} + \frac{1}{OB} = \frac{2}{OC}$$

Solution: In $\triangle AOF$ and $\triangle BOD$.

$\angle O = \angle O$ (Same angle) and $\angle A = \angle B$ (each 90°)

Therefore, $\triangle AOF \sim \triangle BOD$ (AA similarity)

So,
$$\frac{OA}{OB} = \frac{FA}{DB} \tag{1}$$

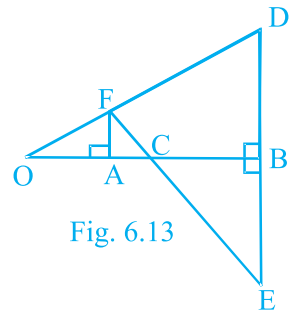

Fig. 6.13

Also, in ΔFAC and ΔEBC , $\angle A = \angle B$ (Each 90°)

and $\angle FCA = \angle ECB$ (Vertically opposite angles).

Therefore, $\Delta FAC \sim \Delta EBC$ (AA similarity).

$$\text{So, } \frac{FA}{EB} = \frac{AC}{BC}$$

But $EB = DB$ (B is mid-point of DE)

$$\text{So, } \frac{FA}{DB} = \frac{AC}{BC} \quad (2)$$

Therefore, from (1) and (2), we have:

$$\frac{AC}{BC} = \frac{OA}{OB}$$

$$\text{i.e., } \frac{OC - OA}{OB - OC} = \frac{OA}{OB}$$

$$\text{or } OB \cdot OC - OA \cdot OB = OA \cdot OB - OA \cdot OC$$

$$\text{or } OB \cdot OC + OA \cdot OC = 2 OA \cdot OB$$

$$\text{or } (OB + OA) \cdot OC = 2 OA \cdot OB$$

$$\text{or } \frac{1}{OA} + \frac{1}{OB} = \frac{2}{OC} \quad [\text{Dividing both the sides by } OA \cdot OB \cdot OC]$$

Sample Question 2: Prove that if in a triangle square on one side is equal to the sum of the squares on the other two sides, then the angle opposite the first side is a right angle.

Solution: See proof of Theorem 6.9 of Mathematics Textbook for Class X.

Sample Question 3: An aeroplane leaves an Airport and flies due North at 300 km/h. At the same time, another aeroplane leaves the same Airport and flies due West at 400 km/h. How far apart the two aeroplanes would be after $1\frac{1}{2}$ hours?

Solution: Distance travelled by first aeroplane in $1\frac{1}{2}$ hours = $300 \times \frac{3}{2}$ km = 450 km

and that by second aeroplane = $\frac{400 \times 3}{2}$ km = 600 km

Position of the two aeroplanes after $1\frac{1}{2}$ hours would be A and B as shown in Fig. 6.14.

That is, OA = 450 km and OB = 600 km.

From ΔAOB , we have

$$AB^2 = OA^2 + OB^2$$

or $AB^2 = (450)^2 + (600)^2$

$$= (150)^2 \times 3^2 + (150)^2 \times 4^2$$

$$= 150^2 (3^2 + 4^2)$$

$$= 150^2 \times 5^2$$

or $AB = 150 \times 5 = 750$

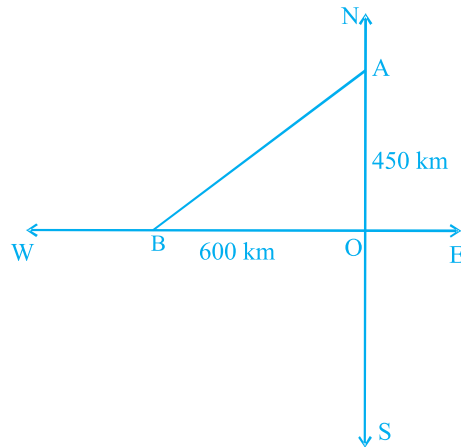

Fig. 6.14

Thus, the two aeroplanes will be 750 km apart after $1\frac{1}{2}$ hours.

Sample Question 4: In Fig. 6.15, if $\Delta ABC \sim \Delta DEF$ and their sides are of lengths (in cm) as marked along them, then find the lengths of the sides of each triangle.

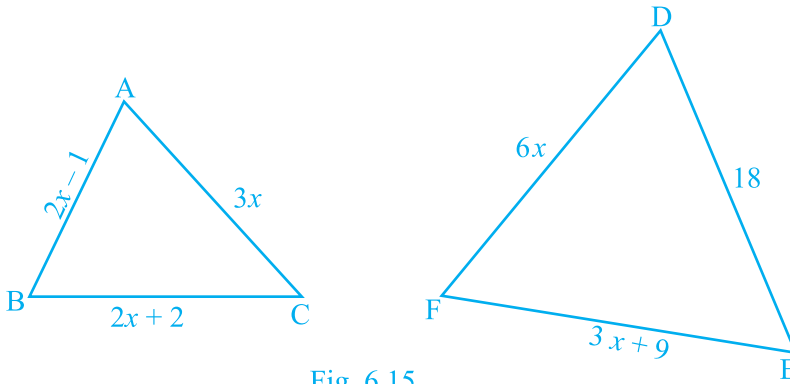

Fig. 6.15

Solution: $\triangle ABC \sim \triangle DEF$ (Given)

$$\text{Therefore, } \frac{AB}{DE} = \frac{BC}{EF} = \frac{CA}{FD}$$

$$\text{So, } \frac{2x-1}{18} = \frac{2x+2}{3x+9} = \frac{3x}{6x}$$

Now, taking $\frac{2x-1}{18} = \frac{3x}{6x}$, we have

$$\frac{2x-1}{18} = \frac{1}{2}$$

$$\text{or } 4x - 2 = 18$$

$$\text{or } x = 5$$

Therefore, $AB = 2 \times 5 - 1 = 9$, $BC = 2 \times 5 + 2 = 12$,

$$CA = 3 \times 5 = 15, DE = 18, EF = 3 \times 5 + 9 = 24 \text{ and } FD = 6 \times 5 = 30$$

Hence, $AB = 9$ cm, $BC = 12$ cm, $CA = 15$ cm,

$$DE = 18$$
 cm, $EF = 24$ cm and $FD = 30$ cm.

EXERCISE 6.4

- In Fig. 6.16, if $\angle A = \angle C$, $AB = 6$ cm, $BP = 15$ cm, $AP = 12$ cm and $CP = 4$ cm, then find the lengths of PD and CD .
- It is given that $\triangle ABC \sim \triangle EDF$ such that $AB = 5$ cm, $AC = 7$ cm, $DF = 15$ cm and $DE = 12$ cm. Find the lengths of the remaining sides of the triangles.
- Prove that if a line is drawn parallel to one side of a triangle to intersect the other two sides, then the two sides are divided in the same ratio.
- In Fig 6.17, if $PQRS$ is a parallelogram and $AB \parallel PS$, then prove that $OC \parallel SR$.

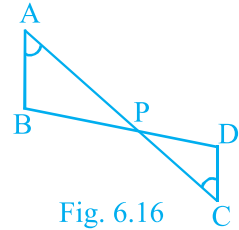

Fig. 6.16

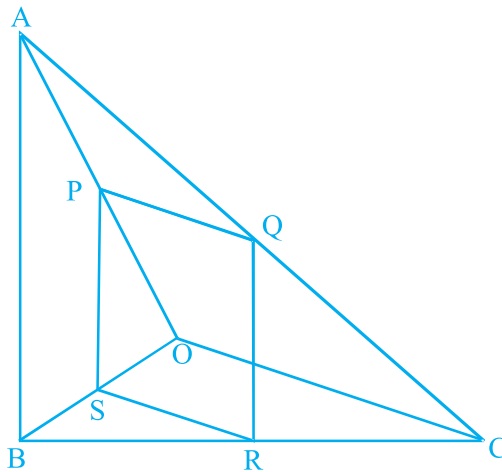

Fig. 6.17

- A 5 m long ladder is placed leaning towards a vertical wall such that it reaches the wall at a point 4 m high. If the foot of the ladder is moved 1.6 m towards the wall, then find the distance by which the top of the ladder would slide upwards on the wall.
- For going to a city B from city A, there is a route via city C such that $AC \perp CB$, $AC = 2x$ km and $CB = 2(x + 7)$ km. It is proposed to construct a 26 km highway which directly connects the two cities A and B. Find how much distance will be saved in reaching city B from city A after the construction of the highway.

7. A flag pole 18 m high casts a shadow 9.6 m long. Find the distance of the top of the pole from the far end of the shadow.
8. A street light bulb is fixed on a pole 6 m above the level of the street. If a woman of height 1.5 m casts a shadow of 3m, find how far she is away from the base of the pole.
9. In Fig. 6.18, ABC is a triangle right angled at B and $BD \perp AC$. If $AD = 4$ cm, and $CD = 5$ cm, find BD and AB .

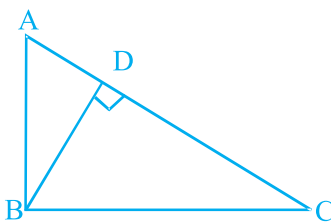

Fig. 6.18

10. In Fig. 6.19, PQR is a right triangle right angled at Q and $QS \perp PR$. If $PQ = 6$ cm and $PS = 4$ cm, find QS , RS and QR .

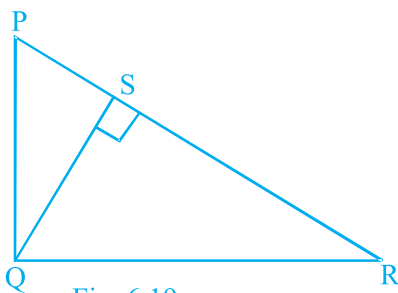

Fig. 6.19

11. In $\triangle PQR$, $PD \perp QR$ such that D lies on QR . If $PQ = a$, $PR = b$, $QD = c$ and $DR = d$, prove that $(a + b)(a - b) = (c + d)(c - d)$.
12. In a quadrilateral $ABCD$, $\angle A + \angle D = 90^\circ$. Prove that $AC^2 + BD^2 = AD^2 + BC^2$
[Hint: Produce AB and DC to meet at E .]

13. In fig. 6.20, $l \parallel m$ and line segments AB, CD and EF are concurrent at point P.

Prove that $\frac{AE}{BF} = \frac{AC}{BD} = \frac{CE}{FD}$.

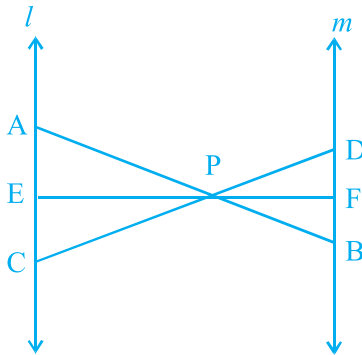

Fig. 6.20

14. In Fig. 6.21, PA, QB, RC and SD are all perpendiculars to a line l , AB = 6 cm, BC = 9 cm, CD = 12 cm and SP = 36 cm. Find PQ, QR and RS.

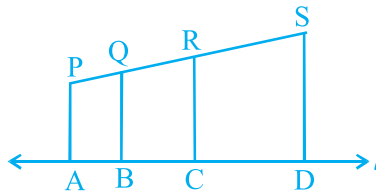

Fig. 6.21

15. O is the point of intersection of the diagonals AC and BD of a trapezium ABCD with $AB \parallel DC$. Through O, a line segment PQ is drawn parallel to AB meeting AD in P and BC in Q. Prove that $PO = QO$.
16. In Fig. 6.22, line segment DF intersect the side AC of a triangle ABC at the point E such that E is the mid-point of CA and $\angle AEF = \angle AFE$. Prove that

$$\frac{BD}{CD} = \frac{BF}{CE}$$

[Hint: Take point G on AB such that $CG \parallel DF$.]

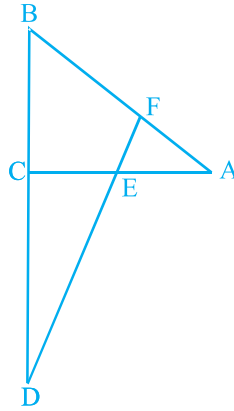

Fig. 6.22

17. Prove that the area of the semicircle drawn on the hypotenuse of a right angled triangle is equal to the sum of the areas of the semicircles drawn on the other two sides of the triangle.
18. Prove that the area of the equilateral triangle drawn on the hypotenuse of a right angled triangle is equal to the sum of the areas of the equilateral triangles drawn on the other two sides of the triangle.

COORDINATE GEOMETRY

(A) Main Concepts and Results

Distance Formula, Section Formula, Area of a Triangle.

- The distance between two points P (x_1, y_1) and Q (x_2, y_2) is

$$\sqrt{(x_2 - x_1)^2 + (y_2 - y_1)^2}$$

- The distance of a point P (x, y) from the origin is $\sqrt{x^2 + y^2}$
- The coordinates of the point P which divides the line segment joining the points A (x_1, y_1) and B (x_2, y_2) internally in the ratio $m_1 : m_2$ are

$$\left(\frac{m_1 x_2 + m_2 x_1}{m_1 + m_2}, \frac{m_1 y_2 + m_2 y_1}{m_1 + m_2} \right)$$

- The coordinates of the mid-point of the line segment joining the points P (x_1, y_1)

and Q (x_2, y_2) are $\left(\frac{x_1 + x_2}{2}, \frac{y_1 + y_2}{2} \right)$

- The area of a triangle with vertices A (x_1, y_1) , B (x_2, y_2) and C (x_3, y_3) is

$$\frac{1}{2} [x_1 (y_2 - y_3) + x_2 (y_3 - y_1) + x_3 (y_1 - y_2)]$$

which is non-zero unless the points A, B and C are collinear.

(B) Multiple Choice Questions

Choose the correct answer from the given four options:

Sample Question 1: If the distance between the points $(2, -2)$ and $(-1, x)$ is 5, one of the values of x is

- (A) -2 (B) 2 (C) -1 (D) 1

Solution : Answer (B)

Sample Question 2: The mid-point of the line segment joining the points $A(-2, 8)$ and $B(-6, -4)$ is

- (A) $(-4, -6)$ (B) $(2, 6)$ (C) $(-4, 2)$ (D) $(4, 2)$

Solution : Answer (C)

Sample Question 3: The points $A(9, 0)$, $B(9, 6)$, $C(-9, 6)$ and $D(-9, 0)$ are the vertices of a

- (A) square (B) rectangle (C) rhombus (D) trapezium

Solution : Answer (B)

EXERCISE 7.1

Choose the correct answer from the given four options:

- The distance of the point $P(2, 3)$ from the x -axis is
(A) 2 (B) 3 (C) 1 (D) 5
- The distance between the points $A(0, 6)$ and $B(0, -2)$ is
(A) 6 (B) 8 (C) 4 (D) 2
- The distance of the point $P(-6, 8)$ from the origin is
(A) 8 (B) $2\sqrt{7}$ (C) 10 (D) 6
- The distance between the points $(0, 5)$ and $(-5, 0)$ is
(A) 5 (B) $5\sqrt{2}$ (C) $2\sqrt{5}$ (D) 10
- AOBC is a rectangle whose three vertices are vertices $A(0, 3)$, $O(0, 0)$ and $B(5, 0)$. The length of its diagonal is
(A) 5 (B) 3 (C) $\sqrt{34}$ (D) 4
- The perimeter of a triangle with vertices $(0, 4)$, $(0, 0)$ and $(3, 0)$ is
(A) 5 (B) 12 (C) 11 (D) $7+\sqrt{5}$
- The area of a triangle with vertices $A(3, 0)$, $B(7, 0)$ and $C(8, 4)$ is
(A) 14 (B) 28 (C) 8 (D) 6
- The points $(-4, 0)$, $(4, 0)$, $(0, 3)$ are the vertices of a
(A) right triangle (B) isosceles triangle
(C) equilateral triangle (D) scalene triangle

9. The point which divides the line segment joining the points (7, -6) and (3, 4) in ratio 1 : 2 internally lies in the
 (A) I quadrant (B) II quadrant
 (C) III quadrant (D) IV quadrant
10. The point which lies on the perpendicular bisector of the line segment joining the points A (-2, -5) and B (2, 5) is
 (A) (0, 0) (B) (0, 2) (C) (2, 0) (D) (-2, 0)
11. The fourth vertex D of a parallelogram ABCD whose three vertices are A (-2, 3), B (6, 7) and C (8, 3) is
 (A) (0, 1) (B) (0, -1) (C) (-1, 0) (D) (1, 0)
12. If the point P (2, 1) lies on the line segment joining points A (4, 2) and B (8, 4), then
 (A) $AP = \frac{1}{3} AB$ (B) $AP = PB$ (C) $PB = \frac{1}{3} AB$ (D) $AP = \frac{1}{2} AB$

13. If P $\left(\frac{a}{3}, 4\right)$ is the mid-point of the line segment joining the points Q (-6, 5) and R (-2, 3), then the value of a is
 (A) -4 (B) -12 (C) 12 (D) -6

14. The perpendicular bisector of the line segment joining the points A (1, 5) and B (4, 6) cuts the y-axis at
 (A) (0, 13) (B) (0, -13)
 (C) (0, 12) (D) (13, 0)

15. The coordinates of the point which is equidistant from the three vertices of the ΔAOB as shown in the Fig. 7.1 is
 (A) (x, y) (B) (y, x)
 (C) $\frac{x}{2}, \frac{y}{2}$ (D) $\frac{y}{2}, \frac{x}{2}$

16. A circle drawn with origin as the centre passes through $\left(\frac{13}{2}, 0\right)$. The point which does not lie in the interior of the circle is

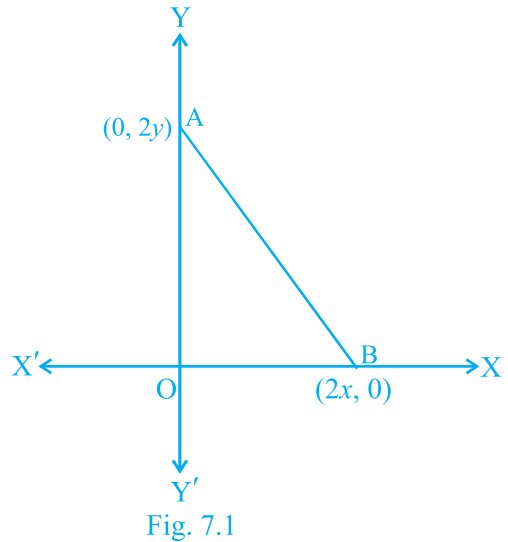

(A) $\frac{-3}{4}, 1$ (B) $2, \frac{7}{3}$ (C) $5, \frac{-1}{2}$ (D) $\left(-6, \frac{5}{2}\right)$

17. A line intersects the y -axis and x -axis at the points P and Q, respectively. If $(2, -5)$ is the mid-point of PQ, then the coordinates of P and Q are, respectively
 (A) $(0, -5)$ and $(2, 0)$ (B) $(0, 10)$ and $(-4, 0)$
 (C) $(0, 4)$ and $(-10, 0)$ (D) $(0, -10)$ and $(4, 0)$
18. The area of a triangle with vertices $(a, b + c)$, $(b, c + a)$ and $(c, a + b)$ is
 (A) $(a + b + c)^2$ (B) 0 (C) $a + b + c$ (D) abc
19. If the distance between the points $(4, p)$ and $(1, 0)$ is 5, then the value of p is
 (A) 4 only (B) ± 4 (C) -4 only (D) 0
20. If the points A $(1, 2)$, O $(0, 0)$ and C (a, b) are collinear, then
 (A) $a = b$ (B) $a = 2b$ (C) $2a = b$ (D) $a = -b$

(C) Short Answer Questions with Reasoning

State whether the following statements are true or false. Justify your answer.

Sample Question 1 : The points A $(-1, 0)$, B $(3, 1)$, C $(2, 2)$ and D $(-2, 1)$ are the vertices of a parallelogram.

Solution : True. The coordinates of the mid-points of both the diagonals AC and BD are $\frac{1}{2}, 1$, i.e., the diagonals bisect each other.

Sample Question 2 : The points $(4, 5)$, $(7, 6)$ and $(6, 3)$ are collinear.

Solution : False. Since the area of the triangle formed by the points is 4 sq. units, the points are not collinear.

Sample Question 3 : Point P $(0, -7)$ is the point of intersection of y -axis and perpendicular bisector of line segment joining the points A $(-1, 0)$ and B $(7, -6)$.

Solution : True. P $(0, -7)$ lies on the y -axis. It is at a distance of $\sqrt{50}$ units from both the points $(-1, 0)$ and $(7, -6)$.

EXERCISE 7.2

State whether the following statements are true or false. Justify your answer.

1. $\triangle ABC$ with vertices A $(-2, 0)$, B $(2, 0)$ and C $(0, 2)$ is similar to $\triangle DEF$ with vertices D $(-4, 0)$ E $(4, 0)$ and F $(0, 4)$.

2. Point P (-4, 2) lies on the line segment joining the points A (-4, 6) and B (-4, -6).
3. The points (0, 5), (0, -9) and (3, 6) are collinear.
4. Point P (0, 2) is the point of intersection of y-axis and perpendicular bisector of line segment joining the points A (-1, 1) and B (3, 3).
5. Points A (3, 1), B (12, -2) and C (0, 2) cannot be the vertices of a triangle.
6. Points A (4, 3), B (6, 4), C (5, -6) and D (-3, 5) are the vertices of a parallelogram.
7. A circle has its centre at the origin and a point P (5, 0) lies on it. The point Q (6, 8) lies outside the circle.
8. The point A (2, 7) lies on the perpendicular bisector of line segment joining the points P (6, 5) and Q (0, -4).
9. Point P (5, -3) is one of the two points of trisection of the line segment joining the points A (7, -2) and B (1, -5).
10. Points A (-6, 10), B (-4, 6) and C (3, -8) are collinear such that $AB = \frac{2}{9}AC$.
11. The point P (-2, 4) lies on a circle of radius 6 and centre C (3, 5).
12. The points A (-1, -2), B (4, 3), C (2, 5) and D (-3, 0) in that order form a rectangle.

(D) Short Answer Questions

Sample Question 1 : If the mid-point of the line segment joining the points A (3, 4) and B (k, 6) is P (x, y) and $x + y - 10 = 0$, find the value of k.

Solution : Mid-point of the line segment joining A (3, 4) and B (k, 6) = $\frac{3+k}{2}, \frac{4+6}{2}$

$$= \frac{3+k}{2}, 5$$

Then, $\frac{3+k}{2}, 5 = (x, y)$

Therefore, $\frac{3+k}{2} = x$ and $5 = y$.

Since $x + y - 10 = 0$, we have

$$\frac{3+k}{2} + 5 - 10 = 0$$

i.e., $3 + k = 10$

Therefore, $k = 7$.

Sample Question 2 : Find the area of the triangle ABC with A (1, -4) and the mid-points of sides through A being (2, -1) and (0, -1).

Solution: Let the coordinates of B and C be (a, b) and (x, y) , respectively.

$$\text{Then, } \left(\frac{1+a}{2}, \frac{-4+b}{2} \right) = (2, -1)$$

$$\text{Therefore, } \begin{array}{l} 1+a=4, \quad -4+b=-2 \\ a=3 \quad \quad b=2 \end{array}$$

$$\text{Also, } \left(\frac{1+x}{2}, \frac{-4+y}{2} \right) = (0, -1)$$

$$\text{Therefore, } \begin{array}{l} 1+x=0, \quad -4+y=-2 \\ \text{i.e., } \quad x=-1 \quad \text{i.e., } y=2 \end{array}$$

The coordinates of the vertices of ΔABC are A (1, -4), B (3, 2) and C (-1, 2).

$$\begin{aligned} \text{Area of } \Delta ABC &= \frac{1}{2} [1(2-2) + 3(2+4) - 1(-4-2)] \\ &= \frac{1}{2} [18 + 6] \\ &= 12 \text{ sq. units.} \end{aligned}$$

Sample Question 3 : Name the type of triangle PQR formed by the points P $(\sqrt{2}, \sqrt{2})$, Q $(-\sqrt{2}, -\sqrt{2})$ and R $(-\sqrt{6}, \sqrt{6})$.

Solution : Using distance formula

$$PQ = \sqrt{(\sqrt{2} + \sqrt{2})^2 + (\sqrt{2} + \sqrt{2})^2} = \sqrt{(2\sqrt{2})^2 + (2\sqrt{2})^2} = \sqrt{16} = 4$$

$$PR = \sqrt{(\sqrt{2} + \sqrt{6})^2 + (\sqrt{2} - \sqrt{6})^2} = \sqrt{2 + 6 + 2\sqrt{12} + 2 + 6 - 2\sqrt{12}} = \sqrt{16} = 4$$

$$RQ = \sqrt{(-\sqrt{2} + \sqrt{6})^2 + (-\sqrt{2} - \sqrt{6})^2} = \sqrt{2 + 6 - 2\sqrt{12} + 2 + 6 + 2\sqrt{12}} = \sqrt{16} = 4$$

Since $PQ = PR = RQ = 4$, points P, Q, R form an equilateral triangle.

Sample Question 4 : ABCD is a parallelogram with vertices A (x_1, y_1) , B (x_2, y_2) and C (x_3, y_3) . Find the coordinates of the fourth vertex D in terms of x_1, x_2, x_3, y_1, y_2 and y_3 .

Solution: Let the coordinates of D be (x, y) . We know that diagonals of a parallelogram bisect each other.

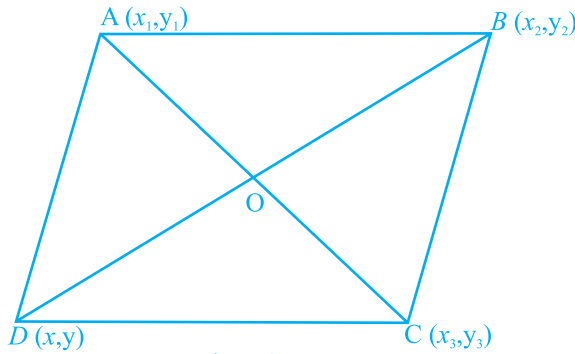

Fig. 7.2

Therefore, mid-point of AC = mid-point of BD $\frac{x_1 + x_3}{2}, \frac{y_1 + y_3}{2} = \frac{x_2 + x}{2}, \frac{y_2 + y}{2}$

i.e., $x_1 + x_3 = x_2 + x$ and $y_1 + y_3 = y_2 + y$

i.e., $x_1 + x_3 - x_2 = x$ and $y_1 + y_3 - y_2 = y$

Thus, the coordinates of D are

$(x_1 + x_3 - x_2, y_1 + y_3 - y_2)$

EXERCISE 7.3

1. Name the type of triangle formed by the points A $(-5, 6)$, B $(-4, -2)$ and C $(7, 5)$.
2. Find the points on the x -axis which are at a distance of $2\sqrt{5}$ from the point $(7, -4)$. How many such points are there?
3. What type of a quadrilateral do the points A $(2, -2)$, B $(7, 3)$, C $(11, -1)$ and D $(6, -6)$ taken in that order, form?
4. Find the value of a , if the distance between the points A $(-3, -14)$ and B $(a, -5)$ is 9 units.
5. Find a point which is equidistant from the points A $(-5, 4)$ and B $(-1, 6)$? How many such points are there?

6. Find the coordinates of the point Q on the x -axis which lies on the perpendicular bisector of the line segment joining the points A $(-5, -2)$ and B $(4, -2)$. Name the type of triangle formed by the points Q, A and B.
7. Find the value of m if the points $(5, 1)$, $(-2, -3)$ and $(8, 2m)$ are collinear.
8. If the point A $(2, -4)$ is equidistant from P $(3, 8)$ and Q $(-10, y)$, find the values of y . Also find distance PQ.
9. Find the area of the triangle whose vertices are $(-8, 4)$, $(-6, 6)$ and $(-3, 9)$.
10. In what ratio does the x -axis divide the line segment joining the points $(-4, -6)$ and $(-1, 7)$? Find the coordinates of the point of division.
11. Find the ratio in which the point $P\left(\frac{3}{4}, \frac{5}{12}\right)$ divides the line segment joining the points A $\frac{1}{2}, \frac{3}{2}$ and B $(2, -5)$.
12. If P $(9a - 2, -b)$ divides line segment joining A $(3a + 1, -3)$ and B $(8a, 5)$ in the ratio $3 : 1$, find the values of a and b .
13. If (a, b) is the mid-point of the line segment joining the points A $(10, -6)$ and B $(k, 4)$ and $a - 2b = 18$, find the value of k and the distance AB.
14. The centre of a circle is $(2a, a - 7)$. Find the values of a if the circle passes through the point $(11, -9)$ and has diameter $10\sqrt{2}$ units.
15. The line segment joining the points A $(3, 2)$ and B $(5, 1)$ is divided at the point P in the ratio $1:2$ and it lies on the line $3x - 18y + k = 0$. Find the value of k .
16. If D $\left(\frac{-1}{2}, \frac{5}{2}\right)$, E $(7, 3)$ and F $\left(\frac{7}{2}, \frac{7}{2}\right)$ are the midpoints of sides of ΔABC , find the area of the ΔABC .
17. The points A $(2, 9)$, B $(a, 5)$ and C $(5, 5)$ are the vertices of a triangle ABC right angled at B. Find the values of a and hence the area of ΔABC .
18. Find the coordinates of the point R on the line segment joining the points P $(-1, 3)$ and Q $(2, 5)$ such that $PR = \frac{3}{5}PQ$.
19. Find the values of k if the points A $(k + 1, 2k)$, B $(3k, 2k + 3)$ and C $(5k - 1, 5k)$ are collinear.
20. Find the ratio in which the line $2x + 3y - 5 = 0$ divides the line segment joining the points $(8, -9)$ and $(2, 1)$. Also find the coordinates of the point of division.

(E) Long Answer Questions

Sample Question 1 : The mid-points D, E, F of the sides of a triangle ABC are (3, 4), (8, 9) and (6, 7). Find the coordinates of the vertices of the triangle.

Solution : Since D and F are the mid-points of AB and AC, respectively, by mid-point theorem, we can prove that DFEB is a parallelogram. Let the coordinates of B be (x, y).

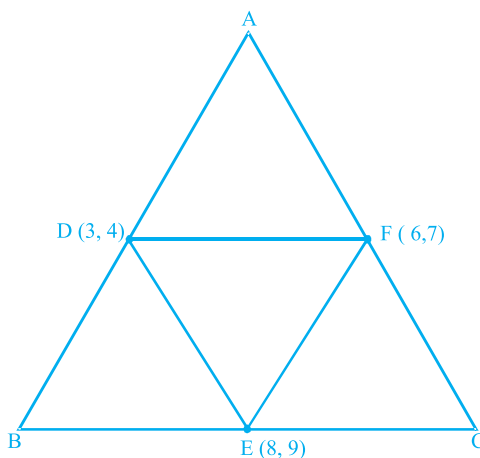

Fig. 7.3

Refer to Sample Question 4 of Section (D) to get

$$x = 3 + 8 - 6 = 5$$

$$y = 4 + 9 - 7 = 6$$

Therefore, B (5, 6) is one of the vertices of the triangle.

Similarly DFCE and DAFE are also parallelograms, and the coordinates of A are $(3 + 6 - 8, 4 + 7 - 9) = (1, 2)$. Coordinates of C are $(8 + 6 - 3, 9 + 7 - 4) = (11, 12)$. Thus, the coordinates of the vertices of the triangle are A (1, 2), B (5, 6) and C (11, 12).

EXERCISE 7.4

1. If $(-4, 3)$ and $(4, 3)$ are two vertices of an equilateral triangle, find the coordinates of the third vertex, given that the origin lies in the interior of the triangle.
2. A (6, 1), B (8, 2) and C (9, 4) are three vertices of a parallelogram ABCD. If E is the midpoint of DC, find the area of $\triangle ADE$.

3. The points $A(x_1, y_1)$, $B(x_2, y_2)$ and $C(x_3, y_3)$ are the vertices of ΔABC .
- The median from A meets BC at D. Find the coordinates of the point D.
 - Find the coordinates of the point P on AD such that $AP : PD = 2 : 1$
 - Find the coordinates of points Q and R on medians BE and CF, respectively such that $BQ : QE = 2 : 1$ and $CR : RF = 2 : 1$
 - What are the coordinates of the centroid of the triangle ABC?
4. If the points A (1, -2), B (2, 3) C (a, 2) and D (-4, -3) form a parallelogram, find the value of a and height of the parallelogram taking AB as base.
5. Students of a school are standing in rows and columns in their playground for a drill practice. A, B, C and D are the positions of four students as shown in figure 7.4. Is it possible to place Jaspal in the drill in such a way that he is equidistant from each of the four students A, B, C and D? If so, what should be his position?

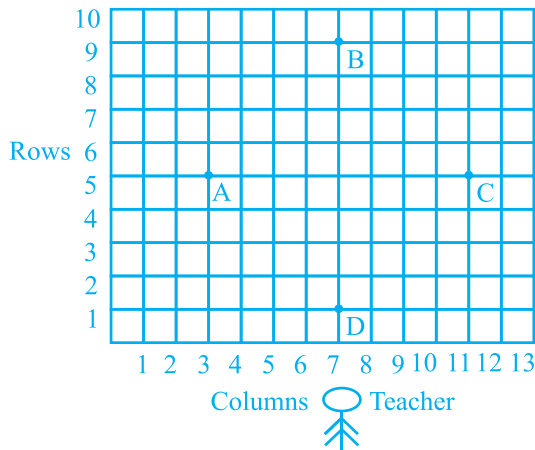

Fig. 7.4

6. Ayush starts walking from his house to office. Instead of going to the office directly, he goes to a bank first, from there to his daughter's school and then reaches the office. What is the extra distance travelled by Ayush in reaching his office? (Assume that all distances covered are in straight lines).

If the house is situated at (2, 4), bank at (5, 8), school at (13, 14) and office at (13, 26) and coordinates are in km.

INTRODUCTION TO TRIGONOMETRY AND ITS APPLICATIONS

(A) Main Concepts and Results

- Trigonometric Ratios of the angle A in a triangle ABC right angled at B are defined as:

$$\text{sine of } \angle A = \sin A = \frac{\text{side opposite to } \angle A}{\text{hypotenuse}} = \frac{BC}{AC}$$

$$\text{cosine of } \angle A = \cos A = \frac{\text{side adjacent to } \angle A}{\text{hypotenuse}} = \frac{AB}{AC}$$

$$\text{tangent of } \angle A = \tan A = \frac{\text{side opposite to } \angle A}{\text{side adjacent to angle } \angle A} = \frac{BC}{AB}$$

$$\text{cosecant of } \angle A = \operatorname{cosec} A = \frac{1}{\sin A} = \frac{AC}{BC}$$

$$\text{secant of } \angle A = \sec A = \frac{1}{\cos A} = \frac{AC}{AB}$$

$$\text{cotangent of } \angle A = \cot A = \frac{1}{\tan A} = \frac{AB}{BC}$$

$$\tan A = \frac{\sin A}{\cos A}, \cot A = \frac{\cos A}{\sin A}$$

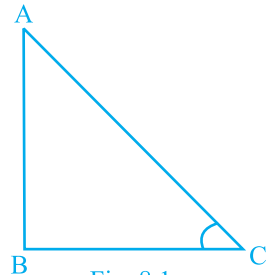

Fig. 8.1

- The values of trigonometric ratios of an angle do not vary with the lengths of the sides of the triangle, if the angle remains the same.
- If one trigonometric ratio of an angle is given, the other trigonometric ratios of the angle can be determined.
- Trigonometric ratios of angles: 0° , 30° , 45° , 60° and 90° .

A	0°	30°	45°	60°	90°
sin A	0	$\frac{1}{2}$	$\frac{1}{\sqrt{2}}$	$\frac{\sqrt{3}}{2}$	1
cos A	1	$\frac{\sqrt{3}}{2}$	$\frac{1}{\sqrt{2}}$	$\frac{1}{2}$	0
tan A	0	$\frac{1}{\sqrt{3}}$	1	$\sqrt{3}$	Not defined
cosec A	Not defined	2	$\sqrt{2}$	$\frac{2}{\sqrt{3}}$	1
sec A	1	$\frac{2}{\sqrt{3}}$	$\sqrt{2}$	2	Not defined
cot A	Not defined	$\sqrt{3}$	1	$\frac{1}{\sqrt{3}}$	0

- The value of sin A or cos A never exceeds 1, whereas the value of sec A or cosec A is always greater than or equal to 1.
- Trigonometric ratios of complementary angles:
 $\sin(90^\circ - A) = \cos A$, $\cos(90^\circ - A) = \sin A$
 $\tan(90^\circ - A) = \cot A$, $\cot(90^\circ - A) = \tan A$
 $\sec(90^\circ - A) = \text{cosec } A$, $\text{cosec}(90^\circ - A) = \sec A$
- Trigonometric identities:
 $\cos^2 A + \sin^2 A = 1$
 $1 + \tan^2 A = \sec^2 A$
 $\cot^2 A + 1 = \text{cosec}^2 A$

- The 'line of sight' is the line from the eye of an observer to the point in the object viewed by the observer.
- The 'angle of elevation' of an object viewed, is the angle formed by the line of sight with the horizontal when it is above the horizontal level.
- The angle of depression of an object viewed, is the angle formed by the line of sight with the horizontal when it is below the horizontal level.
- The height or length of an object or the distance between two distinct objects can be determined with the help of trigonometric ratios.

(B) Multiple Choice Questions

Choose the correct answer from the given four options:

Sample Question 1 : The value of $(\sin 30^\circ + \cos 30^\circ) - (\sin 60^\circ + \cos 60^\circ)$ is

- (A) -1 (B) 0 (C) 1 (D) 2

Solution : Answer (B)

Sample Question 2 : The value of $\frac{\tan 30^\circ}{\cot 60^\circ}$ is

- (A) $\frac{1}{\sqrt{2}}$ (B) $\frac{1}{\sqrt{3}}$ (C) $\sqrt{3}$ (D) 1

Solution : Answer (D)

Sample Question 3 : The value of $(\sin 45^\circ + \cos 45^\circ)$ is

- (A) $\frac{1}{\sqrt{2}}$ (B) $\sqrt{2}$ (C) $\frac{\sqrt{3}}{2}$ (D) 1

Solution : Answer (B)

EXERCISE 8.1

Choose the correct answer from the given four options:

1. If $\cos A = \frac{4}{5}$, then the value of $\tan A$ is

- (A) $\frac{3}{5}$ (B) $\frac{3}{4}$ (C) $\frac{4}{3}$ (D) $\frac{5}{3}$

2. If $\sin A = \frac{1}{2}$, then the value of $\cot A$ is
 (A) $\sqrt{3}$ (B) $\frac{1}{\sqrt{3}}$ (C) $\frac{\sqrt{3}}{2}$ (D) 1
3. The value of the expression $[\operatorname{cosec}(75^\circ + \theta) - \sec(15^\circ - \theta) - \tan(55^\circ + \theta) + \cot(35^\circ - \theta)]$ is
 (A) -1 (B) 0 (C) 1 (D) $\frac{3}{2}$
4. Given that $\sin\theta = \frac{a}{b}$, then $\cos\theta$ is equal to
 (A) $\frac{b}{\sqrt{b^2 - a^2}}$ (B) $\frac{b}{a}$ (C) $\frac{\sqrt{b^2 - a^2}}{b}$ (D) $\frac{a}{\sqrt{b^2 - a^2}}$
5. If $\cos(\alpha + \beta) = 0$, then $\sin(\alpha - \beta)$ can be reduced to
 (A) $\cos\beta$ (B) $\cos 2\beta$ (C) $\sin\alpha$ (D) $\sin 2\alpha$
6. The value of $(\tan 1^\circ \tan 2^\circ \tan 3^\circ \dots \tan 89^\circ)$ is
 (A) 0 (B) 1 (C) 2 (D) $\frac{1}{2}$
7. If $\cos 9\alpha = \sin\alpha$ and $9\alpha < 90^\circ$, then the value of $\tan 5\alpha$ is
 (A) $\frac{1}{\sqrt{3}}$ (B) $\sqrt{3}$ (C) 1 (D) 0
8. If $\triangle ABC$ is right angled at C, then the value of $\cos(A+B)$ is
 (A) 0 (B) 1 (C) $\frac{1}{2}$ (D) $\frac{\sqrt{3}}{2}$
9. If $\sin A + \sin^2 A = 1$, then the value of the expression $(\cos^2 A + \cos^4 A)$ is
 (A) 1 (B) $\frac{1}{2}$ (C) 2 (D) 3
10. Given that $\sin\alpha = \frac{1}{2}$ and $\cos\beta = \frac{1}{2}$, then the value of $(\alpha + \beta)$ is
 (A) 0° (B) 30° (C) 60° (D) 90°

11. The value of the expression $\left[\frac{\sin^2 22^\circ + \sin^2 68^\circ}{\cos^2 22^\circ + \cos^2 68^\circ} + \sin^2 63^\circ + \cos 63^\circ \sin 27^\circ \right]$ is

- (A) 3 (B) 2 (C) 1 (D) 0

12. If $4 \tan \theta = 3$, then $\left(\frac{4 \sin \theta - \cos \theta}{4 \sin \theta + \cos \theta} \right)$ is equal to

- (A) $\frac{2}{3}$ (B) $\frac{1}{3}$ (C) $\frac{1}{2}$ (D) $\frac{3}{4}$

13. If $\sin \theta - \cos \theta = 0$, then the value of $(\sin^4 \theta + \cos^4 \theta)$ is

- (A) 1 (B) $\frac{3}{4}$ (C) $\frac{1}{2}$ (D) $\frac{1}{4}$

14. $\sin(45^\circ + \theta) - \cos(45^\circ - \theta)$ is equal to

- (A) $2 \cos \theta$ (B) 0 (C) $2 \sin \theta$ (D) 1

15. A pole 6 m high casts a shadow $2\sqrt{3}$ m long on the ground, then the Sun's elevation is

- (A) 60° (B) 45° (C) 30° (D) 90°

(C) Short Answer Questions with Reasoning

Write 'True' or 'False' and justify your answer.

Sample Question 1 : The value of $\sin \theta + \cos \theta$ is always greater than 1.

Solution : False.

The value of $(\sin \theta + \cos \theta)$ for $\theta = 0^\circ$ is 1.

Sample Question 2 : The value of $\tan \theta$ ($\theta < 90^\circ$) increases as θ increases.

Solution : True.

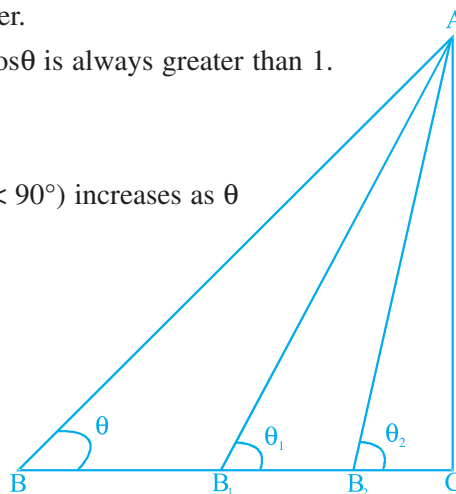

Fig. 8.2

In Fig. 8.2, B is moved closer to C along BC. It is observed that

- (i) θ increases (as $\theta_1 > \theta$, $\theta_2 > \theta_1$, ...)
- (ii) BC decreases ($B_1C < BC$, $B_2C < B_1C$, ...)

Thus the perpendicular AC remains fixed and the base BC decreases. Hence $\tan\theta$ increases as θ increases.

Sample Question 3 : $\tan\theta$ increases faster than $\sin\theta$ as θ increases.

Solution : True

We know that $\sin\theta$ increases as θ increases but $\cos\theta$ decreases as θ increases.

$$\text{We have } \tan\theta = \frac{\sin\theta}{\cos\theta}$$

Now as θ increases, $\sin\theta$ increases but $\cos\theta$ decreases. Therefore, in case of $\tan\theta$, the numerator increases and the denominator decreases. But in case of $\sin\theta$ which can be

seen as $\frac{\sin\theta}{1}$, only the numerator increases but the denominator remains fixed at 1.

Hence $\tan\theta$ increases faster than $\sin\theta$ as θ increases.

Sample Question 4 : The value of $\sin\theta$ is $a + \frac{1}{a}$, where 'a' is a positive number.

Solution : False.

We know that $\sqrt{a} - \frac{1}{\sqrt{a}} \geq 0$ or $a + \frac{1}{a} \geq 2$, but $\sin\theta$ is not greater than 1.

Alternatively, there exists the following three possibilities :

$$\text{Case 1. If } a < 1, \text{ then } a + \frac{1}{a} > 1$$

$$\text{Case 2. If } a = 1, \text{ then } a + \frac{1}{a} > 1$$

$$\text{Case 3. If } a > 1, \text{ then } a + \frac{1}{a} > 1$$

However, $\sin\theta$ cannot be greater than 1.

EXERCISE 8.2

Write 'True' or 'False' and justify your answer in each of the following:

- $\frac{\tan 47^\circ}{\cot 43^\circ} = 1$
- The value of the expression $(\cos^2 23^\circ - \sin^2 67^\circ)$ is positive.
- The value of the expression $(\sin 80^\circ - \cos 80^\circ)$ is negative.
- $\sqrt{(1 - \cos^2 \theta) \sec^2 \theta} = \tan \theta$
- If $\cos A + \cos^2 A = 1$, then $\sin^2 A + \sin^4 A = 1$.
- $(\tan \theta + 2)(2 \tan \theta + 1) = 5 \tan \theta + \sec^2 \theta$.
- If the length of the shadow of a tower is increasing, then the angle of elevation of the sun is also increasing.
- If a man standing on a platform 3 metres above the surface of a lake observes a cloud and its reflection in the lake, then the angle of elevation of the cloud is equal to the angle of depression of its reflection.
- The value of $2 \sin \theta$ can be $a + \frac{1}{a}$, where a is a positive number, and $a \neq 1$.
- $\cos \theta = \frac{a^2 + b^2}{2ab}$, where a and b are two distinct numbers such that $ab > 0$.
- The angle of elevation of the top of a tower is 30° . If the height of the tower is doubled, then the angle of elevation of its top will also be doubled.
- If the height of a tower and the distance of the point of observation from its foot, both, are increased by 10%, then the angle of elevation of its top remains unchanged.

(D) Short Answer Questions

Sample Question 1 : Prove that $\sin^6 \theta + \cos^6 \theta + 3 \sin^2 \theta \cos^2 \theta = 1$

Solution : We know that $\sin^2 \theta + \cos^2 \theta = 1$

Therefore, $(\sin^2 \theta + \cos^2 \theta)^3 = 1$

or, $(\sin^2 \theta)^3 + (\cos^2 \theta)^3 + 3 \sin^2 \theta \cos^2 \theta (\sin^2 \theta + \cos^2 \theta) = 1$

or, $\sin^6 \theta + \cos^6 \theta + 3 \sin^2 \theta \cos^2 \theta = 1$

Sample Question 2 : Prove that $(\sin^4 \theta - \cos^4 \theta + 1) \operatorname{cosec}^2 \theta = 2$

Solution :

$$\begin{aligned}
\text{L.H.S.} &= (\sin^4\theta - \cos^4\theta + 1) \operatorname{cosec}^2\theta \\
&= [(\sin^2\theta - \cos^2\theta)(\sin^2\theta + \cos^2\theta) + 1] \operatorname{cosec}^2\theta \\
&= (\sin^2\theta - \cos^2\theta + 1) \operatorname{cosec}^2\theta \\
&\qquad\qquad\qquad [\text{Because } \sin^2\theta + \cos^2\theta = 1] \\
&= 2\sin^2\theta \operatorname{cosec}^2\theta \qquad [\text{Because } 1 - \cos^2\theta = \sin^2\theta] \\
&= 2 = \text{RHS}
\end{aligned}$$

Sample Question 3 : Given that $\alpha + \beta = 90^\circ$, show that

$$\sqrt{\cos \alpha \operatorname{cosec} \beta - \cos \alpha \sin \beta} = \sin \alpha$$

Solution :

$$\begin{aligned}
\sqrt{\cos \alpha \operatorname{cosec} \beta - \cos \alpha \sin \beta} &= \sqrt{\cos \alpha \operatorname{cosec} (90^\circ - \alpha) - \cos \alpha \sin (90^\circ - \alpha)} \\
&\qquad\qquad\qquad [\text{Given } \alpha + \beta = 90^\circ] \\
&= \sqrt{\cos \alpha \sec \alpha - \cos \alpha \cos \alpha} \\
&= \sqrt{1 - \cos^2 \alpha} \\
&= \sin \alpha
\end{aligned}$$

Sample Question 4 : If $\sin \theta + \cos \theta = \sqrt{3}$, then prove that $\tan \theta + \cot \theta = 1$

Solution :

$$\begin{aligned}
&\sin \theta + \cos \theta = \sqrt{3} \qquad\qquad\qquad (\text{Given}) \\
\text{or} &\quad (\sin \theta + \cos \theta)^2 = 3 \\
\text{or} &\quad \sin^2 \theta + \cos^2 \theta + 2\sin \theta \cos \theta = 3 \\
&\quad 2\sin \theta \cos \theta = 2 \qquad\qquad\qquad [\sin^2 \theta + \cos^2 \theta = 1] \\
\text{or} &\quad \sin \theta \cos \theta = 1 = \sin^2 \theta + \cos^2 \theta \\
\text{or} &\quad 1 = \frac{\sin^2 \theta + \cos^2 \theta}{\sin \theta \cos \theta}
\end{aligned}$$

Therefore, $\tan \theta + \cot \theta = 1$

EXERCISE 8.3

Prove the following (from Q.1 to Q.7):

$$1. \quad \frac{\sin \theta}{1 + \cos \theta} + \frac{1 + \cos \theta}{\sin \theta} = 2 \operatorname{cosec} \theta$$

$$2. \quad \frac{\tan A}{1 + \sec A} - \frac{\tan A}{1 - \sec A} = 2 \operatorname{cosec} A$$

$$3. \quad \text{If } \tan A = \frac{3}{4}, \text{ then } \sin A \cos A = \frac{12}{25}$$

$$4. \quad (\sin \alpha + \cos \alpha) (\tan \alpha + \cot \alpha) = \sec \alpha + \operatorname{cosec} \alpha$$

$$5. \quad (\sqrt{3} + 1) (3 - \cot 30^\circ) = \tan^3 60^\circ - 2 \sin 60^\circ$$

$$6. \quad 1 + \frac{\cot^2 \alpha}{1 + \operatorname{cosec} \alpha} = \operatorname{cosec} \alpha$$

$$7. \quad \tan \theta + \tan (90^\circ - \theta) = \sec \theta \sec (90^\circ - \theta)$$

8. Find the angle of elevation of the sun when the shadow of a pole h metres high is $\sqrt{3} h$ metres long.

9. If $\sqrt{3} \tan \theta = 1$, then find the value of $\sin^2 \theta - \cos^2 \theta$.

10. A ladder 15 metres long just reaches the top of a vertical wall. If the ladder makes an angle of 60° with the wall, find the height of the wall.

11. Simplify $(1 + \tan^2 \theta) (1 - \sin \theta) (1 + \sin \theta)$

12. If $2 \sin^2 \theta - \cos^2 \theta = 2$, then find the value of θ .

13. Show that $\frac{\cos^2 (45^\circ + \theta) + \cos^2 (45^\circ - \theta)}{\tan (60^\circ + \theta) \tan (30^\circ - \theta)} = 1$

14. An observer 1.5 metres tall is 20.5 metres away from a tower 22 metres high. Determine the angle of elevation of the top of the tower from the eye of the observer.

15. Show that $\tan^4 \theta + \tan^2 \theta = \sec^4 \theta - \sec^2 \theta$.

(E) Long Answer Questions

Sample Question 1 : A spherical balloon of radius r subtends an angle θ at the eye of an observer. If the angle of elevation of its centre is ϕ , find the height of the centre of the balloon.

Solution : In Fig. 8.3, O is the centre of balloon, whose radius $OP = r$ and $\angle PAQ = \theta$. Also, $\angle OAB = \phi$.

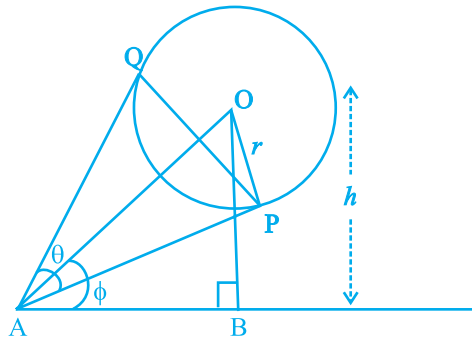

Fig. 8.3

Let the height of the centre of the balloon be h . Thus $OB = h$.

$$\text{Now, from } \triangle OAP, \sin \frac{\theta}{2} = \frac{r}{d}, \text{ where } OA = d \quad (1)$$

$$\text{Also from } \triangle OAB, \sin \phi = \frac{h}{d}. \quad (2)$$

$$\text{From (1) and (2), we get } \frac{\sin \phi}{\sin \frac{\theta}{2}} = \frac{\frac{h}{d}}{\frac{r}{d}} = \frac{h}{r}$$

$$\text{or } h = r \sin \phi \operatorname{cosec} \frac{\theta}{2}.$$

Sample Question 2 : From a balloon vertically above a straight road, the angles of depression of two cars at an instant are found to be 45° and 60° . If the cars are 100 m apart, find the height of the balloon.

Solution : Let the height of the balloon at P be h meters (see Fig. 8.4). Let A and B be the two cars. Thus $AB = 100$ m. From ΔPAQ , $AQ = PQ = h$

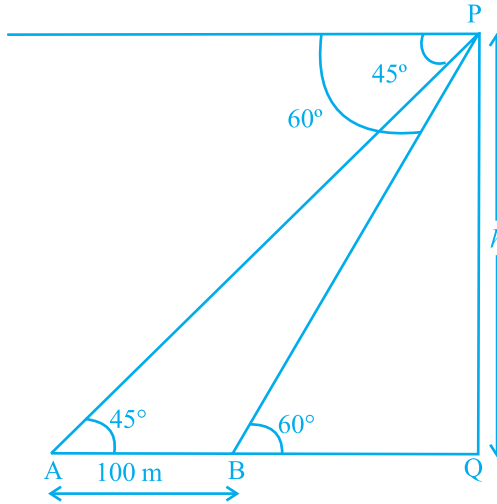

Fig. 8.4

Now from ΔPBQ , $\frac{PQ}{BQ} = \tan 60^\circ = \sqrt{3}$ or $\frac{h}{h-100} = \sqrt{3}$

or $h = \sqrt{3}(h-100)$

Therefore, $h = \frac{100\sqrt{3}}{\sqrt{3}-1} = 50(3 + \sqrt{3})$

i.e., the height of the balloon is $50(3 + \sqrt{3})$ m.

Sample Question 3 : The angle of elevation of a cloud from a point h metres above the surface of a lake is θ and the angle of depression of its reflection in the lake is ϕ .

Prove that the height of the cloud above the lake is $h \left(\frac{\tan \phi + \tan \theta}{\tan \phi - \tan \theta} \right)$.

Solution : Let P be the cloud and Q be its reflection in the lake (see Fig. 8.5). Let A be the point of observation such that $AB = h$.

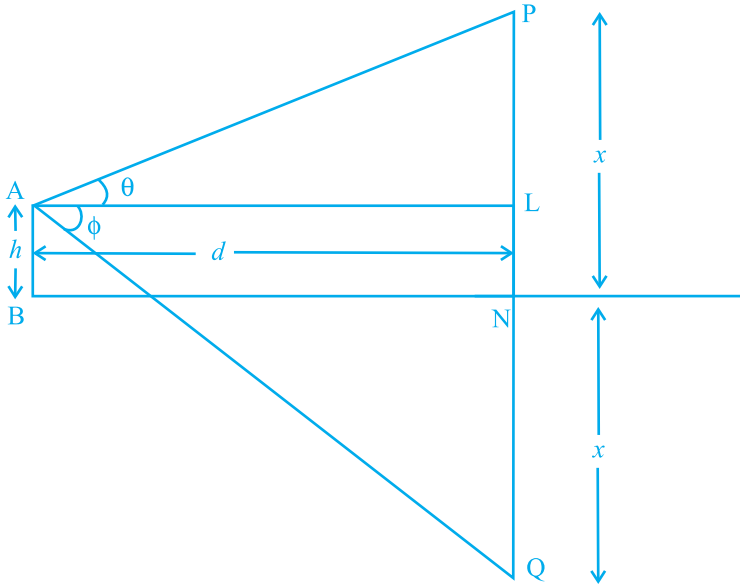

Fig. 8.5

Let the height of the cloud above the lake be x . Let $AL = d$.

$$\text{Now from } \triangle PAL, \frac{x-h}{d} = \tan \theta \quad (1)$$

$$\text{From } \triangle QAL, \frac{x+h}{d} = \tan \phi \quad (2)$$

From (1) and (2), we get

$$\frac{x+h}{x-h} = \frac{\tan \phi}{\tan \theta}$$

$$\text{or } \frac{2x}{2h} = \frac{\tan \phi + \tan \theta}{\tan \phi - \tan \theta}$$

$$\text{Therefore, } x = h \left(\frac{\tan \phi + \tan \theta}{\tan \phi - \tan \theta} \right).$$

EXERCISE 8.4

1. If $\operatorname{cosec}\theta + \cot\theta = p$, then prove that $\cos\theta = \frac{p^2 - 1}{p^2 + 1}$.
2. Prove that $\sqrt{\sec^2\theta + \operatorname{cosec}^2\theta} = \tan\theta + \cot\theta$
3. The angle of elevation of the top of a tower from certain point is 30° . If the observer moves 20 metres towards the tower, the angle of elevation of the top increases by 15° . Find the height of the tower.
4. If $1 + \sin^2\theta = 3\sin\theta \cos\theta$, then prove that $\tan\theta = 1$ or $\frac{1}{2}$.
5. Given that $\sin\theta + 2\cos\theta = 1$, then prove that $2\sin\theta - \cos\theta = 2$.
6. The angle of elevation of the top of a tower from two points distant s and t from its foot are complementary. Prove that the height of the tower is \sqrt{st} .
7. The shadow of a tower standing on a level plane is found to be 50 m longer when Sun's elevation is 30° than when it is 60° . Find the height of the tower.
8. A vertical tower stands on a horizontal plane and is surmounted by a vertical flag staff of height h . At a point on the plane, the angles of elevation of the bottom and the top of the flag staff are α and β , respectively. Prove that the height of the tower is $\left(\frac{h \tan \alpha}{\tan \beta - \tan \alpha}\right)$.
9. If $\tan\theta + \sec\theta = l$, then prove that $\sec\theta = \frac{l^2 + 1}{2l}$.
10. If $\sin\theta + \cos\theta = p$ and $\sec\theta + \operatorname{cosec}\theta = q$, then prove that $q(p^2 - 1) = 2p$.
11. If $a \sin\theta + b \cos\theta = c$, then prove that $a \cos\theta - b \sin\theta = \sqrt{a^2 + b^2 - c^2}$.
12. Prove that $\frac{1 + \sec\theta - \tan\theta}{1 + \sec\theta + \tan\theta} = \frac{1 - \sin\theta}{\cos\theta}$
13. The angle of elevation of the top of a tower 30 m high from the foot of another tower in the same plane is 60° and the angle of elevation of the top of the second tower from the foot of the first tower is 30° . Find the distance between the two towers and also the height of the other tower.

- 14.** From the top of a tower h m high, the angles of depression of two objects, which are in line with the foot of the tower are α and β ($\beta > \alpha$). Find the distance between the two objects.
- 15.** A ladder rests against a vertical wall at an inclination α to the horizontal. Its foot is pulled away from the wall through a distance p so that its upper end slides a distance q down the wall and then the ladder makes an angle β to the horizontal.

Show that
$$\frac{p}{q} = \frac{\cos\beta - \cos\alpha}{\sin\alpha - \sin\beta} .$$

- 16.** The angle of elevation of the top of a vertical tower from a point on the ground is 60° . From another point 10 m vertically above the first, its angle of elevation is 45° . Find the height of the tower.
- 17.** A window of a house is h metres above the ground. From the window, the angles of elevation and depression of the top and the bottom of another house situated on the opposite side of the lane are found to be α and β , respectively. Prove that the height of the other house is $h (1 + \tan \alpha \cot \beta)$ metres.
- 18.** The lower window of a house is at a height of 2 m above the ground and its upper window is 4 m vertically above the lower window. At certain instant the angles of elevation of a balloon from these windows are observed to be 60° and 30° , respectively. Find the height of the balloon above the ground.

CIRCLES

(A) Main Concepts and Results

- The meaning of a tangent and its point of contact on a circle.
- Tangent is perpendicular to the radius through the point of contact.
- Only two tangents can be drawn to a circle from an external point.
- Lengths of tangents from an external point to a circle are equal.

(B) Multiple Choice Questions

Choose the correct answer from the given four options:

Sample Question 1 : If angle between two radii of a circle is 130° , the angle between the tangents at the ends of the radii is :

- (A) 90° (B) 50° (C) 70° (D) 40°

Solution : Answer (B)

Sample Question 2 : In Fig. 9.1, the pair of tangents AP and AQ drawn from an external point A to a circle with centre O are perpendicular to each other and length of each tangent is 5 cm. Then the radius of the circle is

- (A) 10 cm (B) 7.5 cm
(C) 5 cm (D) 2.5 cm

Solution: Answer (C)

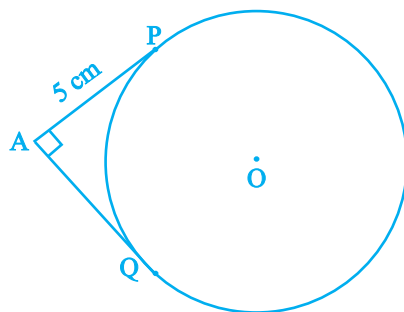

Fig. 9.1

Sample Question 3: In Fig. 9.2, PQ is a chord of a circle and PT is the tangent at P such that $\angle QPT = 60^\circ$. Then $\angle PRQ$ is equal to

- (A) 135° (B) 150°
 (C) 120° (D) 110°

Solution : Answer (C)

[**Hint :** $\angle OPQ = \angle OQP = 30^\circ$, i.e., $\angle POQ = 120^\circ$. Also, $\angle PRQ = \frac{1}{2}$ reflex $\angle POQ$]

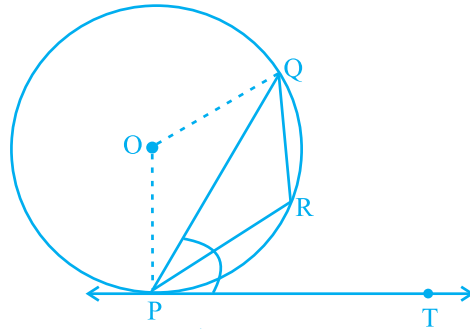

Fig. 9.2

EXERCISE 9.1

Choose the correct answer from the given four options:

1. If radii of two concentric circles are 4 cm and 5 cm, then the length of each chord of one circle which is tangent to the other circle is

- (A) 3 cm (B) 6 cm
 (C) 9 cm (D) 1 cm

2. In Fig. 9.3, if $\angle AOB = 125^\circ$, then $\angle COD$ is equal to

- (A) 62.5° (B) 45°
 (C) 35° (D) 55°

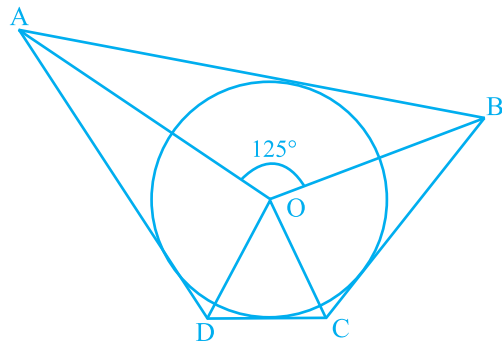

Fig. 9.3

3. In Fig. 9.4, AB is a chord of the circle and AOC is its diameter such that $\angle ACB = 50^\circ$. If AT is the tangent to the circle at the point A, then $\angle BAT$ is equal to

- (A) 65° (B) 60°
 (C) 50° (D) 40°

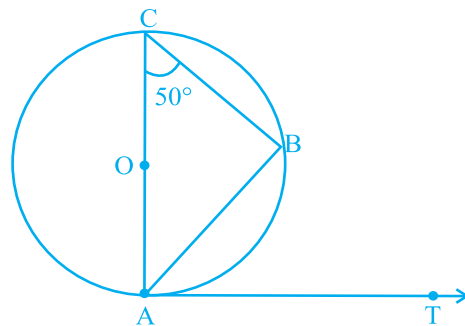

Fig. 9.4

4. From a point P which is at a distance of 13 cm from the centre O of a circle of radius 5 cm, the pair of tangents PQ and PR to the circle are drawn. Then the area of the quadrilateral PQOR is
 (A) 60 cm^2 (B) 65 cm^2 (C) 30 cm^2 (D) 32.5 cm^2
5. At one end A of a diameter AB of a circle of radius 5 cm, tangent XAY is drawn to the circle. The length of the chord CD parallel to XY and at a distance 8 cm from A is
 (A) 4 cm (B) 5 cm
 (C) 6 cm (D) 8 cm

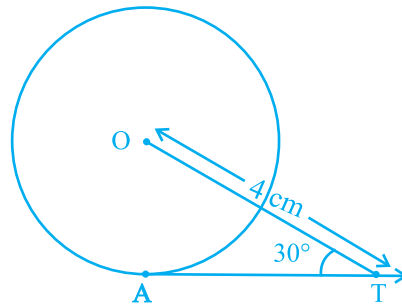

Fig. 9.5

6. In Fig. 9.5, AT is a tangent to the circle with centre O such that $OT = 4 \text{ cm}$ and $\angle OTA = 30^\circ$. Then AT is equal to
 (A) 4 cm (B) 2 cm
 (C) $2\sqrt{3} \text{ cm}$ (D) $4\sqrt{3} \text{ cm}$

7. In Fig. 9.6, if O is the centre of a circle, PQ is a chord and the tangent PR at P makes an angle of 50° with PQ, then $\angle POQ$ is equal to
 (A) 100° (B) 80°
 (C) 90° (D) 75°

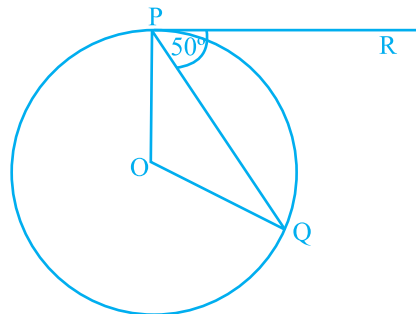

Fig. 9.6

8. In Fig. 9.7, if PA and PB are tangents to the circle with centre O such that $\angle APB = 50^\circ$, then $\angle OAB$ is equal to
 (A) 25° (B) 30°
 (C) 40° (D) 50°

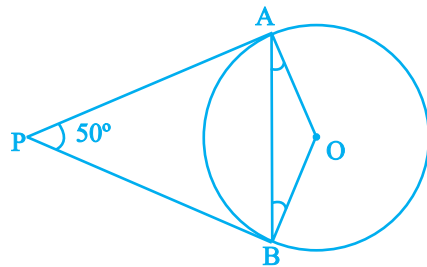

Fig. 9.7

9. If two tangents inclined at an angle 60° are drawn to a circle of radius 3 cm, then length of each tangent is equal to

- (A) $\frac{3}{2}\sqrt{3}$ cm (B) 6 cm
 (C) 3 cm (D) $3\sqrt{3}$ cm

10. In Fig. 9.8, if PQR is the tangent to a circle at Q whose centre is O, AB is a chord parallel to PR and $\angle BQR = 70^\circ$, then $\angle AQB$ is equal to

- (A) 20° (B) 40°
 (C) 35° (D) 45°

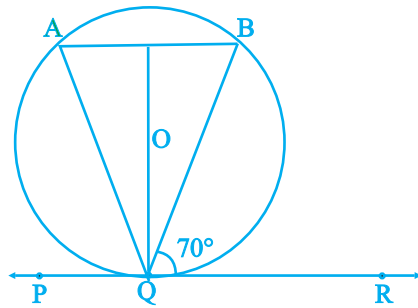

Fig. 9.8

(C) Short Answer Questions with Reasoning

Write 'True' or 'False' and give reasons for your answer.

Sample Question 1 : In Fig. 9.9, BOA is a diameter of a circle and the tangent at a point P meets BA extended at T. If $\angle PBO = 30^\circ$, then $\angle PTA$ is equal to 30° .

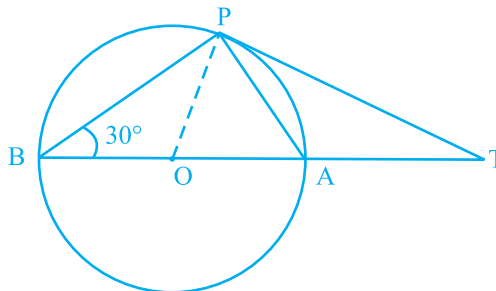
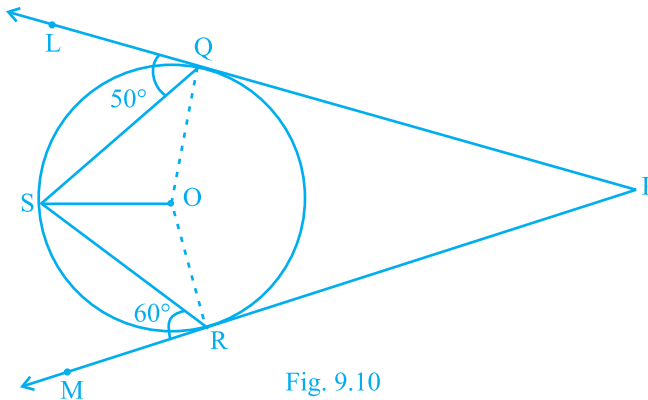

Fig. 9.9

Solution : True. As $\angle BPA = 90^\circ$, $\angle PAB = \angle OPA = 60^\circ$. Also, $OP \perp PT$. Therefore, $\angle APT = 30^\circ$ and $\angle PTA = 60^\circ - 30^\circ = 30^\circ$.

Sample Question 2 : In Fig. 9.10, PQL and PRM are tangents to the circle with centre O at the points Q and R, respectively and S is a point on the circle such that $\angle SQL = 50^\circ$ and $\angle SRM = 60^\circ$. Then $\angle QSR$ is equal to 40° .



Solution : False. Here $\angle OSQ = \angle OQS = 90^\circ - 50^\circ = 40^\circ$ and $\angle RSO = \angle SRO = 90^\circ - 60^\circ = 30^\circ$. Therefore, $\angle QSR = 40^\circ + 30^\circ = 70^\circ$.

EXERCISE 9.2

Write 'True' or 'False' and justify your answer in each of the following :

1. If a chord AB subtends an angle of 60° at the centre of a circle, then angle between the tangents at A and B is also 60° .
2. The length of tangent from an external point on a circle is always greater than the radius of the circle.
3. The length of tangent from an external point P on a circle with centre O is always less than OP.
4. The angle between two tangents to a circle may be 0° .
5. If angle between two tangents drawn from a point P to a circle of radius a and centre O is 90° , then $OP = a\sqrt{2}$.
6. If angle between two tangents drawn from a point P to a circle of radius a and centre O is 60° , then $OP = a\sqrt{3}$.
7. The tangent to the circumcircle of an isosceles triangle ABC at A, in which $AB = AC$, is parallel to BC.

8. If a number of circles touch a given line segment PQ at a point A, then their centres lie on the perpendicular bisector of PQ.
9. If a number of circles pass through the end points P and Q of a line segment PQ, then their centres lie on the perpendicular bisector of PQ.
10. AB is a diameter of a circle and AC is its chord such that $\angle BAC = 30^\circ$. If the tangent at C intersects AB extended at D, then $BC = BD$.

(D) Short Answer Questions

Sample Question 1 : If d_1, d_2 ($d_2 > d_1$) be the diameters of two concentric circles and c be the length of a chord of a circle which is tangent to the other circle, prove that $d_2^2 = c^2 + d_1^2$.

Solution : Let AB be a chord of a circle which touches the other circle at C. Then $\triangle OCB$ is right triangle (see Fig.9.11). By Pythagoras theorem $OC^2 + CB^2 = OB^2$.

$$\text{i.e., } \frac{1}{2}d_1^2 + \frac{1}{2}c^2 = \frac{1}{2}d_2^2$$

(As C bisects AB)

Therefore, $d_2^2 = c^2 + d_1^2$.

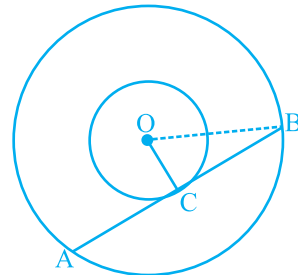

Fig. 9.11

Sample Question 2 : If a, b, c are the sides of a right triangle where c is the hypotenuse, prove that the radius r of the circle which touches the sides of the triangle is given by

$$r = \frac{a + b - c}{2}.$$

Solution : Let the circle touches the sides BC, CA, AB of the right triangle ABC at D, E and F respectively, where $BC = a$, $CA = b$ and $AB = c$ (see Fig. 9.12). Then $AE = AF$ and $BD = BF$. Also $CE = CD = r$.

$$\text{i.e., } b - r = AF, \quad a - r = BF$$

$$\text{or } AB = c = AF + BF = b - r + a - r$$

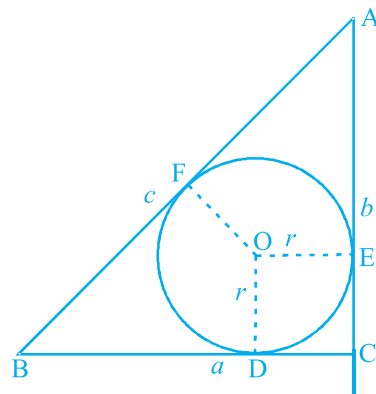

Fig. 9.12

$$\text{This gives } r = \frac{a + b - c}{2}$$

EXERCISE 9.3

1. Out of the two concentric circles, the radius of the outer circle is 5 cm and the chord AC of length 8 cm is a tangent to the inner circle. Find the radius of the inner circle.
2. Two tangents PQ and PR are drawn from an external point to a circle with centre O. Prove that QORP is a cyclic quadrilateral.
3. If from an external point B of a circle with centre O, two tangents BC and BD are drawn such that $\angle DBC = 120^\circ$, prove that $BC + BD = BO$, i.e., $BO = 2BC$.
4. Prove that the centre of a circle touching two intersecting lines lies on the angle bisector of the lines.

5. In Fig. 9.13, AB and CD are common tangents to two circles of unequal radii. Prove that $AB = CD$.

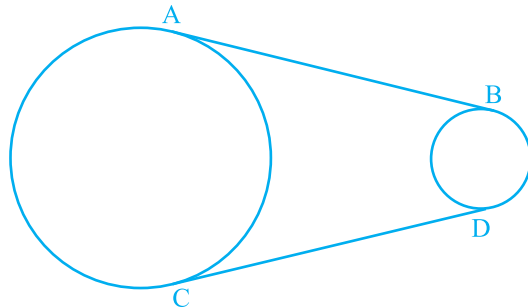

Fig. 9.13

6. In Question 5 above, if radii of the two circles are equal, prove that $AB = CD$.

7. In Fig. 9.14, common tangents AB and CD to two circles intersect at E. Prove that $AB = CD$.

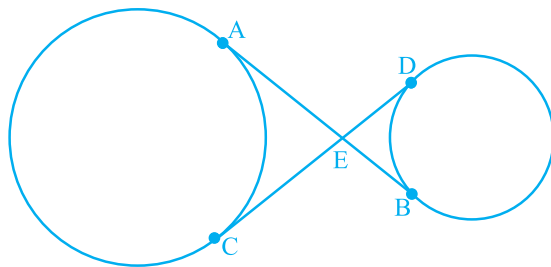

Fig. 9.14

8. A chord PQ of a circle is parallel to the tangent drawn at a point R of the circle. Prove that R bisects the arc PRQ.

9. Prove that the tangents drawn at the ends of a chord of a circle make equal angles with the chord.
10. Prove that a diameter AB of a circle bisects all those chords which are parallel to the tangent at the point A.

(E) Long Answer Questions

Sample Question 1 : In Fig. 9.15, from an external point P, a tangent PT and a line segment PAB is drawn to a circle with centre O. ON is perpendicular on the chord AB. Prove that :

- (i) $PA \cdot PB = PN^2 - AN^2$
- (ii) $PN^2 - AN^2 = OP^2 - OT^2$
- (iii) $PA \cdot PB = PT^2$

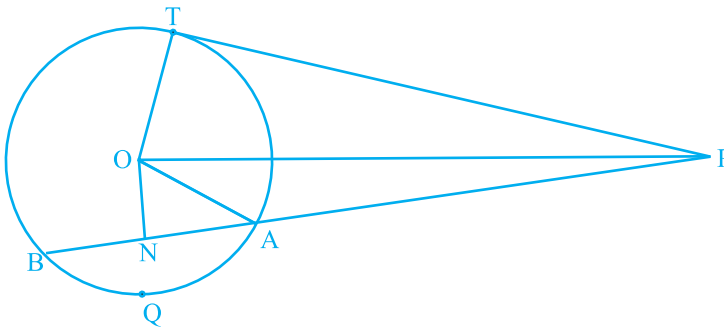

Fig. 9.15

Solution :

- (i) $PA \cdot PB = (PN - AN)(PN + AN)$
 $= (PN - AN)(PN + AN)$ (As $AN = BN$)
 $= PN^2 - AN^2$
- (ii) $PN^2 - AN^2 = (OP^2 - ON^2) - AN^2$ (As $ON \perp PN$)
 $= OP^2 - (ON^2 + AN^2)$
 $= OP^2 - OA^2$ (As $ON \perp AN$)
 $= OP^2 - OT^2$ (As $OA = OT$)

(iii)

From (i) and (ii)

$$PA.PB = OP^2 - OT^2$$

$$= PT^2$$

(As $\angle OTP = 90^\circ$)

Sample Question 2 : If a circle touches the side BC of a triangle ABC at P and extended sides AB and AC at Q and R, respectively, prove that $AQ = \frac{1}{2}(BC + CA + AB)$

Solution : See Fig. 9.16.

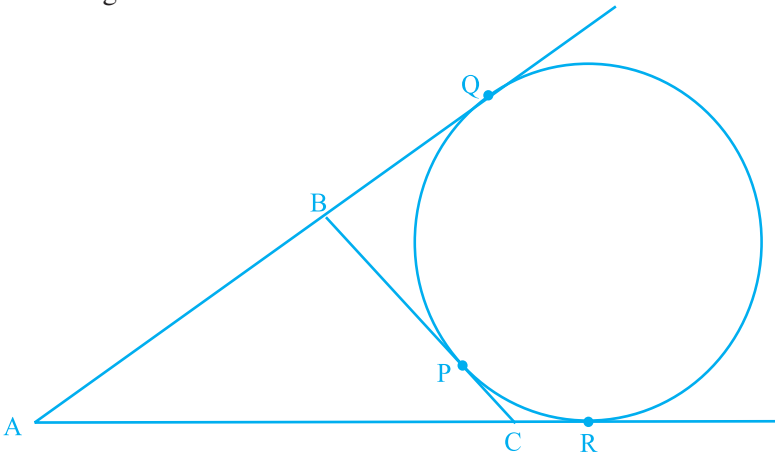

Fig. 9.16

By Theorem 10.2 of the textbook,

$$BQ = BP$$

$$CP = CR, \text{ and}$$

$$AQ = AR$$

Now,

$$2AQ = AQ + AR$$

$$= (AB + BQ) + (AC + CR)$$

$$= AB + BP + AC + CP$$

$$= (BP + CP) + AC + AB$$

$$= BC + CA + AB$$

i.e., $AQ = \frac{1}{2}(BC + CA + AB).$

EXERCISE 9.4

1. If a hexagon $ABCDEF$ circumscribe a circle, prove that $AB + CD + EF = BC + DE + FA$.
2. Let s denote the semi-perimeter of a triangle ABC in which $BC = a$, $CA = b$, $AB = c$. If a circle touches the sides BC , CA , AB at D , E , F , respectively, prove that $BD = s - b$.
3. From an external point P , two tangents, PA and PB are drawn to a circle with centre O . At one point E on the circle tangent is drawn which intersects PA and PB at C and D , respectively. If $PA = 10$ cm, find the the perimeter of the triangle PCD .
4. If AB is a chord of a circle with centre O , AOC is a diameter and AT is the tangent at A as shown in Fig. 9.17. Prove that $\angle BAT = \angle ACB$

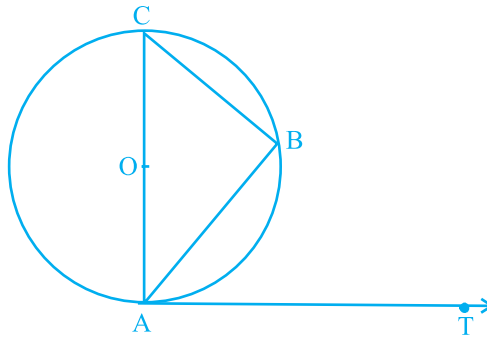

Fig. 9.17

5. Two circles with centres O and O' of radii 3 cm and 4 cm, respectively intersect at two points P and Q such that OP and $O'P$ are tangents to the two circles. Find the length of the common chord PQ .
6. In a right triangle ABC in which $\angle B = 90^\circ$, a circle is drawn with AB as diameter intersecting the hypotenuse AC at P . Prove that the tangent to the circle at P bisects BC .
7. In Fig. 9.18, tangents PQ and PR are drawn to a circle such that $\angle RPQ = 30^\circ$. A chord RS is drawn parallel to the tangent PQ . Find the $\angle RQS$.

[**Hint:** Draw a line through Q and perpendicular to QP.]

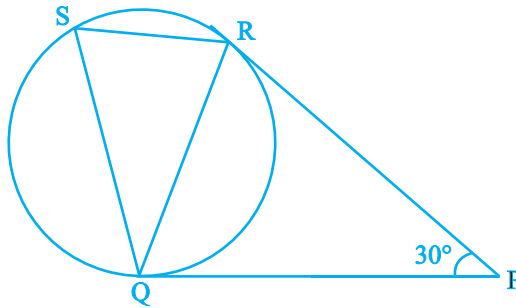

Fig. 9.18

8. AB is a diameter and AC is a chord of a circle with centre O such that $\angle BAC = 30^\circ$. The tangent at C intersects extended AB at a point D. Prove that $BC = BD$.
9. Prove that the tangent drawn at the mid-point of an arc of a circle is parallel to the chord joining the end points of the arc.
10. In Fig. 9.19, the common tangent, AB and CD to two circles with centres O and O' intersect at E. Prove that the points O, E, O' are collinear.

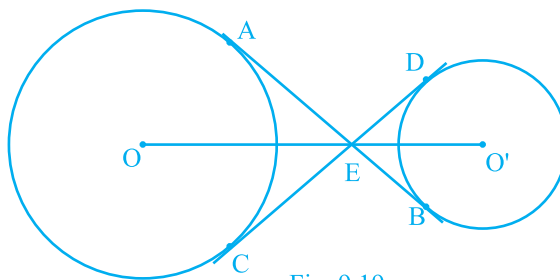

Fig. 9.19

11. In Fig. 9.20, O is the centre of a circle of radius 5 cm, T is a point such that $OT = 13$ cm and OT intersects the circle at E. If AB is the tangent to the circle at E, find the length of AB.

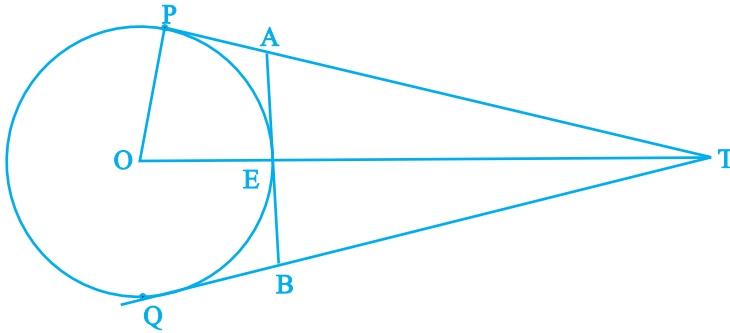

Fig. 9.20

12. The tangent at a point C of a circle and a diameter AB when extended intersect at P. If $\angle PCA = 110^\circ$, find $\angle CBA$ [see Fig. 9.21].

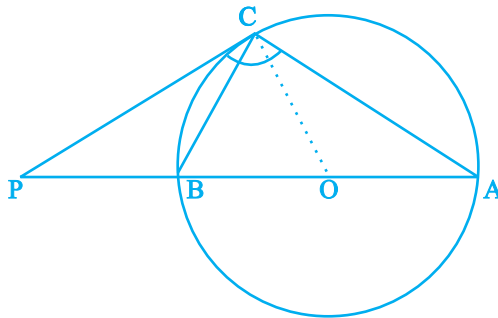

Fig. 9.21

[**Hint:** Join C with centre O.]

13. If an isosceles triangle ABC, in which $AB = AC = 6$ cm, is inscribed in a circle of radius 9 cm, find the area of the triangle.
14. A is a point at a distance 13 cm from the centre O of a circle of radius 5 cm. AP and AQ are the tangents to the circle at P and Q. If a tangent BC is drawn at a point R lying on the minor arc PQ to intersect AP at B and AQ at C, find the perimeter of the $\triangle ABC$.

CONSTRUCTIONS

(A) Main Concepts and Results

- Division of a line segment internally in a given ratio.
- Construction of a triangle similar to a given triangle as per given scale factor which may be less than 1 or greater than 1.
- Construction of the pair of tangents from an external point to a circle.

(B) Multiple Choice Questions

Choose the correct answer from the given four options:

Sample Question 1 : To divide a line segment AB in the ratio $p : q$ (p, q are positive integers), draw a ray AX so that $\angle BAX$ is an acute angle and then mark points on ray AX at equal distances such that the minimum number of these points is

- (A) greater of p and q (B) $p + q$
(C) $p + q - 1$ (D) pq

Solution : Answer (B)

Sample Question 2 : To draw a pair of tangents to a circle which are inclined to each other at an angle of 35° , it is required to draw tangents at the end points of those two radii of the circle, the angle between which is

- (A) 105° (B) 70° (C) 140° (D) 145°

Solution : Answer (D)

EXERCISE 10.1

Choose the correct answer from the given four options:

1. To divide a line segment AB in the ratio 5:7, first a ray AX is drawn so that $\angle BAX$ is an acute angle and then at equal distances points are marked on the ray AX such that the minimum number of these points is
 (A) 8 (B) 10 (C) 11 (D) 12

2. To divide a line segment AB in the ratio 4:7, a ray AX is drawn first such that $\angle BAX$ is an acute angle and then points A_1, A_2, A_3, \dots are located at equal distances on the ray AX and the point B is joined to
 (A) A_{12} (B) A_{11} (C) A_{10} (D) A_9

3. To divide a line segment AB in the ratio 5 : 6, draw a ray AX such that $\angle BAX$ is an acute angle, then draw a ray BY parallel to AX and the points A_1, A_2, A_3, \dots and B_1, B_2, B_3, \dots are located at equal distances on ray AX and BY, respectively. Then the points joined are
 (A) A_5 and B_6 (B) A_6 and B_5 (C) A_4 and B_5 (D) A_5 and B_4

4. To construct a triangle similar to a given $\triangle ABC$ with its sides $\frac{3}{7}$ of the corresponding sides of $\triangle ABC$, first draw a ray BX such that $\angle CBX$ is an acute angle and X lies on the opposite side of A with respect to BC. Then locate points B_1, B_2, B_3, \dots on BX at equal distances and next step is to join
 (A) B_{10} to C (B) B_3 to C (C) B_7 to C (D) B_4 to C

5. To construct a triangle similar to a given $\triangle ABC$ with its sides $\frac{8}{5}$ of the corresponding sides of $\triangle ABC$ draw a ray BX such that $\angle CBX$ is an acute angle and X is on the opposite side of A with respect to BC. The minimum number of points to be located at equal distances on ray BX is
 (A) 5 (B) 8 (C) 13 (D) 3

6. To draw a pair of tangents to a circle which are inclined to each other at an angle of 60° , it is required to draw tangents at end points of those two radii of the circle, the angle between them should be
 (A) 135° (B) 90° (C) 60° (D) 120°

(C) Short Answer Questions with Reasoning

Write True or False and give reasons for your answer.

Sample Questions 1 : By geometrical construction, it is possible to divide a line segment in the ratio $2 + \sqrt{3} : 2 - \sqrt{3}$.

Solution : False. As $2 + \sqrt{3} : 2 - \sqrt{3}$ can be simplified as $7 + 4\sqrt{3} : 1$ and $7 + 4\sqrt{3}$ is not a positive integer, while 1 is.

EXERCISE 10.2

Write True or False and give reasons for your answer in each of the following:

1. By geometrical construction, it is possible to divide a line segment in the ratio

$$\sqrt{3} : \frac{1}{\sqrt{3}}.$$

2. To construct a triangle similar to a given $\triangle ABC$ with its sides $\frac{7}{3}$ of the corresponding sides of $\triangle ABC$, draw a ray BX making acute angle with BC and X lies on the opposite side of A with respect to BC . The points B_1, B_2, \dots, B_7 are located at equal distances on BX , B_3 is joined to C and then a line segment B_6C' is drawn parallel to B_3C where C' lies on BC produced. Finally, line segment $A'C'$ is drawn parallel to AC .
3. A pair of tangents can be constructed from a point P to a circle of radius 3.5 cm situated at a distance of 3 cm from the centre.
4. A pair of tangents can be constructed to a circle inclined at an angle of 170° .

(D) Short Answer Questions

Sample Question 1 : Draw an equilateral triangle ABC of each side 4 cm. Construct a triangle similar to it and of scale factor $\frac{3}{5}$. Is the new triangle also an equilateral?

Solution : Follow the similar steps as given in Mathematics Textbook for Class X. Yes, the new triangle is also equilateral.

EXERCISE 10.3

1. Draw a line segment of length 7 cm. Find a point P on it which divides it in the ratio 3:5.
2. Draw a right triangle ABC in which $BC = 12$ cm, $AB = 5$ cm and $\angle B = 90^\circ$.
Construct a triangle similar to it and of scale factor $\frac{2}{3}$. Is the new triangle also a right triangle?
3. Draw a triangle ABC in which $BC = 6$ cm, $CA = 5$ cm and $AB = 4$ cm.
Construct a triangle similar to it and of scale factor $\frac{5}{3}$.
4. Construct a tangent to a circle of radius 4 cm from a point which is at a distance of 6 cm from its centre.

(E) Long Answer Questions

Sample Questions 1 : Given a rhombus ABCD in which $AB = 4$ cm and $\angle ABC = 60^\circ$, divide it into two triangles say, ABC and ADC. Construct the triangle

$AB'C'$ similar to $\triangle ABC$ with scale factor $\frac{2}{3}$. Draw a line segment $C'D'$ parallel to CD

where D' lies on AD. Is $AB'C'D'$ a rhombus? Give reasons.

Solution : First draw the rhombus ABCD in which $AB = 4$ cm and $\angle ABC = 60^\circ$ as given in Fig. 10.1 and join AC. Construct the triangle $AB'C'$ similar to $\triangle ABC$ with scale

factor $\frac{2}{3}$ as instructed in the

Mathematics Textbook for Class X (See Fig. 10.1).

Finally draw the line segment $C'D'$ parallel to CD.

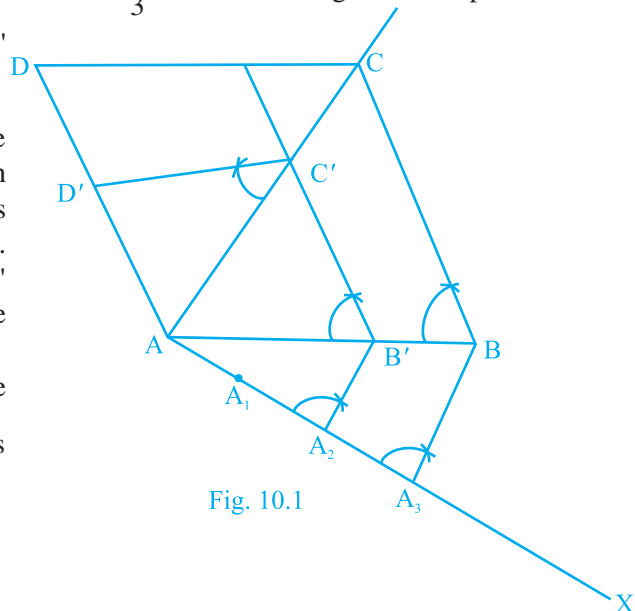

Fig. 10.1

Now
$$\frac{AB'}{AB} = \frac{2}{3} = \frac{A'C'}{AC}$$

Also
$$\frac{AC'}{AC} = \frac{CD'}{CD} = \frac{AD'}{AD} = \frac{2}{3}$$

Therefore, $AB' = B'C' = C'D' = AD' = \frac{2}{3} AB$.

i.e., $AB'C'D'$ is a rhombus.

EXERCISE 10.4

- Two line segments AB and AC include an angle of 60° where $AB = 5$ cm and $AC = 7$ cm. Locate points P and Q on AB and AC , respectively such that

$$AP = \frac{3}{4} AB \text{ and } AQ = \frac{1}{4} AC. \text{ Join } P \text{ and } Q \text{ and measure the length } PQ.$$

- Draw a parallelogram $ABCD$ in which $BC = 5$ cm, $AB = 3$ cm and $\angle ABC = 60^\circ$, divide it into triangles BCD and ABD by the diagonal BD .

Construct the triangle $BD'C'$ similar to $\triangle BDC$ with scale factor $\frac{4}{3}$. Draw the line segment $D'A'$ parallel to DA where A' lies on extended side BA . Is $A'BC'D'$ a parallelogram?

- Draw two concentric circles of radii 3 cm and 5 cm. Taking a point on outer circle construct the pair of tangents to the other. Measure the length of a tangent and verify it by actual calculation.
- Draw an isosceles triangle ABC in which $AB = AC = 6$ cm and $BC = 5$ cm. Construct a triangle PQR similar to $\triangle ABC$ in which $PQ = 8$ cm. Also justify the construction.

- Draw a triangle ABC in which $AB = 5$ cm, $BC = 6$ cm and $\angle ABC = 60^\circ$.

Construct a triangle similar to $\triangle ABC$ with scale factor $\frac{5}{7}$. Justify the construction.

6. Draw a circle of radius 4 cm. Construct a pair of tangents to it, the angle between which is 60° . Also justify the construction. Measure the distance between the centre of the circle and the point of intersection of tangents.
7. Draw a triangle ABC in which $AB = 4$ cm, $BC = 6$ cm and $AC = 9$ cm. Construct a triangle similar to $\triangle ABC$ with scale factor $\frac{3}{2}$. Justify the construction. Are the two triangles congruent? Note that all the three angles and two sides of the two triangles are equal.

AREA RELATED TO CIRCLES

(A) Main Concepts and Results

Perimeters and areas of simple closed figures. Circumference and area of a circle. Area of a circular path (i.e., ring). Sector of a circle and its central angle – Major and Minor sectors. Segment of a circle – Major and Minor segments.

- Circumference of a circle = $2 \pi r$ and area of a circle = πr^2 , where r is the radius of the circle.
- Area of the circular path formed by two concentric circles of radii r_1 and r_2 ($r_1 > r_2$) = $\pi r_1^2 - \pi r_2^2 = \pi(r_1^2 - r_2^2)$.
- Area of the sector of a circle of radius r with central angle $\theta = \frac{\theta}{360} \times \pi r^2$, where θ is measured in degrees.
- Length of the arc of the sector of a circle of radius r with central angle $\theta = \frac{\theta}{360} \times 2 \pi r$, where θ is measured in degrees.
- Area of the minor segment APB of the circle in Fig. 11.1 = area of sector OAPB – area of Δ OAB.
- Area of the major sector of a circle of radius r = πr^2 – area of the corresponding minor sector.

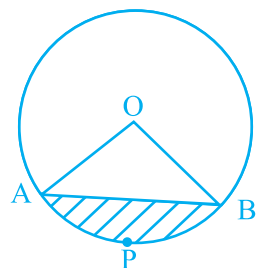

Fig. 11.1

- Area of the major segment of a circle of radius $r = \pi r^2 - \text{area of the corresponding minor segment.}$

Note: Unless stated otherwise, the value of π is to be taken as $\frac{22}{7}$.

(B) Multiple Choice Questions

Choose the correct answer from the given four options:

Sample Question 1 : If the area of a circle is 154 cm^2 , then its perimeter is

- (A) 11 cm (B) 22 cm (C) 44 cm (D) 55 cm

Solution : Answer (C)

Sample Question 2 : If θ is the angle (in degrees) of a sector of a circle of radius r , then area of the sector is

- (A) $\frac{\pi r^2 \theta}{360}$ (B) $\frac{\pi r^2 \theta}{180}$ (C) $\frac{2 \pi r \theta}{360}$ (D) $\frac{2 \pi r \theta}{180}$

Solution : Answer (A)

EXERCISE 11.1

Choose the correct answer from the given four options:

1. If the sum of the areas of two circles with radii R_1 and R_2 is equal to the area of a circle of radius R , then

- (A) $R_1 + R_2 = R$ (B) $R_1^2 + R_2^2 = R^2$
 (C) $R_1 + R_2 < R$ (D) $R_1^2 + R_2^2 < R^2$

2. If the sum of the circumferences of two circles with radii R_1 and R_2 is equal to the circumference of a circle of radius R , then

- (A) $R_1 + R_2 = R$ (B) $R_1 + R_2 > R$
 (C) $R_1 + R_2 < R$ (D) Nothing definite can be said about the relation among R_1 , R_2 and R .

3. If the circumference of a circle and the perimeter of a square are equal, then
- (A) Area of the circle = Area of the square
 - (B) Area of the circle > Area of the square
 - (C) Area of the circle < Area of the square
 - (D) Nothing definite can be said about the relation between the areas of the circle and square.
4. Area of the largest triangle that can be inscribed in a semi-circle of radius r units is
- (A) r^2 sq. units
 - (B) $\frac{1}{2} r^2$ sq. units
 - (C) $2 r^2$ sq. units
 - (D) $\sqrt{2} r^2$ sq. units
5. If the perimeter of a circle is equal to that of a square, then the ratio of their areas is
- (A) 22 : 7
 - (B) 14 : 11
 - (C) 7 : 22
 - (D) 11 : 14
6. It is proposed to build a single circular park equal in area to the sum of areas of two circular parks of diameters 16 m and 12 m in a locality. The radius of the new park would be
- (A) 10 m
 - (B) 15 m
 - (C) 20 m
 - (D) 24 m
7. The area of the circle that can be inscribed in a square of side 6 cm is
- (A) $36 \pi \text{ cm}^2$
 - (B) $18 \pi \text{ cm}^2$
 - (C) $12 \pi \text{ cm}^2$
 - (D) $9 \pi \text{ cm}^2$
8. The area of the square that can be inscribed in a circle of radius 8 cm is
- (A) 256 cm^2
 - (B) 128 cm^2
 - (C) $64\sqrt{2} \text{ cm}^2$
 - (D) 64 cm^2
9. The radius of a circle whose circumference is equal to the sum of the circumferences of the two circles of diameters 36cm and 20 cm is
- (A) 56 cm
 - (B) 42 cm
 - (C) 28 cm
 - (D) 16 cm
10. The diameter of a circle whose area is equal to the sum of the areas of the two circles of radii 24 cm and 7 cm is
- (A) 31 cm
 - (B) 25 cm
 - (C) 62 cm
 - (D) 50 cm

(C) Short Answer Questions with Reasoning

Sample Question 1 : Is the following statement true? Give reasons for your answer.

Area of a segment of a circle = area of the corresponding sector – area of the corresponding triangle.

Solution : Statement is not true. It is true only for a minor segment. In the case of a major segment, area of the triangle will have to be added to the corresponding area of the sector.

Sample Question 2 : In Fig. 11.2, a circle is inscribed in a square of side 5 cm and another circle is circumscribing the square. Is it true to say that area of the outer circle is two times the area of the inner circle? Give reasons for your answer.

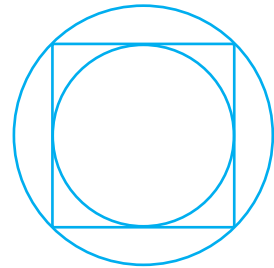

Fig.11.2

Solution : It is true, because diameter of the inner circle = 5 cm and that of outer circle = diagonal of the square = $5\sqrt{2}$ cm.

$$\text{So, } A_1 = \pi \left(\frac{5\sqrt{2}}{2} \right)^2 \text{ and } A_2 = \pi \left(\frac{5}{2} \right)^2, \text{ giving } \frac{A_1}{A_2} = 2$$

EXERCISE 11.2

1. Is the area of the circle inscribed in a square of side a cm, πa^2 cm²? Give reasons for your answer.
2. Will it be true to say that the perimeter of a square circumscribing a circle of radius a cm is $8a$ cm? Give reasons for your answer.
3. In Fig 11.3, a square is inscribed in a circle of diameter d and another square is circumscribing the circle. Is the area of the outer square four times the area of the inner square? Give reasons for your answer.

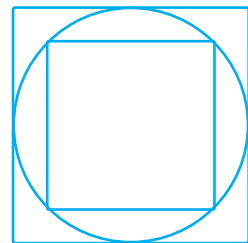

Fig.11.3

4. Is it true to say that area of a segment of a circle is less than the area of its corresponding sector? Why?
5. Is it true that the distance travelled by a circular wheel of diameter d cm in one revolution is $2\pi d$ cm? Why?
6. In covering a distance s metres, a circular wheel of radius r metres makes $\frac{s}{2\pi r}$ revolutions. Is this statement true? Why?
7. The numerical value of the area of a circle is greater than the numerical value of its circumference. Is this statement true? Why?
8. If the length of an arc of a circle of radius r is equal to that of an arc of a circle of radius $2r$, then the angle of the corresponding sector of the first circle is double the angle of the corresponding sector of the other circle. Is this statement false? Why?
9. The areas of two sectors of two different circles with equal corresponding arc lengths are equal. Is this statement true? Why?
10. The areas of two sectors of two different circles are equal. Is it necessary that their corresponding arc lengths are equal? Why?
11. Is the area of the largest circle that can be drawn inside a rectangle of length a cm and breadth b cm ($a > b$) is πb^2 cm²? Why?
12. Circumferences of two circles are equal. Is it necessary that their areas be equal? Why?
13. Areas of two circles are equal. Is it necessary that their circumferences are equal? Why?
14. Is it true to say that area of a square inscribed in a circle of diameter p cm is p^2 cm²? Why?

(D) Short Answer Questions

Sample Question 1: Find the diameter of the circle whose area is equal to the sum of the areas of the two circles of diameters 20 cm and 48 cm.

Solution : Here, radius r_1 of first circle = $\frac{20}{2}$ cm = 10 cm and radius r_2 of the second circle = $\frac{48}{2}$ cm = 24 cm

Therefore, sum of their areas = $\pi r_1^2 + \pi r_2^2 = \pi (10)^2 + \pi (24)^2 = \pi \times 676$ (1)

Let the radius of the new circle be r cm. Its area = πr^2 (2)

Therefore, from (1) and (2),

$$\pi r^2 = \pi \times 676$$

or $r^2 = 676$

i.e., $r = 26$

Thus, radius of the new circle = 26 cm

Hence, diameter of the new circle = 2×26 cm = 52 cm

Sample Question 2 : Find the area of a sector of circle of radius 21 cm and central angle 120° .

Solution : Area of the sector = $\frac{\theta}{360} \times \pi r^2$

$$\begin{aligned} &= \frac{120}{360} \times \frac{22}{7} \times (21)^2 \text{ cm}^2 \\ &= 22 \times 21 \text{ cm}^2 \\ &= 462 \text{ cm}^2 \end{aligned}$$

Sample Question 3 : In Fig 11.4, a circle of radius 7.5 cm is inscribed in a square. Find the area of the shaded region (Use $\pi = 3.14$)

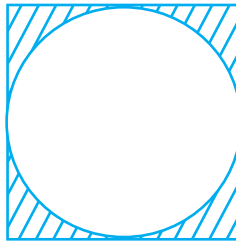

Fig.11.4

Solution : Area of the circle = πr^2

$$= 3.14 \times (7.5)^2 \text{ cm}^2$$

$$= 176.625 \text{ cm}^2$$

Clearly, side of the square = diameter of the circle = 15 cm

So, area of the square = $15^2 \text{ cm}^2 = 225 \text{ cm}^2$

Therefore, area of the shaded region

$$= 225 \text{ cm}^2 - 176.625 \text{ cm}^2 = 48.375 \text{ cm}^2$$

Sample Question 4 : Area of a sector of a circle of radius 36 cm is $54 \pi \text{ cm}^2$. Find the length of the corresponding arc of the sector.

Solution : Let the central angle (in degrees) be θ .

So,
$$\frac{\pi \times (36)^2 \theta}{360} = 54 \pi$$

or
$$\theta = \frac{54 \times 360}{36 \times 36} = 15$$

Now, length of the arc =
$$\frac{\theta}{360} \times 2\pi r$$

$$= \frac{15}{360} \times 2\pi \times 36 \text{ cm}$$

$$= 3 \pi \text{ cm}$$

EXERCISE 11.3

- Find the radius of a circle whose circumference is equal to the sum of the circumferences of two circles of radii 15 cm and 18 cm.
- In Fig. 11.5, a square of diagonal 8 cm is inscribed in a circle. Find the area of the shaded region.

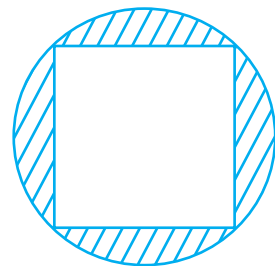

Fig.11.5

3. Find the area of a sector of a circle of radius 28 cm and central angle 45° .
4. The wheel of a motor cycle is of radius 35 cm. How many revolutions per minute must the wheel make so as to keep a speed of 66 km/h?
5. A cow is tied with a rope of length 14 m at the corner of a rectangular field of dimensions $20\text{m} \times 16\text{m}$. Find the area of the field in which the cow can graze.
6. Find the area of the flower bed (with semi-circular ends) shown in Fig. 11.6.

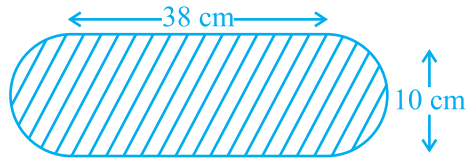

Fig. 11.6

7. In Fig. 11.7, AB is a diameter of the circle, AC = 6 cm and BC = 8 cm. Find the area of the shaded region (Use $\pi = 3.14$).

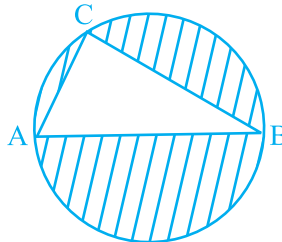

Fig. 11.7

8. Find the area of the shaded field shown in Fig. 11.8.

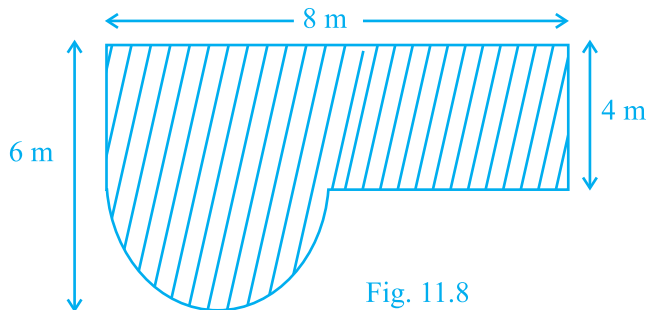

Fig. 11.8

9. Find the area of the shaded region in Fig. 11.9.

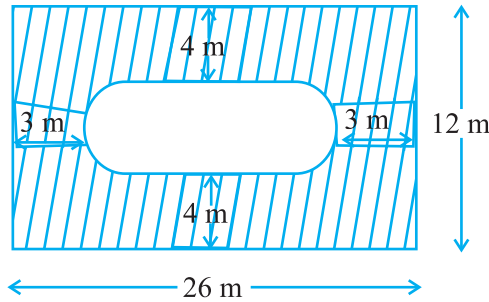

Fig. 11.9

10. Find the area of the minor segment of a circle of radius 14 cm, when the angle of the corresponding sector is 60° .
11. Find the area of the shaded region in Fig. 11.10, where arcs drawn with centres A, B, C and D intersect in pairs at mid-points P, Q, R and S of the sides AB, BC, CD and DA, respectively of a square ABCD (Use $\pi = 3.14$).

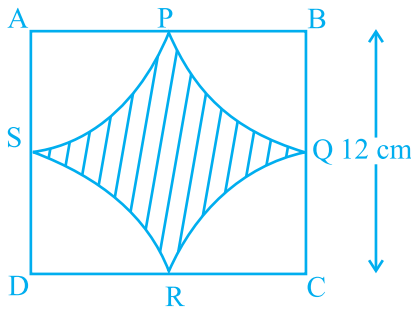

Fig. 11.10

12. In Fig. 11.11, arcs are drawn by taking vertices A, B and C of an equilateral triangle of side 10 cm. to intersect the sides BC, CA and AB at their respective mid-points D, E and F. Find the area of the shaded region (Use $\pi = 3.14$).

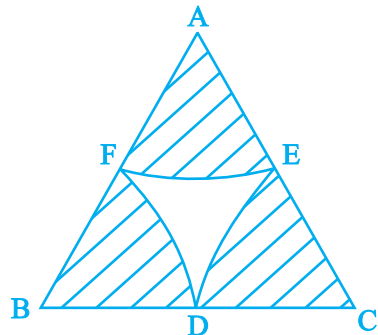

Fig. 11.11

13. In Fig. 11.12, arcs have been drawn with radii 14 cm each and with centres P, Q and R. Find the area of the shaded region.

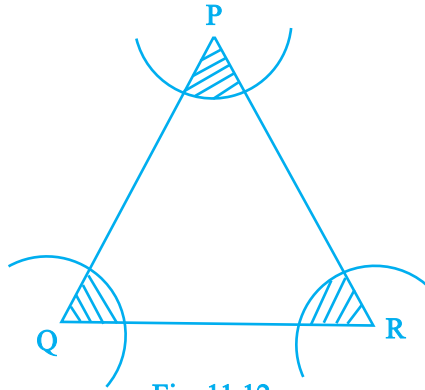

Fig. 11.12

14. A circular park is surrounded by a road 21 m wide. If the radius of the park is 105 m, find the area of the road.
15. In Fig. 11.13, arcs have been drawn of radius 21 cm each with vertices A, B, C and D of quadrilateral ABCD as centres. Find the area of the shaded region.

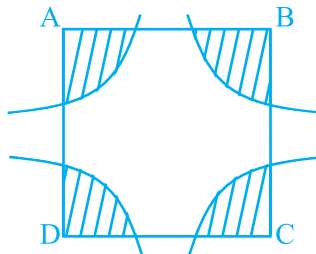

Fig. 11.13

16. A piece of wire 20 cm long is bent into the form of an arc of a circle subtending an angle of 60° at its centre. Find the radius of the circle.

(E) Long Answer Questions

Sample Question 1 : A chord of a circle of radius 20 cm subtends an angle of 90° at the centre. Find the area of the corresponding major segment of the circle. (Use $\pi = 3.14$).

Solution : Let AB be the chord of a circle of radius 10 cm, with O as the centre of the circle (see Fig. 11.14).

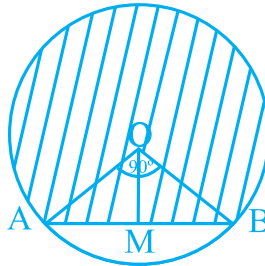

Fig. 11.14

Here, $\angle A O B = 90^\circ$ and we have to find the area of the major segment (which is shaded). As $\angle AOB = 90^\circ$, therefore angle of the major sector = $360^\circ - 90^\circ = 270^\circ$

$$\begin{aligned} \text{So, area of the major sector} &= \frac{270}{360} \times \pi \times (10)^2 \text{ cm}^2 \\ &= \frac{3}{4} \times 3.14 \times 100 \text{ cm}^2 \\ &= 75 \times 3.14 \text{ cm}^2 = 235.5 \text{ cm}^2 \end{aligned}$$

Now, to find the area of ΔOAB , draw $OM \perp AB$.

$$\text{So, } AM = \frac{1}{2} AB \text{ and } \angle AOM = \frac{1}{2} \times 90^\circ = 45^\circ.$$

$$\text{Now, } \frac{AM}{OA} = \sin 45^\circ = \frac{1}{\sqrt{2}}$$

$$\text{So, } AM = 10 \times \frac{1}{\sqrt{2}} \text{ cm.}$$

$$\text{Therefore, } AB = 10\sqrt{2} \text{ cm and } OM = OA \cos 45^\circ = 10 \times \frac{1}{\sqrt{2}} \text{ cm} = 5\sqrt{2} \text{ cm}$$

$$\text{So, area of } \Delta OAB = \frac{1}{2} \text{ base} \times \text{height}$$

$$= \frac{1}{2} 10\sqrt{2} \times 5\sqrt{2} \text{ cm}^2 = 50 \text{ cm}^2$$

Therefore, the area of the required major segment
 $= 235.5 \text{ cm}^2 + 50 \text{ cm}^2 = 285.5 \text{ cm}^2$

Another method for the area of ΔOAB

As, $\angle AOB = 90^\circ$,

Therefore, area of $\Delta OAB = \frac{1}{2} OA \times OB$

$$= \frac{1}{2} 10 \times 10 \text{ cm}^2 = 50 \text{ cm}^2$$

Sample Question 2 : With the vertices A, B and C of a triangle ABC as centres, arcs are drawn with radii 5 cm each as shown in Fig. 11.15. If $AB = 14$ cm, $BC = 48$ cm and $CA = 50$ cm, then find the area of the shaded region. (Use $\pi = 3.14$).

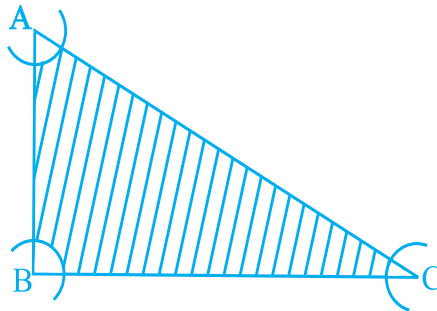

Fig. 11.15

Solution : Area of the sector with angle A

$$= \frac{\angle A}{360^\circ} \times \pi r^2 = \frac{\angle A}{360^\circ} \times \pi \times (5)^2 \text{ cm}^2$$

Area of the sector with angle B

$$= \frac{\angle B}{360^\circ} \times \pi r^2 = \frac{\angle B}{360^\circ} \times \pi \times (5)^2 \text{ cm}^2$$

and the area of the sector with angle C = $\frac{\angle C}{360^\circ} \times \pi \times (5)^2 \text{ cm}^2$

Therefore, sum of the areas (in cm^2) of the three sectors

$$\begin{aligned} &= \frac{\angle A}{360^\circ} \times \pi \times (5)^2 + \frac{\angle B}{360^\circ} \times \pi \times (5)^2 + \frac{\angle C}{360^\circ} \times \pi \times (5)^2 \\ &= \frac{\angle A + \angle B + \angle C}{360^\circ} \times 25 \pi \\ &= \frac{180^\circ}{360^\circ} \times 25 \pi \text{ cm}^2 \quad (\text{Because } \angle A + \angle B + \angle C = 180^\circ) \\ &= 25 \times \frac{\pi}{2} \text{ cm}^2 = 25 \times 1.57 \text{ cm}^2 = 39.25 \text{ cm}^2 \end{aligned}$$

Now, to find area of ΔABC , we find

$$s = \frac{a + b + c}{2} = \frac{48 + 50 + 14}{2} \text{ cm} = 56 \text{ cm}$$

By Heron's Formula,

$$\begin{aligned} \text{ar (ABC)} &= \sqrt{s(s-a)(s-b)(s-c)} \\ &= \sqrt{56 \times 8 \times 6 \times 42} \text{ cm}^2 \\ &= 336 \text{ cm}^2 \end{aligned}$$

So, area of the shaded region = area of the ΔABC – area of the three sectors
 $= (336 - 39.25) \text{ cm}^2 = 296.75 \text{ cm}^2$

Alternate Method for ar (ABC)

Here, $AB^2 + BC^2 = (14)^2 + (48)^2 = 2500 = (50)^2 = (CA)^2$

So, $\angle B = 90^\circ$ (By converse of Pythagoras Theorem)

Therefore, $\text{ar (ABC)} = \frac{1}{2} AB \times BC = \frac{1}{2} \times 14 \times 48 \text{ cm}^2 = 336 \text{ cm}^2$

Sample Question 3 : A calf is tied with a rope of length 6 m at the corner of a square grassy lawn of side 20 m. If the length of the rope is increased by 5.5m, find the increase in area of the grassy lawn in which the calf can graze.

Solution : Let the calf be tied at the corner A of the square lawn (see Fig. 11.16)

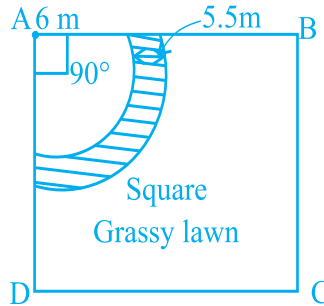

Fig. 11.16

Then, the increase in area = Difference of the two sectors of central angle 90° each and radii 11.5 m (6 m + 5.5 m) and 6 m, which is the shaded region in the figure.

So, required increase in area

$$\begin{aligned}
 &= \left[\frac{90}{360} \times \pi \times 11.5^2 - \frac{90}{360} \pi \times 6^2 \right] \text{m}^2 \\
 &= \frac{\pi}{4} \times (11.5 + 6) (11.5 - 6) \text{m}^2 \\
 &= \frac{22}{7 \times 4} \times 17.5 \times 5.5 \text{m}^2 \\
 &= 75.625 \text{m}^2.
 \end{aligned}$$

EXERCISE 11.4

1. The area of a circular playground is 22176 m^2 . Find the cost of fencing this ground at the rate of Rs 50 per metre.
2. The diameters of front and rear wheels of a tractor are 80 cm and 2 m respectively. Find the number of revolutions that rear wheel will make in covering a distance in which the front wheel makes 1400 revolutions.
3. Sides of a triangular field are 15 m, 16 m and 17 m. With the three corners of the field a cow, a buffalo and a horse are tied separately with ropes of length 7 m each to graze in the field. Find the area of the field which cannot be grazed by the three animals.

4. Find the area of the segment of a circle of radius 12 cm whose corresponding sector has a central angle of 60° (Use $\pi = 3.14$).
5. A circular pond is 17.5 m is of diameter. It is surrounded by a 2 m wide path. Find the cost of constructing the path at the rate of Rs 25 per m^2
6. In Fig. 11.17, ABCD is a trapezium with $AB \parallel DC$, $AB = 18$ cm, $DC = 32$ cm and distance between AB and DC = 14 cm. If arcs of equal radii 7 cm with centres A, B, C and D have been drawn, then find the area of the shaded region of the figure.

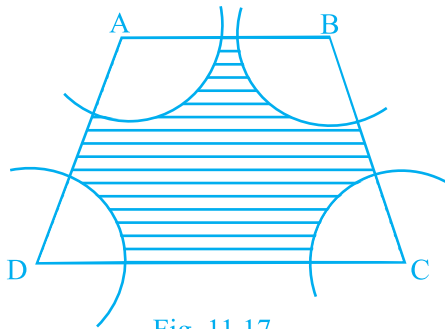

Fig. 11.17

7. Three circles each of radius 3.5 cm are drawn in such a way that each of them touches the other two. Find the area enclosed between these circles.
8. Find the area of the sector of a circle of radius 5 cm, if the corresponding arc length is 3.5 cm.
9. Four circular cardboard pieces of radii 7 cm are placed on a paper in such a way that each piece touches other two pieces. Find the area of the portion enclosed between these pieces.
10. On a square cardboard sheet of area 784 cm^2 , four congruent circular plates of maximum size are placed such that each circular plate touches the other two plates and each side of the square sheet is tangent to two circular plates. Find the area of the square sheet not covered by the circular plates.
11. Floor of a room is of dimensions $5 \text{ m} \times 4 \text{ m}$ and it is covered with circular tiles of diameters 50 cm each as shown in Fig. 11.18. Find the area of floor

that remains uncovered with tiles. (Use $\pi = 3.14$)

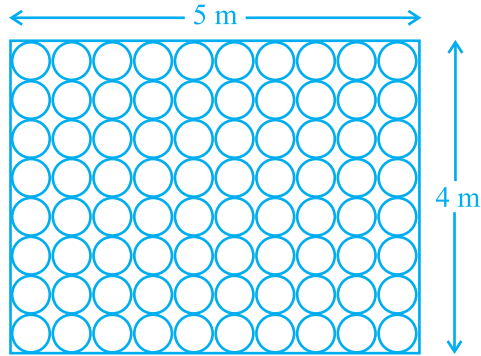

Fig. 11.18

12. All the vertices of a rhombus lie on a circle. Find the area of the rhombus, if area of the circle is 1256 cm^2 . (Use $\pi = 3.14$).
13. An archery target has three regions formed by three concentric circles as shown in Fig. 11.19. If the diameters of the concentric circles are in the ratio 1: 2:3, then find the ratio of the areas of three regions.

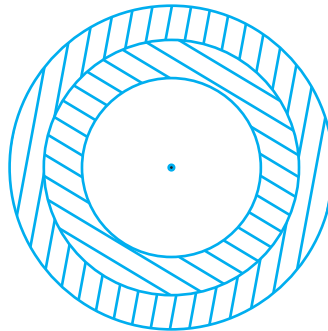

Fig. 11.19

14. The length of the minute hand of a clock is 5 cm. Find the area swept by the minute hand during the time period 6 : 05 a m and 6 : 40 a m.
15. Area of a sector of central angle 200° of a circle is 770 cm^2 . Find the length of the corresponding arc of this sector.

16. The central angles of two sectors of circles of radii 7 cm and 21 cm are respectively 120° and 40° . Find the areas of the two sectors as well as the lengths of the corresponding arcs. What do you observe?
17. Find the area of the shaded region given in Fig. 11.20.

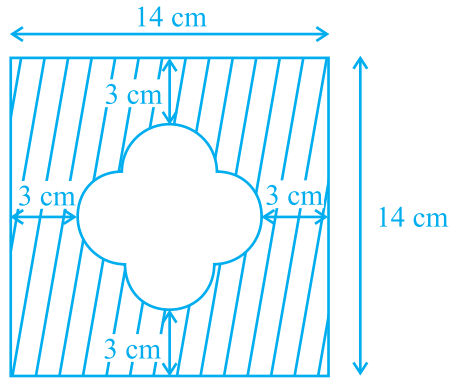

Fig. 11.20

18. Find the number of revolutions made by a circular wheel of area 1.54 m^2 in rolling a distance of 176 m.
19. Find the difference of the areas of two segments of a circle formed by a chord of length 5 cm subtending an angle of 90° at the centre.
20. Find the difference of the areas of a sector of angle 120° and its corresponding major sector of a circle of radius 21 cm.

SURFACE AREAS AND VOLUMES

(A) Main Concepts and Results

- The surface area of an object formed by combining any two of the basic solids, namely, cuboid, cone, cylinder, sphere and hemisphere.
- The volume of an object formed by combining any two of the basic solids namely, cuboid, cone, cylinder, sphere and hemisphere.
- The formulae involving the frustum of a cone are:
 - (i) Volume of the frustum of the cone $= \frac{1}{3}\pi h[r_1^2 + r_2^2 + r_1r_2]$
 - (ii) Curved surface area of the frustum of the cone $= \pi(r_1+r_2)l$,
 - (iii) Total surface area of the frustum of the solid cone $= \pi l(r_1+r_2) + \pi r_1^2 + \pi r_2^2$, where $l = \sqrt{h^2 + (r_1 - r_2)^2}$,
 h = vertical height of the frustum, l = slant height of the frustum and r_1 and r_2 are radii of the two bases (ends) of the frustum.
- Solid hemisphere: If r is the radius of a hemisphere, then
 curved surface area $= 2\pi r^2$
 total surface area $= 3\pi r^2$, and volume $= \frac{2}{3}\pi r^3$
- Volume of a spherical shell $= \frac{4}{3}\pi(r_1^3 - r_2^3)$, where r_1 and r_2 are respectively its external and internal radii.
 Throughout this chapter, take $\pi = \frac{22}{7}$, if not stated otherwise.

(B) Multiple Choice Questions :

Choose the correct answer from the given four options:



Fig. 12.1

Sample Question 1 : A funnel (see Fig.12.1) is the combination of

- (A) a cone and a cylinder (B) frustum of a cone and a cylinder
(C) a hemisphere and a cylinder (D) a hemisphere and a cone

Solution : Answer (B)

Sample Question 2 : If a marble of radius 2.1 cm is put into a cylindrical cup full of water of radius 5cm and height 6 cm, then how much water flows out of the cylindrical cup?

- (A) 38.8 cm³ (B) 55.4 cm³ (C) 19.4 cm³ (D) 471.4 cm³

Solution : Answer (A)

Sample Question 3 : A cubical ice cream brick of edge 22 cm is to be distributed among some children by filling ice cream cones of radius 2 cm and height 7 cm upto its brim. How many children will get the ice cream cones?

- (A) 163 (B) 263 (C) 363 (D) 463

Solution : Answer (C)

Sample Question 4 : The radii of the ends of a frustum of a cone of height h cm are r_1 cm and r_2 cm. The volume in cm³ of the frustum of the cone is

- (A) $\frac{1}{3}\pi h[r_1^2 + r_2^2 + r_1 r_2]$ (B) $\frac{1}{3}\pi h[r_1^2 + r_2^2 - r_1 r_2]$
(C) $\frac{1}{3}\pi h[r_1^2 - r_2^2 + r_1 r_2]$ (D) $\frac{1}{3}\pi h[r_1^2 - r_2^2 - r_1 r_2]$

Solution : Answer (A)

Sample Question 5 : The volume of the largest right circular cone that can be cut out from a cube of edge 4.2 cm is

- (A) 9.7 cm³ (B) 77.6 cm³ (C) 58.2 cm³ (D) 19.4 cm³

Solution : Answer (D)

EXERCISE 12.1

Choose the correct answer from the given four options:

- A cylindrical pencil sharpened at one edge is the combination of

(A) a cone and a cylinder	(B) frustum of a cone and a cylinder
(C) a hemisphere and a cylinder	(D) two cylinders.
- A *surahi* is the combination of

(A) a sphere and a cylinder	(B) a hemisphere and a cylinder
(C) two hemispheres	(D) a cylinder and a cone.
- A plumbline (*sahul*) is the combination of (see Fig. 12.2)

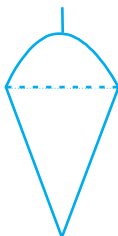

Fig. 12.2

- | | |
|--------------------------------------|-----------------------------|
| (A) a cone and a cylinder | (B) a hemisphere and a cone |
| (C) frustum of a cone and a cylinder | (D) sphere and cylinder |
- The shape of a glass (tumbler) (see Fig. 12.3) is usually in the form of

(A) a cone	(B) frustum of a cone
(C) a cylinder	(D) a sphere



Fig. 12.3

5. The shape of a *gilli*, in the *gilli-danda* game (see Fig. 12.4), is a combination of
- (A) two cylinders (B) a cone and a cylinder
(C) two cones and a cylinder (D) two cylinders and a cone



Fig. 12.4

6. A shuttle cock used for playing badminton has the shape of the combination of
- (A) a cylinder and a sphere (B) a cylinder and a hemisphere
(C) a sphere and a cone (D) frustum of a cone and a hemisphere
7. A cone is cut through a plane parallel to its base and then the cone that is formed on one side of that plane is removed. The new part that is left over on the other side of the plane is called
- (A) a frustum of a cone (B) cone
(C) cylinder (D) sphere
8. A hollow cube of internal edge 22cm is filled with spherical marbles of diameter 0.5 cm and it is assumed that $\frac{1}{8}$ space of the cube remains unfilled. Then the number of marbles that the cube can accommodate is
- (A) 142296 (B) 142396 (C) 142496
(D) 142596
9. A metallic spherical shell of internal and external diameters 4 cm and 8 cm, respectively is melted and recast into the form a cone of base diameter 8cm. The height of the cone is
- (A) 12cm (B) 14cm (C) 15cm (D) 18cm
10. A solid piece of iron in the form of a cuboid of dimensions 49cm × 33cm × 24cm, is moulded to form a solid sphere. The radius of the sphere is
- (A) 21cm (B) 23cm (C) 25cm (D) 19cm
11. A mason constructs a wall of dimensions 270cm × 300cm × 350cm with the bricks each of size 22.5cm × 11.25cm × 8.75cm and it is assumed that $\frac{1}{8}$ space is

- covered by the mortar. Then the number of bricks used to construct the wall is
- (A) 11100 (B) 11200 (C) 11000 (D) 11300
- 12.** Twelve solid spheres of the same size are made by melting a solid metallic cylinder of base diameter 2 cm and height 16 cm. The diameter of each sphere is
- (A) 4 cm (B) 3 cm (C) 2 cm (D) 6 cm
- 13.** The radii of the top and bottom of a bucket of slant height 45 cm are 28 cm and 7 cm, respectively. The curved surface area of the bucket is
- (A) 4950 cm² (B) 4951 cm² (C) 4952 cm² (D) 4953 cm²
- 14.** A medicine-capsule is in the shape of a cylinder of diameter 0.5 cm with two hemispheres stuck to each of its ends. The length of entire capsule is 2 cm. The capacity of the capsule is
- (A) 0.36 cm³ (B) 0.35 cm³ (C) 0.34 cm³ (D) 0.33 cm³
- 15.** If two solid hemispheres of same base radius r are joined together along their bases, then curved surface area of this new solid is
- (A) $4\pi r^2$ (B) $6\pi r^2$ (C) $3\pi r^2$ (D) $8\pi r^2$
- 16.** A right circular cylinder of radius r cm and height h cm ($h > 2r$) just encloses a sphere of diameter
- (A) r cm (B) $2r$ cm (C) h cm (D) $2h$ cm
- 17.** During conversion of a solid from one shape to another, the volume of the new shape will
- (A) increase (B) decrease (C) remain unaltered (D) be doubled
- 18.** The diameters of the two circular ends of the bucket are 44 cm and 24 cm. The height of the bucket is 35 cm. The capacity of the bucket is
- (A) 32.7 litres (B) 33.7 litres (C) 34.7 litres (D) 31.7 litres
- 19.** In a right circular cone, the cross-section made by a plane parallel to the base is a
- (A) circle (B) frustum of a cone (C) sphere (D) hemisphere
- 20.** Volumes of two spheres are in the ratio 64:27. The ratio of their surface areas is
- (A) 3 : 4 (B) 4 : 3 (C) 9 : 16 (D) 16 : 9

(C) Short Answer Questions with Reasoning

Write 'True' or 'False' and justify your answer.

Sample Question 1 : If a solid cone of base radius r and height h is placed over a solid cylinder having same base radius and height as that of the cone, then the curved surface area of the shape is $\pi r \sqrt{h^2 + r^2} + 2\pi r h$.

Solution : True. Since the curved surface area taken together is same as the sum of curved surface areas measured separately.

Sample Question 2 : A spherical steel ball is melted to make eight new identical balls.

Then, the radius of each new ball be $\frac{1}{8}$ th the radius of the original ball.

Solution : False. Let r be the radius of the original steel ball and r_1 be the radius of the new ball formed after melting.

Therefore, $\frac{4}{3} \pi r^3 = 8 \times \frac{4}{3} \pi r_1^3$. This implies $r_1 = \frac{r}{2}$.

Sample Question 3 : Two identical solid cubes of side a are joined end to end. Then the total surface area of the resulting cuboid is $12a^2$.

Solution : False. The total surface area of a cube having side a is $6a^2$. If two identical faces of side a are joined together, then the total surface area of the cuboid so formed is $10a^2$.

Sample Question 4 : Total surface area of a *lattu* (top) as shown in the Fig. 12.5 is the sum of total surface area of hemisphere and the total surface area of cone.

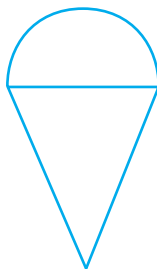

Fig. 12.5

Solution : False. Total surface area of the lattu is the sum of the curved surface area of the hemisphere and curved surface area of the cone.

Sample Question 5 : Actual capacity of a vessel as shown in the Fig. 12.6 is equal to the difference of volume of the cylinder and volume of the hemisphere.

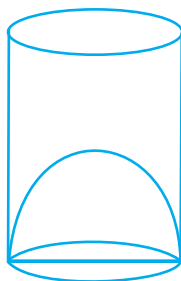

Fig. 12.6

Solution : True. Actual capacity of the vessel is the empty space inside the glass that can accommodate something when poured in it.

EXERCISE 12.2

Write 'True' or 'False' and justify your answer in the following:

- Two identical solid hemispheres of equal base radius r cm are stuck together along their bases. The total surface area of the combination is $6\pi r^2$.
- A solid cylinder of radius r and height h is placed over other cylinder of same height and radius. The total surface area of the shape so formed is $4\pi rh + 4\pi r^2$.
- A solid cone of radius r and height h is placed over a solid cylinder having same base radius and height as that of a cone. The total surface area of the combined solid is $\pi[\sqrt{r^2 + h^2} + 3r + 2h]$.
- A solid ball is exactly fitted inside the cubical box of side a . The volume of the ball is $\frac{4}{3}\pi a^3$.
- The volume of the frustum of a cone is $\frac{1}{3}\pi h[r_1^2 + r_2^2 + r_1 r_2]$, where h is vertical height of the frustum and r_1, r_2 are the radii of the ends.
- The capacity of a cylindrical vessel with a hemispherical portion raised upward at the bottom as shown in the Fig. 12.7 is $\frac{\pi r^2}{3}[3h - 2r]$.

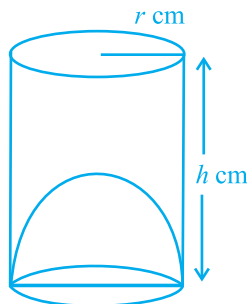

Fig. 12.7

7. The curved surface area of a frustum of a cone is $\pi l (r_1 + r_2)$, where $l = \sqrt{h^2 + (r_1 - r_2)^2}$, r_1 and r_2 are the radii of the two ends of the frustum and h is the vertical height.
8. An open metallic bucket is in the shape of a frustum of a cone, mounted on a hollow cylindrical base made of the same metallic sheet. The surface area of the metallic sheet used is equal to
curved surface area of frustum of a cone + area of circular base + curved surface area of cylinder

(C) Short Answer Questions

Sample Question 1 : A cone of maximum size is carved out from a cube of edge 14 cm. Find the surface area of the cone and of the remaining solid left out after the cone carved out.

Solution : The cone of maximum size that is carved out from a cube of edge 14 cm will be of base radius 7 cm and the height 14 cm.

Surface area of the cone = $\pi r l + \pi r^2$

$$= \frac{22}{7} \times 7 \times \sqrt{7^2 + 14^2} + \frac{22}{7} (7)^2$$

$$= \frac{22}{7} \times 7 \times \sqrt{245} + 154 = (154\sqrt{5} + 154) \text{ cm}^2 = 154(\sqrt{5} + 1) \text{ cm}^2$$

Surface area of the cube = $6 \times (14)^2 = 6 \times 196 = 1176 \text{ cm}^2$

So, surface area of the remaining solid left out after the cone is carved out

$$= (1176 - 154 + 154\sqrt{5}) \text{ cm}^2 = (1022 + 154\sqrt{5}) \text{ cm}^2.$$

Sample Question 2 : A solid metallic sphere of radius 10.5 cm is melted and recast into a number of smaller cones, each of radius 3.5 cm and height 3 cm. Find the number of cones so formed.

Solution : The volume of the solid metallic sphere = $\frac{4}{3}\pi(10.5)^3 \text{ cm}^3$

Volume of a cone of radius 3.5 cm and height 3 cm = $\frac{1}{3}\pi(3.5)^2 \times 3 \text{ cm}^3$

$$\text{Number of cones so formed} = \frac{\frac{4}{3}\pi \times 10.5 \times 10.5 \times 10.5}{\frac{1}{3}\pi \times 3.5 \times 3.5 \times 3} = 126$$

Sample Question 3 : A canal is 300 cm wide and 120 cm deep. The water in the canal is flowing with a speed of 20 km/h. How much area will it irrigate in 20 minutes if 8 cm of standing water is desired?

Solution : Volume of water flows in the canal in one hour = width of the canal \times depth of the canal \times speed of the canal water = $3 \times 1.2 \times 20 \times 1000 \text{ m}^3 = 72000 \text{ m}^3$.

$$\text{In 20 minutes the volume of water} = \frac{72000 \times 20}{60} \text{ m}^3 = 24000 \text{ m}^3.$$

Area irrigated in 20 minutes, if 8 cm, i.e., 0.08 m standing water is required

$$= \frac{24000}{0.08} \text{ m}^2 = 300000 \text{ m}^2 = 30 \text{ hectares.}$$

Sample Question 4 : A cone of radius 4 cm is divided into two parts by drawing a plane through the mid point of its axis and parallel to its base. Compare the volumes of the two parts.

Solution : Let h be the height of the given cone. On dividing the cone through the mid-point of its axis and parallel to its base into two parts, we obtain the following (see Fig. 12.8):

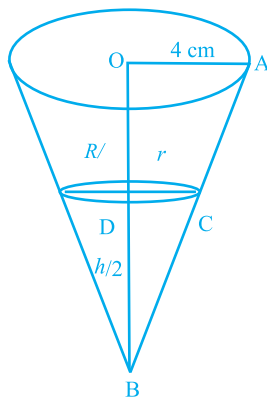

Fig. 12.8

In two similar triangles OAB and DCB, we have $\frac{OA}{CD} = \frac{OB}{BD}$. This implies $\frac{4}{r} = \frac{h}{\frac{h}{2}}$.

Therefore, $r = 2$.

$$\text{Therefore, } \frac{\text{Volume of the smaller cone}}{\text{Volume of the frustum of the cone}} = \frac{\frac{1}{3} \pi \times (2)^2 \times \left(\frac{h}{2}\right)}{\frac{1}{3} \pi \times \left(\frac{h}{2}\right) [4^2 + 2^2 + 4 \times 2]} = \frac{1}{7}$$

Therefore, the ratio of volume of the smaller cone to the volume of the frustum of the cone is 1:7.

Sample Question 5 : Three cubes of a metal whose edges are in the ratio 3:4:5 are melted and converted into a single cube whose diagonal is $12\sqrt{3}$ cm. Find the edges of the three cubes.

Solution : Let the edges of three cubes (in cm) be $3x$, $4x$ and $5x$, respectively.

$$\text{Volume of the cubes after melting is } = (3x)^3 + (4x)^3 + (5x)^3 = 216x^3 \text{ cm}^3$$

Let a be the side of new cube so formed after melting. Therefore, $a^3 = 216x^3$

$$\text{So, } a = 6x, \text{ Diagonal} = \sqrt{a^2 + a^2 + a^2} = a\sqrt{3}$$

But it is given that diagonal of the new cube is $12\sqrt{3}$ cm. Therefore, $a\sqrt{3} = 12\sqrt{3}$, i.e., $a = 12$.

This gives $x = 2$. Therefore, edges of the three cubes are 6 cm, 8 cm and 10 cm, respectively.

EXERCISE 12.3

- Three metallic solid cubes whose edges are 3 cm, 4 cm and 5 cm are melted and formed into a single cube. Find the edge of the cube so formed.
- How many shots each having diameter 3 cm can be made from a cuboidal lead solid of dimensions $9\text{cm} \times 11\text{cm} \times 12\text{cm}$?
- A bucket is in the form of a frustum of a cone and holds 28.490 litres of water. The radii of the top and bottom are 28 cm and 21 cm, respectively. Find the height of the bucket.
- A cone of radius 8 cm and height 12 cm is divided into two parts by a plane through the mid-point of its axis parallel to its base. Find the ratio of the volumes of two parts.
- Two identical cubes each of volume 64 cm^3 are joined together end to end. What is the surface area of the resulting cuboid?
- From a solid cube of side 7 cm, a conical cavity of height 7 cm and radius 3 cm is hollowed out. Find the volume of the remaining solid.
- Two cones with same base radius 8 cm and height 15 cm are joined together along their bases. Find the surface area of the shape so formed.
- Two solid cones A and B are placed in a cylindrical tube as shown in the Fig.12.9. The ratio of their capacities are 2:1. Find the heights and capacities of cones. Also, find the volume of the remaining portion of the cylinder.

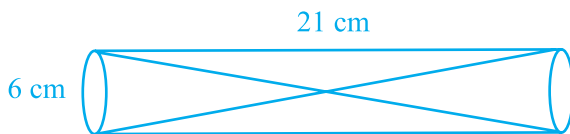

Fig. 12.9

- An ice cream cone full of ice cream having radius 5 cm and height 10 cm as shown in the Fig.12.10. Calculate the volume of ice cream, provided that its $\frac{1}{6}$ part is left unfilled with ice cream.

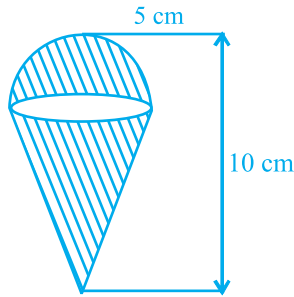

Fig. 12.10

10. Marbles of diameter 1.4 cm are dropped into a cylindrical beaker of diameter 7 cm containing some water. Find the number of marbles that should be dropped into the beaker so that the water level rises by 5.6 cm.
11. How many spherical lead shots each of diameter 4.2 cm can be obtained from a solid rectangular lead piece with dimensions 66 cm, 42 cm and 21 cm.
12. How many spherical lead shots of diameter 4 cm can be made out of a solid cube of lead whose edge measures 44 cm.
13. A wall 24 m long, 0.4 m thick and 6 m high is constructed with the bricks each of dimensions 25 cm \times 16 cm \times 10 cm. If the mortar occupies $\frac{1}{10}$ th of the volume of the wall, then find the number of bricks used in constructing the wall.
14. Find the number of metallic circular disc with 1.5 cm base diameter and of height 0.2 cm to be melted to form a right circular cylinder of height 10 cm and diameter 4.5 cm.

(E) Long Answer Questions

Sample Question 1 : A bucket is in the form of a frustum of a cone of height 30 cm with radii of its lower and upper ends as 10 cm and 20 cm, respectively. Find the capacity and surface area of the bucket. Also, find the cost of milk which can completely fill the container, at the rate of Rs 25 per litre (use $\pi = 3.14$).

Solution : Capacity (or volume) of the bucket = $\frac{\pi h}{3}[r_1^2 + r_2^2 + r_1 r_2]$.

Here, $h = 30$ cm, $r_1 = 20$ cm and $r_2 = 10$ cm.

So, the capacity of bucket = $\frac{3.14 \times 30}{3} [20^2 + 10^2 + 20 \times 10] \text{ cm}^3 = 21.980 \text{ litres}$.

Cost of 1 litre of milk = Rs 25

Cost of 21.980 litres of milk = Rs $21.980 \times 25 = \text{Rs } 549.50$

Surface area of the bucket = curved surface area of the bucket
+ surface area of the bottom

$$= \pi l (r_1 + r_2) + \pi r_2^2, \quad l = \sqrt{h^2 + (r_1 - r_2)^2}$$

Now, $l = \sqrt{900 + 100} \text{ cm} = 31.62 \text{ cm}$

Therefore, surface area of the bucket = $3.14 \times 31.62(20 + 10) + \frac{22}{7}(10)^2$
 $= 3.14 [948.6 + 100] \text{ cm}^2$
 $= 3.14 [1048.6] \text{ cm}^2 = 3292.6 \text{ cm}^2 \text{ (approx.)}$

Sample Question 2 : A solid toy is in the form of a hemisphere surmounted by a right circular cone. The height of the cone is 4 cm and the diameter of the base is 8 cm. Determine the volume of the toy. If a cube circumscribes the toy, then find the difference of the volumes of cube and the toy. Also, find the total surface area of the toy.

Solution : Let r be the radius of the hemisphere and the cone and h be the height of the cone (see Fig. 12.11).

Volume of the toy = Volume of the hemisphere + Volume of the cone

$$= \frac{2}{3} \pi r^3 + \frac{1}{3} \pi r^2 h$$

$$= \left(\frac{2}{3} \times \frac{22}{7} \times 4^3 + \frac{1}{3} \times \frac{22}{7} \times 4^2 \times 4 \right) \text{ cm}^3 = \frac{1408}{7} \text{ cm}^3.$$

A cube circumscribes the given solid. Therefore, edge of the cube should be 8 cm.

Volume of the cube = $8^3 \text{ cm}^3 = 512 \text{ cm}^3$.

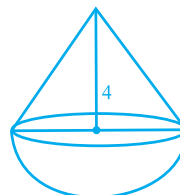

Fig. 12.11

Difference in the volumes of the cube and the toy = $\left(512 - \frac{1408}{7}\right) \text{cm}^3 = 310.86 \text{cm}^3$

$$\begin{aligned}
 \text{Total surface area of the toy} &= \text{Curved surface area of cone} \\
 &\quad + \text{curved surface area of hemisphere} \\
 &= \pi r l + 2\pi r^2, \text{ where } l = \sqrt{h^2 + r^2} \\
 &= \pi r (l + 2r) \\
 &= \frac{22}{7} \times 4 \sqrt{4^2 + 4^2} + 2 \times 4 \text{ cm}^2 \\
 &= \frac{22}{7} \times 4 \cdot 4\sqrt{2} + 8 \text{ cm}^2 \\
 &= \frac{88 \times 4}{7} \sqrt{2} + 8 \text{ cm}^2 \\
 &= 171.68 \text{ cm}^2
 \end{aligned}$$

Sample Question 3 : A building is in the form of a cylinder surmounted by a hemispherical dome (see Fig. 12.12). The

base diameter of the dome is equal to $\frac{2}{3}$ of the total height of the building. Find the height of the building, if it contains $67\frac{1}{21} \text{ m}^3$ of air.

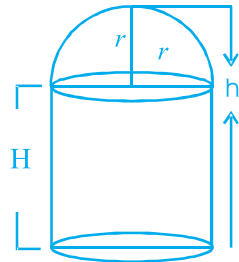

Fig. 12.12

Solution : Let the radius of the hemispherical dome be r metres and the total height of the building be h metres.

Since the base diameter of the dome is equal to $\frac{2}{3}$ of the total height, therefore

$2r = \frac{2}{3}h$. This implies $r = \frac{h}{3}$. Let H metres be the height of the cylindrical portion.

Therefore, $H = h - \frac{h}{3} = \frac{2}{3}h$ metres.

Volume of the air inside the building = Volume of air inside the dome + Volume of the air inside the cylinder = $\frac{2}{3}\pi r^3 + \pi r^2 H$, where H is the height of the cylindrical portion

$$= \frac{2}{3}\pi \frac{h}{3}^3 + \pi \frac{h}{3}^2 \frac{2}{3}h = \frac{8}{81}\pi h^3 \text{ cu. metres}$$

Volume of the air inside the building is $67\frac{1}{21}\text{ m}^3$. Therefore, $\frac{8}{81}\pi h^3 = \frac{1408}{21}$. This gives $h = 6$ m.

EXERCISE 12.4

1. A solid metallic hemisphere of radius 8 cm is melted and recasted into a right circular cone of base radius 6 cm. Determine the height of the cone.
2. A rectangular water tank of base 11 m \times 6 m contains water upto a height of 5 m. If the water in the tank is transferred to a cylindrical tank of radius 3.5 m, find the height of the water level in the tank.
3. How many cubic centimetres of iron is required to construct an open box whose external dimensions are 36 cm, 25 cm and 16.5 cm provided the thickness of the iron is 1.5 cm. If one cubic cm of iron weighs 7.5 g, find the weight of the box.
4. The barrel of a fountain pen, cylindrical in shape, is 7 cm long and 5 mm in diameter. A full barrel of ink in the pen is used up on writing 3300 words on an average. How many words can be written in a bottle of ink containing one fifth of a litre?
5. Water flows at the rate of 10m/minute through a cylindrical pipe 5 mm in diameter. How long would it take to fill a conical vessel whose diameter at the base is 40 cm and depth 24 cm?
6. A heap of rice is in the form of a cone of diameter 9 m and height 3.5 m. Find the volume of the rice. How much canvas cloth is required to just cover the heap?
7. A factory manufactures 120000 pencils daily. The pencils are cylindrical in shape each of length 25 cm and circumference of base as 1.5 cm. Determine the cost of colouring the curved surfaces of the pencils manufactured in one day at Rs 0.05 per dm^2 .

8. Water is flowing at the rate of 15 km/h through a pipe of diameter 14 cm into a cuboidal pond which is 50 m long and 44 m wide. In what time will the level of water in pond rise by 21 cm?
9. A solid iron cuboidal block of dimensions 4.4 m × 2.6 m × 1 m is recast into a hollow cylindrical pipe of internal radius 30 cm and thickness 5 cm. Find the length of the pipe.
10. 500 persons are taking a dip into a cuboidal pond which is 80 m long and 50 m broad. What is the rise of water level in the pond, if the average displacement of the water by a person is 0.04m³?
11. 16 glass spheres each of radius 2 cm are packed into a cuboidal box of internal dimensions 16 cm × 8 cm × 8 cm and then the box is filled with water. Find the volume of water filled in the box.
12. A milk container of height 16 cm is made of metal sheet in the form of a frustum of a cone with radii of its lower and upper ends as 8 cm and 20 cm respectively. Find the cost of milk at the rate of Rs. 22 per litre which the container can hold.
13. A cylindrical bucket of height 32 cm and base radius 18 cm is filled with sand. This bucket is emptied on the ground and a conical heap of sand is formed. If the height of the conical heap is 24 cm, find the radius and slant height of the heap.
14. A rocket is in the form of a right circular cylinder closed at the lower end and surmounted by a cone with the same radius as that of the cylinder. The diameter and height of the cylinder are 6 cm and 12 cm, respectively. If the the slant height of the conical portion is 5 cm, find the total surface area and volume of the rocket [Use $\pi = 3.14$].
15. A building is in the form of a cylinder surmounted by a hemispherical vaulted dome and contains $41\frac{19}{21}$ m³ of air. If the internal diameter of dome is equal to its total height above the floor, find the height of the building?
16. A hemispherical bowl of internal radius 9 cm is full of liquid. The liquid is to be filled into cylindrical shaped bottles each of radius 1.5 cm and height 4 cm. How many bottles are needed to empty the bowl?
17. A solid right circular cone of height 120 cm and radius 60 cm is placed in a right circular cylinder full of water of height 180 cm such that it touches the bottom. Find the volume of water left in the cylinder, if the radius of the cylinder is equal to the radius of the cone.

- 18.** Water flows through a cylindrical pipe, whose inner radius is 1 cm, at the rate of 80 cm/sec in an empty cylindrical tank, the radius of whose base is 40 cm. What is the rise of water level in tank in half an hour?
- 19.** The rain water from a roof of dimensions $22\text{ m} \times 20\text{ m}$ drains into a cylindrical vessel having diameter of base 2 m and height 3.5 m. If the rain water collected from the roof just fill the cylindrical vessel, then find the rainfall in cm.
- 20.** A pen stand made of wood is in the shape of a cuboid with four conical depressions and a cubical depression to hold the pens and pins, respectively. The dimension of the cuboid are 10 cm, 5 cm and 4 cm. The radius of each of the conical depressions is 0.5 cm and the depth is 2.1 cm. The edge of the cubical depression is 3 cm. Find the volume of the wood in the entire stand.

STATISTICS AND PROBABILITY

(A) Main Concepts and Results

Statistics

Measures of Central Tendency

(a) Mean of Grouped Data

- (i) To find the mean of grouped data, it is assumed that the frequency of each class interval is centred around its mid-point.
- (ii) **Direct Method**

$$\text{Mean } (\bar{x}) = \frac{f_i x_i}{f_i},$$

where the x_i (class mark) is the mid-point of the i th class interval and f_i is the corresponding frequency.

- (iii) **Assumed Mean Method**

$$\text{Mean } (\bar{x}) = a + \frac{f_i d_i}{f_i},$$

a is the *assumed mean* and $d_i = x_i - a$ are the deviations of x_i from a for each i .

(iv) Step-deviation Method

$$\text{Mean } (\bar{x}) = a + h \frac{f_i u_i}{f_i},$$

where a is the assumed mean, h is the class size and $u_i = \frac{x_i - a}{h}$.

- (v) If the class sizes are unequal, the formula in (iv) can still be applied by taking h to be a suitable divisor of all the d_i 's.

(b) Mode of Grouped Data

- (i) In a grouped frequency distribution, it is not possible to determine the mode by looking at the frequencies. To find the mode of grouped data, locate the class with the maximum frequency. This class is known as the *modal class*. The mode of the data is a value inside the modal class.
- (ii) Mode of the grouped data can be calculated by using the formula

$$\text{Mode} = l + \frac{f_1 - f_0}{2f_1 - f_0 - f_2} \times h,$$

where l is the lower limit of the modal class, h is the size of the class, f_1 is frequency of the modal class and f_0 and f_2 are the frequencies of the classes preceding and succeeding the modal class, respectively.

(c) Median of Grouped Data

- (i) Cumulative frequency table – the less than type and the more than type of the grouped frequency distribution.
- (ii) If n is the total number of observations, locate the class whose cumulative frequency is greater than (and nearest to) $\frac{n}{2}$. This class is called the *median class*.
- (iii) Median of the grouped data can be calculated by using the formula :

$$\text{Median} = l + \left(\frac{\frac{n}{2} - \text{cf}}{f} \right) h,$$

where l is the lower limit of the median class, n is the number of observations, h is the class size, cf is the cumulative frequency of the class preceding the median class and f is the frequency of the median class.

(d) Graphical Representation of Cumulative Frequency Distribution (Ogive)

– Less than type and more than type.

- (i) To find median from the graph of cumulative frequency distribution (less than type) of a grouped data.
- (ii) To find median from the graphs of cumulative frequency distributions (of less than type and more than type) as the abscissa of the point of intersection of the graphs.

Probability

- Random experiment, outcome of an experiment, event, elementary events.
- Equally likely outcomes.
- The theoretical (or classical) probability of an event E [denoted by $P(E)$] is given by

$$P(E) = \frac{\text{Number of outcomes favourable to } E}{\text{Number of all possible outcomes of the experiment}}$$

where the outcomes of the experiment are *equally likely*.

- The probability of an event can be any number between 0 and 1. It can also be 0 or 1 in some special cases.
- The sum of the probabilities of all the elementary events of an experiment is 1.
- For an event E , $P(E) + P(\bar{E}) = 1$,
where \bar{E} is the event 'not E '. \bar{E} is called the complement of the event E .
- Impossible event, sure or a certain event

(B) Multiple Choice Questions

Choose the correct answer from the given four options:

Sample Question 1 : Construction of a cumulative frequency table is useful in determining the

- | | |
|----------|----------------------------------|
| (A) mean | (B) median |
| (C) mode | (D) all the above three measures |

Solution : Answer (B)

Sample Question 2 : In the following distribution :

Monthly income range (in Rs)	Number of families
Income more than Rs 10000	100
Income more than Rs 13000	85
Income more than Rs 16000	69
Income more than Rs 19000	50
Income more than Rs 22000	33
Income more than Rs 25000	15

the number of families having income range (in Rs) 16000 – 19000 is

- (A) 15 (B) 16 (C) 17 (D) 19

Solution : Answer (D)

Sample Question 3 : Consider the following frequency distribution of the heights of 60 students of a class :

Height (in cm)	Number of students
150-155	15
155-160	13
160-165	10
165-170	8
170-175	9
175-180	5

The sum of the lower limit of the modal class and upper limit of the median class is

- (A) 310 (B) 315 (C) 320 (D) 330

Solution : Answer (B)

Sample Question 4 : Which of the the following can be the probability of an event?

- (A) -0.04 (B) 1.004 (C) $\frac{18}{23}$ (D) $\frac{8}{7}$

Solution : Answer (C)

Sample Question 5 : A card is selected at random from a well shuffled deck of 52 playing cards. The probability of its being a face card is

- (A) $\frac{3}{13}$ (B) $\frac{4}{13}$ (C) $\frac{6}{13}$ (D) $\frac{9}{13}$

Solution : Answer (A)

Sample Question 6 : A bag contains 3 red balls, 5 white balls and 7 black balls. What is the probability that a ball drawn from the bag at random will be neither red nor black?

- (A) $\frac{1}{5}$ (B) $\frac{1}{3}$ (C) $\frac{7}{15}$ (D) $\frac{8}{15}$

Solution : Answer (B)

EXERCISE 13.1

Choose the correct answer from the given four options:

1. In the formula

$$\bar{x} = a + \frac{f_i d_i}{f_i},$$

for finding the mean of grouped data d_i 's are deviations from a of

- (A) lower limits of the classes
 - (B) upper limits of the classes
 - (C) mid points of the classes
 - (D) frequencies of the class marks
2. While computing mean of grouped data, we assume that the frequencies are
- (A) evenly distributed over all the classes
 - (B) centred at the classmarks of the classes
 - (C) centred at the upper limits of the classes
 - (D) centred at the lower limits of the classes
3. If x_i 's are the mid points of the class intervals of grouped data, f_i 's are the corresponding frequencies and \bar{x} is the mean, then $(\sum f_i x_i - \bar{x})$ is equal to
- (A) 0 (B) -1 (C) 1 (D) 2

4. In the formula $\bar{x} = a + h \frac{f_i u_i}{f_i}$, for finding the mean of grouped frequency distribution, $u_i =$

- (A) $\frac{x_i + a}{h}$ (B) $h(x_i - a)$ (C) $\frac{x_i - a}{h}$ (D) $\frac{a - x_i}{h}$

5. The abscissa of the point of intersection of the less than type and of the more than type cumulative frequency curves of a grouped data gives its
 (A) mean (B) median
 (C) mode (D) all the three above
6. For the following distribution :

Class	0-5	5-10	10-15	15-20	20-25
Frequency	10	15	12	20	9

the sum of lower limits of the median class and modal class is

- (A) 15 (B) 25 (C) 30 (D) 35
7. Consider the following frequency distribution :

Class	0-5	6-11	12-17	18-23	24-29
Frequency	13	10	15	8	11

The upper limit of the median class is

- (A) 17 (B) 17.5 (C) 18 (D) 18.5
8. For the following distribution :

Marks	Number of students
Below 10	3
Below 20	12
Below 30	27
Below 40	57
Below 50	75
Below 60	80

the modal class is

- (A) 10-20 (B) 20-30 (C) 30-40 (D) 50-60
9. Consider the data :

Class	65-85	85-105	105-125	125-145	145-165	165-185	185-205
Frequency	4	5	13	20	14	7	4

The difference of the upper limit of the median class and the lower limit of the modal class is

- (A) 0 (B) 19 (C) 20 (D) 38

10. The times, in seconds, taken by 150 athletes to run a 110 m hurdle race are tabulated below :

Class	13.8-14	14-14.2	14.2-14.4	14.4-14.6	14.6-14.8	14.8-15
Frequency	2	4	5	71	48	20

The number of athletes who completed the race in less than 14.6 seconds is :

- (A) 11 (B) 71 (C) 82 (D) 130

11. Consider the following distribution :

Marks obtained	Number of students
More than or equal to 0	63
More than or equal to 10	58
More than or equal to 20	55
More than or equal to 30	51
More than or equal to 40	48
More than or equal to 50	42

the frequency of the class 30-40 is

- (A) 3 (B) 4 (C) 48 (D) 51

12. If an event cannot occur, then its probability is

- (A) 1 (B) $\frac{3}{4}$ (C) $\frac{1}{2}$ (D) 0

13. Which of the following cannot be the probability of an event?

- (A) $\frac{1}{3}$ (B) 0.1 (C) 3% (D) $\frac{17}{16}$

14. An event is very unlikely to happen. Its probability is closest to

- (A) 0.0001 (B) 0.001 (C) 0.01 (D) 0.1

15. If the probability of an event is p , the probability of its complementary event will be

- (A) $p - 1$ (B) p (C) $1 - p$ (D) $1 - \frac{1}{p}$

- 16.** The probability expressed as a percentage of a particular occurrence can never be
(A) less than 100 (B) less than 0
(C) greater than 1 (D) anything but a whole number
- 17.** If $P(A)$ denotes the probability of an event A , then
(A) $P(A) < 0$ (B) $P(A) > 1$ (C) $0 \leq P(A) \leq 1$ (D) $-1 \leq P(A) \leq 1$
- 18.** A card is selected from a deck of 52 cards. The probability of its being a red face card is
(A) $\frac{3}{26}$ (B) $\frac{3}{13}$ (C) $\frac{2}{13}$ (D) $\frac{1}{2}$
- 19.** The probability that a non leap year selected at random will contain 53 sundays is
(A) $\frac{1}{7}$ (B) $\frac{2}{7}$ (C) $\frac{3}{7}$ (D) $\frac{5}{7}$
- 20.** When a die is thrown, the probability of getting an odd number less than 3 is
(A) $\frac{1}{6}$ (B) $\frac{1}{3}$ (C) $\frac{1}{2}$ (D) 0
- 21.** A card is drawn from a deck of 52 cards. The event E is that card is not an ace of hearts. The number of outcomes favourable to E is
(A) 4 (B) 13 (C) 48 (D) 51
- 22.** The probability of getting a bad egg in a lot of 400 is 0.035. The number of bad eggs in the lot is
(A) 7 (B) 14 (C) 21 (D) 28
- 23.** A girl calculates that the probability of her winning the first prize in a lottery is 0.08. If 6000 tickets are sold, how many tickets has she bought?
(A) 40 (B) 240 (C) 480 (D) 750
- 24.** One ticket is drawn at random from a bag containing tickets numbered 1 to 40. The probability that the selected ticket has a number which is a multiple of 5 is
(A) $\frac{1}{5}$ (B) $\frac{3}{5}$ (C) $\frac{4}{5}$ (D) $\frac{1}{3}$
- 25.** Someone is asked to take a number from 1 to 100. The probability that it is a prime is
(A) $\frac{1}{5}$ (B) $\frac{6}{25}$ (C) $\frac{1}{4}$ (D) $\frac{13}{50}$

26. A school has five houses A, B, C, D and E. A class has 23 students, 4 from house A, 8 from house B, 5 from house C, 2 from house D and rest from house E. A single student is selected at random to be the class monitor. The probability that the selected student is not from A, B and C is

- (A) $\frac{4}{23}$ (B) $\frac{6}{23}$ (C) $\frac{8}{23}$ (D) $\frac{17}{23}$

(C) Short Answer Questions with Reasoning

Sample Question 1: The mean of ungrouped data and the mean calculated when the same data is grouped are always the same. Do you agree with this statement? Give reason for your answer.

Solution : The statement is not true. The reason is that when we calculated mean of a grouped data, it is assumed that frequency of each class is centred at the mid-point of the class. Because of this, two values of the mean, namely, those from ungrouped and grouped data are rarely the same.

Sample Question 2 : Is it correct to say that an ogive is a graphical representation of a frequency distribution? Give reason.

Solution : Graphical representation of a frequency distribution may not be an ogive. It may be a histogram. An ogive is a graphical representation of cumulative frequency distribution.

Sample Question 3 : In any situation that has only two possible outcomes, each outcome will have probability $\frac{1}{2}$. True or false? Why?

Solution : False, because the probability of each outcome will be $\frac{1}{2}$ only when the two outcomes are equally likely otherwise not.

EXERCISE 13.2

- The median of an ungrouped data and the median calculated when the same data is grouped are always the same. Do you think that this is a correct statement? Give reason.
- In calculating the mean of grouped data, grouped in classes of equal width, we may use the formula

$$\bar{x} = a + \frac{f_i d_i}{f_i}$$

where a is the assumed mean. a must be one of the mid-points of the classes. Is the last statement correct? Justify your answer.

3. Is it true to say that the mean, mode and median of grouped data will always be different? Justify your answer.
4. Will the median class and modal class of grouped data always be different? Justify your answer.
5. In a family having three children, there may be no girl, one girl, two girls or three girls. So, the probability of each is $\frac{1}{4}$. Is this correct? Justify your answer.
6. A game consists of spinning an arrow which comes to rest pointing at one of the regions (1, 2 or 3) (Fig. 13.1). Are the outcomes 1, 2 and 3 equally likely to occur? Give reasons.

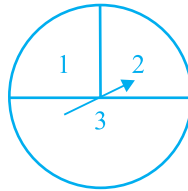

Fig. 13.1

7. Apoorv throws two dice once and computes the product of the numbers appearing on the dice. Peehu throws one die and squares the number that appears on it. Who has the better chance of getting the number 36? Why?
8. When we toss a coin, there are two possible outcomes - Head or Tail. Therefore, the probability of each outcome is $\frac{1}{2}$. Justify your answer.
9. A student says that if you throw a die, it will show up 1 or not 1. Therefore, the probability of getting 1 and the probability of getting 'not 1' each is equal to $\frac{1}{2}$. Is this correct? Give reasons.
10. I toss three coins together. The possible outcomes are no heads, 1 head, 2 heads and 3 heads. So, I say that probability of no heads is $\frac{1}{4}$. What is wrong with this conclusion?
11. If you toss a coin 6 times and it comes down heads on each occasion. Can you say that the probability of getting a head is 1? Give reasons.

12. Sushma tosses a coin 3 times and gets tail each time. Do you think that the outcome of next toss will be a tail? Give reasons.
13. If I toss a coin 3 times and get head each time, should I expect a tail to have a higher chance in the 4th toss? Give reason in support of your answer.
14. A bag contains slips numbered from 1 to 100. If Fatima chooses a slip at random from the bag, it will either be an odd number or an even number. Since this situation has only two possible outcomes, so, the probability of each is $\frac{1}{2}$. Justify.

(D) Short Answer Questions

Sample Question 1 : Construct the cumulative frequency distribution of the following distribution :

Class	12.5-17.5	17.5-22.5	22.5-27.5	27.5-32.5	32.5-37.5
Frequency	2	22	19	14	13

Solution : The required cumulative frequency distribution of the given distribution is given below :

Class	Frequency	Cumulative frequency
12.5-17.5	2	2
17.5-22.5	22	24
22.5-27.5	19	43
27.5-32.5	14	57
32.5-37.5	13	70

Sample Question 2 : Daily wages of 110 workers, obtained in a survey, are tabulated below :

Daily wages (in Rs)	Number of workers
100-120	10
120-140	15
140-160	20
160-180	22
180-200	18
200-220	12
220-240	13

Compute the mean daily wages of these workers.

Solution : We first find the classmark, x_i , of each class and then proceed as follows:

Daily wages (in Rs) Classes	Class marks (x_i)	Number of workers (f_i)	$f_i x_i$
100-120	110	10	1100
120-140	130	15	1950
140-160	150	20	3000
160-180	170	22	3740
180-200	190	18	3420
200-220	210	12	2520
220-240	230	13	2990

$$f_i = 110,$$

$$f_i x_i = 18720$$

$$\text{Therefore, Mean} = \bar{x} = \frac{f_i x_i}{f_i} = \frac{18720}{110} = 170.20$$

Hence, the mean daily wages of the workers is Rs 170.20.

Note : Mean daily wages can also be calculated by the assumed mean method or step deviation method.

Sample Question 3 : The percentage of marks obtained by 100 students in an examination are given below:

Marks	30-35	35-40	40-45	45-50	50-55	55-60	60-65
Frequency	14	16	18	23	18	8	3

Determine the median percentage of marks.

Solution :

Marks (Class)	Number of Students (Frequency)	Cumulative frequency
30-35	14	14
35-40	16	30
40-45	18	48
45-50	23	71 ← Median class
50-55	18	89
55-60	8	97
60-65	3	100

Here, $n = 100$.

Therefore, $\frac{n}{2} = 50$, This observation lies in the class 45-50.

l (the lower limit of the median class) = 45

cf (the cumulative frequency of the class preceding the median class) = 48

f (the frequency of the median class) = 23

h (the class size) = 5

$$\begin{aligned} \text{Median} &= l + \left(\frac{\frac{n}{2} - \text{cf}}{f} \right) h \\ &= 45 + \left(\frac{50 - 48}{23} \right) \times 5 \\ &= 45 + \frac{10}{23} = 45.4 \end{aligned}$$

So, the median percentage of marks is 45.4.

Sample Question 4 : The frequency distribution table of agricultural holdings in a village is given below :

Area of land (in hectares)	1-3	3-5	5-7	7-9	9-11	11-13
Number of families	20	45	80	55	40	12

Find the modal agricultural holdings of the village.

Solution : Here the maximum class frequency is 80, and the class corresponding to this frequency is 5-7.

So, the modal class is 5-7.

l (lower limit of modal class) = 5

f_i (frequency of the modal class) = 80

f_0 (frequency of the class preceding the modal class) = 45
 f_2 (frequency of the class succeeding the modal class) = 55
 h (class size) = 2

$$\begin{aligned}
 \text{Mode} &= l + \frac{f_1 - f_0}{2f_1 - f_0 - f_2} \times h \\
 &= 5 + \frac{80 - 45}{2(80) - 45 - 55} \times 2 \\
 &= 5 + \frac{35}{60} \times 2 = 5 + \frac{35}{30} \\
 &= 5 + 1.2 = 6.2
 \end{aligned}$$

Hence, the modal agricultural holdings of the village is 6.2 hectares.

EXERCISE 13.3

1. Find the mean of the distribution :

Class	1-3	3-5	5-7	7-10
Frequency	9	22	27	17

2. Calculate the mean of the scores of 20 students in a mathematics test :

Marks	10-20	20-30	30-40	40-50	50-60
Number of students	2	4	7	6	1

3. Calculate the mean of the following data :

Class	4 - 7	8 - 11	12 - 15	16 - 19
Frequency	5	4	9	10

4. The following table gives the number of pages written by Sarika for completing her own book for 30 days :

Number of pages written per day	16-18	19-21	22-24	25-27	28-30
Number of days	1	3	4	9	13

Find the mean number of pages written per day.

5. The daily income of a sample of 50 employees are tabulated as follows :

Income (in Rs)	1-200	201-400	401-600	601-800
Number of employees	14	15	14	7

Find the mean daily income of employees.

6. An aircraft has 120 passenger seats. The number of seats occupied during 100 flights is given in the following table :

Number of seats	100-104	104-108	108-112	112-116	116-120
Frequency	15	20	32	18	15

Determine the mean number of seats occupied over the flights.

7. The weights (in kg) of 50 wrestlers are recorded in the following table :

Weight (in kg)	100-110	110-120	120-130	130-140	140-150
Number of wrestlers	4	14	21	8	3

Find the mean weight of the wrestlers.

8. The mileage (km per litre) of 50 cars of the same model was tested by a manufacturer and details are tabulated as given below :

Mileage (km/l)	10-12	12-14	14-16	16-18
Number of cars	7	12	18	13

Find the mean mileage.

The manufacturer claimed that the mileage of the model was 16 km/litre. Do you agree with this claim?

9. The following is the distribution of weights (in kg) of 40 persons :

Weight (in kg)	40-45	45-50	50-55	55-60	60-65	65-70	70-75	75-80
Number of persons	4	4	13	5	6	5	2	1

Construct a cumulative frequency distribution (of the less than type) table for the data above.

10. The following table shows the cumulative frequency distribution of marks of 800 students in an examination:

Marks	Number of students
Below 10	10
Below 20	50
Below 30	130
Below 40	270
Below 50	440
Below 60	570
Below 70	670
Below 80	740
Below 90	780
Below 100	800

Construct a frequency distribution table for the data above.

11. Form the frequency distribution table from the following data :

Marks (out of 90)	Number of candidates
More than or equal to 80	4
More than or equal to 70	6
More than or equal to 60	11
More than or equal to 50	17
More than or equal to 40	23
More than or equal to 30	27
More than or equal to 20	30
More than or equal to 10	32
More than or equal to 0	34

12. Find the unknown entries a, b, c, d, e, f in the following distribution of heights of students in a class :

Height (in cm)	Frequency	Cumulative frequency
150-155	12	a
155-160	b	25
160-165	10	c
165-170	d	43
170-175	e	48
175-180	2	f
Total	50	

13. The following are the ages of 300 patients getting medical treatment in a hospital on a particular day :

Age (in years)	10-20	20-30	30-40	40-50	50-60	60-70
Number of patients	60	42	55	70	53	20

Form:

- (i) Less than type cumulative frequency distribution.
- (ii) More than type cumulative frequency distribution.

14. Given below is a cumulative frequency distribution showing the marks secured by 50 students of a class :

Marks	Below 20	Below 40	Below 60	Below 80	Below 100
Number of students	17	22	29	37	50

Form the frequency distribution table for the data.

15. Weekly income of 600 families is tabulated below :

Weekly income (in Rs)	Number of families
0-1000	250
1000-2000	190
2000-3000	100
3000-4000	40
4000-5000	15
5000-6000	5
Total	600

Compute the median income.

16. The maximum bowling speeds, in km per hour, of 33 players at a cricket coaching centre are given as follows :

Speed (km/h)	85-100	100-115	115-130	130-145
Number of players	11	9	8	5

Calculate the median bowling speed.

17. The monthly income of 100 families are given as below :

Income (in Rs)	Number of families
0-5000	8
5000-10000	26
10000-15000	41
15000-20000	16
20000-25000	3
25000-30000	3
30000-35000	2
35000-40000	1

Calculate the modal income.

18. The weight of coffee in 70 packets are shown in the following table :

Weight (in g)	Number of packets
200-201	12
201-202	26
202-203	20
203-204	9
204-205	2
205-206	1

Determine the modal weight.

19. Two dice are thrown at the same time. Find the probability of getting

- (i) same number on both dice.
- (ii) different numbers on both dice.

20. Two dice are thrown simultaneously. What is the probability that the sum of the numbers appearing on the dice is

- (i) 7?
- (ii) a prime number?
- (iii) 1?

- 21.** Two dice are thrown together. Find the probability that the product of the numbers on the top of the dice is
(i) 6 (ii) 12 (iii) 7
- 22.** Two dice are thrown at the same time and the product of numbers appearing on them is noted. Find the probability that the product is less than 9.
- 23.** Two dice are numbered 1, 2, 3, 4, 5, 6 and 1, 1, 2, 2, 3, 3, respectively. They are thrown and the sum of the numbers on them is noted. Find the probability of getting each sum from 2 to 9 separately.
- 24.** A coin is tossed two times. Find the probability of getting at most one head.
- 25.** A coin is tossed 3 times. List the possible outcomes. Find the probability of getting
(i) all heads (ii) at least 2 heads
- 26.** Two dice are thrown at the same time. Determine the probability that the difference of the numbers on the two dice is 2.
- 27.** A bag contains 10 red, 5 blue and 7 green balls. A ball is drawn at random. Find the probability of this ball being a
(i) red ball (ii) green ball (iii) not a blue ball
- 28.** The king, queen and jack of clubs are removed from a deck of 52 playing cards and then well shuffled. Now one card is drawn at random from the remaining cards. Determine the probability that the card is
(i) a heart (ii) a king
- 29.** Refer to Q.28. What is the probability that the card is
(i) a club (ii) 10 of hearts
- 30.** All the jacks, queens and kings are removed from a deck of 52 playing cards. The remaining cards are well shuffled and then one card is drawn at random. Giving ace a value 1 similar value for other cards, find the probability that the card has a value
(i) 7 (ii) greater than 7 (iii) less than 7
- 31.** An integer is chosen between 0 and 100. What is the probability that it is
(i) divisible by 7? (ii) not divisible by 7?
- 32.** Cards with numbers 2 to 101 are placed in a box. A card is selected at random. Find the probability that the card has
(i) an even number (ii) a square number

- 33.** A letter of English alphabets is chosen at random. Determine the probability that the letter is a consonant.
- 34.** There are 1000 sealed envelopes in a box, 10 of them contain a cash prize of Rs 100 each, 100 of them contain a cash prize of Rs 50 each and 200 of them contain a cash prize of Rs 10 each and rest do not contain any cash prize. If they are well shuffled and an envelope is picked up out, what is the probability that it contains no cash prize?
- 35.** Box A contains 25 slips of which 19 are marked Re 1 and other are marked Rs 5 each. Box B contains 50 slips of which 45 are marked Re 1 each and others are marked Rs 13 each. Slips of both boxes are poured into a third box and resuffled. A slip is drawn at random. What is the probability that it is marked other than Re 1?
- 36.** A carton of 24 bulbs contain 6 defective bulbs. One bulb is drawn at random. What is the probability that the bulb is not defective? If the bulb selected is defective and it is not replaced and a second bulb is selected at random from the rest, what is the probability that the second bulb is defective?
- 37.** A child's game has 8 triangles of which 3 are blue and rest are red, and 10 squares of which 6 are blue and rest are red. One piece is lost at random. Find the probability that it is a
- (i) triangle
 - (ii) square
 - (iii) square of blue colour
 - (iv) triangle of red colour
- 38.** In a game, the entry fee is Rs 5. The game consists of a tossing a coin 3 times. If one or two heads show, Sweta gets her entry fee back. If she throws 3 heads, she receives double the entry fees. Otherwise she will lose. For tossing a coin three times, find the probability that she
- (i) loses the entry fee.
 - (ii) gets double entry fee.
 - (iii) just gets her entry fee.
- 39.** A die has its six faces marked 0, 1, 1, 1, 6, 6. Two such dice are thrown together and the total score is recorded.
- (i) How many different scores are possible?
 - (ii) What is the probability of getting a total of 7?
- 40.** A lot consists of 48 mobile phones of which 42 are good, 3 have only minor defects and 3 have major defects. Varnika will buy a phone if it is good but the trader will only buy a mobile if it has no major defect. One phone is selected at random from the lot. What is the probability that it is

- (i) acceptable to Varnika?
 (ii) acceptable to the trader?
41. A bag contains 24 balls of which x are red, $2x$ are white and $3x$ are blue. A ball is selected at random. What is the probability that it is
 (i) not red? (ii) white?
42. At a fete, cards bearing numbers 1 to 1000, one number on one card, are put in a box. Each player selects one card at random and that card is not replaced. If the selected card has a perfect square greater than 500, the player wins a prize. What is the probability that
 (i) the first player wins a prize?
 (ii) the second player wins a prize, if the first has won?

(E) Long Answer Questions

Sample Question 1: The following is the cumulative frequency distribution (of less than type) of 1000 persons each of age 20 years and above. Determine the mean age.

Age below (in years)	30	40	50	60	70	80
Number of persons	100	220	350	750	950	1000

Solution : First, we make the frequency distribution of the given data and then proceed to calculate mean by computing class marks (x_i), u_i 's and $f_i u_i$'s as follows :





Class	Frequency (f_i)	Class mark (x_i)	$u_i = \frac{x_i - 45}{10}$	$f_i u_i$
20-30	100	25	-2	-200
30-40	120	35	-1	-120
40-50	130	45	0	0
50-60	400	55	1	400
60-70	200	65	2	400
70-80	50	75	3	150
	$f_i = 1000$			$f_i u_i = 630$











SCHOOL OF EDUCATORS





You will get Pre- Board Papers PDF, Word file, PPT, Lesson Plan, Worksheet, practical tips and Viva questions , reference books , smart content , curriculum , syllabus , marking scheme , toppers answer scripts , revised exam pattern , revised syllabus , Blue Print etc. here **.Join Your Subject WhatsApp Group.**

Kindergarten
 [Click to Join](#)

Class 1  [Click to Join](#) **Class 2**  [Click to Join](#) **Class 3**  [Click to Join](#) **Class 4**  [Click to Join](#)





Class 5  [Click to Join](#) **Class 6**  [Click to Join](#) **Class 7**  [Click to Join](#) **Class 8**  [Click to Join](#)

Class 9  [Click to Join](#) **Class 10**  [Click to Join](#) **Class 11 (Science)**  [Click to Join](#) **Class 11 (Commerce)**  [Click to Join](#)

Class 11 (Humanities)  [Click to Join](#) **Class 12 (Science)**  [Click to Join](#) **Class 12 (Commerce)**  [Click to Join](#) **Class 12 (Humanities)**  [Click to Join](#)





















Subject Wise Groups Secondary and Senior Secondary

Secondary Groups (IX & X)

SST  [Click to Join](#) **Mathematics**  [Click to Join](#) **Science**  [Click to Join](#) **English**  [Click to Join](#)

Hindi  [Click to Join](#) **Information Technology**  [Click to Join](#)

Senior Secondary Groups (XI & XII)

Physics  Click to Join	Chemistry  Click to Join	English  Click to Join	Mathematics  Click to Join
Biology  Click to Join	Accountancy  Click to Join	Economics  Click to Join	BST  Click to Join
History  Click to Join	Geography  Click to Join	Sociology  Click to Join	Hindi Elective  Click to Join
Hindi Core  Click to Join	Home Science  Click to Join	Sanskrit  Click to Join	Psychology  Click to Join
Political Science  Click to Join	Painting  Click to Join	Vocal Music  Click to Join	Comp. Science  Click to Join
IP  Click to Join	Physical Education  Click to Join	App. Mathematics  Click to Join	IIT /NEET  Click to Join

Rules & Regulations of the Group

1. No introduction
2. No Good Morning/Any wish type message
- 3.No personal Chats & Messages
4. No Spam
5. You can also ask your difficulties here.

Just get learning resources & post learning resources.
Helpline number only WhatsApp: +91-95208-77777

Why Artham Resource Material?

Resource materials for teachers and students are essential tools for effective teaching and learning. They provide valuable information, guidance, and support to both teachers and students, making the teaching and learning process more efficient and productive.

For teachers, Artham resource materials include lesson plans, instructional guides, assessment tools, professional development materials, and teaching aids. These materials are well researched and created according to 2023-24 NEP and NCERT guidelines.

For students, resource materials can include textbooks, study guides, homework assignments, reference books, online learning platforms, and educational videos. These materials can be obtained from school libraries, educational publishers, online resources, and teachers.

Both teachers and students can also benefit from Artham educational resources which are free and openly licensed educational materials that can be used and shared for teaching and learning. Artham resource material include textbooks, courses, lesson plans, and multimedia resources that are available online.

In summary, resource materials are critical components of effective teaching and learning. They provide a wealth of information and support that can enhance the quality of education and help students achieve academic success.

Teachers and students can also purchase these resources from the links provided with every resource.

JOIN TELEGRAM GROUP/CHANNELS FOR CLASS WISE HIGH QUALITY RESOURCE MATERIAL

SOE CBSE Groups

- [Click to Join CBSE Group...All classes](#)
- [Click to Join SOE CBSE Kindergarten Group](#)
- [Click to Join SOE CBSE Class 1 Group](#)
- [Click to Join SOE CBSE Class 2 Group](#)
- [Click to Join SOE CBSE Class 3 Group](#)
- [Click to Join SOE CBSE Class 4 Group](#)
- [Click to Join SOE CBSE Class 5 Group](#)
- [Click to Join SOE CBSE Class 6 Group](#)
- [Click to Join SOE CBSE Class 7 Group](#)
- [Click to Join SOE CBSE Class 8 Group](#)
- [Click to Join SOE CBSE Class 9 Group](#)
- [Click to Join SOE CBSE Class 10 Group](#)
- [Click to Join SOE CBSE Class 11 \(Science\) Group](#)
- [Click to Join SOE CBSE Class 11 \(Commerce\) Group](#)
- [Click to Join SOE CBSE Class 11 \(Humanities\) Group](#)
- [Click to Join SOE CBSE Class 12 \(Science\) Group](#)
- [Click to Join SOE CBSE Class 12\(Commerce\) Group](#)

- [Click to Join SOE CBSE Class 12 \(Humanities\) Group](#)
- [Click to Join SOE JEE/NEET Group](#)
- [Click to Join SOE CUET Group](#)
- [Click to Join SOE NDA, OLYMPIAD, NTSE Group](#)
- [Click to Join SOE School Principal Professional Development Group](#)
- [Click to Join SOE School Teacher Professional Development Group](#)

SOE ICSE Groups

- [Click to Join SOE ICSE Kindergarten Group](#)
- [Click to Join SOE ICSE Class 1 Group](#)
- [Click to Join SOE ICSE Class 2 Group](#)
- [Click to Join SOE ICSE Class 3 Group](#)
- [Click to Join SOE ICSE Class 4 Group](#)
- [Click to Join SOE ICSE Class 5 Group](#)
- [Click to Join SOE ICSE Class 6 Group](#)
- [Click to Join SOE ICSE Class 7 Group](#)
- [Click to Join SOE ICSE Class 8 Group](#)
- [Click to Join SOE ICSE Class 9 Group](#)
- [Click to Join SOE ICSE Class 10 Group](#)
- [Click to Join SOE ICSE Class 11 \(Science\) Group](#)
- [Click to Join SOE ICSE Class 11 \(Commerce\) Group](#)
- [Click to Join SOE ICSE Class 11 \(Humanities\) Group](#)
- [Click to Join SOE ICSE Class 12 \(Science\) Group](#)
- [Click to Join SOE ICSE Class 12\(Commerce\) Group](#)
- [Click to Join SOE ICSE Class 12 \(Humanities\) Group](#)
- [Click to Join SOE JEE/NEET Group](#)
- [Click to Join SOE CUET Group](#)
- [Click to Join SOE NDA, OLYMPIAD, NTSE Group](#)
- [Click to Join SOE School Principal Professional Development Group](#)
- [Click to Join SOE School Teacher Professional Development Group](#)

Nageen CBSE Channels

- [Click to Join Nageen CBSE Kindergarten Channel](#)
- [Click to Join Nageen CBSE Class 1 Channel](#)
- [Click to Join Nageen CBSE Class 2 Channel](#)
- [Click to Join Nageen CBSE Class 3 Channel](#)
- [Click to Join Nageen CBSE Class 4 Channel](#)
- [Click to Join Nageen CBSE Class 5 Channel](#)
- [Click to Join Nageen CBSE Class 6 Channel](#)
- [Click to Join Nageen CBSE Class 7 Channel](#)
- [Click to Join Nageen CBSE Class 8 Channel](#)
- [Click to Join Nageen CBSE Class 9 Channel](#)
- [Click to Join Nageen CBSE Class 10 Channel](#)
- [Click to Join Nageen CBSE Class 11 \(Science\) Channel](#)
- [Click to Join Nageen CBSE Class 11 \(Humanities\) Channel](#)
- [Click to Join Nageen CBSE Class 11 \(Commerce\) Channel](#)
- [Click to Join Nageen CBSE Class 12 \(Science\) Channel](#)
- [Click to Join Nageen CBSE Class 12 \(Commerce\) Channel](#)
- [Click to Join Nageen CBSE Class 12 \(Humanities\) Channel](#)

- [Click to Join JEE/NEET Channel](#)
- [Click to Join CUET Channel](#)
- [Click to Join NDA, OLYMPIAD, NTSE Channel](#)

Nageen ICSE Channels

- [Click to Join Nageen ICSE Kindergarten Channel](#)
- [Click to Join Nageen ICSE Class 1 Channel](#)
- [Click to Join Nageen ICSE Class 2 Channel](#)
- [Click to Join Nageen ICSE Class 3 Channel](#)
- [Click to Join Nageen ICSE Class 4 Channel](#)
- [Click to Join Nageen ICSE Class 5 Channel](#)
- [Click to Join Nageen ICSE Class 6 Channel](#)
- [Click to Join Nageen ICSE Class 7 Channel](#)
- [Click to Join Nageen ICSE Class 8 Channel](#)
- [Click to Join Nageen ICSE Class 9 Channel](#)
- [Click to Join Nageen ICSE Class 10 Channel](#)
- [Click to Join Nageen ICSE Class 11 \(Science\) Channel](#)
- [Click to Join Nageen ICSE Class 11 \(Commerce\) Channel](#)
- [Click to Join Nageen ICSE Class 11 \(Humanities\) Channel](#)
- [Click to Join Nageen ICSE Class 12 \(Science\) Channel](#)
- [Click to Join Nageen ICSE Class 12 \(Commerce\) Channel](#)
- [Click to Join Nageen ICSE Class 12 \(Humanities\) Channel](#)
- [Click to Join JEE/NEET Channel](#)
- [Click to Join CUET Channel](#)
- [Click to Join NDA, OLYMPIAD, NTSE Channel](#)