



**SNS College of Technology,  
Coimbatore- 35(Autonomous)**  
**B.E/B.Tech– Internal Assessment Examination I**  
**Department of Civil Engineering**



**Academic Year 2023-2024 (Even)**  
**VI Semester**  
**19CET304 – DESIGN OF STEEL STRUCTURES**  
**Unit I**

**1. What are the advantages of bolt connections over riveted connections?**

- There is a silence in preparing bolted connection. In riveting, hammering is done. The hammering causes noise in the riveting.
- There is no risk of fire in bolted connections. The rivets are made red hot in riveting and there is risk of fire.
- The bolted connections may be done quickly in comparison to the riveting.
- Noiseless
- Easy to dismantle and reuse the materials.

**2. Mention the types of failures in a riveted joint?**

- Shear failure of rivets
- Shear failure of plates
- Tearing failure of rivets
- Bearing failure of plates
- Splitting failure of plates at the edges
- Bearing failure of rivets

**3. What are the various failure modes of bolted connections?**

- Shear failure of bolt
- Shear failure of plates
- Tension failure of plate or tension failure of bolt
- Bearing failure of plate or bearing failure of bolt

**4. What is HSFG Bolt?**

HSFG (High Strength Friction Grip) bolts are made from high strength steel rods. Surface of the shank is kept unfinished in case of black bolts. These bolts are tightened to a proof load using calibrated wrenches. Hence they grip the members tightly.

**5. List out the different types of bolts.**

- Unfinished bolts
- Turned bolts
- Black bolts

- High strength bolt

**6. Name any two important advantages of structural steel.**

- They can erect at a faster rate.
- Steel is the ultimate recycling material.
- Properly maintained steel structures have a long life.
- Additions and alteration can be made easily to steel structures.
- These properties of steel mostly don't change with time.
- This makes steel most suitable material for its structure

**7. Define the limit states.**

The acceptable limit for the safety and serviceability requirements before failure occurs is called as limit state

**8. State the different limit states.**

- Limit state of strength.
- Limit state of serviceability.

**9. What are the advantages of bolted connections?**

- There is silence in preparing bolted connection. In riveting, hammering is done. The hammering causes noise in the riveting.
- There is no risk of fire in bolted connection. The rivets are made red hot in riveting and there is risk of fire.
- The bolted connections may be done quickly in comparison to the riveting.
- Though the cost of bolts is more than the cost of rivets, the bolted connections are economical to use because less persons are required for installation, and the work proceeds quickly.
- Noiseless
- Easy to dismantle and reuse the materials.

**10. Define: efficiency of a joint**

$$\text{Efficiency of a joint, } \eta = \frac{\text{strength of bolted joint} / \text{pitch length}}{\text{strength of solid plate} / \text{pitch length}} \times 100$$

**11. What are the disadvantages of bolted connections?**

- Tensile strength is reduced considerably due to stress concentrations and reductions of area at the threads.
- Rigidity of joints is reduced due to loose fit, resulting into excessive deflections.
- Due to vibrations nuts are likely to loosen, endangering the safety of the structures.

**12. What are the properties of structural steel?**

- Density. Density of a material is defined as mass per unit volume.
- Elastic Modulus.
- Poisson's Ratio.
- Tensile Strength.
- Yield Strength.
- Melting Point.
- Specific Heat.

- Hardness.

**13. How the rolled steel beams are classified?**

- Indian Standard junior beams (ISLB)
- Indian Standard light beams (ISLB)
- Indian Standard medium weight beams (ISMB)
- Indian Standard wide flange beams (ISWB)

**14.. What are the load combinations for the design purposes?**

- Dead load + Imposed Load (Live load)
- Dead Load + Imposed Load + Wind Load or earthquake load
- Dead Load + Wind Load or Earthquake load

**15. Mention the advantages and disadvantages of steel**

**structures? Advantages:**

- Ability to resist high loads
- Due to its high density, steel is completely non-porous
- Durability
- Easy to disassembling or replacing some steel members of a structure

**Disadvantages:**

- Corrosion
- At high temperature steel loses most of its strength, leading to deformation or failure

**16. How the loads are classified?**

- Dead load
- Live load
- Earthquake load
- Wind load
- Dynamic loads.

**17. What is a partial safety factor?**

The safety of the structure depends on each of the two principal design factors namely, load and material strength, which are not the functions of each other. Each of the two factors contributes partially to safety and they are termed as partial safety factors

**18. What are the various types of connections used for connecting the structural members?**

- Riveted connections
- Bolted connections
- Pin connections
- Welded connections

**19. Define Pitch & Gauge Distance**

- Pitch: It is the distance between the centres of two consecutive bolts measured along a row of bolts (Gauge Line). It is denoted by p.
- Gauge Distance: It is the distance between the two consecutive bolts of adjacent rows and is measured at right angles to the direction of load. It is denoted by g.

## 20. Define edge Distance

Edge distance (e) : It is the distance of center of bolt hole from the adjacent edge of plate.

## 21. What are the various types of bolts used for structural purposes?

- Unfinished bolts
- Turned bolts
- Black bolts
- High strength bolts

## 22. What are the advantages of HSFG bolts?

- Do not allow slip between the connected members.
- Loads are transferred by friction only.
- Due to high strength less number of bolts are required.
- No noise pollution
- Deformation is minimized.

## 23. Define nominal diameter and gross diameter of bolt.

### Nominal diameter of bolt:

The nominal diameter of a bolt is the diameter of unthreaded shank of bolt.

### Gross diameter of bolt:

The gross diameter of a bolt is the nominal diameter of the bolt.

## 24. Define weld.

The welding is one of the methods of connecting the structural members. In the welding, a metallic link is made between the structural members. The weld is defined as a union between two pieces of metal at faces rendered plastic or liquid by heat or by pressure or both

## 25. Write about the advantages of welding.

- There is silence in the process of welding.
- There is safety of welding operator in the welding
- The welding may be done quickly in comparison to the riveting.
- The welded joints have better appearance than riveted joints.
- The welded joints are more rigid than the riveted joints

## 26. Write about the disadvantages of welding.

- The members are likely to distort in the process of welding.
- A welded joint fails earlier than riveted joint, if the structure is under fatigue stresses.
- There is a greater possibility of brittle fracture in welding than the rivet.
- The inspection of welded joint is more difficult and more expensive than the riveted joint.

- More skilled person is required in the welding than in the riveting

**27. List the various types of welded joints.**

- Butt weld
- Fillet weld
- Slot weld and plug weld
- Spot weld

**28. What are properties of structural steel**

**2.2.4 Properties**

The properties of structural steel for use in design, may be taken as given in 2.2.4.1 and 2.2.4.2.

**2.2.4.1 Physical properties of structural steel irrespective of its grade may be taken as:**

- Unit mass of steel,  $\rho = 7850 \text{ kg/m}^3$
- Modulus of elasticity,  $E = 2.0 \times 10^5 \text{ N/mm}^2$  (MPa)
- Poisson ratio,  $\mu = 0.3$
- Modulus of rigidity,  $G = 0.769 \times 10^5 \text{ N/mm}^2$  (MPa)
- Co-efficient of thermal expansion  $\alpha_t = 12 \times 10^{-6} / ^\circ\text{C}$

**2.2.4.2 Mechanical properties of structural steel**

The principal mechanical properties of the structural steel important in design are the yield stress,  $f_y$ ; the tensile or ultimate stress,  $f_u$ ; the maximum percent elongation on a standard gauge length and notch toughness. Except for notch toughness, the other properties are determined by conducting tensile tests on samples cut from the plates, sections, etc, in accordance with IS 1608. Commonly used properties for the common steel products of different specifications are summarized in Table 1.

**29. What are the types of Joints in Bolted Connections?**

**1. Lap Joint**

In a lap joint, the main members to be connected are placed over one another to form an overlap between the members, and then the bolting is done on the overlapped portion. Because of the very nature of the connection, an eccentricity is produced.

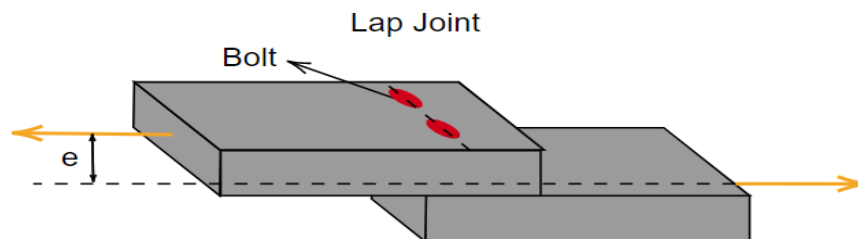

**2. Butt Joint**

In this type of joint, a cover plate is used to join two members. Based on the number of cover plates there are two types of butt joint namely, single cover butt joint and double cover butt joint.

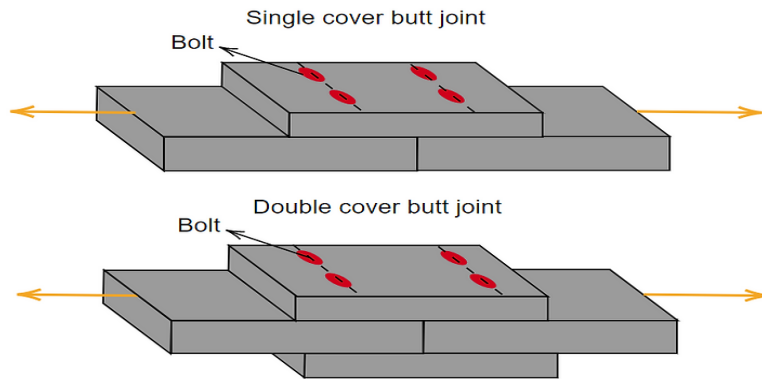

30. Write difference between fillet and butt weld

## Difference Between Fillet Weld And Butt Weld

| Fillet Weld   | Butt Weld   |
|---|---|
| simple, fast and economical to make                   | more expensive than fillet welds because of the edge preparation required |
| no prior edge preparation is necessary,               | easily designed and fabricated to be as strong as the member              |
| does not require very skilled labour.                 | require more skilled manpower, than that required for filled welds.       |
| less attractive in appearance.                        | better appearance, compared to fillet welds, and                          |
| poorer performance under fatigue loading, and         | better fatigue characteristics, compared to fillet welds,                 |
| Throat thickness= $0.707 \times$ weld size            | Thickness= $(5/8) \times$ thickness of thinner plate                      |
| not appropriate to transfer forces large in magnitude | easy to detail and the length of the connection is considerably reduced.  |

31. Give the sketches of steel sections?

### Channel, Angle, T and Solid Sections

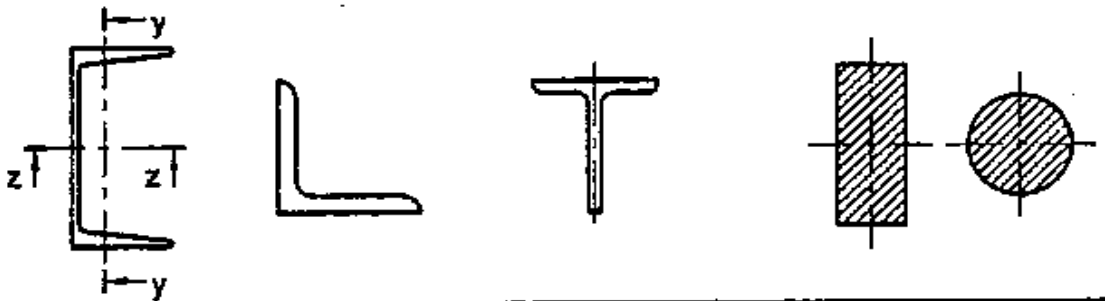

## PART B

1. A single-bolted double-cover butt joint is used to connect two plates which are 8 mm thick. Assuming 16 mm diameter bolts of grade 4.6 and cover plates to be 6 mm thick, calculate the strength and efficiency of the joint, if 4 bolts are provided in the bolt line at a pitch of 45 mm as shown in Fig. 1. Also, determine the efficiency of the joint if two lines of bolts with two bolts in each line have been arranged to result in a double-bolted double-cover butt joint.

Also determine the efficiency of the joint if two lines of bolts with bolts in each line have been arranged to result in a double-bolted cover butt joint. Fig.2

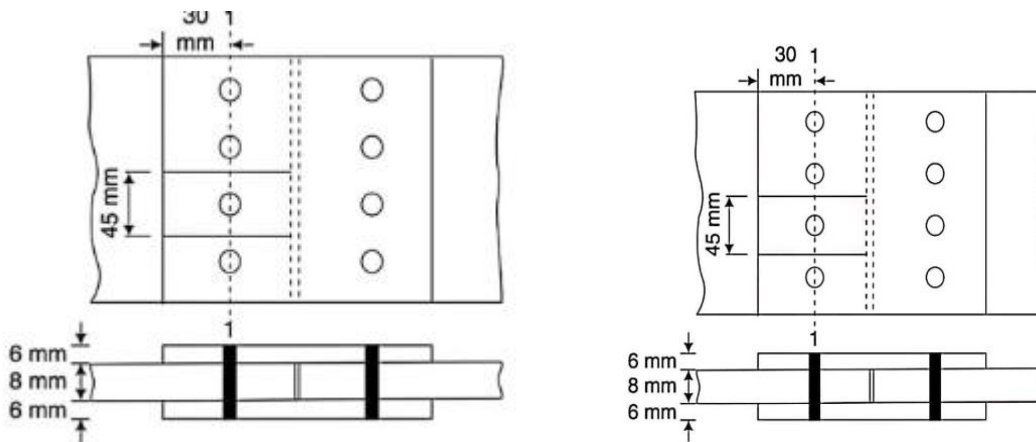

*Figure 1*

*Figure 2*

2. Determine strength and efficiency of the lap joint as shown in fig. The bolts are 20mm diameter and 4.6 grade. The two plates to be joined are 10mm and 12mm. Steel grade is Fe410.

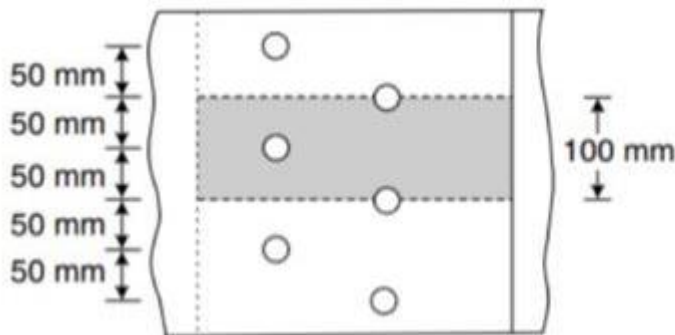

3. Two flats Fe 410 grade steel each 210mmx 8mm are to be joined using 16mm diameter 4.6 grade bolt to form a lap joint. The joint is supposed to transfer a factored load 240kN. Design the joint and determined suitable pitch for the bolts

4. Two flats Fe 410 grade steel each 210mmx 8mm are to be joined using 18mm diameter 4.6 grade bolt to form a lap joint. The joint is supposed to transfer a factored load 250kN. Design the joint and determined suitable pitch for the bolts.

5. Two ISF section 200mm X 10mm each and 1.5m long are to be joined to make a member length of 3.0m. Design a butt joint with the bolts arranged in the diamond pattern. The flat are supposed to carry a service load 300KN. 20mm diameter bolts of grade 4.6 are used to make the connections. Also, determine the net tensile strength of the main plate and cover plate. Steel is of grade Fe410.

6. Two ISF section 200mm X 10mm each and 1.5m long are to be joined to make a member length of 3.0m. Design a butt joint with the bolts arranged in the diamond pattern. The flat are supposed to carry a service load 450KN. 20mm diameter bolts of grade 4.6 are used to make the connections. Also, determine the net tensile strength of the main plate and cover plate. Steel is of grade Fe410.

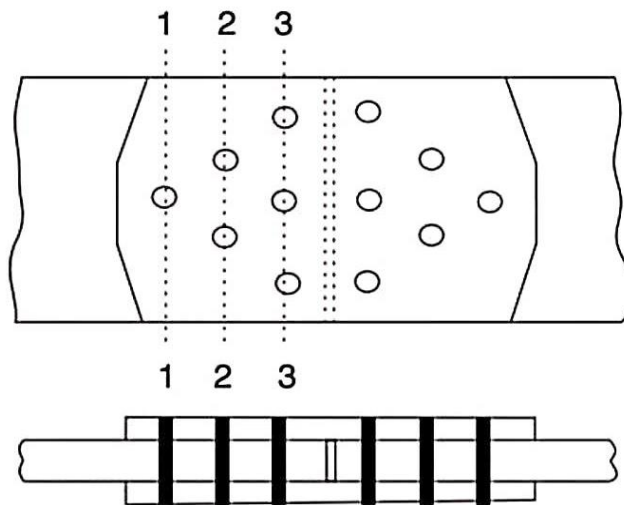

7. Two ISF section 200mm X 10mm each and 1.5m long are to be joined to make a member length of 3.0m. Design a butt joint with the bolts arranged in the diamond pattern. The flat are supposed to carry a service load 300KN. 20mm diameter bolts of grade 4.6 are used to make the connections. Also, determine the net tensile strength of the main plate and cover plate. Steel is of grade Fe410.



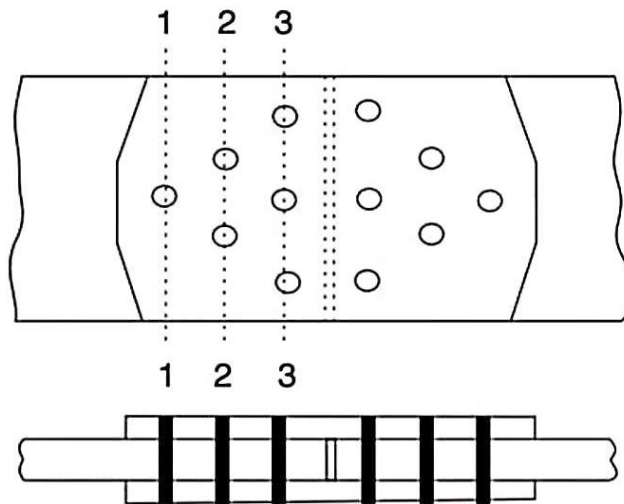

8. Two plates of 16mm and 14mm thick are to be joined by groove weld . The joint is subjected to a factored tensile force of 430kN. Effective length of weld is 175mm.

Check the safety of the joint if

- (a) Single –V groove weld is provide
- (b) Double –V groove weld is provided

Assume the plates to be shop welded

9. A tie member 75mm x 8mm is to be transmit a factored load of 145kN. Design the fillet welds and necessary overlaps for cases as shown if figures. The steel grade is Fe410. Assume gusset plate to be 12mm thick

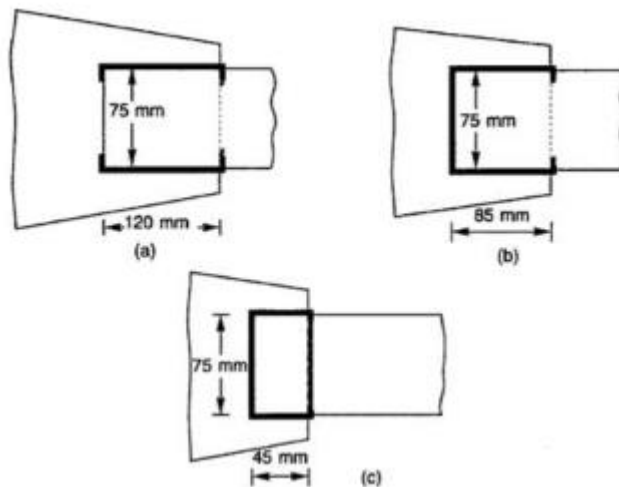

10. An ISLC 300 @ 324.7 N/m (Fe 410 grade of steel) is to carry a factored tensile force of 900 kN. The channel section is to be welded at the site to a gusset plate 12 mm thick. Design a fillet weld, if the overlap is limited to 350 mm.

## Unit II – Design of Tension members

### 1. Define tension member.

A tension member is defined as a structural member subjected to tensile force in the direction parallel to its longitudinal axis. A tension member is also called as a tie member or simply a tie

### 2. What are the various types of tension members?

- Wires and cables
- Rods and bars
- Single structural shapes and plates
- Built-up members

### 3. What is meant by built-up members? (IS800:2007-Pg: 1)

Two or more than two members are used to form built-up members. The built-up sections may be made more rigid and stiffer than the single structural shapes. A built-up section may be made of two channels placed back to back. Define slenderness ratio. (IS800:2007-Pg: 4)

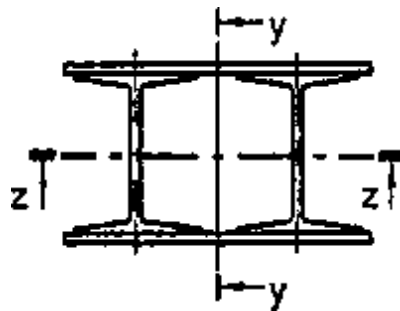

### 4. Define slenderness ratio. (IS800:2007-Pg: 4)

The slenderness ratio of a tension member is the ratio of its unsupported length ( $l$ ) to its least radius of gyration ( $r$ ).

$$\text{Slenderness ratio, } \lambda = l/r.$$

### 5. What is net sectional area?

The net sectional area of a tension member is the gross-sectional area of the member less the maximum deduction for holes.

$A_{net} = A_{gross} -$  sectional areas of holes back with a gusset plate in between them.

### 6. How to calculate net area in (a) chain bolting (b) zigzag bolting. (IS800:2007-Pg: 33)

#### a) Chain bolting

Net area,  $A_n = (b - n d_h) t$

b) **Zigzag bolting**

$$A_n = \left[ b - n d_h + \sum_i \frac{p_{si}^2}{4g_i} \right] t$$

### 7. What is block shear?

For some connections configurations, the tension member can fail due to 'tear-out' of material at the connected end. This is called block shear

### 8. What is shear lag effect?

The tensile force is transferred from gusset to the tension member (such as angle, channels or T-sections) through one leg by bolts or welds. In this process initially the connected leg may be subjected to more stress than the outstanding leg and finally the connection. Thus one part lags behind the other, this is referred to as shear.

### 9. Differentiate gross and net area

Gross area:

Total area of the cross section which can be taken as equal weight of the member per unit length divided by density of the material is called the gross area. The sectional area given by manufacture is taken as the gross area.

Net area:

The net sectional area of a tension member is the gross sectional area of the member less than maximum deduction for holes.

### 10. What is the difference between the pitch and staggered pitch?

**Pitch(S):**

It is the distance between centers of two adjacent rows of bolt/rivets in a row. It is measured parallel to the direction of the force.

**Staggered pitch:**

It occurs in the case of zigzag riveting/bolt between the double bolt/rivet lines. This is the c/c distance between any two consecutive bolts /rivets. It is measured parallel to the direction of the **force acting on the member**.

### 15. What are the failures in tension members?

1. Gross section yielding
2. Net section rupture

### 3.. Block shear failure

#### 16. What do you understand by block shear failure?

Block shear failure is characterized by tearing out of a segment or block of material at the end of the member for a certain connection configurations and in coped beams. The block shear failure occurs along a path involving tension on one plane and shear on a perpendicular plane.

#### 17. Give the properties of ISMC 300.

Refer steel table

#### 18. What do you understand by Gross area?

Total area of cross section which can be taken as equal weight of the member per unit length divided by density of the material is called Gross area. The sectional area given by the manufacturer is taken as the gross area.

#### 19. Explain shear lag effect. (IS800:2007-Pg: 4)

The tensile force is transferred from gusset to the tension member (such as angles, channels or T- sections) through one leg by bolts or welds. In this process initially the connected leg may be subjected to more stress than the outstanding leg and finally the stress distribution becomes uniform over the section away from the connection. Thus one part lags behind the other; this is referred to as shear lag.

**1.3.88 Shear Lag — The in plane shear deformation effect by which concentrated forces tangential to the surface of a plate gets distributed over the entire section perpendicular to the load over a finite length of the plate along the direction of the load.**

#### 20 What is a Lug angle?

In order to increase the efficiency of the outstanding leg in single angles and to decrease the length of the end connections, sometimes a short length angle at the ends are connected to the gusset and the outstanding leg of the main angle directly, as shown in Fig.. Such angles are referred to as lug angles. It also reduces shear lag.

#### 21. Where do you use lug angles?

- the connection are small
- The size of gusset plate is economical
- To reduce the length of the joint

#### 22. Write the purpose of using lug angles.

1. To reduce the length of connection to the gusset plate
2. To reduce shear lag effect.

#### 23. What is tension splice?

When a butt joint is covered by plates on both sides, then it is called splicing. The cover plates used to joint tension members are known as tension splice. Tension splicing is done in the following two cases:

- When the size of tension member changes at different length.
- When the length of the section available is less than the required.

#### **4. Write note on tension member splice.**

A tension member is spliced when the available length is less than the required length of the tension member. A tension member is also spliced when the members of different thickness are required to be connected. In such a case packing is required to fill up the gap.

#### **5. Why is tension splice needed?**

**Splices : Splices in tension member are used to join two sections when a joint is to be provided i.e. these replace the members at the joint where it is cut. The splice section as well as the connection are designed for the tensile load to be transmitted by the main tension member i.e. for the strength of main member.**

## PART B

1. Determine the net effective area of angle section as shown in fig. The angles are connected with 18mm diameter bolts of grade 4.6, Grade of steel is Fe410

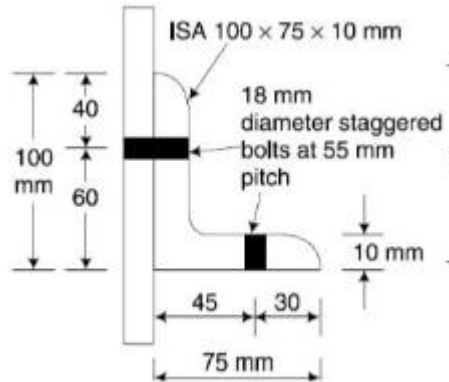

2. Determine the net effective area of angle section as shown in fig. The angles are connected with 18mm diameter bolts of grade 4.6, Grade of steel is Fe410

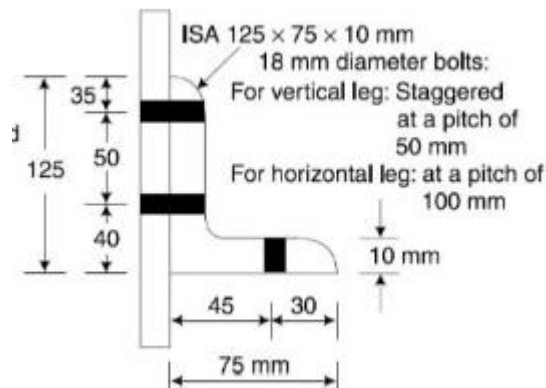

3. A single unequal ISA 90 x60 X 6mm is connected to 10mm gusset plate at the end with 5 numbers of 16mm diameter bolts to transfer tension. Determine the tensile strength of the angle if the gusset plate is connected to 60mm leg. Take pitch as 40mm and edges distance as 30mm. Also check for reversal stress or slenderness ratio.. Taking length = 2.5m

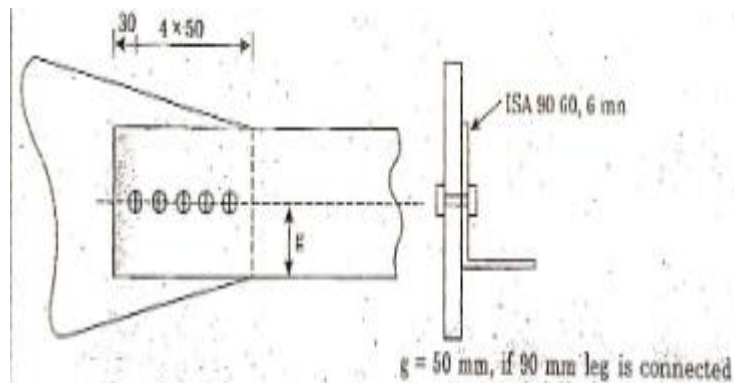

4.

**Example 7.4** Determine the effective net area of double angle section connected to a gusset plate, 12 mm in thickness, as shown in Fig. , for the following data.

Diameter of bolts = 16 mm

Number of bolts = 6

Pitch of bolts = 40 mm

Edge distance of bolts = 30 mm

Grade of bolts: 4.6

Grade of steel: Fe 410

Angles: tack bolted

( $f_y = 250$  MPa)

What will be the effective net area if the angles are not tack bolted?

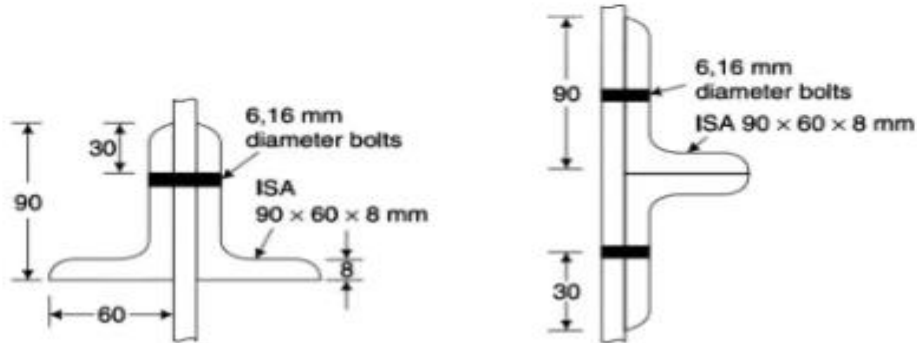

5.

Determine the design tensile strength of the plate 120 mm x 8 mm connected to a 12 mm thick gusset plate with bolt holes as shown in Fig. 11. The yield strength and ultimate strength of the steel used are 250 MPa and 400 MPa. The diameter of the bolts used is 16 mm.

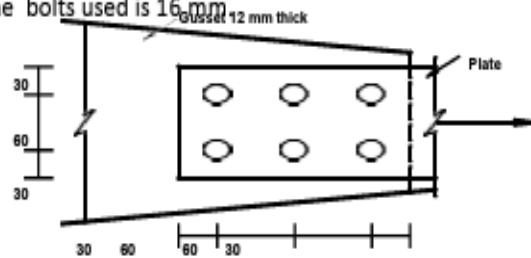

Fig. 11 Details of end connection

6.

A single unequal angle 100 x 75 x 8 mm is connected to a 12 mm thick gusset plate at the ends with 6 numbers of 20 mm diameter bolts to transfer tension as shown in Fig. 13. Determine the design tensile strength of the angle if the gusset is connected to the 100 mm leg. The yield strength and ultimate strength of the steel used are 250 MPa and 400 MPa. The diameter of the bolts used is 20 mm.

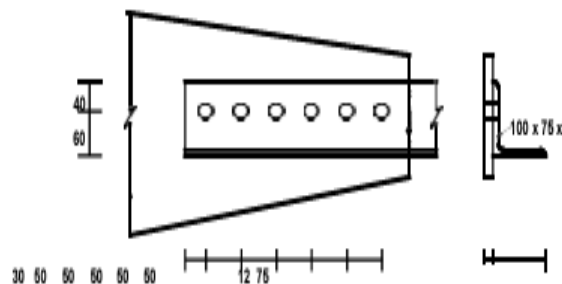

Fig. 13 Details of end connection

7. Design a tie member consisting of single angle section to carry a working load of 150kN. Use bolted connection with M18 of 4.6 grade bolt. If the length of the member is 2m, check the slenderness ratio.

8. Design a splice for joining tension member sections 160 x 10mm and 250x14mm. The member is subjected to factored tensile load of 300kN. Assume Fe410 grade steel. Provide 20mm diameter bolts of grade 4.6, for making connections.

9. Design a splice to connect a 300mm x 20mm with a 300mm x 10mm plate. The factored design load is 500kN. Use 20mm diameter black bolt.



## Unit III

### DESIGN OF COMPRESSION MEMBERS

#### 1. What is meant by strut? (IS800:2007-Pg: 5)

A strut is defined as a structural member subjected to compression in a direction parallel to its longitudinal axis. The term strut is commonly used for compression members in roof trusses.

#### 2. What is meant by effective sectional area?

The effective sectional area of a compression member is the gross cross sectional area of the member. The deduction is not made for members connected by rivets, bolts and pins.

#### 3. Define slenderness ratio of compression member.

The slenderness ratio of a compression member is the ratio of effective length of

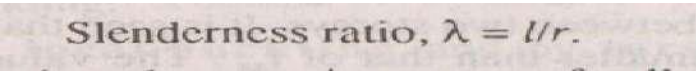
$$\text{Slenderness ratio, } \lambda = l/r.$$

#### 4. Draw the diagram of buckling of column.

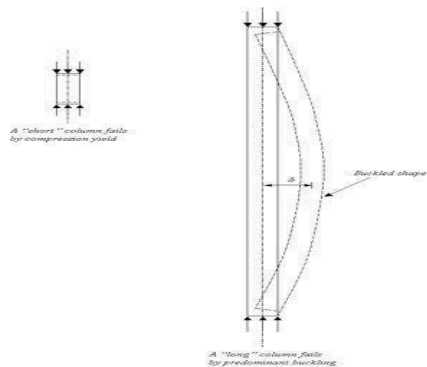

#### 5. Define compression member

A **compression Member** is a structural member which is subjected to two equal opposite compressive forces applied at its end. Structural elements that are subjected to axial compressive forces are only called columns. A compression member may be a short column or long column based on the slenderness ratio criteria.

#### 6. Classify the modes of failures in compression member.

##### Modes of Failure in Compression Member

In a compression member, there are several factors due to which compression members fail. The failure depends on the column type (depending upon slenderness ratio).

- The compression member fails due to buckling and crushing in the case of the column.
- Crushing or Yielding failure is shown in a short column.
- Buckling failure is further classified into elastic buckling and inelastic buckling. When the compression member translates perpendicular to the applied load, it shows in the long column.
- The intermediate column fails due to inelastic failure. This failure is the combination of yielding and lateral buckling in a column.

#### 7. Name the Types of Sections for Compression Members

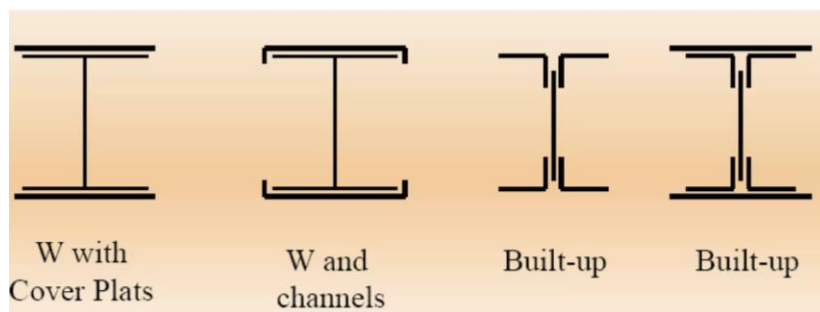
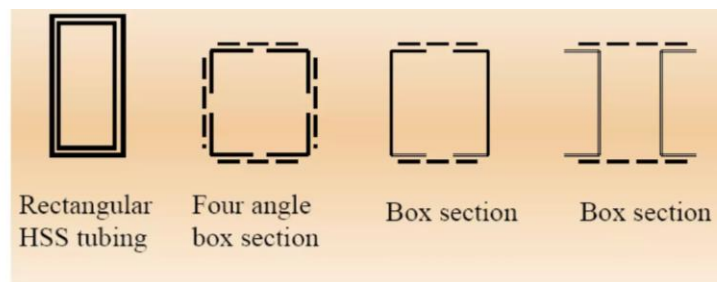
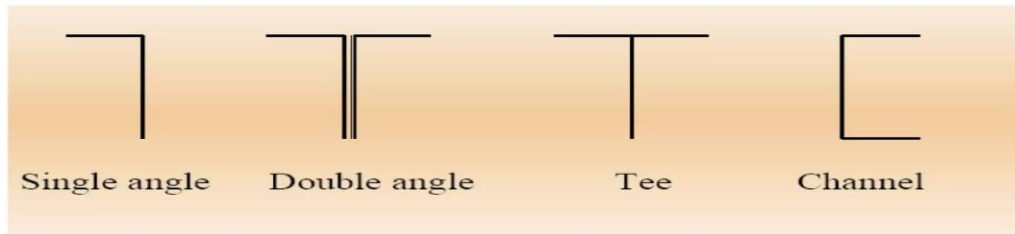

**8. What is meant by built-up compression members?**

The built-up compression members are needed when the single rolled steel sections are not sufficient to furnish the required cross-sectional area. A built-up compression member may consist of two or more rolled structural steel sections connected together effectively and acts as one compression member.

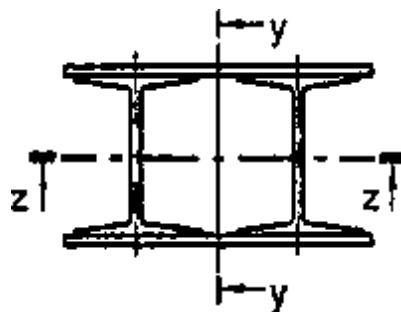

9. Define effective length.

The effective length of a compression member is the distance between the points of contra flexures of a buckled column. It depends on the actual length and the end conditions in regards to restraint against rotation and transverse displacement.

10. What is meant by actual length?

The actual length is taken as the length from centre-to-centre of intersections with the supporting members.

12. How the effective length of column is determined?

The effective length of columns in framed structures may be obtained by multiplying the actual length of the column between the centers of laterally supporting members (beams) given with the effective length factor K.

$$\text{Effective length} = KL$$

13. What are the different effective lengths for different boundary condition?

**Table 11 Effective Length of Prismatic Compression Members**  
(Clause 7.2.2)

| Boundary Conditions |                 |                    |                 | Schematic Representation | Effective Length |
|---------------------|-----------------|--------------------|-----------------|--------------------------|------------------|
| At One End          |                 | At the Other End   |                 |                          |                  |
| Translation<br>(1)  | Rotation<br>(2) | Translation<br>(3) | Rotation<br>(4) |                          |                  |
| Restrained          | Restrained      | Free               | Free            |                          | 2.0L             |
| Free                | Restrained      | Free               | Restrained      |                          | 1.0L             |
| Restrained          | Free            | Restrained         | Free            |                          | 1.2L             |
| Restrained          | Restrained      | Free               | Restrained      |                          | 0.8L             |
| Restrained          | Restrained      | Restrained         | Free            |                          | 0.65L            |

14. Define single lacing & double lacing. (IS800:2007-Pg: 48 & 49)

**7.6.1.4** Single laced systems, on opposite faces of the components being laced together shall preferably be in the same direction so that one is the shadow of the other, instead of being mutually opposed in direction.

Double laced system, on opposite faces of the components being laced together shall preferably be in mutual opposed in direction.

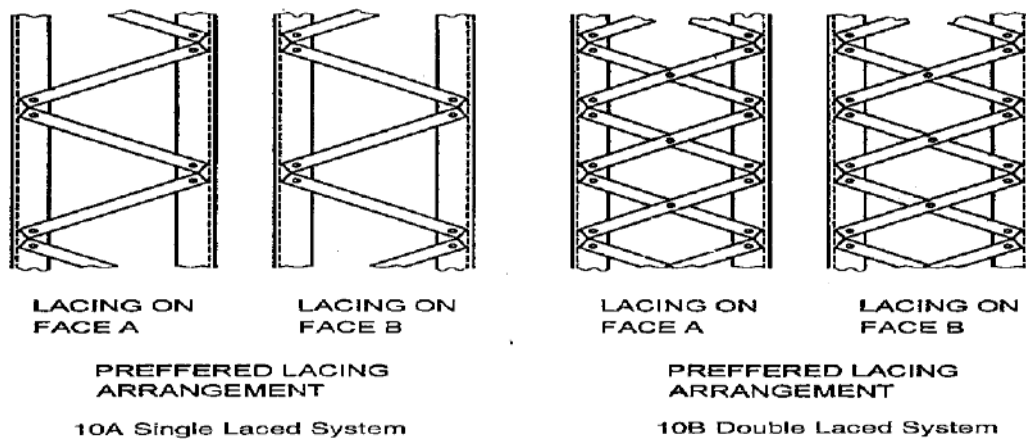

16. What are the forces acting on lacing system?

The forces acting on lacing system are transverse shear force and axial force.

17. Draw the column base plate diagram. (Nov / Dec 2005)

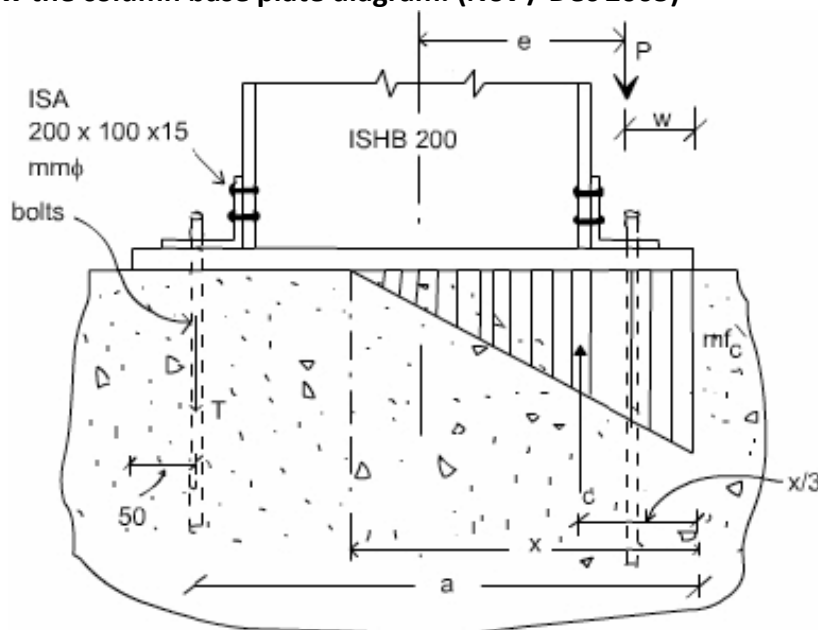

18. *Where should the splice plate be located in a column?(IS800:2007-Pg:46)*

**7.3.4.1** Where the ends of compression members are prepared for bearing over the whole area, they shall be spliced to hold the connected members accurately in position, and to resist bending or tension, if present. Such splices should maintain the intended member stiffness about each axis. Splices should be located as close to the point of inflection as possible. Otherwise their capacity should be adequate to carry magnified moment

19. **Define Column Base**

The column base is the interface between the columns and their foundation. Column base reduces the intensity of loading and distributing it over the foundation. The area of the column base or base plate is chosen so that the intensity of load distributed is less than the bearing capacity of concrete on which the plate resists. It also maintains the proper alignment of columns in a plan.

20. **Which type of column is used for heavy loading?**

Gusseted base plates are used for columns carrying heavy loads and loads accompanied by moments. In this case, fastenings are used to connect the base plate and the column in the form of vertical gusset plates and gusset angles.

21. **What are the types of bases provided for connecting the column to the base?**

- Slab base
- Gusseted base
- Moment resisting base

22. *Under what circumstances gusset base is used?*

When the load on the column is large or when the column is subjected to moment along with axial load, gusseted base is provided. It consists of a base plate, gusset plate, connecting angles provided on either side of the column and web cleat angle.

23. *Write about batten plates in compression member.*

When compression members are required for large structures like bridges, it will be necessary to use built-up sections. They are particularly useful when loads are heavy and members are long (e.g. top chords of Bridge Trusses). The cross section consists of two channel sections connected on their open sides with some type of lacing or latticing (dotted lines) to hold the parts together and ensure that they act together as one unit. The ends of these members are connected with "batten plates" which tie the ends together.

24. Which column formula is recommended in IS 800:2007? (Pg: 34)

**7.1.2.1** The design compressive stress,  $f_{cd}$ , of axially loaded compression members shall be calculated using the following equation:

$$f_{cd} = \frac{f_y / \gamma_{m0}}{\phi + [\phi^2 - \lambda^2]^{0.5}} = \chi f_y / \gamma_{m0} \leq f_y / \gamma_{m0}$$

where

$$\phi = 0.5 [1 + \alpha (\lambda - 0.2) + \lambda^2]$$

$\lambda$  = non-dimensional effective slenderness ratio

$$= \sqrt{f_y / f_{cc}} = \sqrt{f_y (KL/r)^2 / \pi^2 E}$$

$$f_{cc} = \text{Euler buckling stress} = \frac{\pi^2 E}{(KL/r)^2}$$

where

$KL/r$  = effective slenderness ratio or ratio of effective length,  $KL$  to appropriate radius of gyration,  $r$ ;

$\alpha$  = imperfection factor given in Table 7;

$\chi$  = stress reduction factor (see Table 8) for different buckling class, slenderness ratio and yield stress

$$= \frac{1}{[\phi + (\phi^2 - \lambda^2)^{0.5}]}$$

$\lambda_{m0}$  = partial safety factor for material strength.

25. What are the functions of providing column bases?

The basic function of bases is to distribute the concentrated load from the column over a larger area. The column load is distributed over the base plate and then to supporting concrete and finally to the soil.

26. What is meant by column splice?

A joint in the length of a column provided, when necessary, is known as column splice. It is also described as column joint.

27. List the limiting slenderness ratio of compression member carrying dead load & live load. (April / May 2008)(IS800:2007-Pg: 20)

**Table 3 Maximum Values of Effective Slenderness Ratios**

| Sl No. | Member  | Maximum Effective Slenderness Ratio (KL/r) |
|--------|---|--|
| (1)    | (2)   | (3)  |
| i)     | A member carrying compressive loads resulting from dead loads and imposed loads | 180  |

27. What is meant by slab base?

The slab base as shown in Figure consists of cleat angles and base plate. The column end is faced for bearing over the whole area. The gussets (gusset plates and gusset angles) are not provided with the column with the slab bases. The sufficient fastenings are used to retain the parts securely in place and to resist all moments and forces, other than the direct compression. The forces and moments arising during transit, unloading and erection are also considered

28. Differentiate between slab base and gusseted base for the steel column

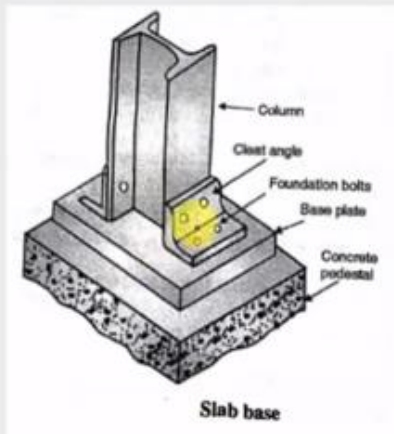

- Slab base are used in columns carrying **small loads**. In this type, the column is directly connected to the base plate through cleat angles
- The load is transferred to the base plate through bearing.

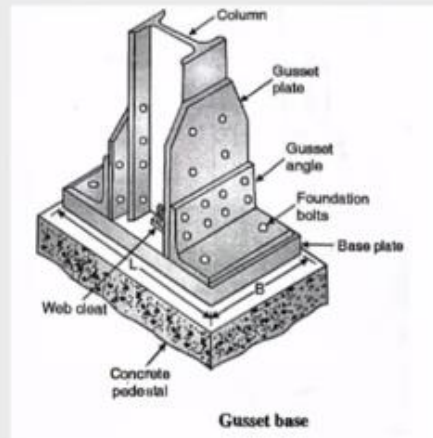

- For columns carrying **heavy loads** gusseted bases are used. In gusseted base, the column is connected to base plate through gusset.
- The load is transferred to the base Partly through bearing and partly through gusset.

## Part B

1. Determine the axial load capacity of the column section ISHB250@547N/m, if the length of the column is 3m and both ends of column are pinned.
2. Design the compressive strength of a bolted steel angle section 90 x 90 x12mm @158 N/m with length of the member is 2.8m.If both ends are hinged.
- 3 .Design a double angle discontinues strut to carry a factored load of 135kN. The centre to centre length of strut is 3. The angles are placed back to back on opposite side of Gusset plate.
4. Determine the load carrying capacity of a compound column consisting of ISMB400@61.6kg/m with one cover plate of 300 x200mm on each flange and having a length of 5m. One end of column is fixed and other end is pinned. Take  $f_y = 250\text{N/mm}^2$ .
5. Design a built-up column 10m long to carry factored axial load of 1080kN. The column is restrained in position but not in direction at the both ends. Design the column with two channels placed back to back. Provide single lacing system with bolted connections. Assume Fe410 grade steel and 4.6 grade bolt
- 6.. Design a slab base for a column ISHB350@67.4kg/m carrying factored load of 100kN. Also design the welded connection between slab base column. Use M20 grade concrete.
7. A column ISHB350@661.2N/m subjected to a compressive factored load of 1800kN. Design suitable bolted gusseted base. The base rests on M20 grade concrete pedestal. Use 24mm diameter bolt of grade 4.6 for making connection between gusset plate and column flange.
8. A column ISHB400@77.4kg/m with one 300mmx12mm flange plate each side. The column carries an axial load of 2600kN. Design suitable bolted gusseted base, if the column is supported on concrete pedetstal with a bearing pressure of 5N/mm<sup>2</sup>