



SNS COLLEGE OF TECHNOLOGY

(An Autonomous Institution)



COIMBATORE-35

**Accredited by NBA-AICTE and Accredited by NAAC – UGC with A++ Grade
Approved by AICTE, New Delhi & Affiliated to Anna University, Chennai**

**DEPARTMENT OF ELECTRICAL AND ELECTRONICS
ENGINEERING**

**COURSE NAME: 23EET101/BASIC ELECTRICAL AND
ELECTRONICS ENGINEERING**

I YEAR / I SEMESTER

Unit IV – ANALOG ELECTRONICS

Topic : Applications



BRIDGE RECTIFIER

- **Bridge rectifier** is a type of full-wave rectifier that uses four diodes arranged in a bridge configuration to convert AC to DC
- Four diodes D_1 , D_2 , D_3 , D_4 , and a load resistor R_L .
- The input signal is applied across terminals A and B, and the output DC signal is obtained across the load resistor R_L connected between terminals C and D.

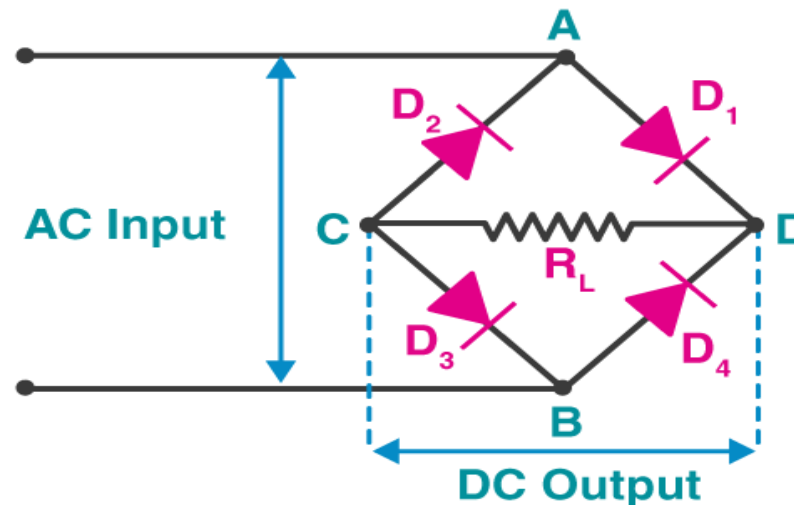



BRIDGE RECTIFIER - WORKING

During the **Positive half-cycle**, terminal A becomes positive while terminal B becomes negative. This causes diodes D_1 and D_3 to become forward biased and diode D_2 and D_4 to be reverse biased

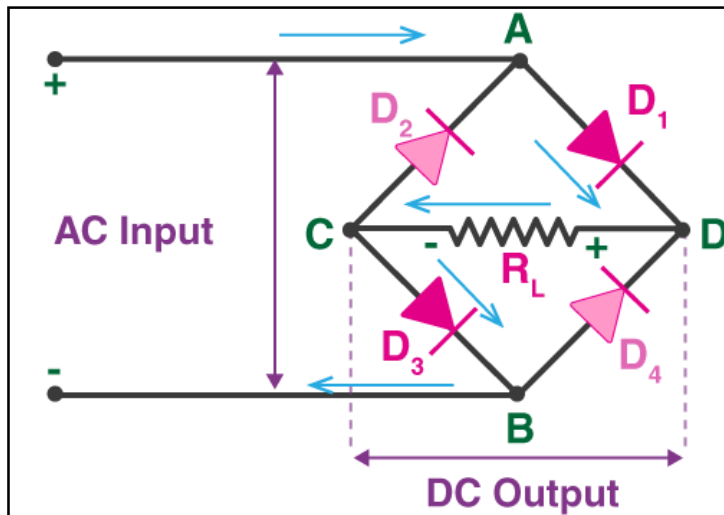

During the **Negative half-cycle**, terminal B becomes positive while terminal A becomes negative. This causes diodes D_2 and D_4 to become forward biased and diode D_1 and D_3 to be reverse biased

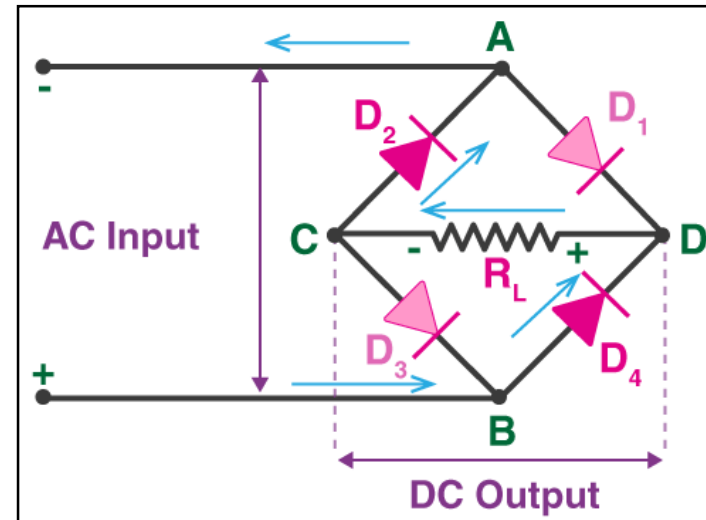



OUTPUT & APPLICATION

- The output DC signal polarity may be either completely positive or negative.

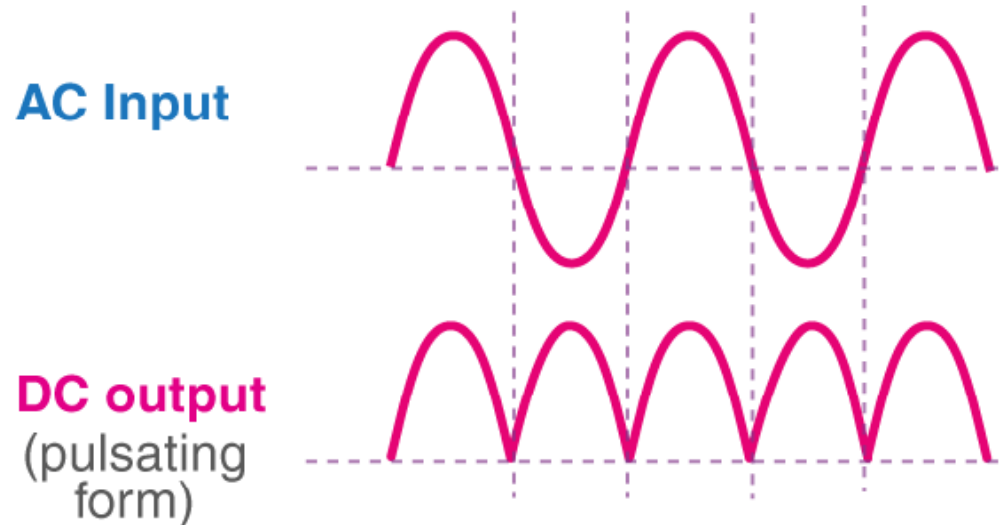

- Bridge rectifiers are used in the modulation of radio signals.
- They are used to convert AC voltage into low DC.
- They are also used in [electric welding](#).
- Bridge rectifiers mainly act as power supply units.



*Thank
you!*