



SNS COLLEGE OF TECHNOLOGY

An Autonomous Institution

Coimbatore-35



Accredited by NBA – AICTE and Accredited by NAAC – UGC with 'A+' Grade
Approved by AICTE, New Delhi & Affiliated to Anna University, Chennai

DEPARTMENT OF ELECTRONICS & COMMUNICATION ENGINEERING

19ECB301-ANALOG AND DIGITAL COMMUNICATION

III YEAR/ V SEMESTER

UNIT 4 – DIGITAL MODULATION TECHNIQUES

TOPIC – **BPSK**



PHASE SHIFT KEYING

In phase shift keying, the phase of the carrier is varied to represent two or more different signal elements (Both peak amplitude and frequency remain constant).

In binary PSK, we have only two signal elements: one with a phase of 0° , and the other with a phase of 180° .

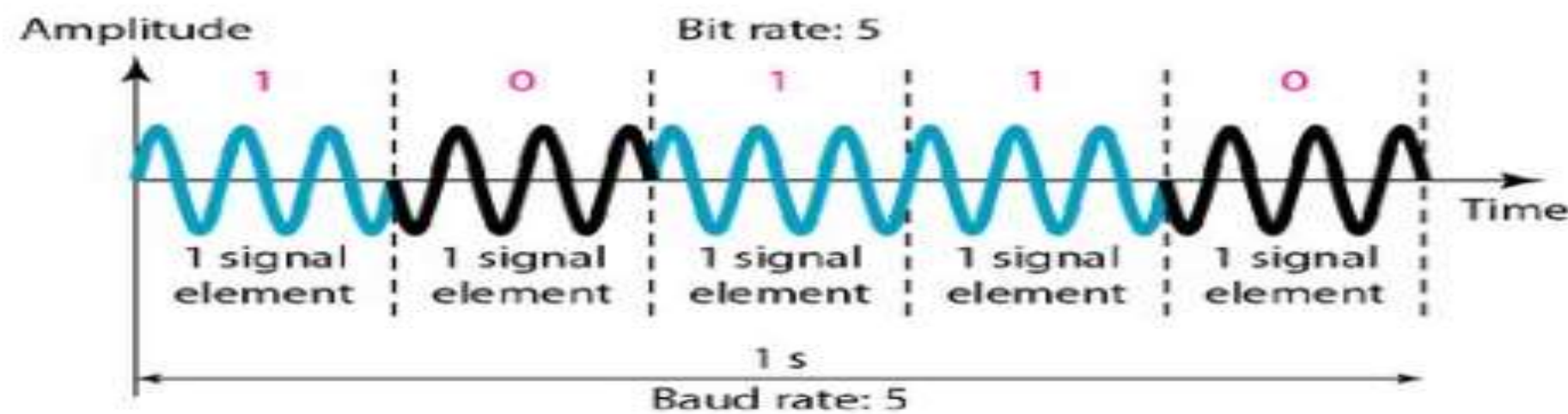

Bit	Phase
0	0
1	180

Bits

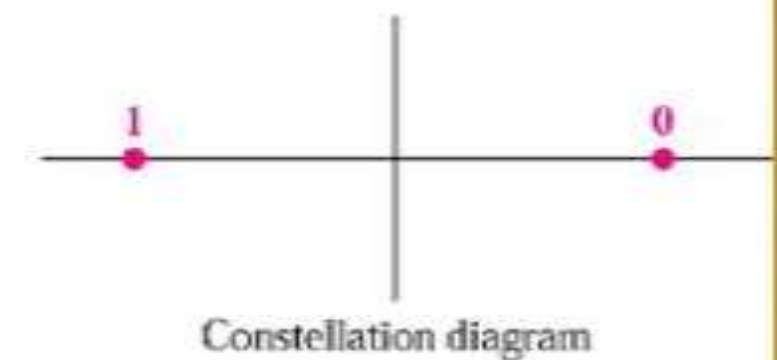



4.7.1 Principle of BPSK

In Binary Phase Shift Keying (BPSK), binary symbol '1' and '0' modulate the phase of the carrier. Let the carrier be,

$$s(t) = A \cos(2\pi f_0 t) \quad \dots (4.7.1)$$

'A' represents peak value of sinusoidal carrier. In the standard 1Ω load register, the power dissipated will be,

$$P = \frac{1}{2} A^2$$

$$\therefore A = \sqrt{2P} \quad \dots (4.7.2)$$



When the symbol is changed, then the phase of the carrier is changed by 180 degrees (π radians).

Consider for example,

$$\text{Symbol '1'} \Rightarrow s_1(t) = \sqrt{2P} \cos(2\pi f_0 t) \quad \dots (4.73)$$

If next symbol is '0' then,

$$\text{Symbol '0'} \Rightarrow s_2(t) = \sqrt{2P} \cos(2\pi f_0 t + \pi) \quad \dots (4.74)$$

Since $\cos(\theta + \pi) = -\cos \theta$, we can write above equation as,

$$s_2(t) = -\sqrt{2P} \cos(2\pi f_0 t) \quad \dots (4.75)$$

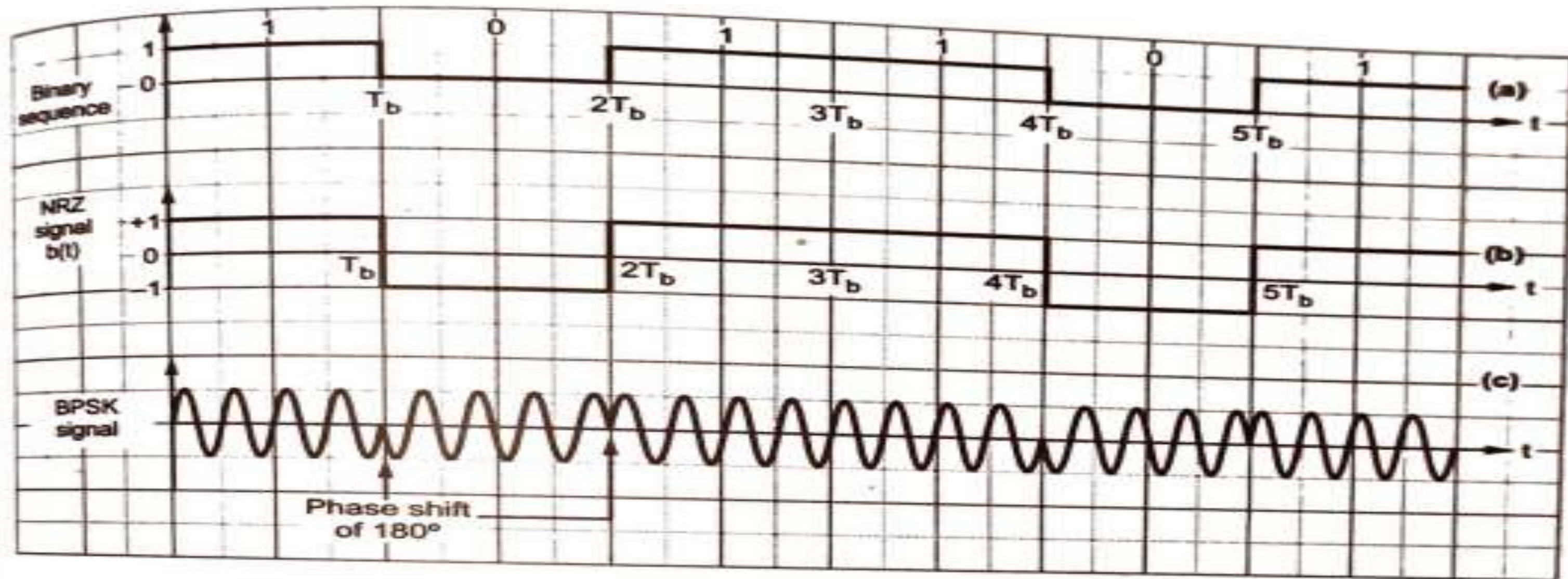

Fig. 4.7.1 (a) Binary sequence
(b) Its equivalent bipolar signal $b(t)$
(c) BPSK signal



BPSK - Generator

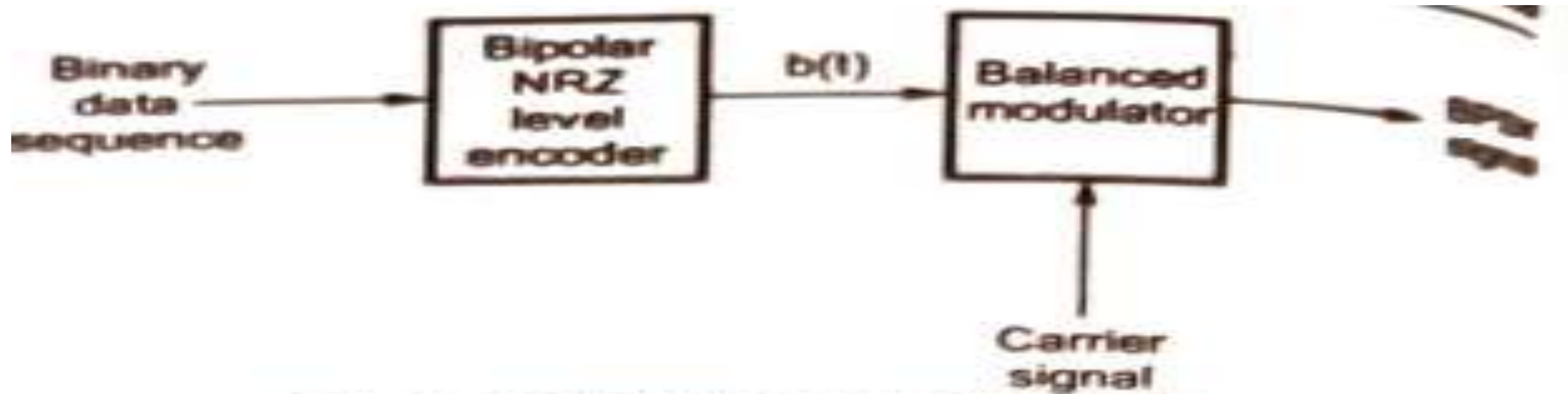

Fig. 4.7.2 BPSK generation scheme



BPSK - Receiver

Fig. 4.7.3 shows the block diagram of the scheme to recover baseband signal from BPSK signal. The transmitted BPSK signal is,

$$s(t) = b(t) \sqrt{2P} \cos(2\pi f_0 t)$$

$$s(t) = b(t) \sqrt{2P} \cos(2\pi f_0 t + \theta)$$

... (4.7.7)

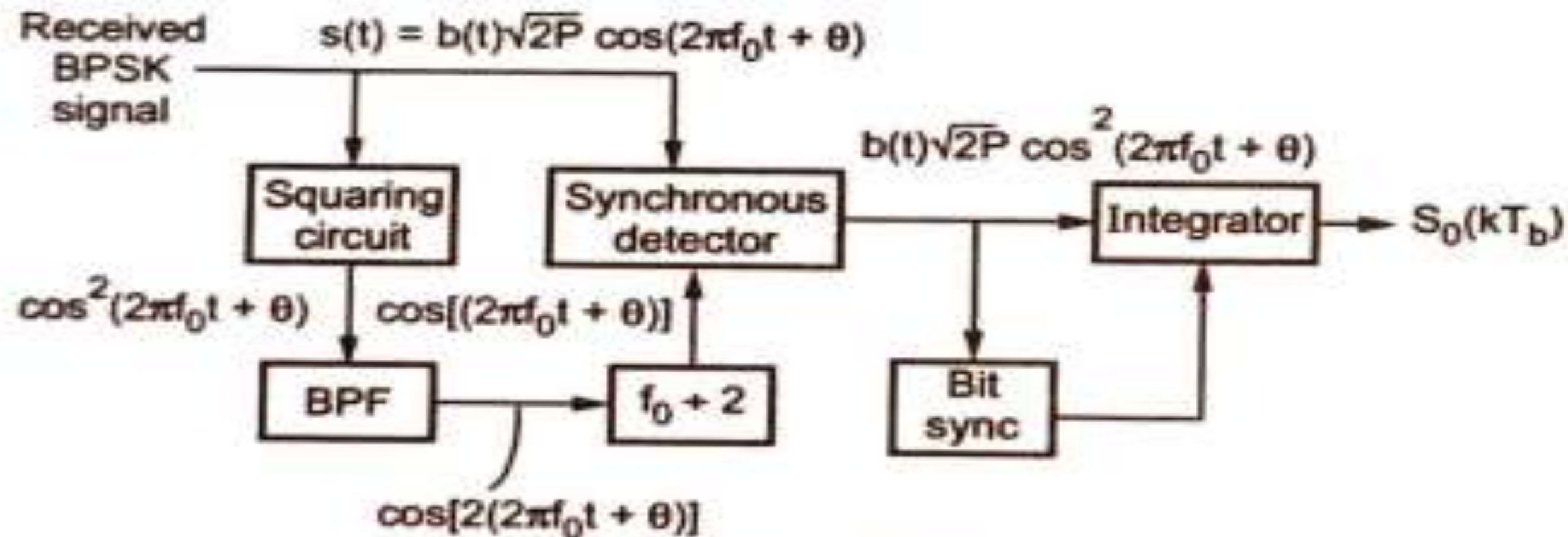

Fig. 4.7.3 Reception BPSK scheme



BPSK - Receiver



Operation of the receiver

1) **Phase shift in received signal** : This signal undergoes the phase change depending upon the time delay from transmitter to receiver. This phase change is normally fixed phase shift in the transmitted signal. Let the phase shift be θ . Therefore the signal at the input of the receiver is,

2) **Squaring circuit** : Now from this received signal, a carrier is separated since this is coherent detection. As shown in the Fig. 4.7.3, the received signal is passed through a square law device. At the output of the square law device the signal will be,

$$\cos^2 (2\pi f_0 t + \theta)$$

Note here that we have neglected the amplitude, because we are only interested in the carrier of the signal.



BPSK - Receiver



We know that,

$$\cos^2 \theta = \frac{1 + \cos 2\theta}{2}$$

$$\therefore \cos^2 (2\pi f_0 t + \theta) = \frac{1 + \cos 2(2\pi f_0 t + \theta)}{2}$$

or
$$= \frac{1}{2} + \frac{1}{2} \cos 2(2\pi f_0 t + \theta)$$

Here $\frac{1}{2}$ represents a D.C. level.

3) **Bandpass filter (BPF)** : This signal is then passed through a bandpass filter whose passband is centered around $2f_0$. Bandpass filter removes the D.C. level of $\frac{1}{2}$ and

at its output we get,

$$\cos 2(2\pi f_0 t + \theta)$$

This signal has frequency of $2f_0$.



BPSK - RECEIVER



$$\cos 2(2\pi f_0 t + \theta)$$

4) **Frequency divider ($f_0 + 2$)** : The above signal is passed through a frequency divider by two. Therefore at the output of frequency divider we get a carrier signal whose frequency is f_0 i.e. $\cos(2\pi f_0 t + \theta)$.

5) **Synchronous demodulator** : The synchronous (coherent) demodulator multiplies the input signal and the recovered carrier. Therefore at the output of multiplier we get,

$$\begin{aligned} b(t) \sqrt{2P} \cos(2\pi f_0 t + \theta) \times \cos(2\pi f_0 t + \theta) &= b(t) \sqrt{2P} \cos^2(2\pi f_0 t + \theta) \\ &= b(t) \sqrt{2P} \times \frac{1}{2} [1 + \cos 2(2\pi f_0 t + \theta)] \\ &= b(t) \sqrt{\frac{P}{2}} [1 + \cos 2(2\pi f_0 t + \theta)] \quad \dots (4.7.8) \end{aligned}$$

6) **Bit synchronizer and integrator** : The above signal is then applied to the bit synchronizer and integrator. The integrator integrates the signal over one bit period. The bit synchronizer takes care of starting and ending times of a bit.



BPSK - Generator



4.7.6 Bandwidth of BPSK Signal

The spectrum of the BPSK signal is centered around the carrier frequency f_0 .

If $f_b = \frac{1}{T_b}$, then for BPSK the maximum frequency in the baseband signal will be

f_b see Fig. 4.7.6. In this Fig. 4.7.6 the main lobe is centered around carrier frequency f_0 and extends from $f_0 - f_b$ to $f_0 + f_b$. Therefore Bandwidth of BPSK signal is,

$$\begin{aligned} BW &= \text{Highest frequency} - \text{Lowest frequency in the main lobe} \\ &= f_0 + f_b - (f_0 - f_b) \end{aligned}$$

\therefore

$$BW = 2f_b$$

... (4.7.21)

Thus the minimum bandwidth of BPSK signal is equal to twice of the highest frequency contained in baseband signal.



THANK YOU