



SNS COLLEGE OF TECHNOLOGY

Coimbatore-35
An Autonomous Institution



Accredited by NBA – AICTE and Accredited by NAAC – UGC with 'A++' Grade
Approved by AICTE, New Delhi & Affiliated to Anna University, Chennai

DEPARTMENT OF ELECTRONICS & COMMUNICATION ENGINEERING

19ECB202 – LINEAR AND DIGITAL CIRCUITS

II YEAR/ III SEMESTER

UNIT 2 – COMPARATORS AND SPECIAL FUNCTION IC's

TOPIC 4 - IC Voltage regulators - Three terminal fixed and

Adjustable voltage Regulators



IC Voltage regulators



- A voltage regulator is one of the most widely used electronic circuitry in any device.
- A regulated voltage (without fluctuations & noise levels) is very important for the smooth functioning of many digital electronic devices.
- A common case is with micro controllers, where a smooth regulated input voltage must be supplied for the micro controller to function smoothly



IC Voltage regulators



- An IC based voltage regulator can be classified in different ways.
- A common type of classification is 3 terminal voltage regulator and 5 or multi terminal voltage regulator.
- Another popular way of classifying IC voltage regulators is by identifying them as linear voltage regulator & switching voltage regulator.
- There is a third set of classification as
 - 1) Fixed voltage regulators (positive & negative)
 - 2) Adjustable voltage regulators (positive & negative) and finally
 - 3) Switching regulators.
- In the third classification, fixed & adjustable regulators are basically versions of linear voltage regulators.



Block diagram of IC Voltage regulators



BLOCK DIAGRAM OF IC VOLTAGE REGULATOR

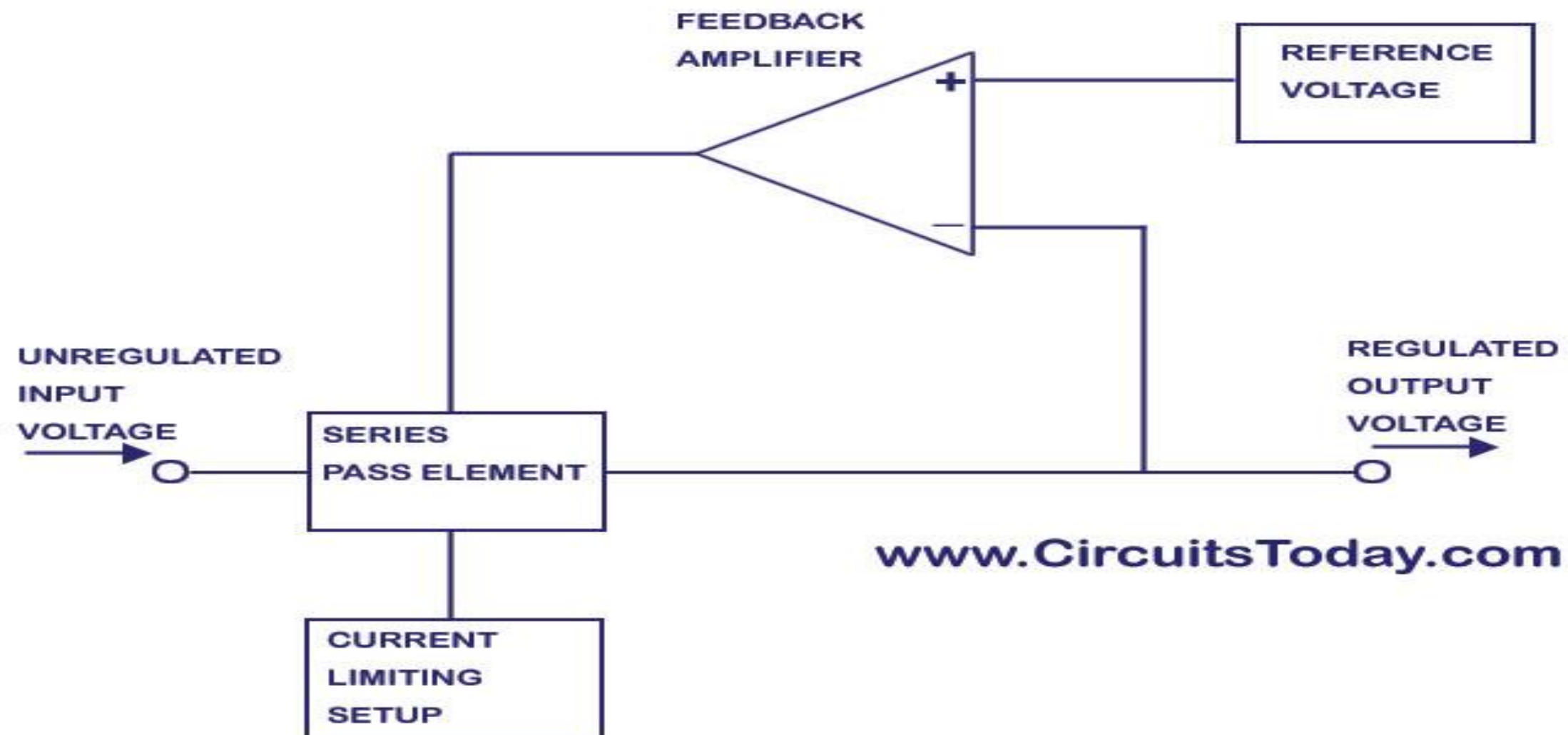



Why three terminal fixed voltage Regulators are Preferred?



- Three Terminal Voltage Regulator is IC based voltage regulator designed with fixed output voltage value without any external feedback elements.



eg

- 7805 IC is three terminal voltage regulator which regulates the output voltage at 5 volts for the unregulated input voltage ranging from 7V to 25V.





Three terminal fixed voltage Regulators are Preferred?

- As the name suggests, three terminal voltage regulators have three terminals namely input which is unregulated (V_{in}), regulated output (V_o) and common or a ground terminal.
- These regulators do not require any feedback connections. Figure shows the basic the 3 terminal voltage regulator.

IC Voltage regulators/19ECB202 - LINEAR
AND DIGITAL
CIRCUITS/Mrs.R.Prabha/AP/ECE/SNSCT

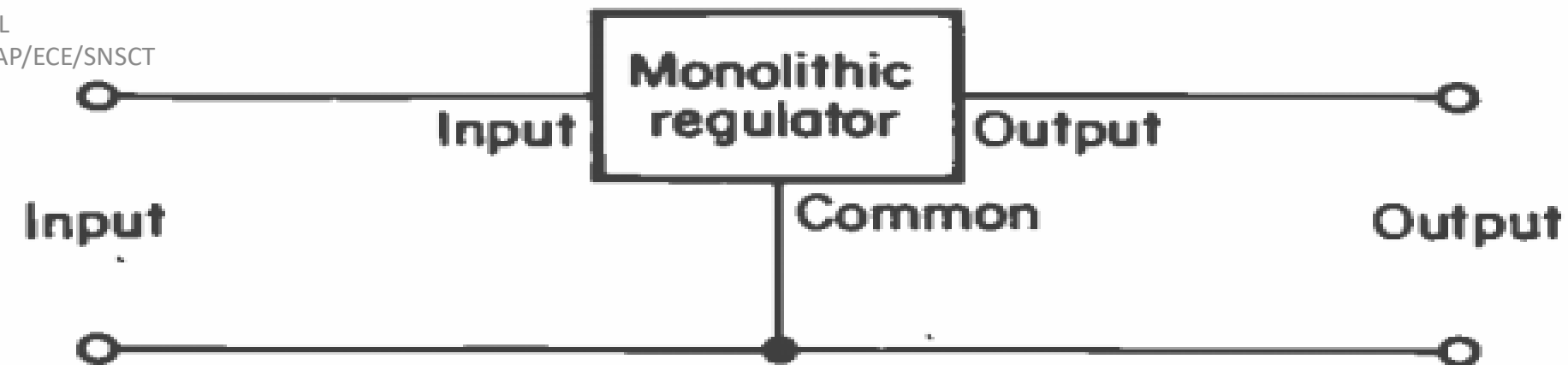

08/10/2023



Three terminal fixed voltage regulators



- The three terminals of the IC are for apparent reasons, designated with the names **input, common and output**.
- The supply positive and negative are simply connected across the input and common terminals of the IC respectively, while the regulated stabilized voltage is acquired across the output and common terminals.



08/10/2023

IC Voltage regulators/19EC0202 - LINEAR
AND DIGITAL
CIRCUITS/Mrs.R.Prabha/AP/ECE/SNSCT



Three terminal fixed voltage regulators

Types

78XX series positive regulators.

79XX series negative regulators.

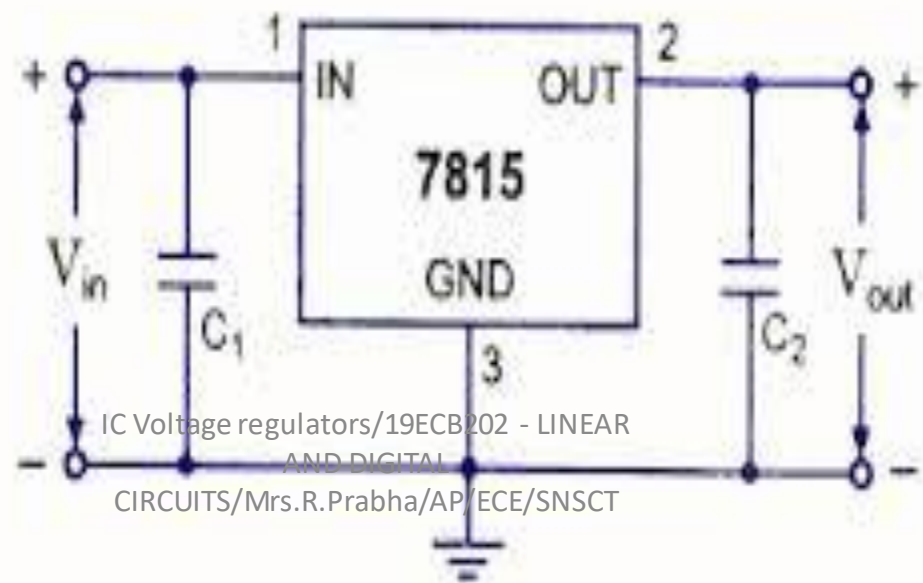

Connection of 7815 Voltage Regulator

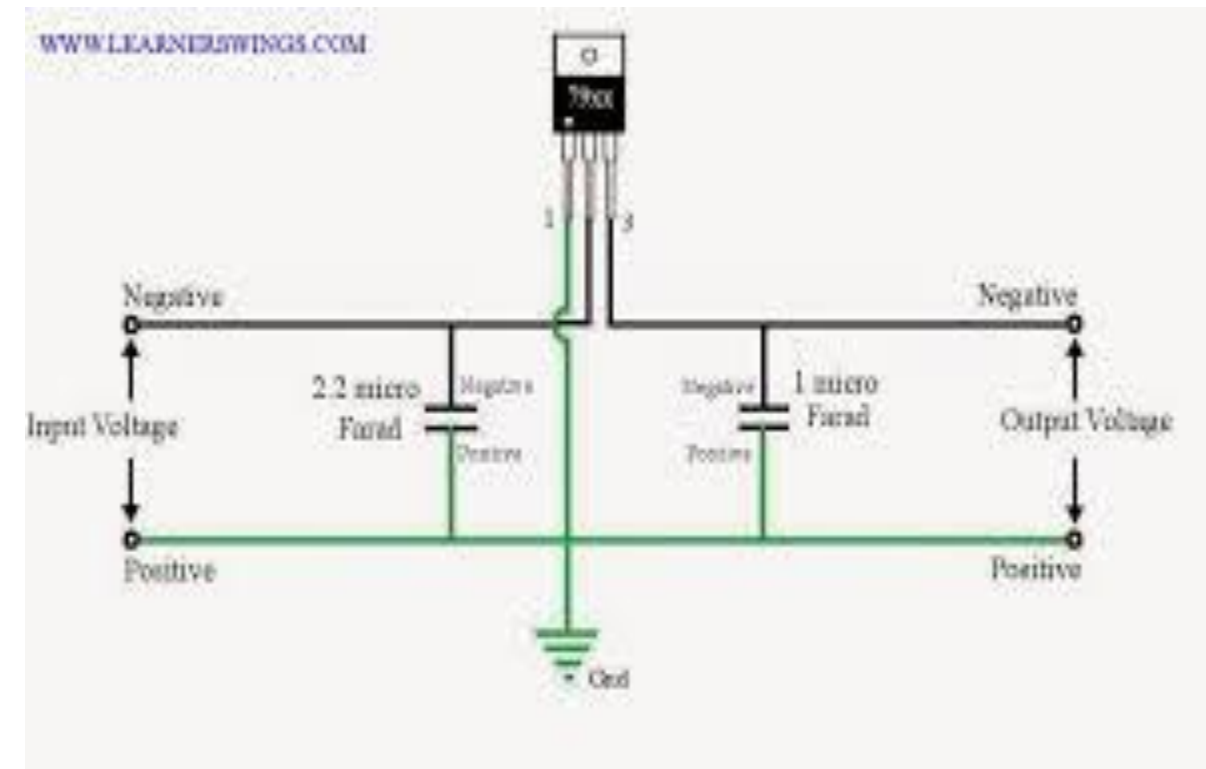



Three terminal fixed voltage regulators

Applications of IC 78XX and 79XX

➤ These ICs are regulator ICs and are basically used to provide constant d.c. voltages to various components in complex electronic circuits.



IC Voltage regulators/19CE202 - LINEAR AND DIGITAL CIRCUITS/Mrs.R.Prerna/Asp/ECE/SNSCT

08/10/2023

➤ The IC 7805 is typically used to provide constant 5V supply to the digital circuits.

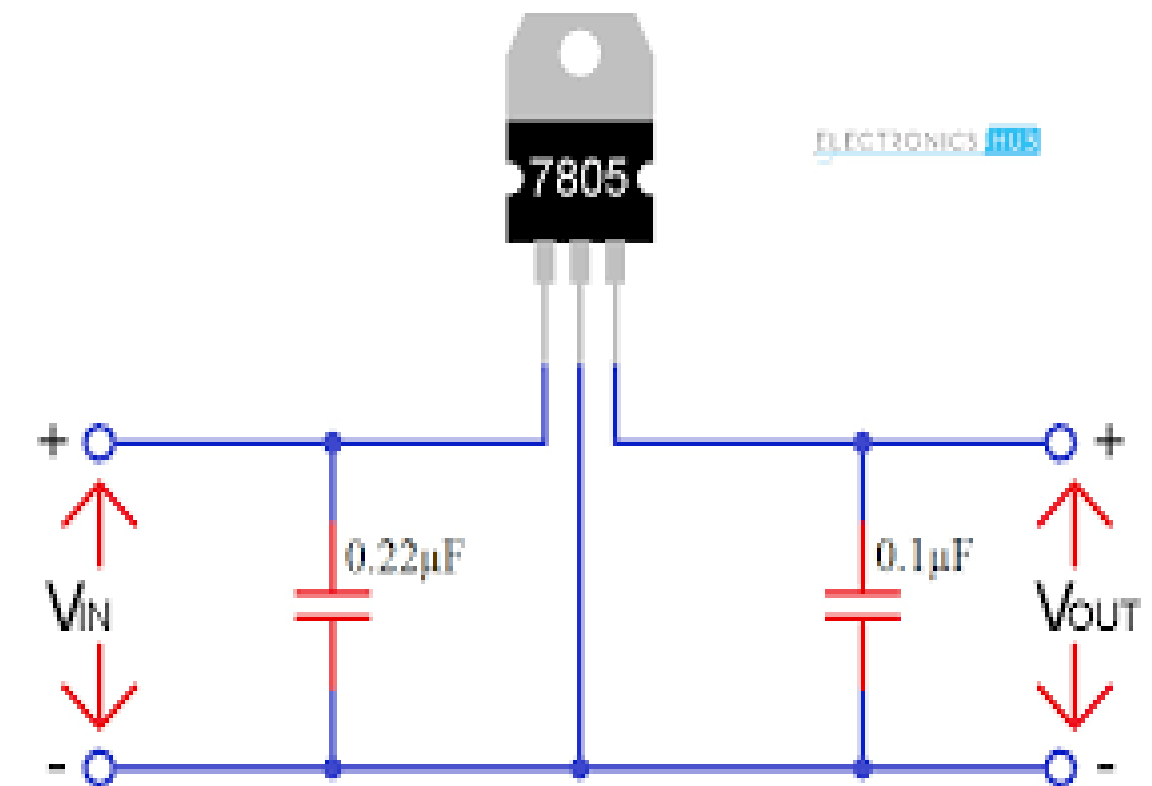



Three terminal Adjustable voltage regulators



- An adjustable voltage regulator is a kind of regulator whose regulated output voltage can be varied over a range.
- There are two variations of the same, known as positive adjustable voltage regulator and negative adjustable regulator.
- LM317 is a classic example of positive adjustable voltage regulator, whose output voltage can be varied over a range of 1.2 volts to 57 volts.
- LM337 is an example of negative adjustable voltage regulator.

08/10/2023

IC Voltage regulators/19ECB202 - LINEAR
AND DIGITAL
CIRCUITS/Mrs.Prabha/AP/ECE/SNSCT



Three terminal Adjustable voltage regulators



- LM337 is actually a complement of LM317 which are similar in operation & design, with the only difference being polarity of regulated output voltage.
- There may be certain conditions where a variable voltage may be required. Right now we shall discuss how an LM317 adjustable positive voltage regulator IC is connected.

IC Voltage regulators/19ECB202 - LINEAR
AND DIGITAL
CIRCUITS/Mrs.R.Prabha/AP/ECE/SNSCT

08/10/2023



Three terminal Adjustable voltage regulators



ADJUSTABLE VOLTAGE REGULATOR USING LM 317

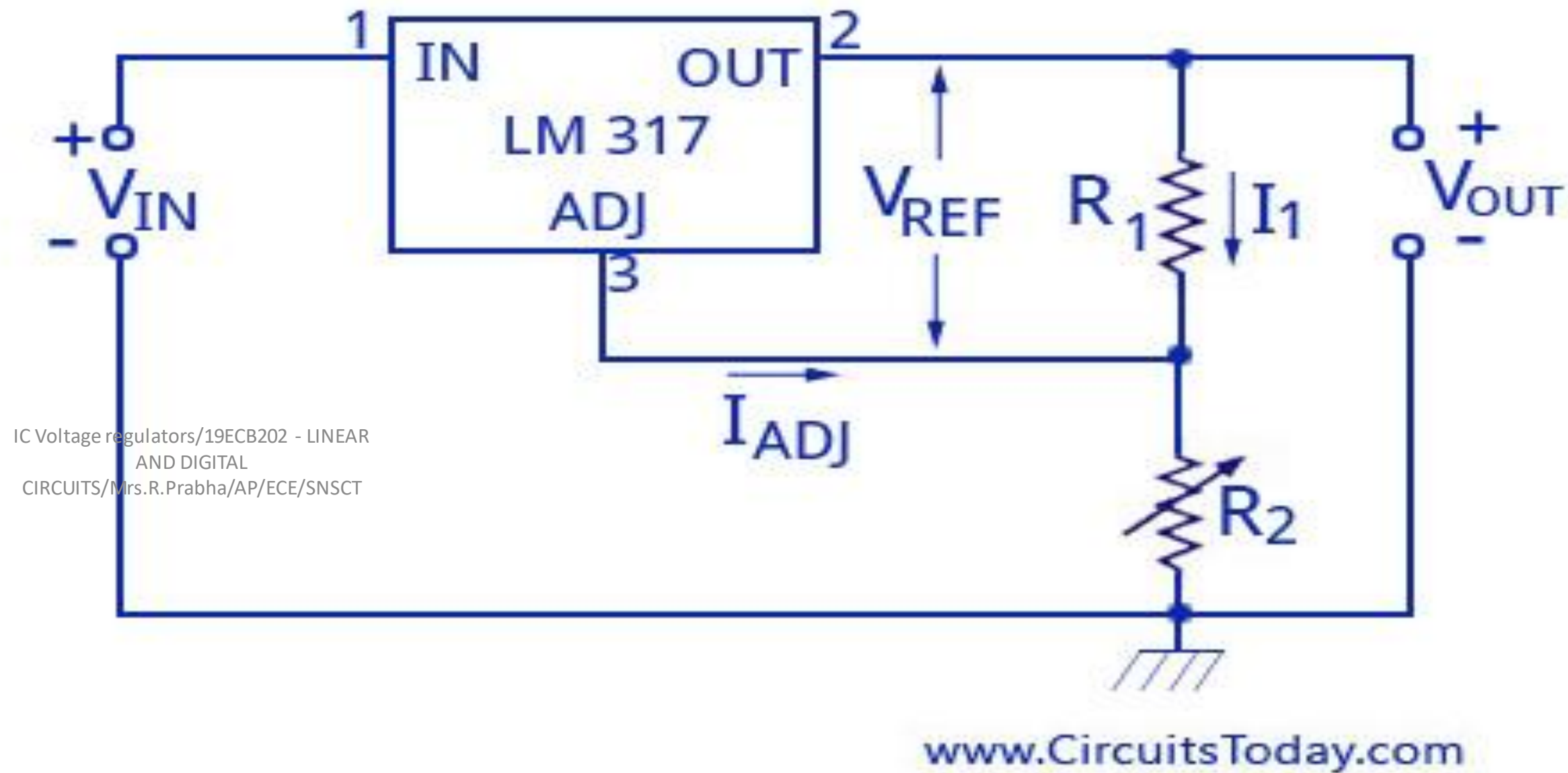

08/10/2023



Three terminal Adjustable voltage regulators



- The resistors R1 and R2 determine the output voltage V_{out} . The resistor R2 is adjusted to get the output voltage range between 1.2 volts to 57 volts.
- The output voltage that is required can be calculated using the equation
- $V_{out} = V_{ref} (1 + R2/R1) + I_{adj} R2$ In this circuit, the value of V_{ref} is the reference voltage between the adjustment terminals and the output taken as 1.25 Volt.
- The value of I_{adj} will be very small and will also have a constant value.

IC Voltage regulators/19ECB202 - LINEAR
AND DIGITAL
CIRCUITS/Mrs.R.Prabha/AP/ECE/SNSCT

08/10/2023



Three terminal Adjustable voltage regulators



- Thus the above equation can be rewritten as $V_{out} = 1.25 (1 + R_2/R_1)$ In the above equation, due to the small value of I_{adj} , the drop due to R_2 is neglected.
- The load regulation is 0.1 percent while the line regulation is 0.01 percent per volt. This means that the output voltage varies only 0.01 percent for each volt of input voltage.
- The ripple rejection is 80 db, equivalent to 10,000. The LM 337 series of adjustable voltage regulators is a complement to the LM 317 series devices.
- The negative adjustable voltage regulators are available in the same voltage and current options as the LM 317 devices.

08/10/2023

IC Voltage regulators/19ECB202 - LINEAR
AND DIGITAL
CIRCUITS/Mrs.B.Prasanna/ASP/ECE/SNSCT



Three terminal Adjustable voltage regulators



- Besides fixed voltage regulators, IC voltage regulators are available which allow the adjustment of the output voltage.
- The output voltage can be adjusted from 1.2 V to as high as 57 V with the help of such regulators.

IC Voltage regulators/19ECB202 - LINEAR
AND DIGITAL
CIRCUITS/Mrs.R.Prabha/AP/ECE/SNSCT

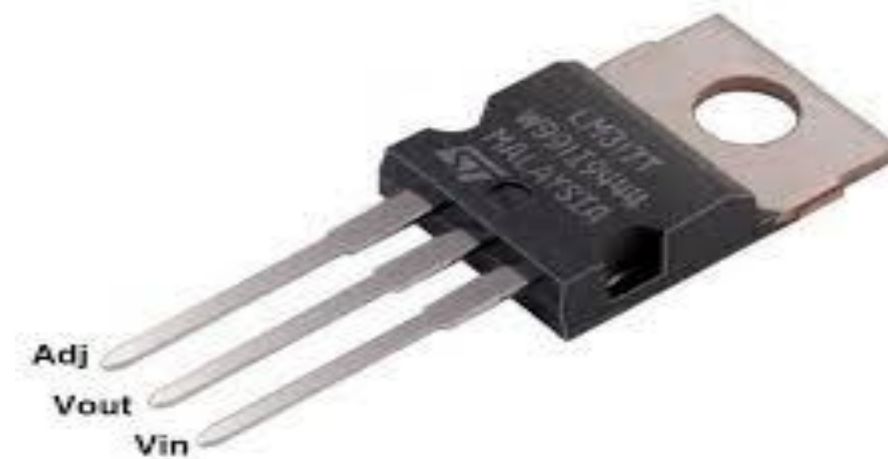



Three terminal Adjustable voltage regulators



- In such regulator ICs the common terminal plays the role of control input and hence called and ADJUSTMENT (ADJ) terminal.
- The LM317 series is the most commonly used three terminal adjustable regulators. These devices are available in a variety of packages which can be easily mounted and handled. The power rating of such regulators is 1.5 A.
- The maximum input voltage of LM317 is 40V.

IC Voltage regulators/19ECB202 - LINEAR
AND DIGITAL
CIRCUITS/Mrs.R.Prabha/AP/ECE/SNSCT

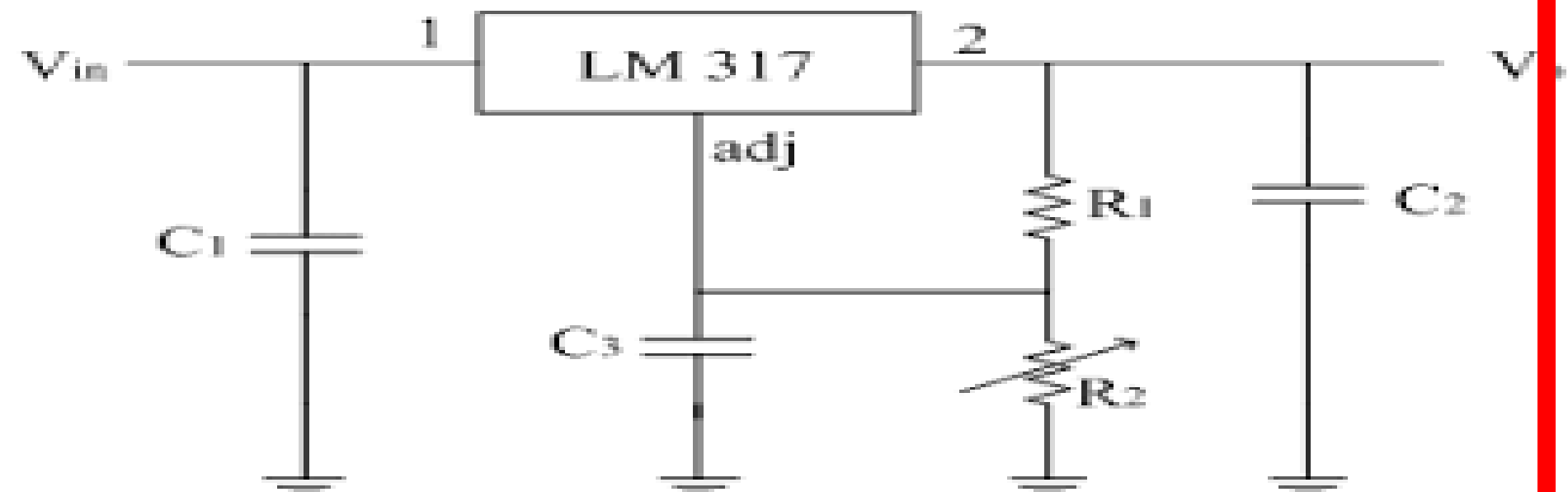



Three terminal Adjustable voltage regulators

Applications

- Improved line and load regulation by a factor of 10 or more.
- Because of improved overload protection, greater load current can be drawn over the given operating temperature range.
- Improved reliability for the power supply using these regulators.

IC Voltage regulators/19ECB202 - LINEAR AND DIGITAL CIRCUITS/Mrs.R.Prabha/AP/ECE/SNSCT

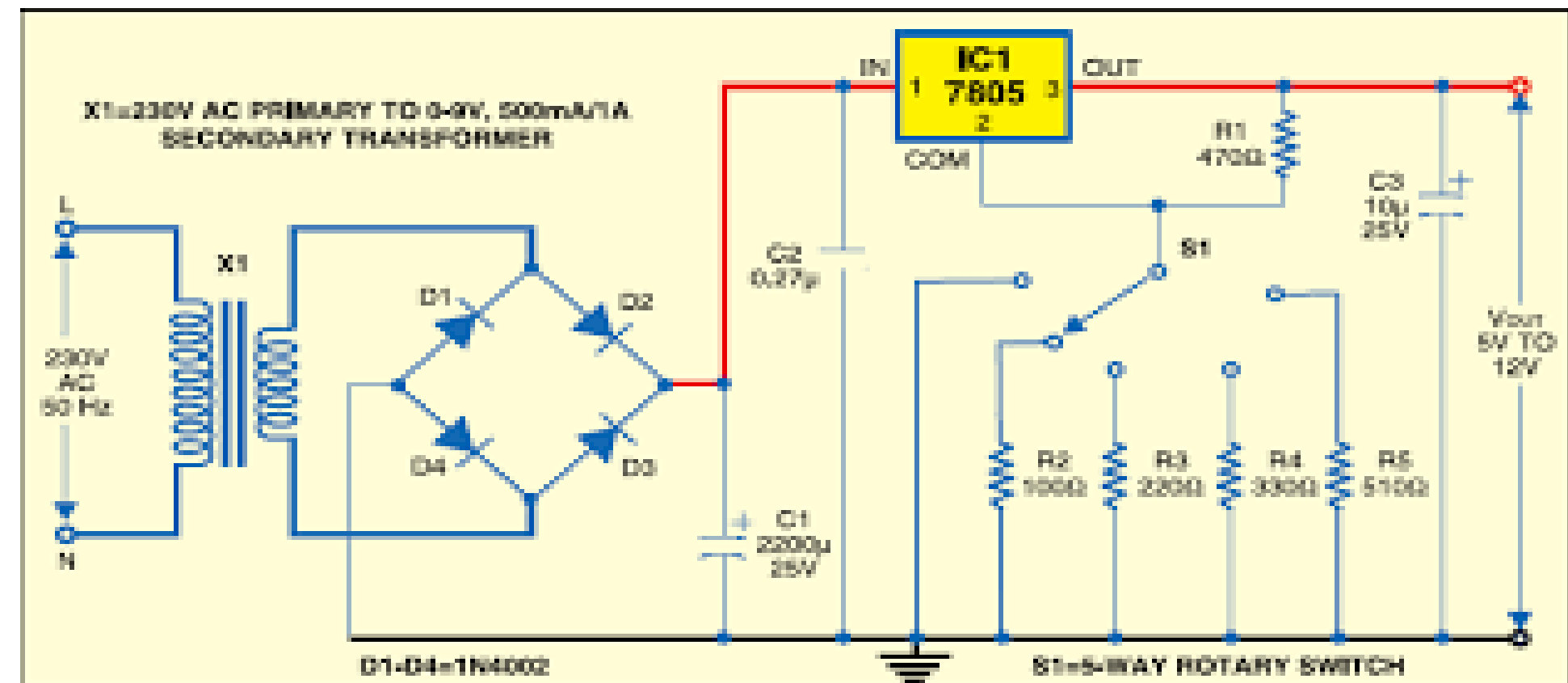

Three Terminal fixed and Adjustable Voltage Regulators / 19ECB202 / Linear and



Three terminal Adjustable voltage regulators

Limitations of Linear Voltage Regulators

- The required input step down transformer is bulky and expensive.
- Due to low line frequency (50 Hz), large values of filter capacitors are required.
- The efficiency is very low. 4. Input must be greater than the output voltage.

IC Voltage regulators/19ECB202 - LINEAR
AND DIGITAL
CIRCUITS/Mrs.R.Prabha/AP/ECE/SNSCT

08/10/2023



Three terminal Adjustable voltage regulators

Limitations of Linear Voltage Regulators

- As large is the difference between input and output voltage, more is the power dissipation in the series pass transistor.
- For higher input voltages, efficiency decreases.
- The need for dual supply is not economical and feasible to achieve with the help of linear regulators.
- The switching regulators overcome all these limitations.

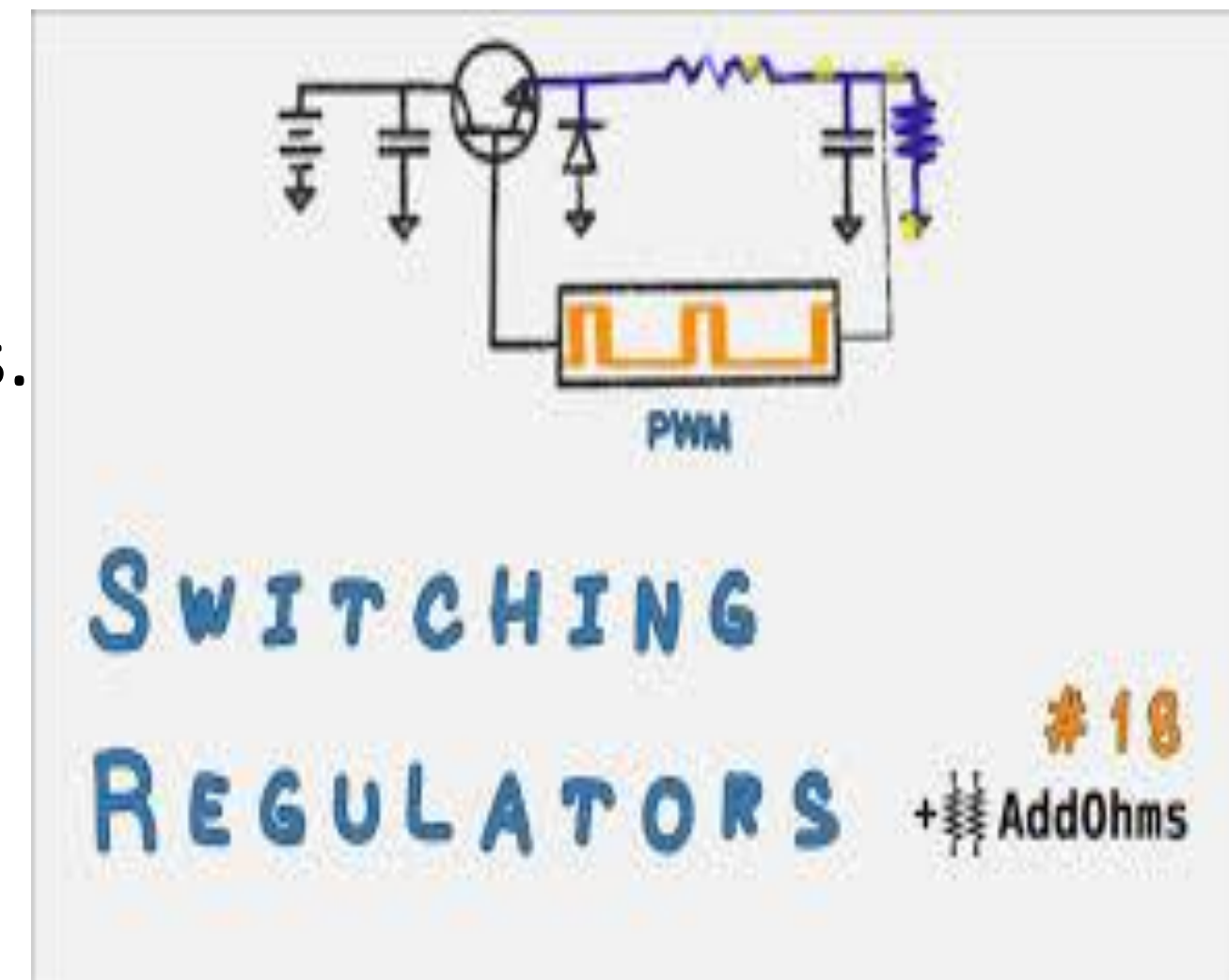



THANK YOU