



SNS COLLEGE OF TECHNOLOGY

Coimbatore-35
An Autonomous Institution



Accredited by NBA – AICTE and Accredited by NAAC – UGC with 'A++' Grade
Approved by AICTE, New Delhi & Affiliated to Anna University, Chennai

DEPARTMENT OF ELECTRONICS & COMMUNICATION ENGINEERING

19ECB241 DIGITAL ELECTRONICS

II YEAR/ III SEMESTER

UNIT-II COMBINATIONAL CIRCUITS

Topic 7– Parity Generator and Parity Check



Parity Generator



The parity generating technique is one of the most widely used error detection techniques for the data transmission. In digital systems, when binary data is transmitted and processed, data may be subjected to noise so that such noise can alter 0s (of data bits) to 1s and 1s to 0s.

A parity generator is a combinational logic circuit that generates the parity bit in the transmitter. On the other hand, a circuit that checks the parity in the receiver is called parity checker. A combined circuit or devices of parity generators and parity checkers are commonly used in digital systems to detect the single bit errors in the transmitted data word.



Parity Generator



It is combinational circuit that accepts an $n-1$ bit stream data and generates the additional bit that is to be transmitted with the bit stream. This additional or extra bit is termed as a parity bit.

- In even parity bit scheme, the parity bit is '0' if there are even number of 1s in the data stream and the parity bit is '1' if there are odd number of 1s in the data stream.
- In odd parity bit scheme, the parity bit is '1' if there are even number of 1s in the data stream and the parity bit is '0' if there are odd number of 1s in the data stream. Let us discuss both even and odd parity generators.



Even Parity Generator

3-bit message			Even parity bit generator (P)
A	B	C	Y
0	0	0	0
0	0	1	1
0	1	0	1
0	1	1	0
1	0	0	1
1	0	1	0
1	1	0	0
1	1	1	1



Even Parity Generator



A \ BC	00	01	11	10
00	0	1	0	1
01	1	0	1	0

The table above is a Karnaugh map for an even parity generator. The rows represent the input variable A (00 and 01) and the columns represent the input variables B and C (00, 01, 11, 10). The output values are 0 or 1, with the 1s circled. The cells are numbered 0 through 7. A watermark 'ELECTRONICS HUB3' is visible across the table.



8-bit Word Comparator



$$P = \bar{A} \bar{B} C + \bar{A} B \bar{C} + A \bar{B} \bar{C} + A B C$$

$$= \bar{A} (\bar{B} C + B \bar{C}) + A (\bar{B} \bar{C} + B C)$$

$$= \bar{A} (B \oplus C) + A (\overline{B \oplus C})$$

$$P = A \oplus B \oplus C$$

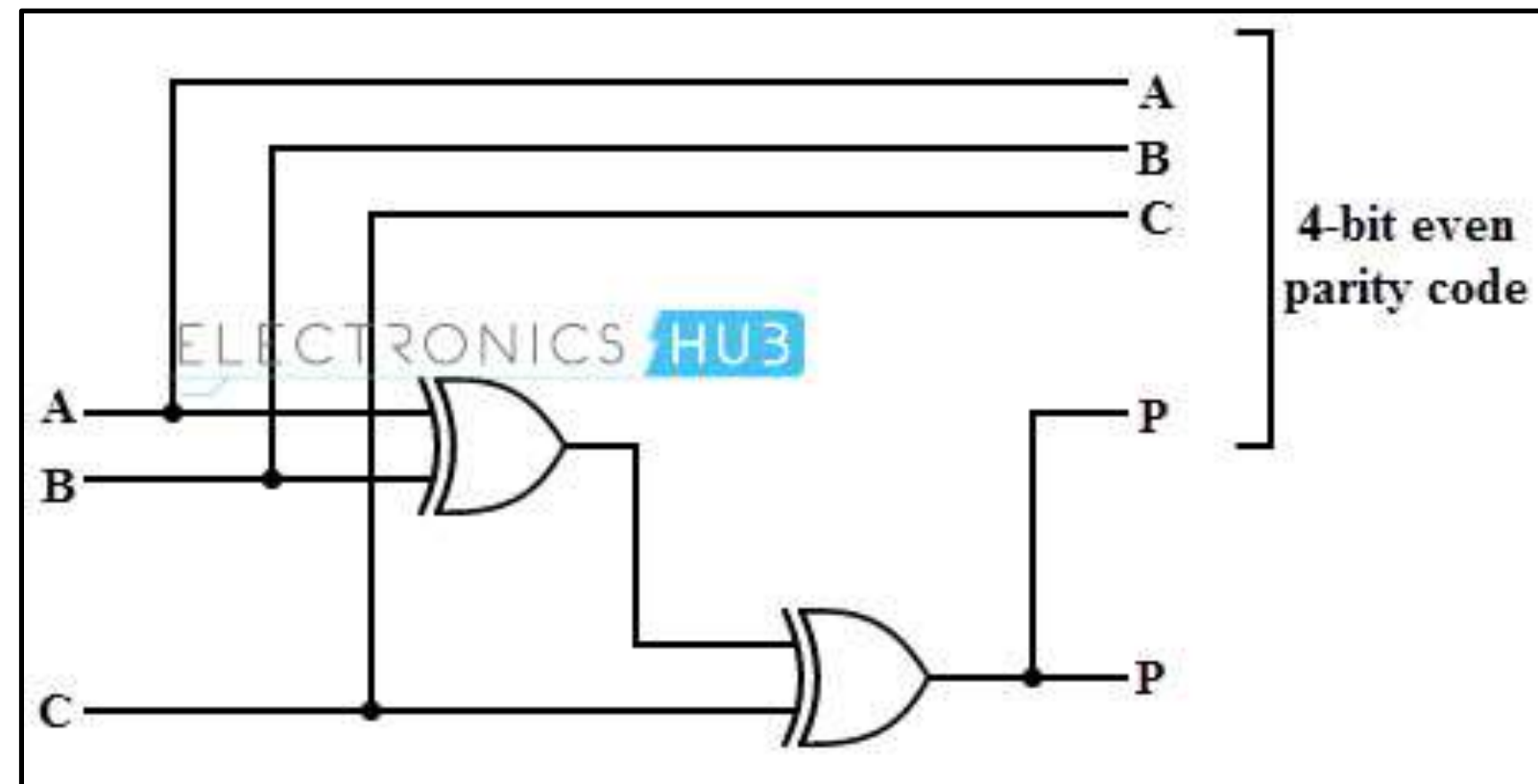



Odd Parity Generator



3-bit message			Odd parity bit generator (P)
A	B	C	Y
0	0	0	1
0	0	1	0
0	1	0	0
0	1	1	1
1	0	0	0
1	0	1	1
1	1	0	1
1	1	1	0



Odd Parity Generator



A \ BC	00	01	11	10
00	0	1	3	2
	1	0	1	0
01	4	5	7	6
	0	1	0	1



Odd Parity Generator

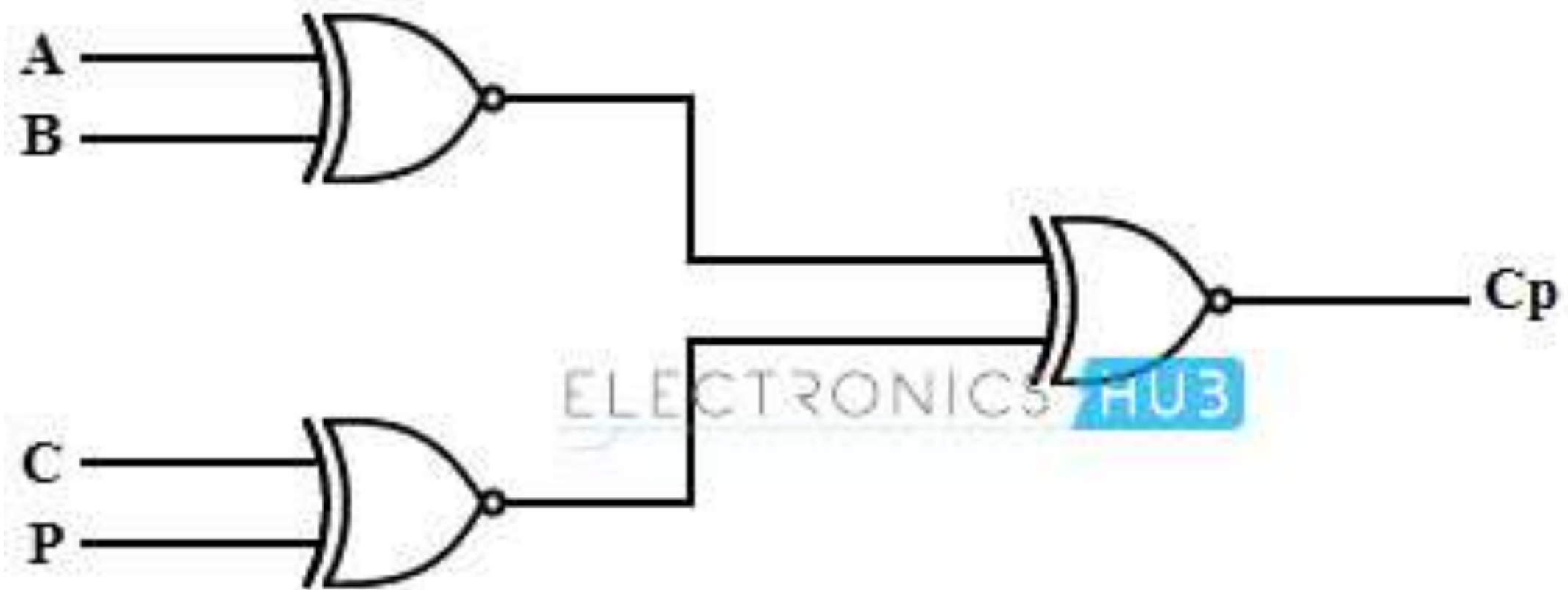



Odd Parity Checker



4-bit received message				Parity error check C_p
A	B	C	P	
0	0	0	0	1
0	0	0	1	0
0	0	1	0	0
0	0	1	1	1
0	1	0	0	0
0	1	0	1	1
0	1	1	0	1
0	1	1	1	0
1	0	0	0	0
1	0	0	1	1
1	0	1	0	1
1	0	1	1	0
1	1	0	0	1
1	1	0	1	0
1	1	1	0	0
1	1	1	1	1



Even Parity Checker



4-bit received message				Parity error check C_p
A	B	C	P	
0	0	0	0	0
0	0	0	1	1
0	0	1	0	1
0	0	1	1	0
0	1	0	0	1
0	1	0	1	0
0	1	1	0	0
0	1	1	1	1
1	0	0	0	1
1	0	0	1	0
1	0	1	0	0
1	0	1	1	1
1	1	0	0	0
1	1	0	1	1
1	1	1	0	1
1	1	1	1	0



Assessment



- 1.What is Parity bit?
- 2.Difference between odd and even parity.
- 3.Design 3 bit odd parity generator.



THANK YOU