



SNS COLLEGE OF TECHNOLOGY

Coimbatore-35
An Autonomous Institution



Accredited by NBA – AICTE and Accredited by NAAC – UGC with 'A+' Grade
Approved by AICTE, New Delhi & Affiliated to Anna University, Chennai

DEPARTMENT OF ELECTRONICS & COMMUNICATION ENGINEERING

16EC231 – DIGITAL ELECTRONICS

II YEAR/ III SEMESTER

UNIT 2 – COMBINATIONAL CIRCUITS

TOPIC - Multiplexer

11/3/2023



What is a Multiplexer?



- Multiplexer is a combinational circuit that has maximum of 2^n data inputs, 'n' selection lines and single output line.
- One of these data inputs will be connected to the output based on the values of selection lines..

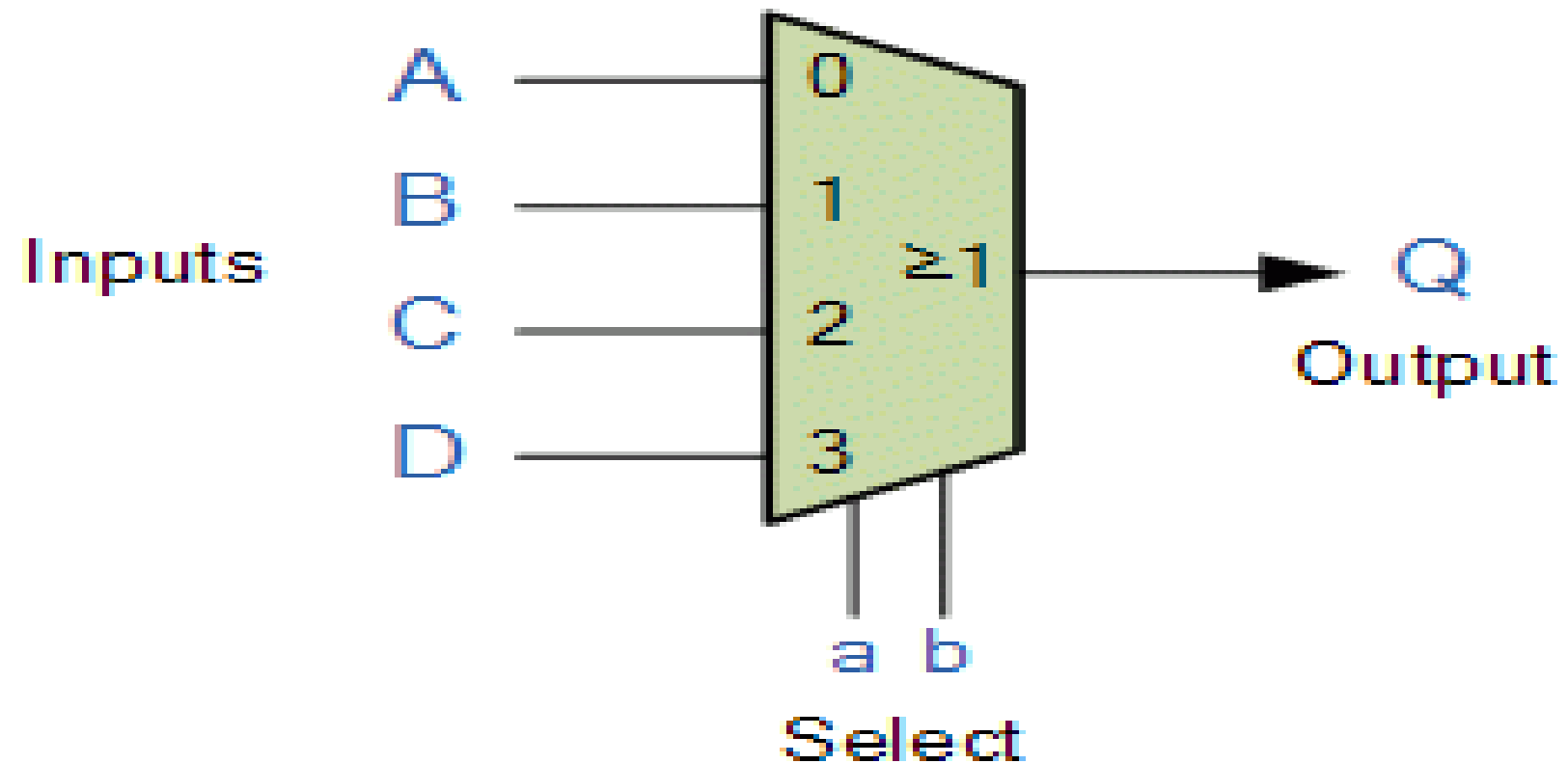
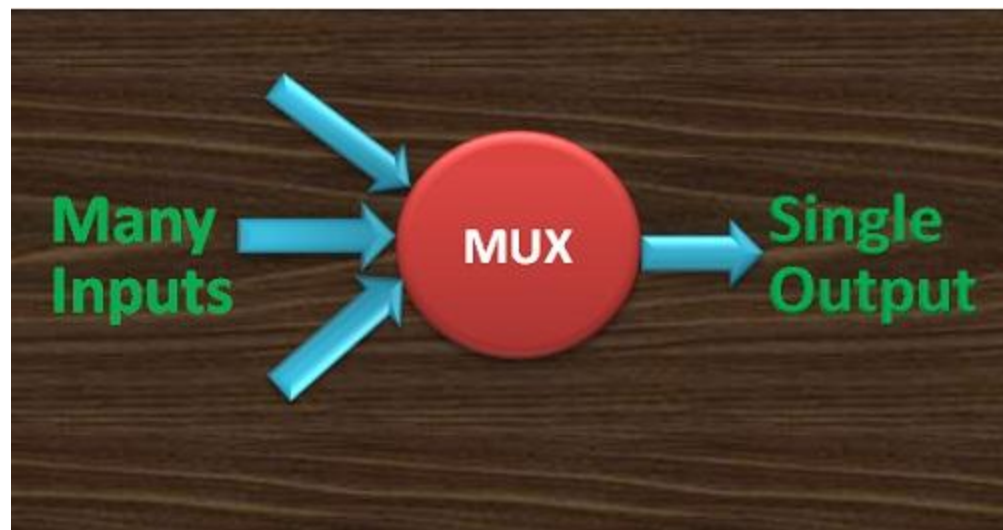

11/3/2023



4x1 Multiplexer



- 4x1 Multiplexer has four data inputs I_3 , I_2 , I_1 & I_0 , two selection lines s_1 & s_0 and one output Y .

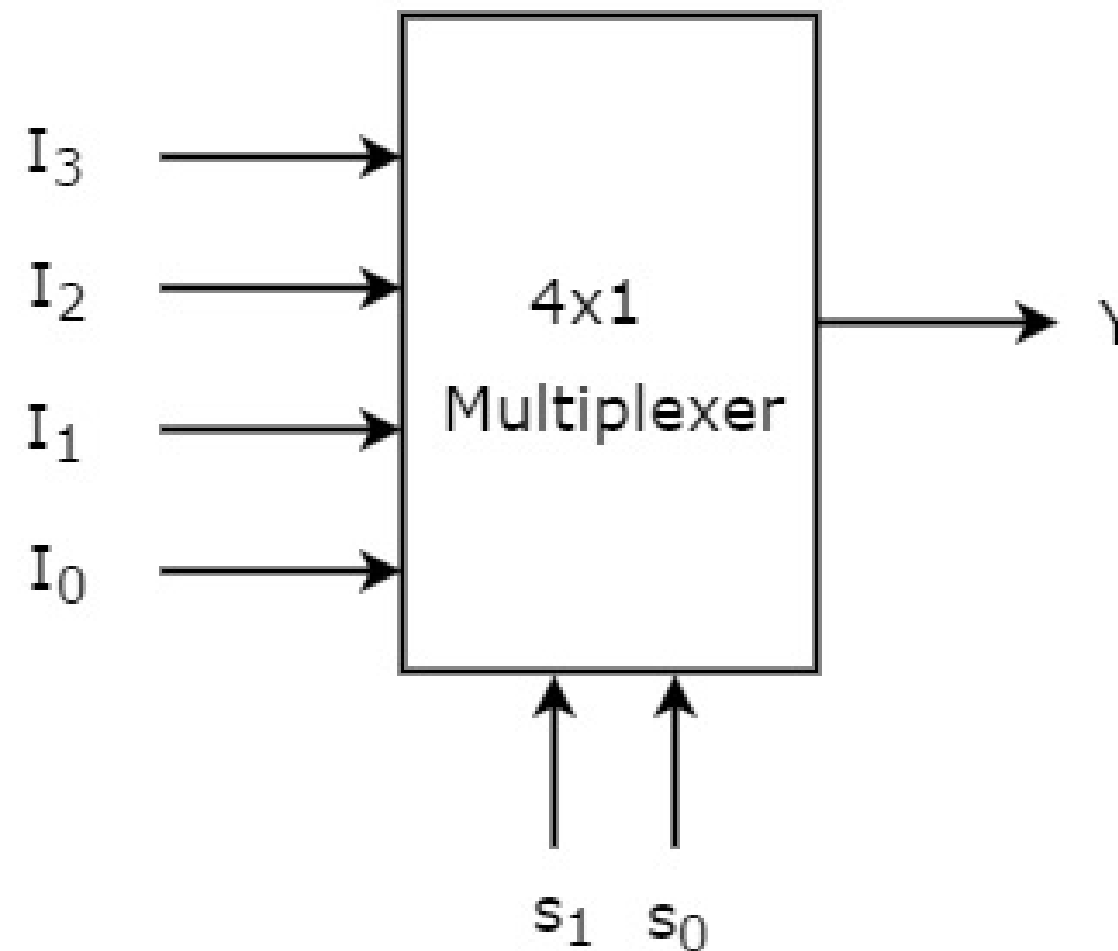



4x1 Multiplexer

- One of these 4 inputs will be connected to the output based on the combination of inputs present at these two selection lines.

Selection Lines		Output
S_1	S_0	Y
0	0	I_0
0	1	I_1
1	0	I_2
1	1	I_3

4x1 Multiplexer

➤ We can implement this Boolean function using Inverters, AND gates & OR gate.

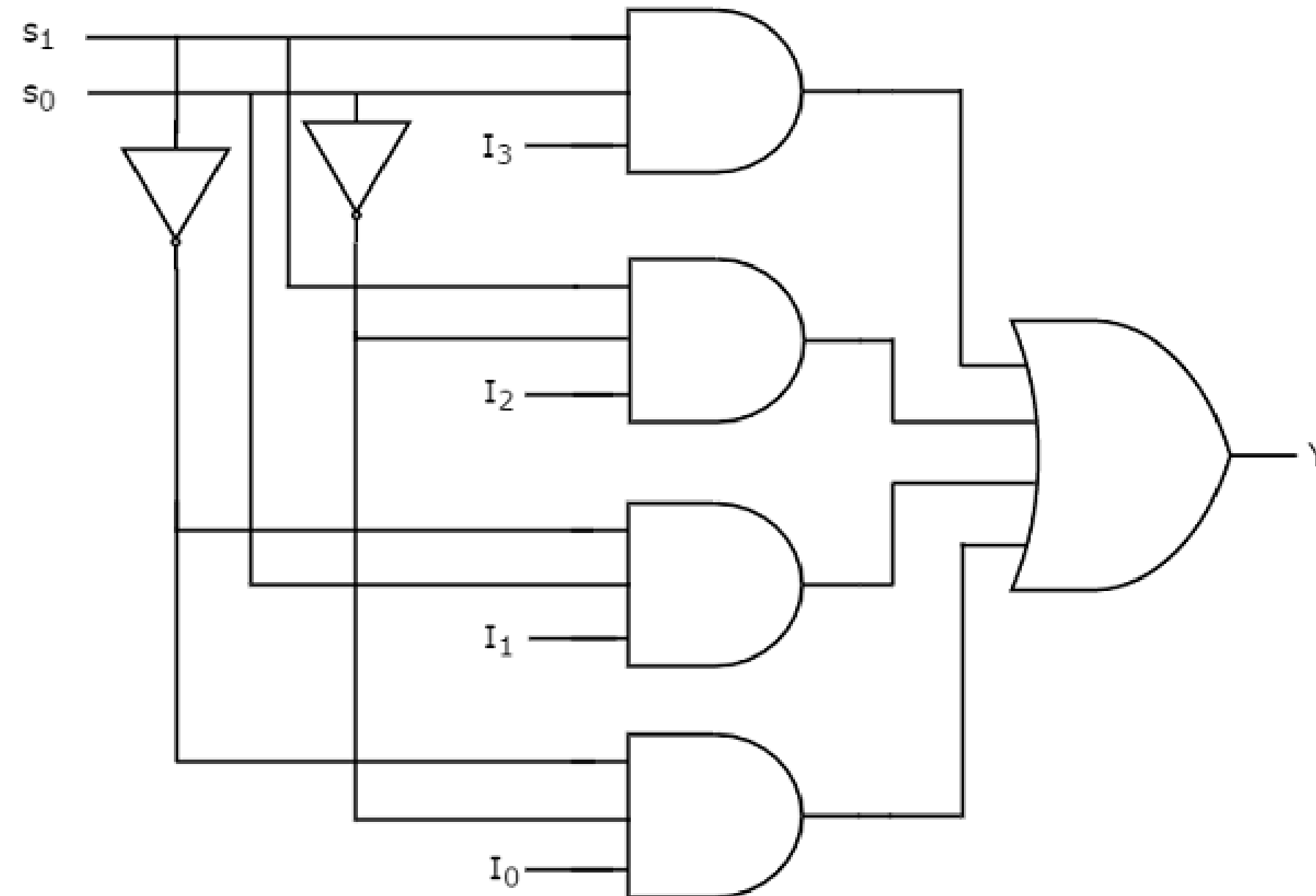



8x1 Multiplexer



- We require two 4x1 Multiplexers in first stage in order to get the 8 data inputs.

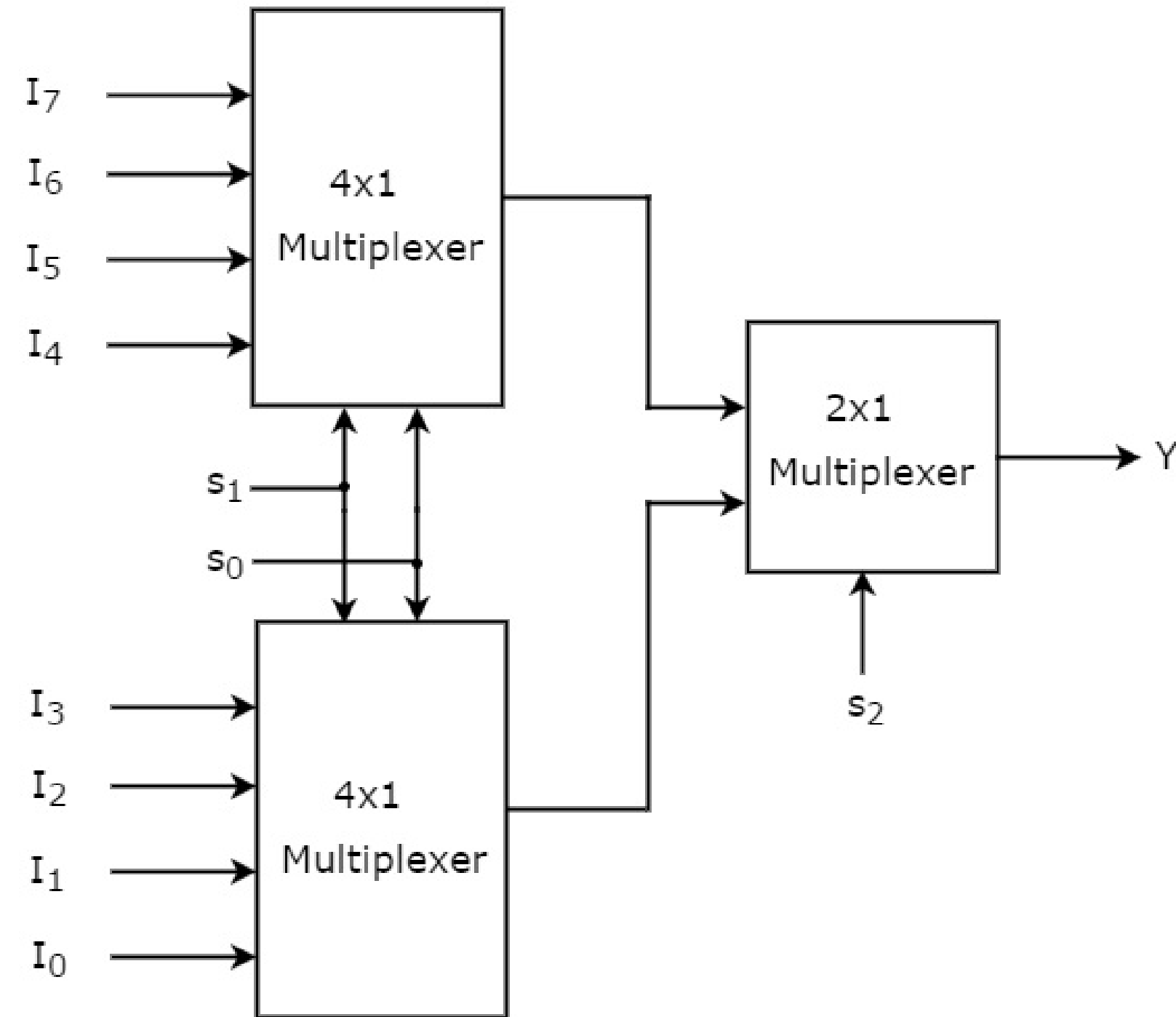



8x1 Multiplexer



➤ Let the 8x1 Multiplexer has eight data inputs I_0 to I_7 , three selection lines s_2 , s_1 & s_0 and one output Y

Selection Inputs			Output
s_2	s_1	s_0	Y
0	0	0	I_0
0	0	1	I_1
0	1	0	I_2
0	1	1	I_3
1	0	0	I_4
1	0	1	I_5
1	1	0	I_6
1	1	1	I_7

16x1 Multiplexer

➤ We require two 8x1 Multiplexers in first stage in order to get the 16 data inputs.

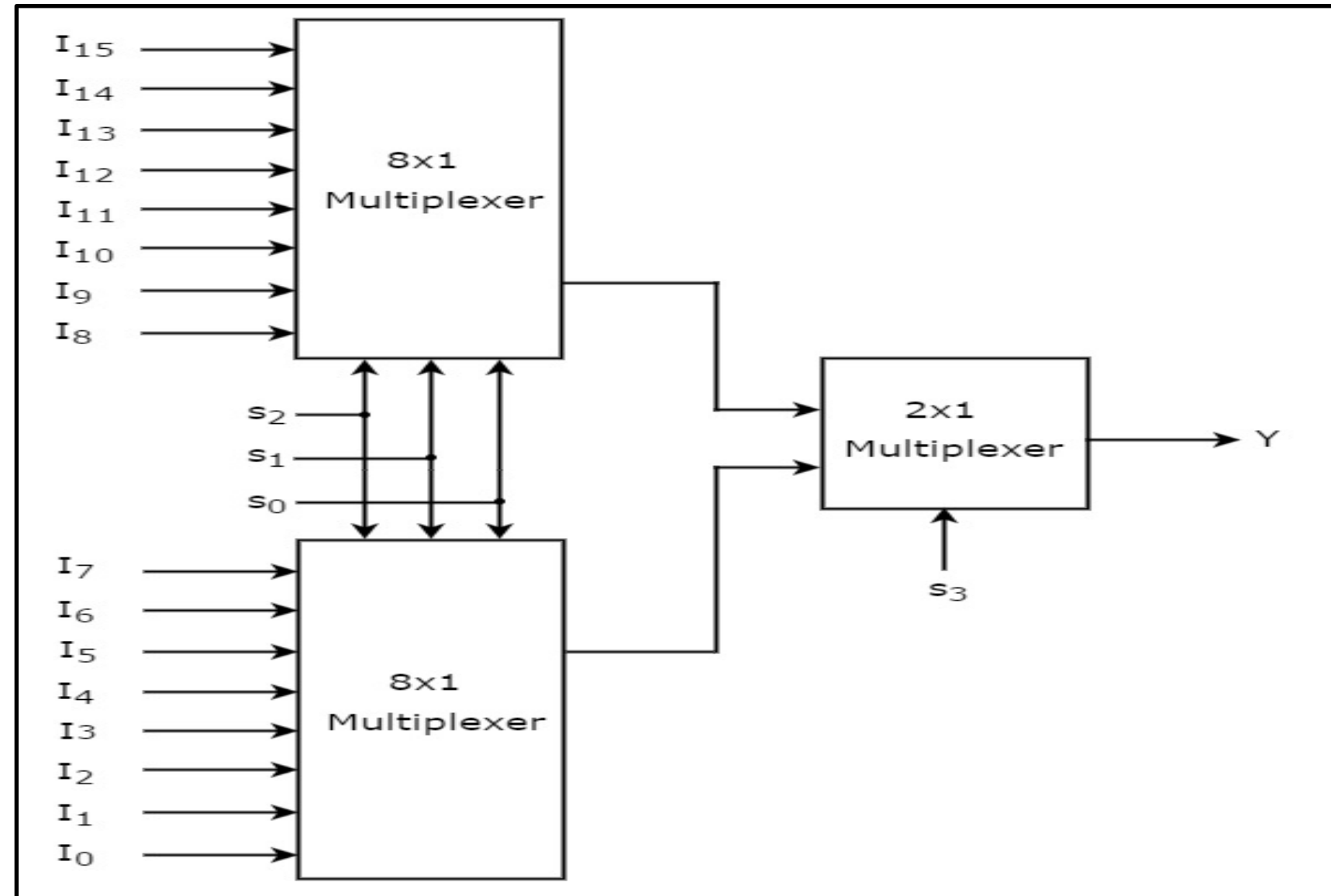



16x1 Multiplexer

- 16x1 Multiplexer has sixteen data inputs I_{15} to I_0 , four selection lines s_3 to s_0 and one output Y .

Selection Inputs				Output
s_3	s_2	s_1	s_0	Y
0	0	0	0	I_0
0	0	0	1	I_1
0	0	1	0	I_2
0	0	1	1	I_3
0	1	0	0	I_4
0	1	0	1	I_5
0	1	1	0	I_6
0	1	1	1	I_7
1	0	0	0	I_8

1	0	0	1	I_9
1	0	1	0	I_{10}
1	0	1	1	I_{11}
1	1	0	0	I_{12}
1	1	0	1	I_{13}
1	1	1	0	I_{14}
1	1	1	1	I_{15}



Advantages



Advantages :

- 1) It reduces number of wires .
- 2) It reduces circuit complexity and cost .
- 3) We can implement many combination circuits using MUX.
- 4) It does not need K maps and simplification .



Disadvantages



Disadvantages:

- 1) Added delays in switching ports .
- 2) Limitations on which ports can be used simultaneously .
- 3) Added firmware complexity to handle switching ports .
- 4) Added delays in I/O signals propagating through the multiplexer .
- 5) Extra I/O ports required to control the multiplexer.

Typical Application of a MUX

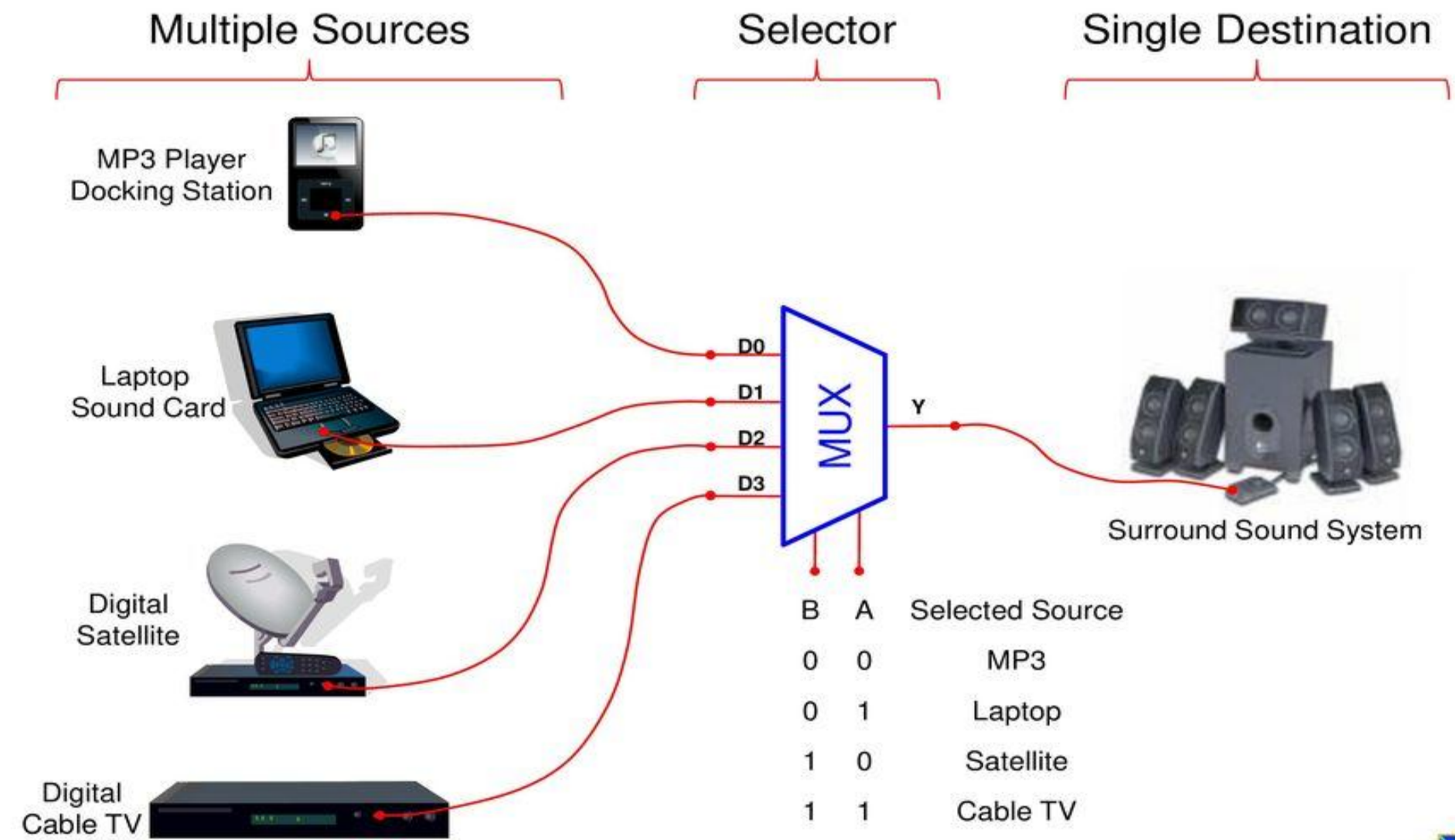

11/3/2023



ASSESSMENTS



1. What is Multiplexer?
2. Design 8:1 Multiplexer.
3. List the applications of multiplexer.

11/3/2023



THANK YOU

11/3/2023