

## Unit 6<sup>th</sup>

### SSC

#### **Data Acquisition System:**

A typical Data Acquisition System consists of individual sensors with the necessary signal conditioning, data conversion, data processing, multiplexing, data handling and associated transmission, storage and display systems.

In order to optimise the characteristics of the system in terms of performance, handling capacity and cost, the relevant sub systems can be combined together. Analog Data Acquisition System is generally acquired and converted into digital form for the purpose of processing, transmission, display and storage.

Processing may consist of a large variety of operations, ranging from simple comparison to complicated mathematical manipulations. It can be for such purposes as collecting information (averages, statistics), converting the data into a useful form (e.g., calculations of efficiency of motor speed, torque and power input developed), using data for controlling a process, performing repeated calculations to separate signals buried in the noise, generating information for display, and various other purposes.

Data may be transmitted over long distances (from one point to another) or short distances (from test centre to a nearby PC).

The data may be displayed on a digital panel or on a CRT. The same be stored temporarily (for immediate use) or permanently for ready reference later.

Data acquisition generally relates to the process of collecting the input data in digital form as rapidly, accurately, and economically as necessary. The basic instrumentation used may be a DPM with digital outputs, a shaft digitiser, or a sophisticated high speed resolution device.

To match the input requirements with the output of the sensor, some form of scaling and offsetting is necessary, and this is achieved by the use of amplifier/attenuators.

For converting analog information from more than one source, either additional transducers or multiplexers are employed. To increase the speed with which information is accurately converted, sample-hold circuits are used. (In some cases, for analog signals with extra-wide range, logarithmic conversion is used.)

#### **Data Acquisition System Block Diagram:**

A schematic block diagram of a General Data Acquisition System (DAS) is shown in Fig. 17.1.

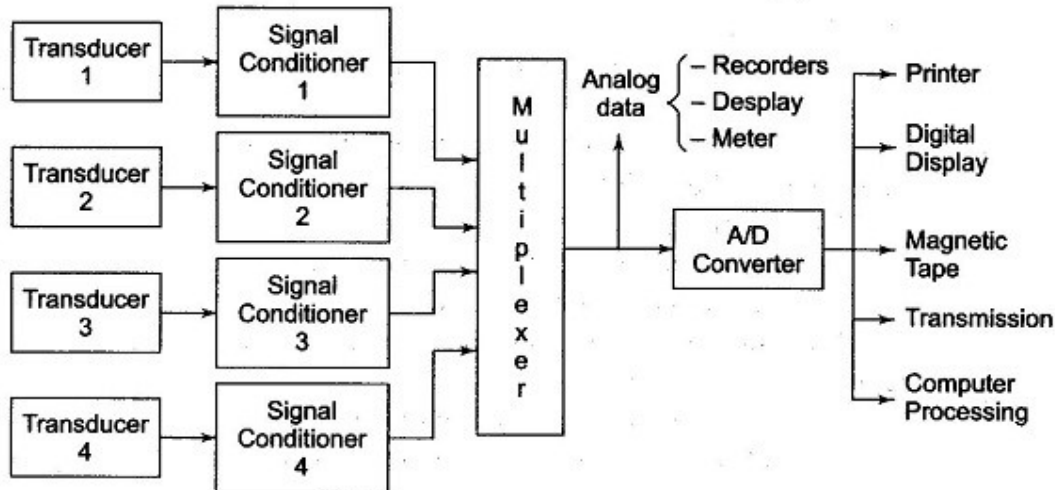

**Fig. 17.1** Generalised Data Acquisition System

The characteristics of the data acquisition system, depend on both the properties of the analog data and on the processing carried out.

Based on the environment, a broad Classifications of data acquisition system into two categories.

1. Those suitable for favourable environments (minimum RF interference and electromagnetic induction)
2. Those intended for hostile environments

The former category may include, among other, laboratory instrument applications, test systems for collecting long term drift information on zeners, high calibration test instruments, and routine measurements in research, as mass spectrometers and lock-in amplifiers. In these, the systems are designed to perform tasks oriented more towards making sensitive measurements than to problems of protecting the integrity of analog data.

The Classifications of data acquisition system specifically includes measure, protecting the integrity of the analog data under hostile conditions. Such measurement conditions arise in aircraft control systems, turbobus in electrical power systems, and in industrial process control systems.

Most of these hostile measurement conditions require devices capable of a wide range of temperature operations, excellent shielding, redundant paths for critical measurements and considerable processing of the digital data acquisition system.

On the other hand, laboratory measurements are performed over a narrow temperature range with much less electrical noise, employing high sensitivity and precision devices for higher accuracies and resolution.

The important Factors to Consider When Setting Up a Data Acquisition System are as follows.

1. **Accuracy and resolution**
2. **Number of channels to be monitored**
3. **Analog or digital signal**
4. **Single channel or multichannel**
5. **Sampling rate per channel**
6. **Signal conditioning requirements of each channel**
7. **Cost**

The various general Configuration of Data Acquisition System are

1. **Single channel possibilities**
  - Direct conversion
  - Pre-amplification and direct conversion
  - Sample and hold, and conversion
  - Pre-amplification, signal conditioning and any of the above
2. **Multi channel possibilities**
  - Multiplexing the outputs of single channel converters
  - Multiplexing the output of sample-hold circuits
  - Multiplexing the inputs of sample-hold circuits
  - Multiplexing low level data

#### **Objectives of Data Acquisition System:**

- It must acquire the necessary data, at correct speed and at the correct
- Use of all data efficiently to inform the operator about the state of the
- It must monitor the complete plant operation to maintain on-line optimum and safe operations.
- It must provide an effective human communication system and be able to identify problem areas, thereby minimising unit availability and maximising unit through point at minimum cost.
- It must be able to collect, summarise and store data for diagnosis of operation and record purpose.
- It must be able to compute unit performance indices using on-line, real-time data.
- It must be flexible and capable of being expanded for future require
- It must be reliable, and not have a down time greater than 0.1%.

#### **Single Channel Data Acquisition System:**

A Single Channel Data Acquisition System consists of a signal conditioner followed by an analog to digital (A/D) converter, performing repetitive conversions at a free running, internally determined rate. The outputs are in digital code words including over range indication, polarity information and a status output to indicate when the output digits are valid.

A Single Channel Data Acquisition System is shown in Fig. 17.3. The digital outputs are further fed to a storage or printout device, or to a digital computer

device, or to a [digital computer](#) for analysis. The popular Digital panel Meter (DPM) is a well known example of this. However, there are two major drawbacks in using it as a DAS.

1. It is slow and the BCD has to be changed into [binary coding](#), if the output is to be processed by digital equipment.
2. While it is free running, the data from the A/D converter is transferred to the interface register at a rate determined by the DPM itself, rather than commands beginning from the external interface.

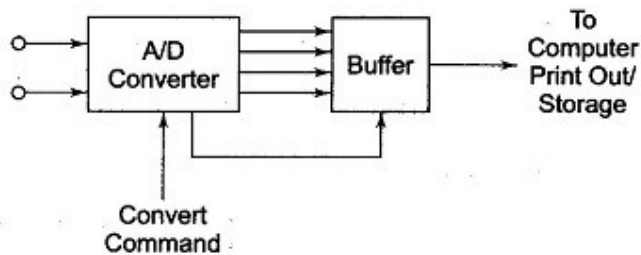

**Fig. 17.3** Single Channel DAS

#### Analog to Digital Converters (A/D):

Analog to digital converters used for DAS applications are usually designed to receive external commands to convert and hold. For dc and low frequency signals, a dual slope type converter is often used. The advantage is that it has a linear averaging capability and has a null response for frequencies harmonically related to the integrating period.

(Generally, the integrating time is selected equal to the period of the line frequency, since a major portion of the system interference occurs at this frequency and its harmonics.)

A/D converters based on dual slope techniques are useful for conversion of low frequency data, such as from thermocouples, especially in the presence of noise. The most popular type of converter for data system applications is the [successive approximation](#) type, since it is capable of high resolution and high speed at moderate cost. (For a conversion time of 10  $\mu$ S, the maximum dv/dt for full scale and 0.1% resolution is about 1 V/ms, which is a considerable improvement.)

Higher speeds are obtained by preceding the A/D converter by a sample hold (S/H). The sample hold is particularly required with successive approximation type A/D converters, since at higher rates of input change the latter generates substantial non-linearity errors because it cannot tolerate changes during the conversion process.

Direct [digital conversion](#) carried out near the signal source is very advantageous in cases where data needs to be transmitted through a noisy environment. Even with a high level signal of 10 V, an 8 bit converter (1/256 resolution) can produce 1 bit ambiguity when affected by noise of the order of 40 mV.

### Pre-amplification and Filtering:

Many low resolution (8/10 bit) A/D converters are constructed with a single ended input and have a normalised analog input range of the order of 5-10 V, bipolar or unipolar. For signal levels which are low compared to input requirements, amplification may be used in order to bring up the level of the input to match converter input requirements, so that optimum use can be made in terms of accuracy and resolution. The amplifier used has a single ended input or a differential input, as shown in Fig. 17.4.

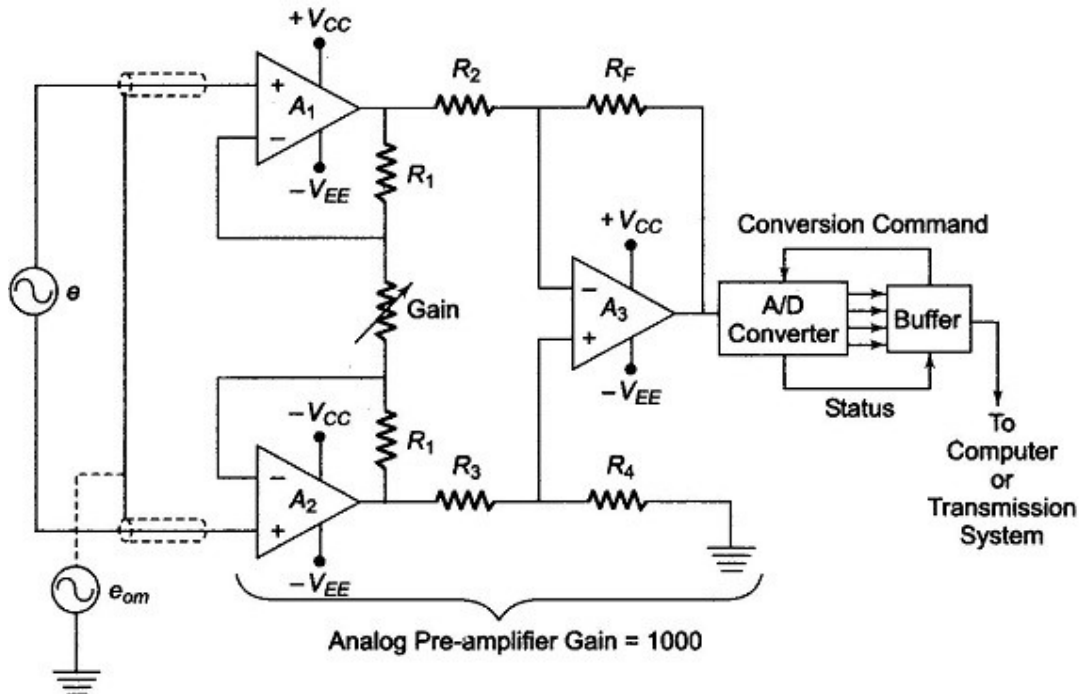

Fig. 17.4 DAS with Pre-amplification

If the signal levels are below a tenth of an mV, or when resolution of 14 bits or 16 bits is needed, the use of differential amplifiers can become a necessity. When differential output has to be handled from a bridge network, instrumentation amplifiers are employed.

The accuracy, linearity and gain stability specifications should be carefully considered, to ensure the system is not affected by any limitations.

If the input signals are to be physically isolated from the system, the conductive paths are broken by using a transformer coupled or an optocoupled isolation amplifier. These techniques are advantageous in handling signals from high voltage sources and transmission towers. In biomedical applications such isolation becomes essential.

Pre-amplifiers can be coupled with active filters before processing of data, in order to minimise the effect of noise carriers and interfering high frequency components. They effectively compensate for transmission sensitivity loss at

high frequency and hence enable measurements over an enhanced dynamic frequency range.

Special purpose filters, such as tracking filters, are used for preserving phase dependent data.

## Multi Channel Data Acquisition System:

The Multi Channel Data Acquisition System can be time shared by two or more input sources. Depending on the desired properties of the multiplexed system, a number of techniques are employed for such time shared measurements.

### Multi-Channel Analog Multiplexed System:

The multi-channel DAS has a single A/D converter preceded by a multiplexer, as shown in Fig. 17.5.

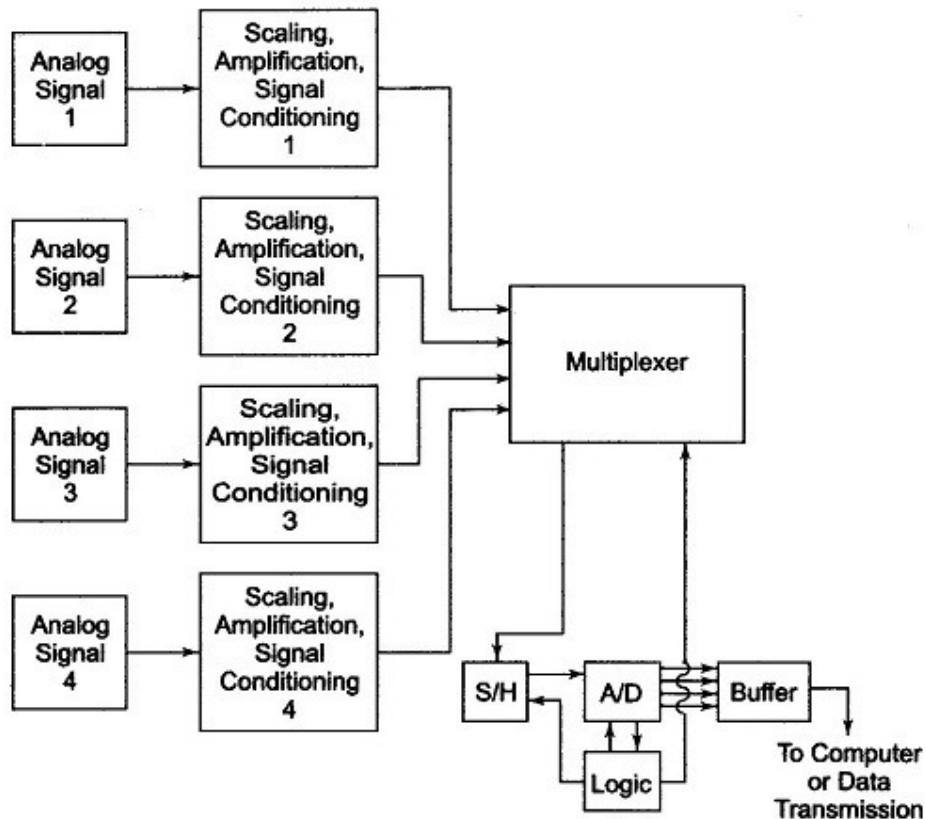

**Fig. 17.5** Multi-channel DAS (A/D Preceded by a Multiplexer)

The individual analog signals are applied directly or after amplification and/or signal conditioning, whenever necessary, to the multiplexer. These are further converted to digital signals by the use of A/D converters, sequentially.

For the most efficient utilisation of time, the multiplexer is made to seek the next channel to be converted while the previous data stored in the sample/hold is converted to digital form.



When the conversion is complete, the status line from the converter causes the sample/hold to return to the sample mode and acquires the signal of the next channel. On completion of acquisition, either immediately or upon command, the S/H is switched to the hold mode, a conversion begins again and the multiplexer selects the next channel. This method is relatively slower than systems where S/H outputs or even A/D converter outputs are multiplexed, but it has the obvious advantage of low cost due to sharing of a majority of sub-systems.

Sufficient accuracy in measurements can be achieved even without the S/H, in cases where signal variations are extremely slow.

#### Multiplexing the Outputs of Sample/Hold:

When a large number of channels are to be monitored at the same time (synchronously) but at moderate speeds, the technique of multiplexing the outputs of the S/H is particularly attractive.

An individual S/H is assigned to each channel as shown in Fig. 17.6, and they are updated synchronously by a timing circuit.

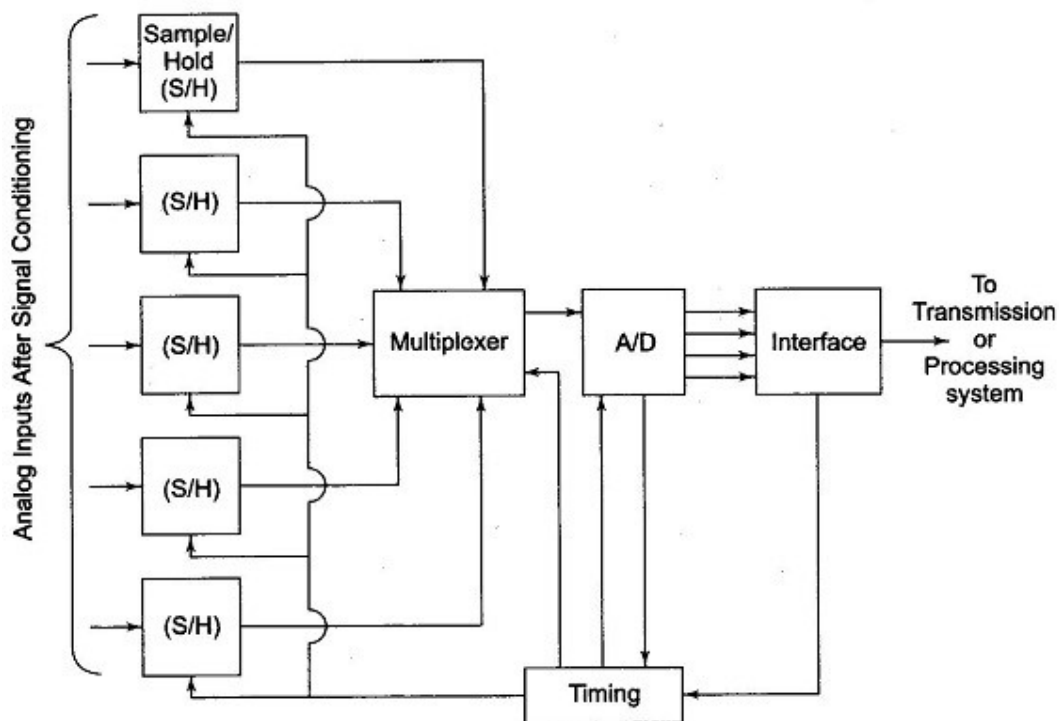

**Fig. 17.6** Simultaneous Sampled System Multiplexer

The S/H outputs are connected to an A/D converter through a multiplexer, resulting in a sequential readout of the outputs.

(Applications that might require this approach include wind tunnel measurements, seismographic experimentation, radar and fire control systems. The event to be measured is often a one-shot phenomenon and information is required at a critical point during a one-shot event.)

### Multiplexing After A/D Conversion:

It is now economically feasible to employ an A/D converter for each analog input and multiplex the digital outputs.

Since each analog to digital converter (A/D) is assigned to an individual channel, the conversion rate of the A/D need only be as fast as is needed for that channel, compared to the higher rates that would be needed if it were used as in a multi channel analog multiplexed system.

The parallel conversion scheme shown in Fig. 17.7 provides additional advantages in industrial data acquisition systems where many strain gauges, thermocouples and LVDTs are distributed over large plant areas. Since the analog signals are digitised at the source, the digital transmission of the data to the data centre (from where it can go on to a communication channel) can provide enhanced immunity against line frequency and other ground loop interferences. The data converted to digital form is used to perform logic operations and decisions. Based on the relative speed at which changes occur in the data, the scanning rate can be increased or decreased.

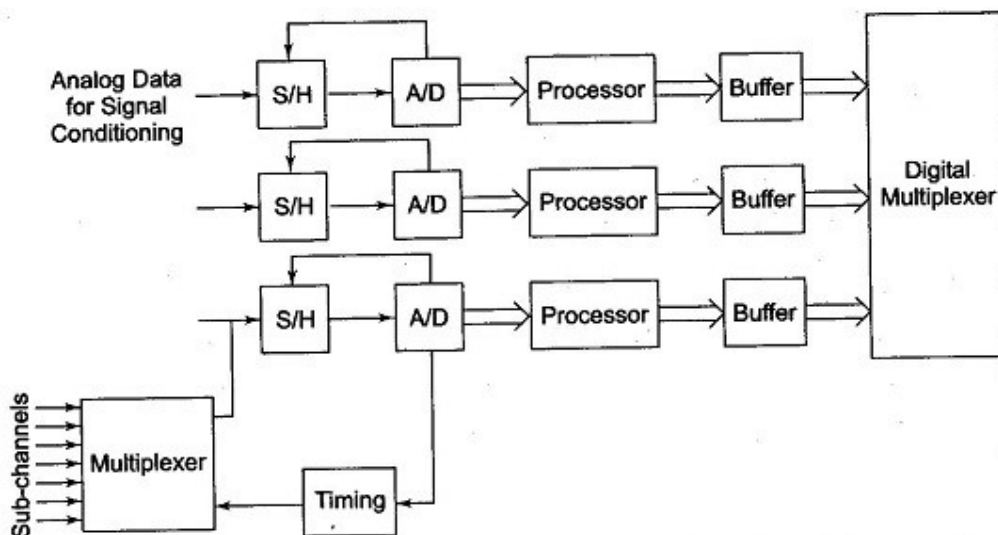

**Fig. 17.7** Multi-channel DAS Using Digital Multiplexing

Alternatively, input channels having slowly varying data can be pre-multiplexed in any of the forms suggested earlier, so that a set of sequentially multiplexed sub channels can then replace one channel of the main digital multiplexed system, as indicated in Fig. 17.7.

### Multiplexing Low Level Data:

A low level data multiplexing system, as shown in Fig. 17.8, enables the use of a single high quality data amplifier for handling multichannel low level inputs.



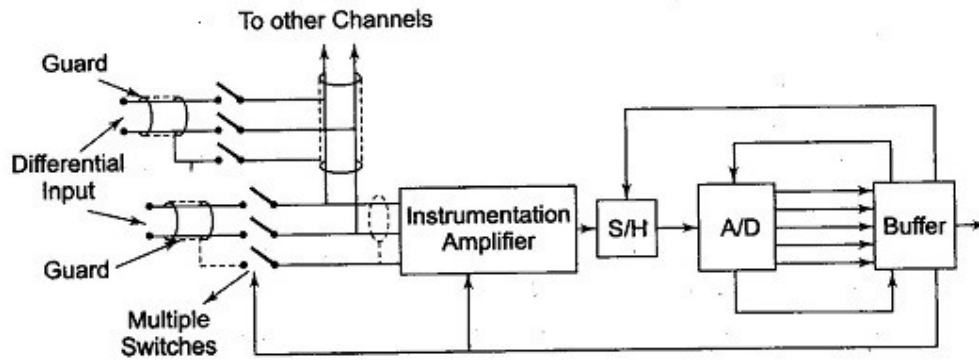

**Fig. 17.8** Low Level Multiplexing

Individual amplifiers are used for each low level signal. Low level multiplexing can be attractive when a large number of channels (25), all having low level outputs, need to be used at moderate speeds. The use of individual channels is possible because of the availability of high quality [amplifiers](#) at moderate cost. (A typical application is a 200 channel stress measurement system in a transmission tower set up.)

Several factors have to be considered to accomplish low level multiplexing successfully. Guarding may have to be employed for every channel, and each individual guard may have to be switched, so that the appropriate guard is driven by the common mode pertaining to that channel.

Problems of pickup gets more complicated and have to be taken care of, to preempt the possibility of signal-to-signal, and even common mode-to-differential mode signal cross-talk.

[Capacitance](#) balance may need to be carried out. When the number of channels to be multiplexed increases, the problems of stray capacitances and capacitive balance are worsened.

In the specific case of a 48 channel system, the input channels are subdivided into groups of eight channels in the first tier. Each of these six subgroups are in turn multiplexed by a six channel [multiplexer](#) on the second tier. The main advantage of using this is the reduction of capacitance effects.

## Computer Based Data Acquisition System:

Computer Based Data Acquisition System – If a large number of inputs are to be measured, some equipment is needed to measure them and display the results in a meaningful and operationally useful fashion. All this is possible with Data Acquisition System, which utilises a [computer](#) driven visual display unit (CRT) as an operator aid.

A screen display can be obtained within two seconds by pressing a button. Information may be displayed only when called up. The screen display can be designed in several ways, using a combination of graphical and numeric displays, so as to be of maximum utility to the operator.

Data Acquisition System aids operate in the following manner.

- Display information instantly in condensed, understandable and legible manner so that it can be easily assimilated.
- Display spatial as well as time variation.
- Display vital **parameters** grouped together logically and concisely, eliminating the need of looking at many scattered instruments.
- Display **CRT** graphic displays of plant sub-systems.
- Display short trends on a long and short term basis, as required.
- Analyse the data and present the highest priority problem first, and display operator guidance messages.
- Analyse the data and present the derived data; do performance calculations to depict the performance of several equipments and plants.
- Display **alarms**, indicating abnormal plant operating conditions on the
- Provide trending of **analog variables** on strip chart recorders, in the form of a histogram on the CRT, and provide dynamic updating of parameters.
- Produce a hard copy record of all plant operating events and various **plant**
- Provide a recording of the sequence of events, whenever an emergency occurs.

## Compact Data Logger:

Compact Data Logger – A typical unit provides 60 channels of data in a 20 x 40 x 60 cm box weighing about 20 kg. Most manufacturers offer local or remote add-on scanners to expand to about 1000 channels. Scan rates are modest usually (1 — 20 channels per second) and though versatile signal conditioning is provided, the signal processing capability is limited to simple functions such as  $(mx + b)$  scaling, time averaging of single channels, group averaging of several channels, and **alarm** signaling when preset limits are exceeded. However, most units do allow interfacing to computers, where versatile processing is possible.

Compact Data Logger of this class utilise a built in microprocessor to control the interval of operations and carry out calculations through a single amplifier — A/D converter, which is automatically ranged or gain switched under program control to accommodate the **signal level** of each channel, as shown in Fig. 17.26.

This is not useful for applications in which fast changing signals must be observed, since a (typical) 5 channels per second scan rate takes 12 s to scan 60 channels before returning to any given channel. Also, the time skew of 12 s can cause a density error if the signals change too rapidly (for example, if gas

density from a pressure on channel 1 and temperature on channel 60 is measured).

Often multiplexers ([scanners](#)) are available in both general purpose (two wire) and low level (two original wires plus shield) versions, since milli-volt level signals, such as from thermocouples, generally use a shielded, twisted pair of conductors. A three wire system scanner can reduce errors from about 10 to 1  $\mu\text{V}$ . Electro-mechanical reed switches are used frequently in such scanners, since speed requirements are modest but low noise is important.

Since [thermocouples](#) are very common in Compact Data Logger applications, reference junction compensation and linearization options are always available. Reference-junction compensation can be offered economically and accurately for any mixture of thermocouple types by the use of an isothermal connection block. This thermocouple terminal block is designed to have an uniform ( $\pm 0.05^\circ\text{C}$ ) temperature (the reference junction) over its length. The block temperature is allowed to drift with ambient conditions, but is measured (often with a junction semiconductor sensor, since these work well near room temperature). This reference-junction temperature is sent to the microprocessor, where the temperature/voltage data for each thermocouple being employed is stored and the necessary correction is calculated. The [microprocessor](#) also stores the equations which curve-fit the thermocouple tables (over the desired range) for each thermocouple type, providing software linearization. For resistance thermometers the Compact Data Logger provide constant-current excitation and software linearizations.

The system [amplifier](#) and A/D converter are the crucial elements for overall system accuracy. Since Compact Data Logger inputs vary widely in voltage range, while the A/D input is typically fixed at +10 V, the microprocessor sets the amplifier gain at a proper value as each channel is sampled (some Compact Data Logger also provides automatic ranging). These range selections are entered from the front panel when the logger is programmed for the particular application. Programming of this and other functions is very simple, and do not

require a knowledge of computer languages.

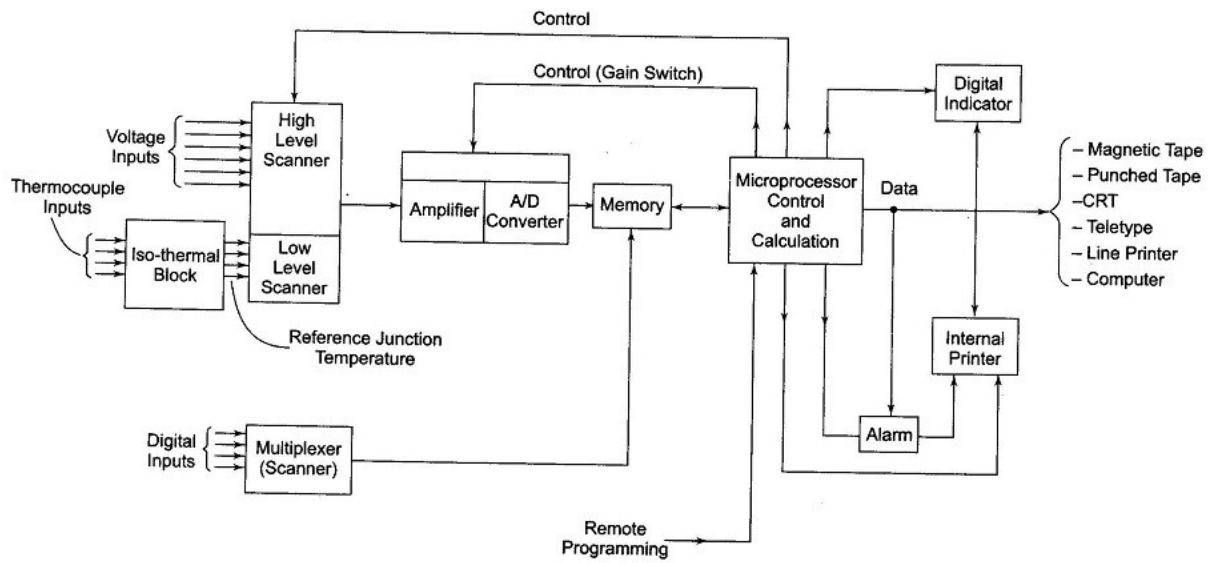

Fig. 17.26 Compact Data Logger Configuration

A typical set of ranges and resolutions would be  $\pm 40$  mV ( $1 \mu\text{V}$  resolution),  $\pm 400$  mV ( $10 \mu\text{V}$  resolution),  $\pm 4$  V ( $100 \mu\text{V}$ ) and  $\pm 40$  V ( $1$  mV) with a input impedance of  $200 \text{ M}\Omega$ . (Except  $10 \text{ M}\Omega$  on  $40$  V range). Zero drift is kept negligible by an automatic zero system.

A/D converters are often of the dual slope type or voltage to frequency type, since conversion speed is modest and these integrating converters give good noise rejection. Fast or slow scanning rates (say 15 versus 3 channels per second) may be selected, to allow a trade off between speed and accuracy, since as integration time is increased the integrating A/D noise rejection improves.

A readout obtained by means of a built in digital indicator and two colour printer (prints alarm in red), or channel number, date and time of day is a standard. When a built-in printer is used, the printer speed (2 to 4 channels per second) limits the overall speed, even though scanning without printing may be possible at 15 to 20 channels per second. The readout format is selected by front panel programming.

Some units provide a 5 years non-volatile program memory which preserves stored programs in case of power failure. Interface options for external [magnetic tape](#), punched tape, [CRT](#) terminals, line printers and computers are usually obtainable.

## Sensors Based Computer Data Systems:

This Sensors Based Computer Data Systems describes hardware/software which is commercially available at several levels of completeness, ranging from single board computer “front ends” to stand alone system and high level programming languages.

Even the simplest and least expensive devices require considerable electronics/computer expertise on the part of the user, access to a micro-computer development system and sufficient engineering time to integrate the interface and computer into a working overall system. Since micro-computer system design is specialised and beyond the range of this text, we give only a brief description of micro-computer interface boards, shown in Fig. 17.27 as an example. These are available from several manufacturers, and interfaced with most popular micro-computers.

To reduce program storage requirements and execution times (at the expense of memory address area), a memory mapped I/O is often employed. Note that analog inputs (up to 32 single ended inputs 16 differential inputs) are processed through a multiplexer, programmable gain amplifier (PGA), sample/hold (S/H), and A/D converter in a fashion very similar to that of a data logger.

However, since we wish to handle HF signals, a successive approximations (rather than dual-slope) A/D converter (maximum throughput rate 28 kHz) and an electronic (rather than reed switch) multiplexer are necessary.

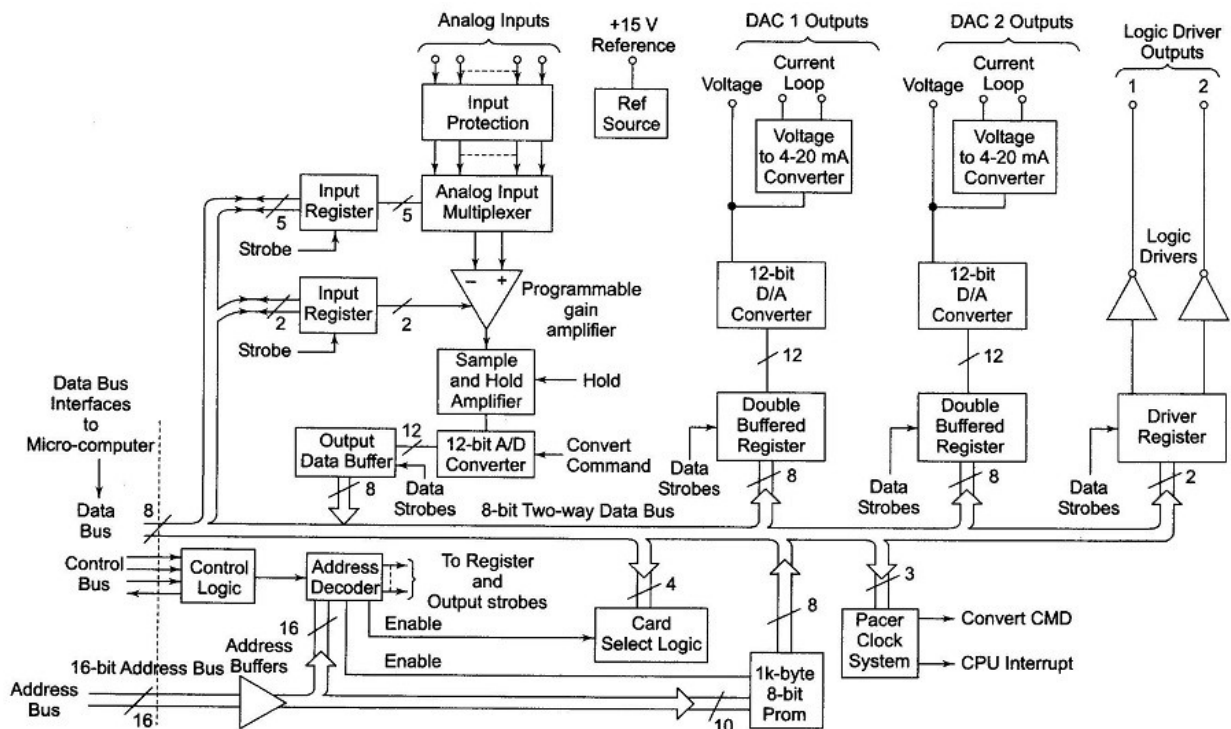
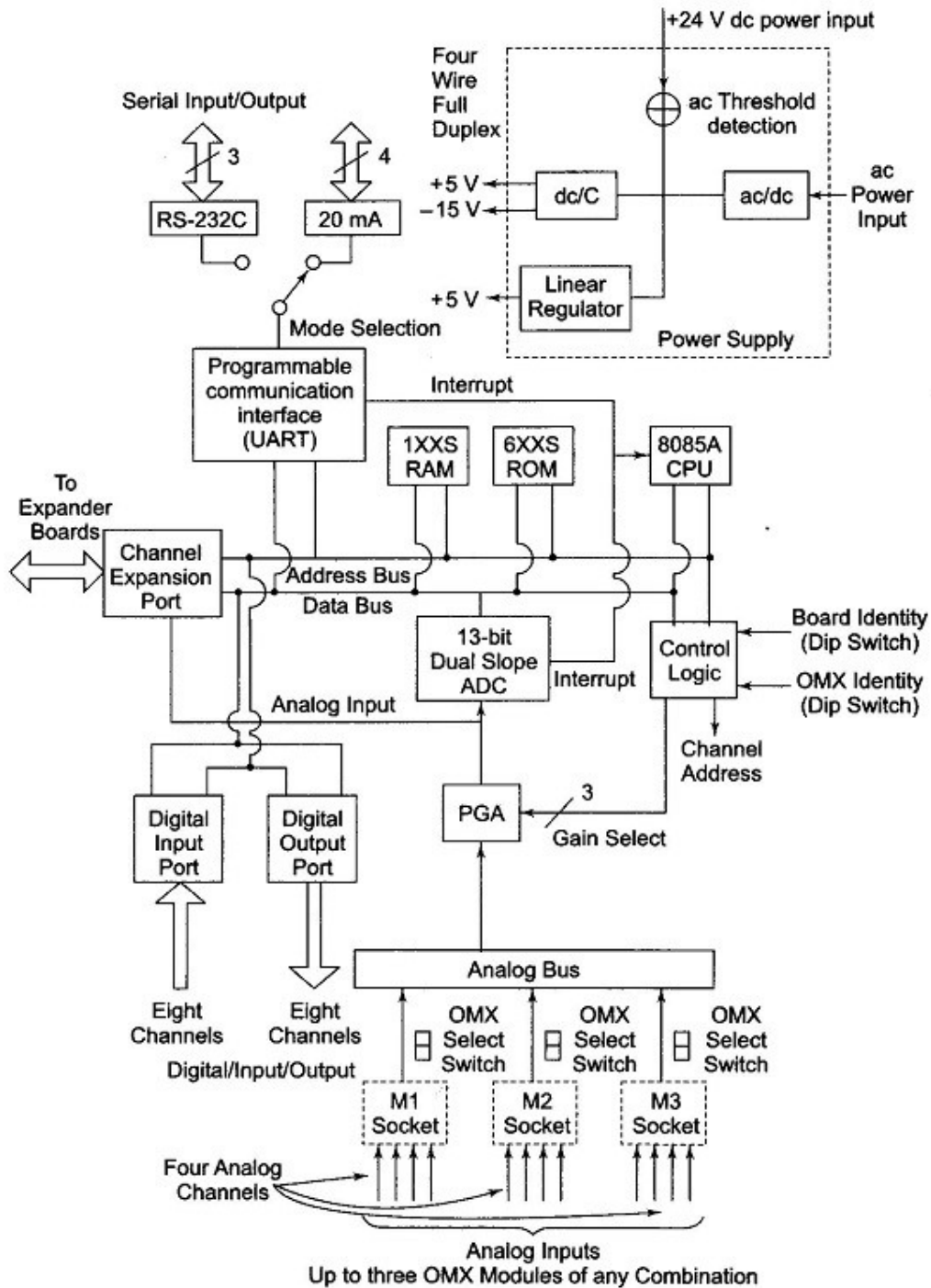

Fig. 17.27 Micro-computer Interface Board

It is possible to obtain two (optional) D/A converters for driving analog recorders, generating analog control signals, etc. The hardware problems are reduced to a minimum by the use of such an interface card. Also, the overall system throughput rate must be less (often much less) than the 28 kHz value given

above, since software execution time must be added to the A/D conversion



**Fig. 17.28** Micro-computer Based Data Acquisition System

time.

Figure 17.28 shows a single board, micro-computer based data acquisition system designed to accept multichannel analog and digital inputs and provide digital output to a host computer (usually a mini-frame or Main frame supporting high level languages such as BASIC and FORTRAN) through a standard serial



communications port (RS 232C or 20 mA current loop). The on-board micro-computer unburdens the host computer by allowing supervisory control.

It performs data acquisition control, linearization, conversion to engineering units, limits checking, interface control, and data output formatting. The analog channels are scanned continuously (15 to 30 channels per second) and the resultant data are stored in the micro-computer memory (RAM). The data in the RAM is refreshed on a continuous basis (the latest data is kept in memory), so that requests for data from the host are serviced immediately. Upon receipt of a transit command, the micro-computer [via. the UART (Universal Asynchronous Receiver Transmitter)] begins transmitting a string of data in the ASCII format to the host. No programming of the micro-computer is necessary, since it is preprogrammed by the firmware to respond to host commands.

The 12 channels of the analog input are broken into 3 groups of 4, and convenient 4 channel plug-in modules for thermocouples, RTDs, strain gauge transducers, etc. are available. Up to three expander boards can be controlled by a master board, creating a cluster as shown in Fig. 17.29. Up to 8 clusters can be operated from the same host, providing expansion to 384 channels.

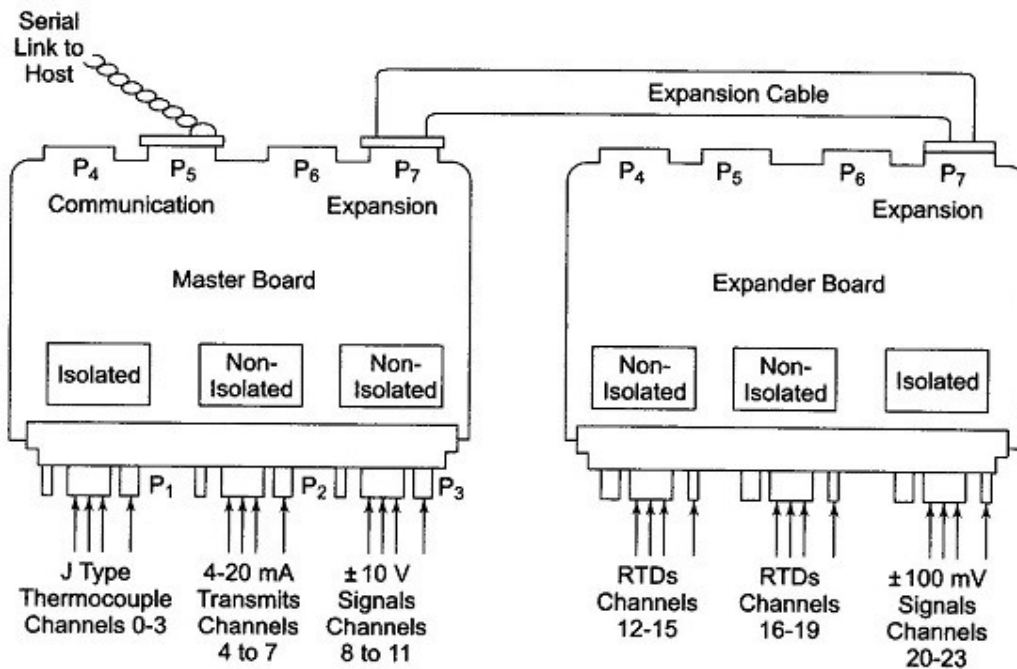

**Fig. 17.29** System Expansion by Clustering

For those applications in which a sensor based measurement and control system with comprehensive and easy to use computer processing is designed, with a minimum of user engineering effort, complete stand alone systems such as that of Fig. 17.30 are available.

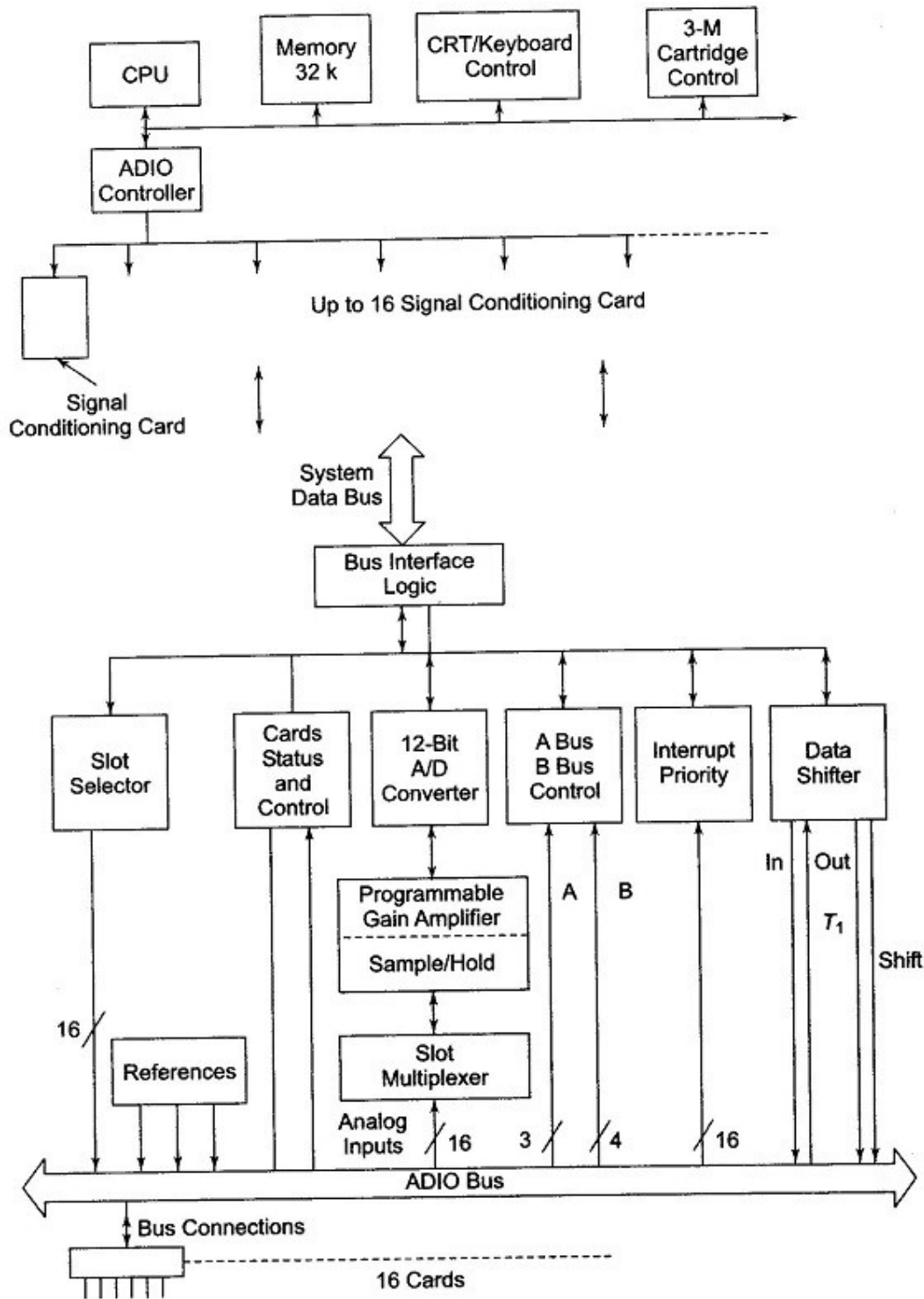

**Fig. 17.30** Minicomputer Based DAS

Analog and digital input/output is through a plug-in signal conditioning cards, space for 16 cards is provided (expandable up to 256 cards). A wide selection of cards functions are available, allowing easy interfacing with all kinds of sensors and control devices. Single cards are often themselves multichannel

devices with a multiplexer on the card. Thus, two level of computer controlled multiplexing are present, slot multiplexing (chooses the card slot desired) and card channel multiplexing (selects the channel wanted on the chosen card).

For example, a single digital input card provides 16 channels (bits) while the analog input card has 32 channels (single ended) or 16 channels (differential). This analog card has its own PGA (gain = 1, 16, 256) which combined with the PGA of the central controller (gain = 1, 2, 4, 8), allows versatile selection of channel gain under program control. Thermocouple cards are four channel units, which share a common reference-junction compensation circuit and have fixed gain. Linearization is accomplished in software by a general purpose polynomial sub-routine. A fast (25  $\mu$ S conversion time) successive approximation A/D converter allows rapid scanning and storage of analog input (mixed channels at 2 kHz, single channel at 4 kHz). A mini computer specially designed for measurement control applications has 32,000 words of 16 bit MOS random access memory (RAM) augmented by 105 k bytes of cartridge tape mass storage.

Programming is a Macbasic (a version of BASIC) specially enhanced for easy system operation. For example, the statement

$$V = \text{AIN}(2,1) - 1.53$$

assigns to the variable V, the value of the analog voltage on channel 1 of the analog input card in the I/O slot 2, minus 1.53. Similarly, the statement

$$\text{AOT}(1,3) = 3.42 * 1.3$$

places a voltage of 4.44 V on Channel 3 of the analog output card in I/O slot 1. For digital input variable DIN

$$I' = \text{DIN}(3,1)$$

takes the digital logic level from Channel 1 of the digital input card in I/O slot 3 and places it in I', where I' is an integer variable.

For digital output variable DOT  $\text{DOT}(8,3) = X$

turns on Channel 3 of the digital output card in I/O slot 8 if X = 1 and turns it off if X = 0.

System timing functions are eased by the availability of statements such as

**WAIT 5.6**

which causes the program to wait 5.6 before proceeding to the next statement.

A common requirement of many applications is the ability to perform several operations or tasks independently of one another in the same program. Examples include the monitoring of several analog signals in the laboratory or control of several process loops. To provide for this requirement, Macbasic is

structured as a multitasking language and contains the necessary words for implementation.

Tasks are groups of Macbasic language statements that are defined as a task, and are executed each time the task is activated unconditionally or by satisfaction of a condition (such as an external event), or on a periodic basis. Up to 18 tasks may be defined at a given time and if more than one task is active at a given moment, the active task share resources and run simultaneously, unless priority is assigned to a particular task. If a task completes its operation, it can DISMISS itself and return its resources to the system until the task is reactivated.